

YASKAWA

iQpump1000 AC Drive Intelligent Pump Controller Installation & Start-Up Guide

Type: CIMR-PW□A□□

Models: 200 V Class: 3/4 to 175 HP ND
400 V Class: 3/4 to 1000 HP ND
600 V Class: 2 to 250 HP ND

To properly use the product, read this manual thoroughly and retain for easy reference, inspection, and maintenance. Ensure the end user receives this manual.

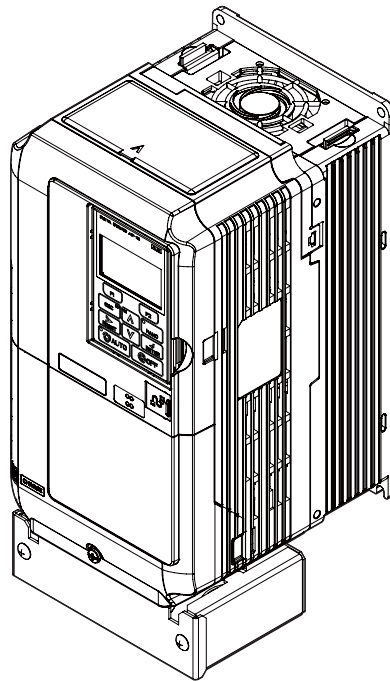

iQPUMP[®]1000

Intelligent Pump Controller

MANUAL NO. TOEYAI1W02F
PUBLISHED OCTOBER 2022
REVISION <6>
DRIVE SOFTWARE PRG: 8556

This Page Intentionally Blank

Copyright © 2013 YASKAWA AMERICA, INC. All rights reserved.

No part of this publication may be reproduced, stored in a retrieval system, or transmitted, in any form or by any means, mechanical, electronic, photocopying, recording, or otherwise, without the prior written permission of Yaskawa. No patent liability is assumed with respect to the use of the information contained herein. Moreover, because Yaskawa is constantly striving to improve its high-quality products, the information contained in this manual is subject to change without notice. Every precaution has been taken in the preparation of this manual. Yaskawa assumes no responsibility for errors or omissions. Neither is any liability assumed for damages resulting from the use of the information contained in this publication.

iQpump1000 Installation & Start-up Guide

i.1	PREFACE.....	4
i.2	RECEIVING.....	11
i.3	MECHANICAL INSTALLATION.....	14
i.4	ELECTRICAL INSTALLATION.....	19
i.5	START-UP PROGRAMMING AND OPERATION.....	44
i.6	TROUBLESHOOTING.....	74
i.7	DRIVE SPECIFICATIONS.....	85
i.8	PARAMETER TABLE.....	87
i.9	STANDARDS COMPLIANCE.....	98

i.1 Preface

Yaskawa manufactures products used as components in a wide variety of industrial systems and equipment. The selection and application of Yaskawa products remain the responsibility of the equipment manufacturer or end user. Yaskawa accepts no responsibility for the way its products are incorporated into the final system design. Under no circumstances should any Yaskawa product be incorporated into any product or design as the exclusive or sole safety control. Without exception, all controls should be designed to detect faults dynamically and fail safely under all circumstances. All systems or equipment designed to incorporate a product manufactured by Yaskawa must be supplied to the end user with appropriate warnings and instructions as to the safe use and operation of that part. Any warnings provided by Yaskawa must be promptly provided to the end user. Yaskawa offers an express warranty only as to the quality of its products in conforming to standards and specifications published in the Yaskawa manual. **NO OTHER WARRANTY, EXPRESS OR IMPLIED, IS OFFERED.** Yaskawa assumes no liability for any personal injury, property damage, losses, or claims arising from misapplication of its products.

This manual is designed to ensure correct and suitable application of drives. Read this manual before attempting to install, operate, maintain, or inspect a drive and keep it in a safe, convenient location for future reference. Be sure you understand all precautions and safety information before attempting application.

◆ Applicable Documentation

The following manuals are available for iQpump1000 drives:

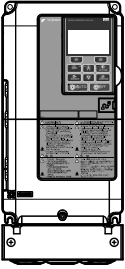
	<p>iQpump1000 AC Drive Installation & Start-up Guide (TOEPYAIP1W02)</p> <p>Read this guide first. This guide is packaged together with the product and contains basic safety information, wiring information, and a list of models. Use this manual for basic settings and trial operation. The most recent version of this manual is available for download on our documentation website, www.yaskawa.com.</p>
	<p>iQpump1000 AC Drive User Manual (TOEPYAIP1W01)</p> <p>This manual contains information required to install and wire the drive, and gives an overview of fault diagnostics, maintenance safety, and parameter settings. The most recent version of this manual is available for download on our documentation website, www.yaskawa.com. Contact a Yaskawa representative to obtain a printed and bound version of the manual.</p>
	<p>iQpump1000 Simplex Quick Start Procedure (TM.iQp1000.01)</p> <p>This sheet is packaged together with the drive and contains a step-by-step guide to enable the user to properly wire the drive and motor. It also describes simplex pump application configuration.</p>

◆ Supplemental Safety Information

General Precautions

- The diagrams in this manual may be indicated without covers or safety shields to show details. Replace the covers or shields before operating the drive and run the drive according to the instructions described in this manual.
- Any illustrations, photographs, or examples used in this manual are provided as examples only and may not apply to all products to which this manual is applicable.
- The products and specifications described in this manual or the content and presentation of the manual may be changed without notice to improve the product and/or the manual.
- When ordering a new copy of the manual due to damage or loss, contact Yaskawa or a Yaskawa representative and provide the manual number shown on the front cover.
- If nameplate becomes worn or damaged, order a replacement from Yaskawa or a Yaskawa representative.

⚠ WARNING

Read and understand this manual before installing, operating or servicing this drive. The drive must be installed according to this manual and local codes.

The following conventions are used to indicate safety messages in this manual. Failure to heed these messages could result in serious or fatal injury or damage to the products or to related equipment and systems.

⚠ DANGER

Indicates a hazardous situation, which, if not avoided, will result in death or serious injury.

⚠ WARNING

Indicates a hazardous situation, which, if not avoided, could result in death or serious injury.

WARNING! may also be indicated by a bold key word embedded in the text followed by an italicized safety message.

⚠ CAUTION

Indicates a hazardous situation, which, if not avoided, could result in minor or moderate injury.

CAUTION! may also be indicated by a bold key word embedded in the text followed by an italicized safety message.

NOTICE

Indicates a property damage message.

NOTICE: may also be indicated by a bold key word embedded in the text followed by an italicized safety message.

◆ Safety Messages**⚠ DANGER**

Heed the safety messages in this manual.

Failure to comply will result in death or serious injury.

The operating company is responsible for any injuries or equipment damage resulting from failure to heed the warnings in this manual.

Electrical Shock Hazard

Before servicing, disconnect all power to the equipment.

The internal capacitor remains charged even after the power supply is turned off. The charge indicator LED will extinguish when the DC bus voltage is below 50 Vdc. To prevent electric shock, wait for at least the time specified on the warning label, once all indicators are OFF, measure for unsafe voltages to confirm the drive is safe prior to servicing.

Failure to comply will result in death or serious injury.

⚠ WARNING**Sudden Movement Hazard**

System may start unexpectedly upon application of power, resulting in death or serious injury.

Clear all personnel from the drive, motor and machine area before applying power. Secure covers, couplings, shaft keys and machine loads before applying power to the drive.

Electrical Shock Hazard

Do not attempt to modify or alter the drive in any way not explained in this manual.

Failure to comply could result in death or serious injury.

Yaskawa is not responsible for any modification of the product made by the user. This product must not be modified.

Do not allow unqualified personnel to use equipment.

Failure to comply could result in death or serious injury.

Installation, maintenance, inspection, and service must be performed only by authorized personnel familiar with installation, adjustment and maintenance of AC drives.

⚠ WARNING

Do not remove covers or touch circuit boards while the power is on.

Failure to comply could result in death or serious injury.

Make sure the protective earthing conductor complies with technical standards and local safety regulations.

Always use appropriate equipment for Ground Fault Circuit Interrupters (GFCIs).

The drive can cause a residual current with a DC component in the protective earthing conductor. Where a residual current operated protective or monitoring device is used for protection in case of direct or indirect contact, always use a type B GFCI according to IEC/EN 60755.

Fire Hazard

Do not use an improper voltage source.

Failure to comply could result in death or serious injury by fire.

Verify that the rated voltage of the drive matches the voltage of the incoming power supply before applying power.

Install adequate branch circuit protection according to applicable local codes and this Installation Manual. Failure to comply could result in fire and damage to the drive or injury to personnel.

The device is suitable for use on a circuit capable of delivering not more than 100,000 RMS symmetrical amperes, 240 Vac maximum (200 V class) and 480 Vac maximum (400 V class) when protected by branch circuit protection devices specified in this document.

Crush Hazard

Do not use this drive in lifting applications without installing external safety circuitry to prevent accidental dropping of the load.

The drive does not possess built-in load drop protection for lifting applications.

Failure to comply could result in death or serious injury from falling loads.

Install electrical and/or mechanical safety circuit mechanisms independent of drive circuitry.

⚠ CAUTION

Crush Hazard

Do not carry the drive by the front cover.

Failure to comply may result in minor or moderate injury from the main body of the drive falling.

NOTICE

Observe proper electrostatic discharge procedures (ESD) when handling the drive and circuit boards. Failure to comply may result in ESD damage to the drive circuitry.

Do not perform a withstand voltage test or megger test on any part of the drive.

Failure to comply could result in damage to the sensitive devices within the drive.

Do not operate damaged equipment.

Failure to comply could result in further damage to the equipment. Do not connect or operate any equipment with visible damage or missing parts.

If a fuse is blown or a Ground Fault Circuit Interrupter (GFCI) is tripped, check the wiring and the selection of the peripheral devices.

Check for short circuits or ground faults on the secondary side of fuses and GFCIs and check the wiring and the selection of peripheral devices. Remove the cause of the problem and then turn the power supply off and on again. If the cause cannot be identified, do not turn on the power supply or attempt to operate the equipment.

Do not restart the drive immediately operate the peripheral devices if a fuse is blown or a GFCI is tripped.

Check the wiring and the selection of peripheral devices to identify the cause. Contact Yaskawa or a Yaskawa representative before restarting the drive or the peripheral devices if the cause cannot be identified.

Do not expose the drive to halogen group disinfectants.

Failure to comply may cause damage to the electrical components in the drive.

Do not pack the drive in wooden materials that have been fumigated or sterilized. Do not sterilize the entire package after the product is packed.

■ General Application Precautions

Selection

Installing a Reactor

Use an AC reactor or DC link choke in the following situations:

- to suppress harmonic current.
- to smooth peak current that results from capacitor switching.
- when the power supply is above 600 kVA.
- when the drive is running from a power supply system with thyristor converters.

Note: A DC link choke is built in to drive models 2A0110 to 2A0415, 4A0058 to 4A1200, and 5A0041 to 5A0242.

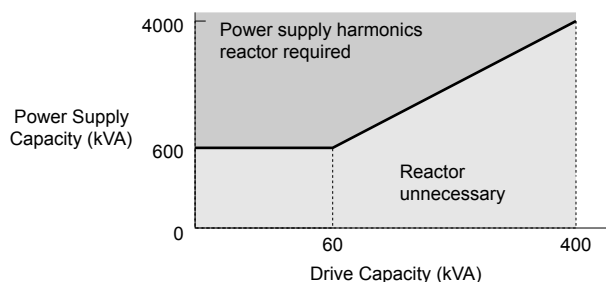

Figure i.1 Installing a Reactor

Drive Capacity

For specialized motors, make sure that the motor rated current is less than the rated output current for the drive.

When running more than one motor in parallel from a single drive, the capacity of the drive should be larger than [total motor rated current \times 1.1].

■ Installation

Enclosure Panels

Keep the drive in a clean environment by installing the drive in an enclosure panel or selecting an installation area free of airborne dust, lint, and oil mist. Be sure to leave the required space between drives to provide for cooling, and take proper measures so the ambient temperature remains within allowable limits and keep flammable materials away from the drive. Yaskawa offers protective designs for drives that must be used in areas subjected to oil mist and excessive vibration. Contact Yaskawa or a Yaskawa representative for details.

Installation Direction

NOTICE: *Install the drive upright as specified in the manual. Refer to [Mechanical Installation on page 14](#) for more information on installation. Failure to comply may damage the drive due to improper cooling.*

■ Settings

Upper Limits

NOTICE: *The drive is capable of running the motor up to 400 Hz. Be sure to set the upper limit for the frequency of the drive to prevent the possible danger of accidentally operating equipment at higher than rated speed. The default setting for the maximum output frequency is 60 Hz.*

Lower Limits

NOTICE: *Many pumps have a minimum safe operating speed. Be sure to properly set the minimum pump speed in to protect the pump from damage.*

DC Injection Braking

NOTICE: *Excessive current during DC Injection Braking and excessive duration of DC Injection Braking can cause motor overheat.*

Acceleration/Deceleration Times

Acceleration and deceleration times are affected by the amount of torque generated by the motor, the load torque, and the inertia moment. Set a longer accel/decel time when Stall Prevention is enabled. The accel/decel times are lengthened for as long as the Stall Prevention function is in operation.

■ General Handling

Wiring Check

NOTICE: *Do not connect power supply lines to output terminals U/T1, V/T2, or W/T3. Failure to comply will destroy the drive. Be sure to perform a final check of all sequence wiring and other connections before turning on the power and also check for short circuits on the control terminals, which may damage the drive.*

Selecting a Circuit Breaker or Circuit Interrupter

Yaskawa recommends installing a Ground Fault Circuit Interrupter (GFCI) to the power supply side. The GFCI should be designed for use with AC drives (e.g., Type B according to IEC 60755).

Select a Molded Case Circuit Breaker (MCCB) or GFCI with a rated current 1.5 to 2 times higher than the drive rated input current to avoid nuisance trips caused by harmonics in the drive input current.

Magnetic Contactor Installation

NOTICE: *To get the full performance life out of the electrolytic capacitors and circuit relays, refrain from switching the drive power supply off and on more than once every 30 minutes. Frequent use can damage the drive. Use the drive to stop and start the motor.*

Inspection and Maintenance

WARNING! Electrical Shock Hazard. *Capacitors in the drive do not immediately discharge after shutting off the power. Wait for at least the amount of time specified on the drive before touching any components after shutting off the power. Failure to comply may cause injury to personnel from electrical shock.*

WARNING! Burn Hazard. *Because the heatsink can get very hot during operation, take proper precautions to prevent burns. When replacing the cooling fan, shut off the power and wait at least 15 minutes to be sure that the heatsink has cooled down. Failure to comply may cause burn injury to personnel.*

Wiring

Yaskawa recommends using ring terminals on all drive models. Drive models 2A0069 to 2A0415, 4A0058 to 4A1200, and 5A0041 to 5A0242 require the use of use ring terminals for UL/cUL compliance. Use only the tools recommended by the terminal manufacturer for crimping.

Transporting the Drive

NOTICE: *Never steam clean the drive. During transport, keep the drive from coming into contact with salts, fluorine, bromine, phthalate ester, and other such harmful chemicals.*

◆ Motor Application Precautions

■ Standard Induction Motors

Insulation Tolerance

NOTICE: Consider motor voltage tolerance levels and motor insulation in applications with an input voltage of over 440 V or particularly long wiring distances.

High-Speed Operation

NOTICE: Problems may occur with the motor bearings and dynamic balance of the machine when operating a motor beyond its rated speed. Contact the motor or machine manufacturer.

Torque Characteristics

Torque characteristics differ compared to operating the motor directly from line power. The user should have a full understanding of the load torque characteristics for the application.

Vibration and Shock

The drive allows selection of high carrier PWM control and low carrier PWM. Selecting high carrier PWM can help reduce motor oscillation (drive current derating may be required).

Take particular caution when adding a variable speed drive to an application running a motor from line power at a constant speed. If resonance occurs, use shock absorbing mounts to the motor base and enable the Jump frequency selection to prevent continuous operation in the resonant frequency range.

Audible Noise

The audible noise of the motor varies based on the carrier frequency setting. However, drive current derating may be required. When using a high carrier frequency, audible noise from the motor is comparable to the motor noise generated when running from line power.

Specialized Motors

Submersible Motor

The rated current of a submersible motor is greater than that of a standard motor, so select the drive accordingly. Use a motor cable large enough to avoid decreasing the maximum torque level from voltage drop caused by a long motor cable.

Explosion-Proof Motor

The motor and the drive must be tested together to be certified as explosion-proof. The drive is not designed for explosion-proof areas.

Geared Motor

Make sure that the gear and the lubricant are rated for the desired speed range to avoid gear damage when operating at low speeds or very high speeds. Consult with the manufacturer for applications that require operation outside the rated speed range of the motor or gear box.

Single-Phase Motor

Variable speed drives are not designed to operate with single phase motors. Using capacitors to start the motor causes a high-frequency current to flow to the capacitors and can damage the capacitors. A split-phase start or a repulsion start can burn out the starter coils because the internal centrifugal switch is not activated. The drive is for use with three-phase motors only.

■ Notes on Power Transmission Machinery

Installing an AC drive in machinery that was previously connected directly to the power supply will allow the machine to operate at variable speeds. Continuous operation outside of the rated speeds can wear out lubrication material in gear boxes and other power transmission parts. Make sure that lubrication is sufficient within the entire speed range to avoid machine damage. Note that operation above the rated speed can increase the noise generated by the machine.

◆ Drive Label Warning Example

Always heed the warning information listed in *Figure i.2*.

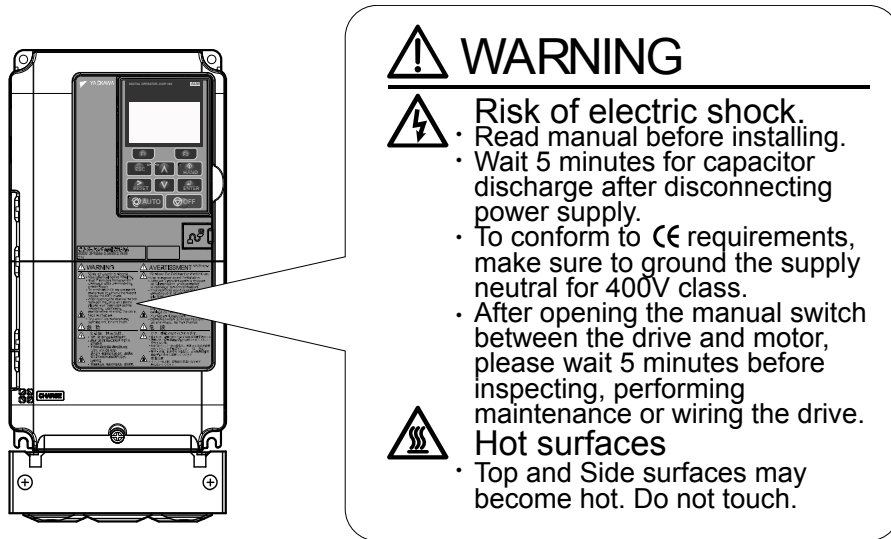

Figure i.2 Warning Information and Location

◆ Warranty Information

■ Restrictions

The drive is not designed or manufactured for use in devices or systems that may directly affect or threaten human lives or health.

Customers who intend to use the product described in this manual for devices or systems relating to transportation, health care, space aviation, atomic power, electric power, or in underwater applications must first contact Yaskawa or a Yaskawa representative.

WARNING! Injury to Personnel. *This product has been manufactured under strict quality-control guidelines. However, if this product is to be installed in any location where failure of this product could involve or result in a life-and-death situation or loss of human life or in a facility where failure may cause a serious accident or physical injury, safety devices must be installed to minimize the likelihood of any accident.*

i.2 Receiving

◆ Model Number and Nameplate Check

Please perform the following tasks after receiving the drive:

- Inspect the drive for damage.
If the drive appears damaged upon receipt, contact the shipper immediately.
- Verify receipt of the correct model by checking the information on the nameplate.
- If you have received the wrong model or the drive does not function properly, contact your supplier.

◆ Nameplate

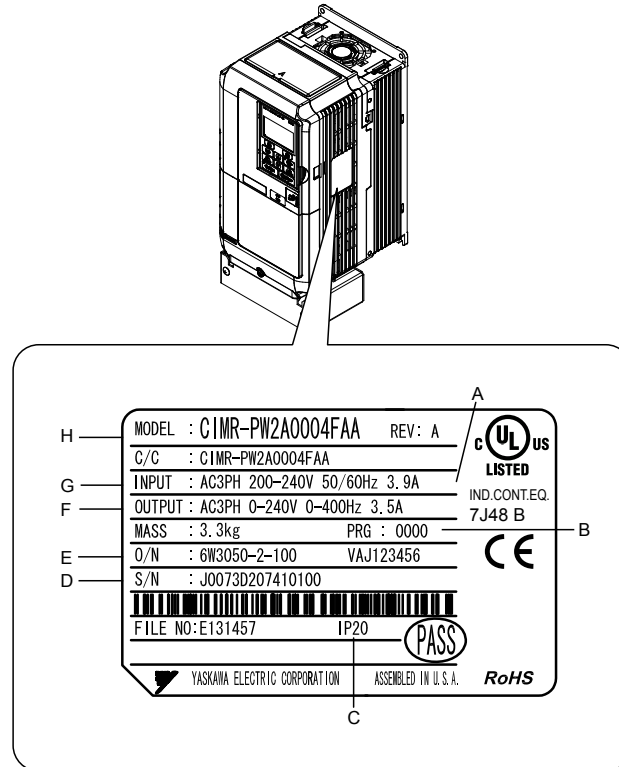

A – Normal Duty Amps

B – Software version

C – Enclosure type

D – Serial number

E – Lot number

F – Output specifications

G – Input specifications

H – AC drive model

Figure i.3 Nameplate Information Example

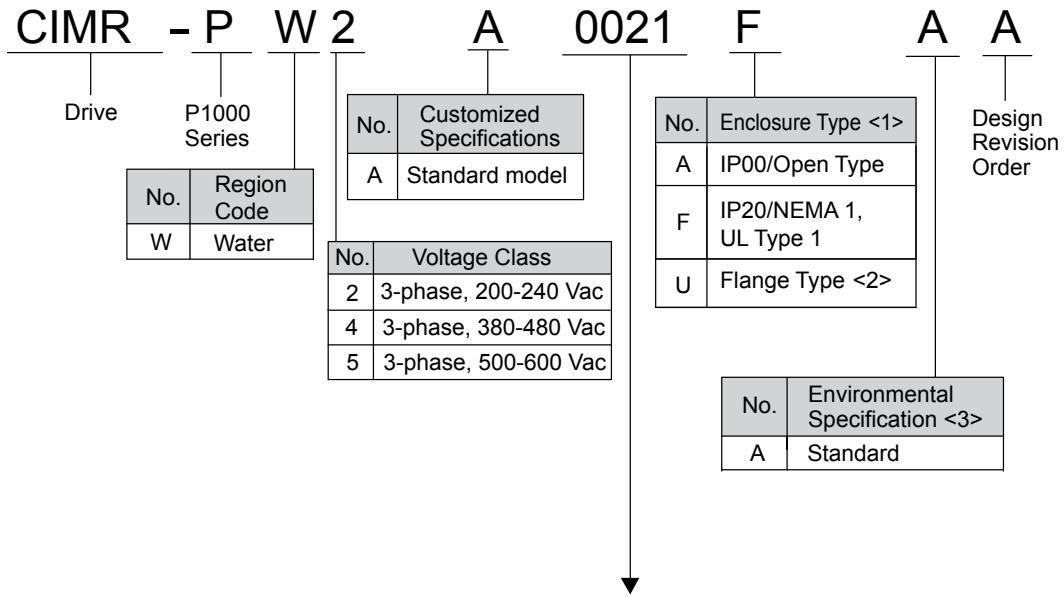

Refer to the tables below

- <1> [Refer to on page 14](#) for differences regarding enclosure protection types and component descriptions.
- <2> Provides method of mounting drive with backside (heatsink) external to enclosure, with NEMA 12 integrity.
- <3> Please contact Yaskawa for details regarding Environmental Specifications.

■ **Three-Phase 200 V Class**

Drive Model	Max. Motor Capacity kW (HP)	Rated Output Current A
2A0004	0.75 (0.75)	3.5
2A0006	1.1 (1)	6.0
2A0008	1.5 (2)	8.0
2A0010	2.2 (3)	9.6
2A0012	3.0 (3)	12
2A0018	3.7 (5)	17.5
2A0021	5.5 (7.5)	21
2A0030	7.5 (10)	30
2A0040	11 (15)	40
2A0056	15 (20)	56
2A0069	18.5 (25)	69
2A0081	22 (30)	81
2A0110	30 (40)	110
2A0138	37 (50)	138
2A0169	45 (60)	169
2A0211	55 (75)	211
2A0250	75 (100)	250
2A0312	90 (125)	312
2A0360	110 (150)	360
2A0415	110 (175)	415

■ Three-Phase 400 V Class

Drive Model	Max. Motor Capacity kW (HP)	Rated Output Current A
4A0002	0.75 (0.75)	2.1
4A0004	1.5 (2)	4.1
4A0005	2.2 (3)	5.4
4A0007	3.0 (3)	6.9
4A0009	3.7 (5)	8.8
4A0011	5.5 (7.5)	11.1
4A0018	7.5 (10)	17.5
4A0023	11 (15)	23
4A0031	15 (20)	31
4A0038	18.5 (25)	38
4A0044	22 (30)	44
4A0058	30 (40)	58
4A0072	37 (50)	72
4A0088	45 (60)	88
4A0103	55 (75)	103
4A0139	75 (100)	139
4A0165	90 (125)	165
4A0208	110 (150)	208
4A0250	132 (200)	250
4A0296	160 (250)	296
4A0362	185 (300)	362
4A0414	220 (350)	414
4A0515	250 (400-450)	515
4A0675	355 (500-550)	675
4A0930	500 (750)	930
4A1200	630 (1000)	1200

■ Three-Phase 600 V Class

Drive Model	Max. Motor Capacity kW (HP)	Rated Output Current A
5A0003	1.5 (2)	2.7
5A0004	2.2 (3)	3.9
5A0006	3.7 (5)	6.1
5A0009	5.5 (7.5)	9
5A0011	7.5 (10)	11
5A0017	11 (15)	17
5A0022	15 (20)	22
5A0027	18.5 (25)	27
5A0032	22 (30)	32
5A0041	30 (40)	41
5A0052	37 (50)	52
5A0062	45 (60)	62
5A0077	55 (75)	77
5A0099	75 (100)	99
5A0125	90 (125)	125
5A0145	110 (150)	145
5A0192	160 (200)	192
5A0242	185 (250)	242

i.3 Mechanical Installation

This section outlines specifications, procedures, and environment for proper mechanical installation of the drive.

◆ Installation Environment

Install the drive in an environment matching the specifications in [Table i.1](#) to help prolong the optimum performance life of the drive.

Table i.1 Installation Environment

Environment	Conditions
Installation Area	Indoors
Ambient Temperature	-10 °C to +40 °C (IP20/NEMA 1, UL Type 1 enclosure) -10 °C to +50 °C (IP00/Open Type enclosure) Drive reliability improves in environments without wide temperature fluctuations. When using the drive in an enclosure panel, install a cooling fan or air conditioner in the area to ensure that the air temperature inside the enclosure does not exceed the specified levels. Do not allow ice to develop on the drive.
Humidity	95% RH or less and free of condensation
Storage Temperature	-20 to +60 °C
Surrounding Area	Install the drive in an area free from: <ul style="list-style-type: none"> • oil mist and dust • metal shavings, oil, water, or other foreign materials • radioactive materials • combustible materials (e.g., wood) • harmful gases and liquids • excessive vibration • chlorides • direct sunlight.
Altitude	1000 m or lower, up to 3000 m with derating
Vibration	10 to 20 Hz at 9.8 m/s ² (32.15 ft/s ²) <1> 20 to 55 Hz at 5.9 m/s ² (19.36 ft/s ²) (Models 2A0004 to 2A0211, 4A0002 to 4A0165, and 5A0003 to 5A0099) or 2.0 m/s ² (6.56 ft/s ²) (Models 2A0250 to 2A0415, 4A0208 to 4A1200, and 5A0125 to 5A0242)
Orientation	Install the drive vertically to maintain maximum cooling effects.

<1> Models 4A0930 and 4A1200 are rated at 5.9 m/s² (19.36 ft/s²)

NOTICE: Avoid placing drive peripheral devices, transformers, or other electronics near the drive as the noise created can lead to erroneous operation. If such devices must be used in close proximity to the drive, take proper steps to shield the drive from noise.

NOTICE: Prevent foreign matter such as metal shavings and wire clippings from falling into the drive during installation. Failure to comply could result in damage to the drive. Place a temporary cover over the top of the drive during installation. Remove the temporary cover before drive start-up, as the cover will reduce ventilation and cause the drive to overheat.

◆ Installation Orientation and Spacing

NOTICE: Install the drive upright as illustrated in [Figure i.4](#). Failure to comply may damage the drive due to improper cooling.

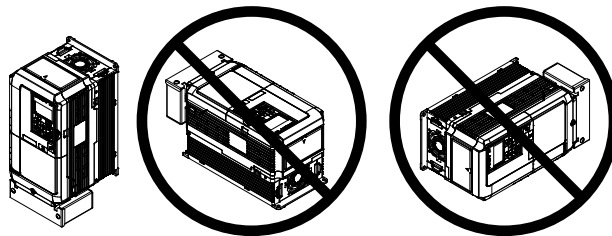

Figure i.4 Correct Installation Orientation

NOTICE: Install the drive upright as specified in the manual. Failure to comply may damage the drive due to improper cooling.

Single Drive Installation

Figure i.5 shows the installation distance required to maintain sufficient space for airflow and wiring. Install the heatsink against a closed surface to avoid diverting cooling air around the heatsink.

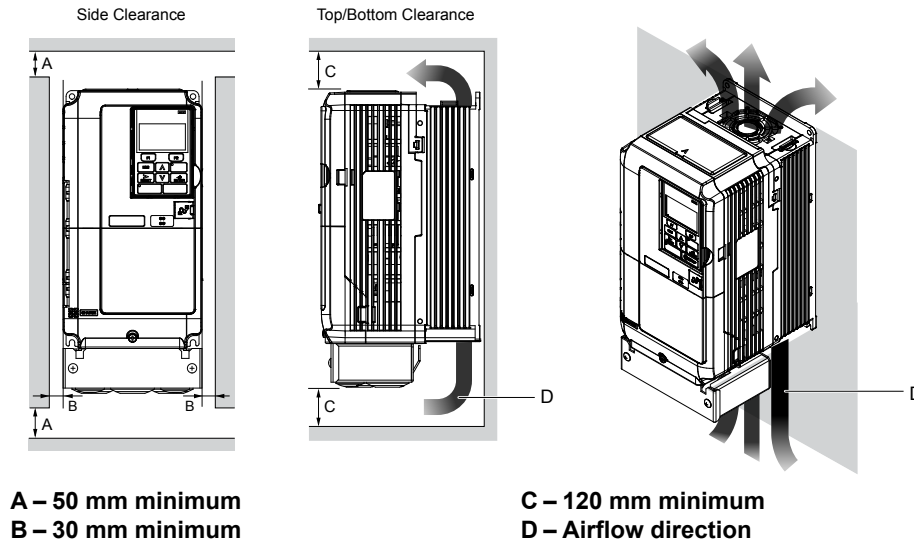

Figure i.5 Correct Installation Spacing

Note: IP20/UL Type 1 enclosure and IP00/Open Type enclosure models require the same amount of space above and below the drive for installation.

Multiple Drive Installation (Side-by-Side Installation)

Models 2A0004 to 2A0081, 4A0002 to 4A0044, and 5A0003 to 5A0032 can take advantage of Side-by-Side installation. When installing multiple drives into the same enclosure panel, mount the drives according to Figure i.5 and set L8-35, Installation Method Selection, to 1 (Side-by-Side Mounting).

When mounting drives with the minimum clearance of 2 mm according to Figure i.6, set parameter L8-35 to 1 while considering derating.

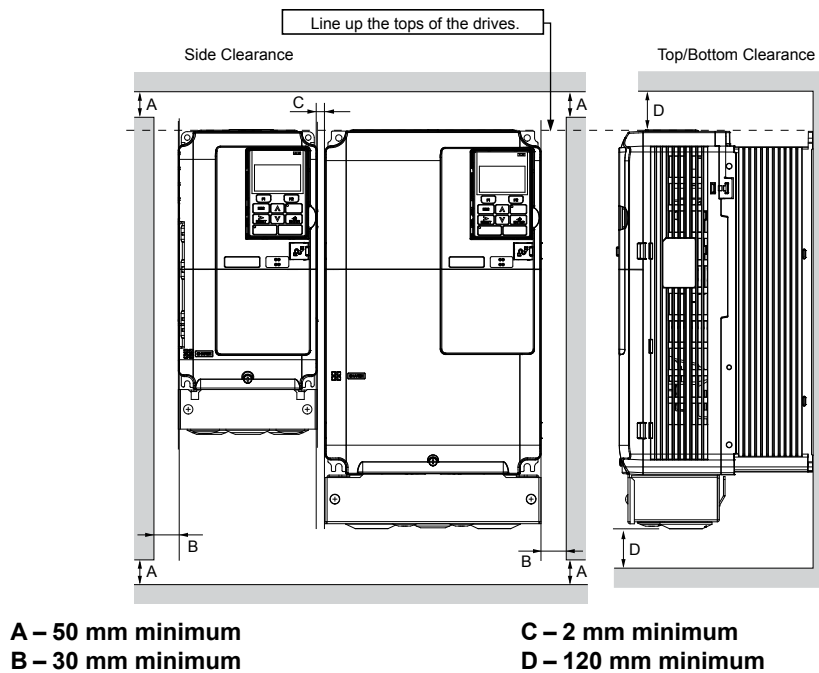

Figure i.6 Space Between Drives (Side-by-Side Mounting)

Note: Align the tops of the drives when installing drives of different heights in the same enclosure panel. Leave space between the tops and bottoms of stacked drives for easier cooling fan replacement.

i.3 Mechanical Installation

Remove the top protective covers of all drives as shown in [Figure i.7](#) when mounting IP20/NEMA 1, UL Type 1 enclosure drives side-by-side. Refer to the drive Quick Start Guide for instructions on removing and reattaching the top protective cover.

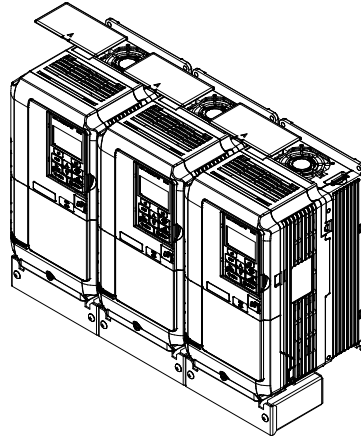

Figure i.7 IP20/NEMA 1, UL Type 1 Side-by-Side Mounting in Enclosure

◆ Instructions on Installation Using the Eye Bolts

Eye bolts are used to install the drive or to temporarily lift the drive when replacing it. Using the eye bolts, the drive can be installed in an enclosure panel or on a wall. Do not leave the drive suspended by the wires in a horizontal or vertical position for long periods of time. Do not transport the drive over long distances. Read the following precautions and instructions before installing the drive.

WARNING! Crush Hazard. Observe the following instructions and precautions. Failure to comply could result in serious injury or death from falling equipment.

Only use vertical suspension to temporarily lift the drive during installation to an enclosure panel. Do not use vertical suspension to transport the drive.

Use screws to securely affix the drive front cover, terminal blocks, and other drive components prior to vertical suspension.

Do not subject the drive to vibration or impact greater than 1.96 m/s^2 (0.2 G) while it is suspended by the wires.

Do not leave the drive unattended while it is suspended by the wires.

Do not attempt to flip the drive over while it is suspended by the wires.

■ Horizontal Suspension of Drive Models 2A0360, 2A0415, and 4A0250 to 4A0675

To make a wire hanger or frame for use when lifting the drive with a crane, lay the drive in a horizontal position and pass a wire through the holes of the four eye bolts.

NOTICE: Damage to Equipment. When lifting the drive, confirm that the spring washer is fully closed. Failure to comply may deform or damage the drive when lifted.

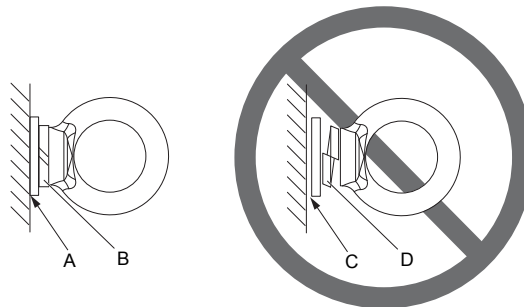

A – No space between drive and washer
B – Spring washer fully closed

C – Space between drive and washer
D – Spring washer open

Figure i.8 Spring Washer

■ Vertical Suspension of Drive Models 2A0360, 2A0415, and 4A0250 to 4A1200

Models 2A0360, 2A0415, and 4A0250 to 4A0675

When vertical suspension of the drive is required in an enclosure panel, change the orientation of the eye bolts for these models by turning the eye bolts counterclockwise 90 degrees.

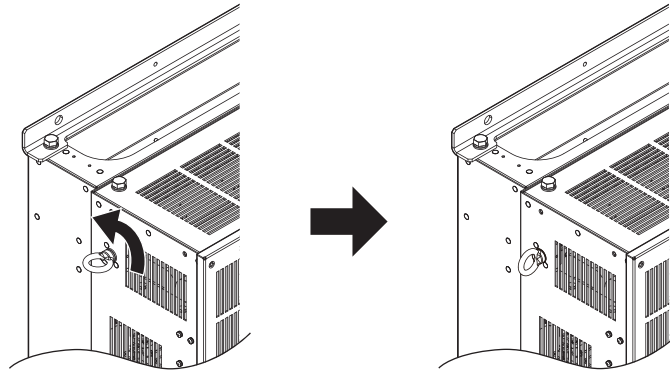

Figure i.9 Adjusting Angle of Eye Bolts

Models 4A0930 and 4A1200

When suspending models 4A0930 or 4A1200 with wires, follow the procedure described below.

WARNING! Crush Hazard. Use an adequate length of wire to ensure a 50° or wider suspension angle as illustrated in [Figure i.11](#). The maximum allowable load of the eye bolts cannot be guaranteed when the drive is suspended with the wires at angles less than 50°. Failure to comply may result in serious injury or death from falling equipment.

1. Remove the four eye bolts from the drive side panels and fix them securely on the top panel.

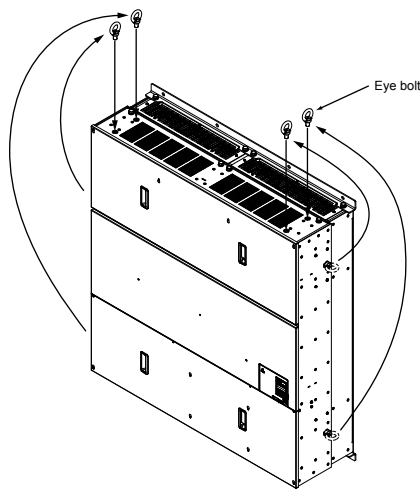
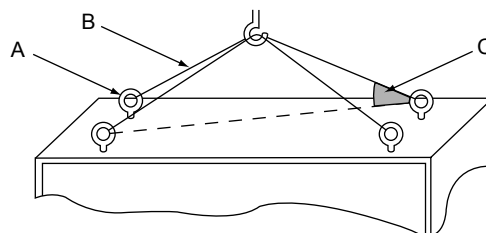

Figure i.10 Eye Bolt Repositioning

2. Pass wire through the holes of all four eye bolts.



A – Eye bolt
B – Wires

C – Suspending angle: 50° or greater

Figure i.11 Suspension Wire Angle Example

3. Gradually take up the slack in the wires and hoist the drive after the wires are stretched tight.
4. Lower the drive when ready to install in the enclosure panel. Stop lowering the drive when it is near the floor then begin lowering the drive again very slowly until the drive is placed correctly.

◆ Drive Dimensions

NOTICE

Refer to the iQpump1000 Drive User Manual TOEP YAIP1W 01 for IP20/NEMA 1, UL Type 1 and IP00/Open Chassis dimensions.

The iQpump1000 Drive User Manual is posted on the Yaskawa website, www.yaskawa.com.

i.4 Electrical Installation

◆ Standard Connection Diagram

Connect the drive and peripheral devices as shown in [Figure i.12](#). It is possible to set and run the drive via the digital operator without connecting digital I/O wiring. This section does not discuss drive operation; refer to the drive User Manual for instructions on operating the drive.

NOTICE: *Inadequate wiring could result in damage to the drive. Install adequate branch circuit short circuit protection per applicable codes. The drive is suitable for circuits capable of delivering not more than 100,000 RMS symmetrical amperes, 240 Vac maximum (200 V class), 480 Vac maximum (400 V class), 600 Vac maximum (600 V class).*

NOTICE: *When the input voltage is 440 V or higher or the wiring distance is greater than 100 meters, pay special attention to the motor insulation voltage or use a drive duty motor. Failure to comply could lead to motor insulation breakdown.*

NOTICE: *Do not connect AC control circuit ground to drive enclosure. Improper drive grounding can cause control circuit malfunction.*

Note: The minimum load for the relay outputs M1-M2, M3-M4, MA-MB-MC, and MD-ME-MF is 10 mA.

i.4 Electrical Installation

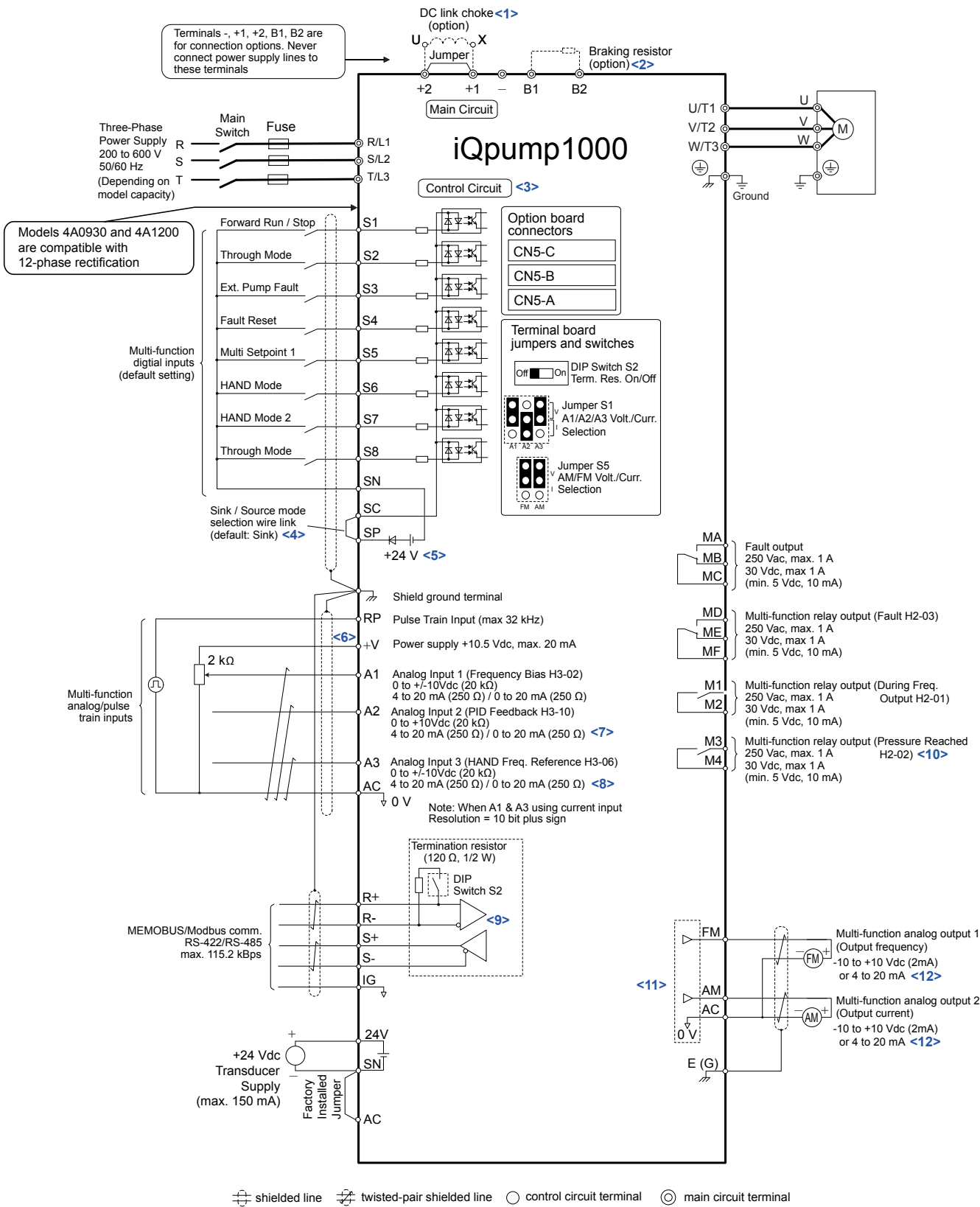

Figure i.12 Drive Standard Connection Diagram (example: model 2A0040)

- <1> Remove the jumper when installing a DC link choke. Models 2A0110 to 2A0415 and 4A0058 to 4A1200 come with a built-in DC link choke.
- <2> Set L8-55 to 0 to disable the protection function of the built-in braking transistor of the drive when using an optional regenerative converter or dynamic braking option. Leaving L8-55 enabled may cause a braking resistor fault (rF). Additionally, disable Stall Prevention (L3-04 = 0) when using an optional regenerative converter, regenerative or braking units, or dynamic braking option. Leaving L3-04 enabled may prevent the drive from stopping within the specified deceleration time.
- <3> Supplying power to the control circuit separately from the main circuit requires 24 V power supply (option).
- <4> This figure illustrates an example of a sequence input to S1 through S8 using a non-powered relay or an NPN transistor. Install the wire link between terminals SC-SP for Sink mode, between SC-SN for Source mode, or leave the link out for external power supply. Never short terminals SP and SN, as it will damage the drive.
- <5> This voltage source supplies a maximum current of 150 mA.
- <6> The maximum output current capacity for the +V terminal on the control circuit is 20 mA. Never short terminals +V and AC, as it can cause erroneous operation or damage the drive.
- <7> Set jumper S1 to select between a voltage or current input signal to terminal A2. The default setting is for current input.
- <8> Set jumper S1 to select between a voltage or current input signal to terminal A1 and A3. The default setting is for voltage input.
- <9> Set DIP switch S2 to the ON position to enable the termination resistor in the last drive in a MEMOBUS/Modbus network.
- <10> H2-02 Default = F (Through Mode) in drive software versions PRG: 8551 and earlier.
- <11> Use jumper S5 to select between voltage or current output signals at terminals AM and FM. Set parameters H4-07 and H4-08 accordingly.
- <12> Monitor outputs work with devices such as analog frequency meters, ammeters, voltmeters, and wattmeters. They are not intended for use as a feedback-type signal.

WARNING! Sudden Movement Hazard. Do not close the wiring for the control circuit unless the multifunction input terminal parameters are properly set. Improper sequencing of run/stop circuitry could result in death or serious injury from moving equipment.

WARNING! Sudden Movement Hazard. Ensure start/stop and safety circuits are wired properly and in the correct state before energizing the drive. Failure to comply could result in death or serious injury from moving equipment. When programmed for 3-Wire control, a momentary closure on terminal S1 may cause the drive to start.

WARNING! Sudden Movement Hazard. Confirm the drive I/O signals and external sequence before executing the application preset function. Executing the application preset function or setting A1-03 ≠ 0 will change the drive I/O terminal functions and may cause unexpected equipment operation. Failure to comply may cause death or serious injury.

NOTICE: When using the automatic fault restart function with wiring designed to shut off the power supply upon drive fault, make sure the drive does not trigger a fault output during fault restart (L5-02 = 0, default). Failure to comply will prevent the automatic fault restart function from working properly.

◆ Main Circuit Connection Diagram

Refer to diagrams in this section when wiring the main circuit of the drive. Connections may vary based on drive capacity. The DC power supply for the main circuit also provides power to the control circuit.

NOTICE: Do not use the negative DC bus terminal “-” as a ground terminal. This terminal is at high DC voltage potential. Improper wiring connections could damage the drive.

NOTICE: Route motor leads U/T1, V/T2 and W/T3 separate from all other leads to reduce possible interference and noise related issues. Failure to comply may result in abnormal operation of drive and nearby equipment.

- **Three-Phase 200 V Class Models 2A0004 to 2A0081**
- **Three-Phase 400 V Class Models 4A0002 to 4A0044**
- **Three-Phase 600 V Class Models 5A0003 to 5A0032**

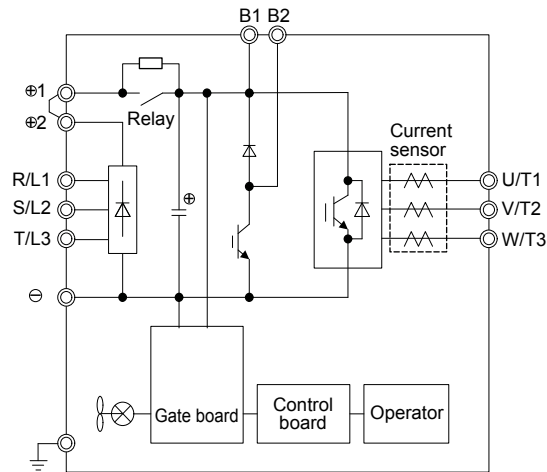

Figure i.13 Connecting Main Circuit Terminals

- **Three-Phase 200 V Class Models 2A0110, 2A0138**
- **Three-Phase 400 V Class Models 4A0058, 4A0072**
- **Three-Phase 600 V Class Models 5A0041, 5A0052**

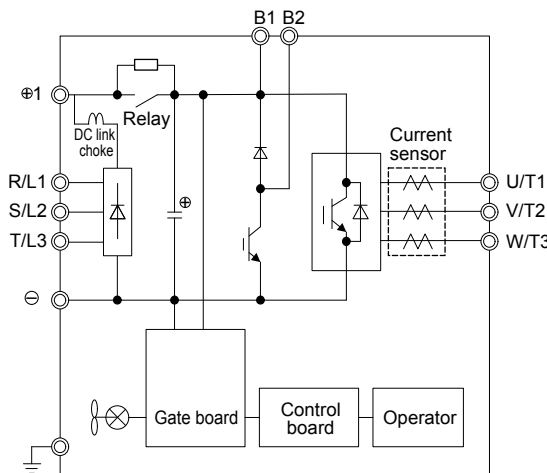

Figure i.14 Connecting Main Circuit Terminals

- Three-Phase 200 V Class Models 2A0169 to 2A0211
- Three-Phase 400 V Class Models 4A0088 to 4A0139
- Three-Phase 600 V Class Models 5A0062 to 5A0099

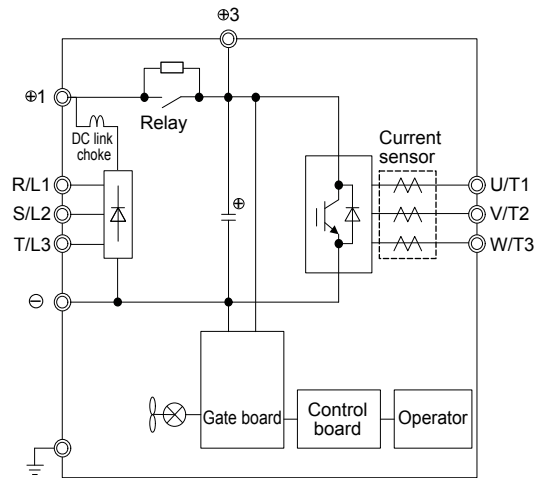

Figure i.15 Connecting Main Circuit Terminals

- Three-Phase 200 V Class Models 2A0250 to 2A0415
- Three-Phase 400 V Class Models 4A0165 to 4A0675
- Three-Phase 600 V Class Models 5A0125 to 5A0242

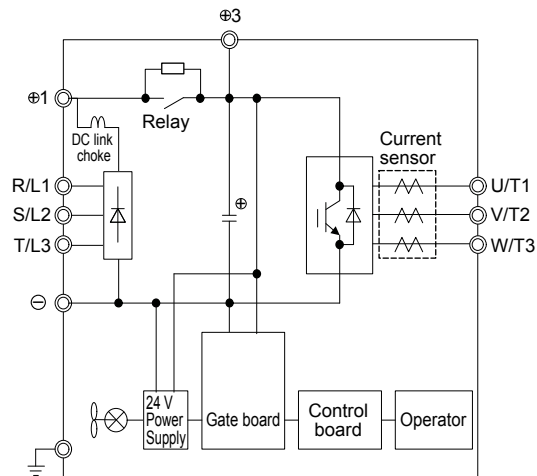

Figure i.16 Connecting Main Circuit Terminals

■ Three-Phase 400 V Class Models 4A0930, 4A1200

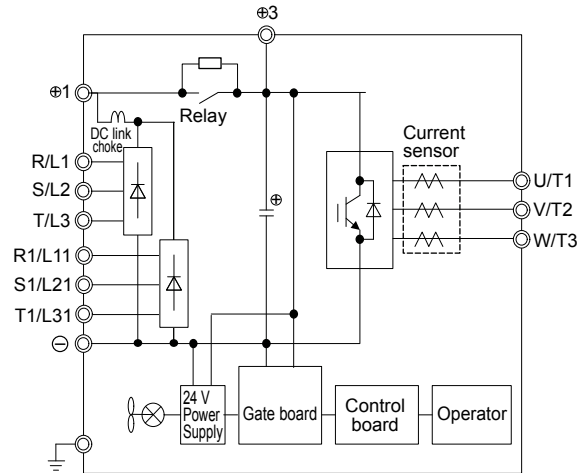

Figure i.17 Connecting Main Circuit Terminals

Note: Models 4A0930 and 4A1200 are compatible for operation with 12-phase rectification.

◆ Main Circuit Wiring

This section describes the functions, specifications, and procedures required to safely and properly wire the main circuit in the drive.

NOTICE: Do not solder the ends of wire connections to the drive. Soldered wiring connections can loosen over time. Improper wiring practices could result in drive malfunction due to loose terminal connections.

NOTICE: Do not switch the drive input to start or stop the motor. Frequently switching the drive on and off shortens the life of the DC bus charge circuit and the DC bus capacitors, and can cause premature drive failures. For the full performance life, refrain from switching the drive on and off more than once every 30 minutes.

Refer to Factory Recommended Branch Circuit Protection for UL Compliance on page 107 for details on fuse selection.

◆ Factory Recommended Branch Circuit Protection

WARNING! Fire Hazard. Install adequate branch circuit protection according to applicable local codes and this manual. Failure to comply could result in fire and damage to the drive or injury to personnel. The device is suitable for use on a circuit capable of delivering not more than 100,000 RMS symmetrical amperes, 240 Vac (200 V class) and 480 Vac (400 V class), when protected by branch circuit protection devices specified in this manual.

Branch circuit protection shall be provided by any of the following: Non-time delay Class J, T, or CC fuses sized at 300% of the drive input rating, or Time delay Class J, T, or CC fuses sized at 175% of the drive input rating, or MCCB sized at 200% maximum of the drive input rating.

Yaskawa recommends installing branch circuit protection according to maintain compliance with UL508C. Semiconductor protective type fuses are preferred. Alternate branch circuit protection devices are also listed in this manual. *Refer to Factory Recommended Branch Circuit Protection on page 98* for details.

◆ Main Circuit Terminal Functions

Table i.2 Main Circuit Terminal Functions

Terminal		Type				Function	Page
200 V Class	Drive Model	2A0004 to 2A0081	2A0110, 2A0138	2A0169 to 2A0415	–		
400 V Class		4A0002 to 4A0044	4A0058, 4A0072	4A0088 to 4A0675	4A0930, 4A1200		
600 V Class		5A0003 to 5A0032	5A0041, 5A0052	5A0062 to 5A0242	–		
R/L1		Main circuit power supply input				Connects line power to the drive	20
S/L2							
T/L3							
R1-L11		Not available		Main circuit power supply input	Connects line power to the drive Remove the shorting bars connecting R/L1-R1/L11, S/L2-S1/L21, T/L3-T1/L31 when using 12-pulse rectification.	20	
S1-L21							
T1-L31							
U/T1		Drive output				Connects to the motor	20
V/T2							
W/T3							
B1		Braking resistor		Not available		Available for connecting a braking resistor or a braking resistor unit option	–
B2							
⊕2	<ul style="list-style-type: none"> DC link choke connection (⊕1, ⊕2) (remove the shorting bar between ⊕1 and ⊕2) DC power supply input (⊕1, ⊖) 	Not available				For connecting: <ul style="list-style-type: none"> the drive to a DC power supply dynamic braking options a DC link choke 	–
⊕1							
⊖							
⊕3		Not available					
⊕		For 200 V class: 100 Ω or less For 400 V class: 10 Ω or less For 600 V class: 10 Ω or less				Grounding terminal	35

Note: Use terminals B1 and ⊖ when installing a CDBR-type braking unit on drives with built-in braking transistors (Models 2A0004 to 2A0138, 4A0002 to 4A0072, and 5A0003 to 5A0052).

Wiring Fuses for Models 4A0930 and 4A1200

NOTICE: If a fuse is blown or an Ground Fault Circuit Interrupter (GFCI) is tripped, check the wiring and the selection of peripheral devices to identify the cause. Contact Yaskawa before restarting the drive or the peripheral devices if the cause cannot be identified.

Install a fuse on the input side to protect drive wiring and prevent other secondary damage. Wire the fuse so that leakage current in the upper controller power supply will trigger the fuse and shut off the power supply.

Select the appropriate fuse from [Table i.3](#).

Table i.3 Input Fuses for Models 4A0930 and 4A1200

Voltage Class	Model	Selection			Input Fuse (Example)			
		Input Voltage	Current	Pre-arc I ² t (A ² s)	Model	Manufacturer	Rating	Pre-arc I ² t (A ² s)
Three-Phase 400 V Class	4A0930	480 V	1500 A	140000 to 3100000	CS5F-1200	Fuji Electric	AC500 V, 1200 A	276000
	4A0930 with 12-pulse rectification				FWH-1200A	Bussman	AC500 V, 1200 A	–
					FWH-1000A	Bussman	AC500 V, 1000 A	–
	4A1200	480 V	1500 A	320000 to 3100000	CS5F-1500	Fuji Electric	AC500 V, 1500 A	351000
	4A1200 with 12-pulse rectification				FWH-1600A	Bussman	AC500 V, 1600 A	–
					FWH-1200A	Bussman	AC500 V, 1200 A	–

◆ Protecting Main Circuit Terminals

■ Insulation Caps or Sleeves

Use insulation caps or sleeves when wiring the drive with crimp terminals. Take particular care to ensure that the wiring does not touch nearby terminals or the surrounding case.

■ Insulation Barrier

Insulation barriers are packaged with drive models 4A0414 through 4A1200 to provide added protection between terminals. Yaskawa recommends using the provided insulation barriers to ensure proper wiring. Refer to [Figure i.18](#) for instructions on placement of the insulation barriers.

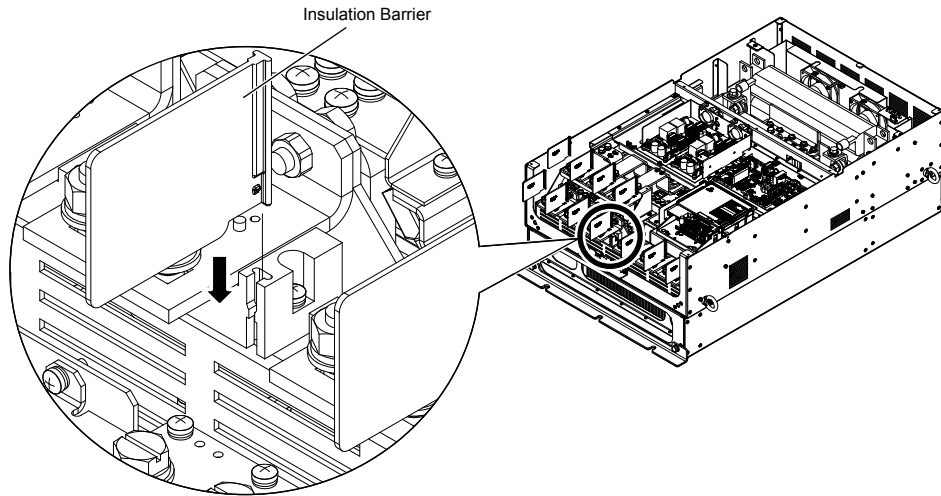

Figure i.18 Installing Insulation Barriers

◆ Main Circuit Wire Gauges and Tightening Torques

Use the tables in this section to select the appropriate wires and crimp terminals.

Gauges listed in the tables are for use in the United States.

- Note:**
1. Wire gauge recommendations based on drive continuous current ratings (ND) using 75 °C 600 Vac vinyl-sheathed wire assuming ambient temperature within 40 °C and wiring distance less than 100 m.
 2. Terminals ⊕1, ⊕2, ⊕3, ⊖, B1 and B2 are for connecting optional power devices. Use caution to connect only approved devices to the correct terminal(s).

- Consider the amount of voltage drop when selecting wire gauges. Increase the wire gauge when the voltage drop is greater than 2% of motor rated voltage. Ensure the wire gauge is suitable for the terminal block. Use the following formula to calculate the amount of voltage drop:

$$\text{Line drop voltage (V)} = \sqrt{3} \times \text{wire resistance } (\Omega/\text{km}) \times \text{wire length (m)} \times \text{current (A)} \times 10^{-3}$$

- Refer to instruction manual TOBPC72060000 or TOBPC72060001 for braking transistor option or braking resistor option wire gauges.
- Use terminals ⊕1 and ⊖ when connecting a regenerative converter or a regen unit.

NOTICE: Do not connect a braking resistor to terminals ⊕1 or ⊖. Failure to comply may cause damage to the drive circuitry.

- Use terminals B1 and ⊖ when installing a CDBR-type braking unit on drives with built-in braking transistors (models 2A0004 to 2A0138, 4A0002 to 4A0072, and 5A0003 to 5A0052).

NOTICE: Do not connect a braking resistor to terminals ⊕1 or ⊖. Failure to comply may cause damage to the drive circuitry.

- [Refer to UL Standards Compliance on page 103](#) for information on UL compliance.

Yaskawa recommends using closed-loop crimp terminals on all drive models. UL/cUL approval requires the use of closed-loop crimp terminals when wiring the drive main circuit terminals on models 2A0110 to 2A0415 and 4A0058 to 4A1200. Use only the tools recommended by the terminal manufacturer for crimping. [Refer to Closed-Loop Crimp Terminal Size on page 103](#) for closed-loop crimp terminal recommendations.

The wire gauges listed in the following tables are Yaskawa recommendations. Refer to local codes for proper wire gauge selections.

■ Three-Phase 200 V Class

Table i.4 Wire Gauge and Torque Specifications (Three-Phase 200 V Class)

Drive Model	Terminal	Recomm. Gauge AWG, kcmil	Wire Range AWG, kcmil	Screw Size	Tightening Torque N·m (lb.in.)
2A0004 2A0006 2A0008 2A0010	R/L1, S/L2, T/L3	14	14 to 10	M4	1.2 to 1.5 (10.6 to 13.3)
	U/T1, V/T2, W/T3	14	14 to 10		
	⊖, ⊕1, ⊕2	–	14 to 10		
	B1, B2	–	14 to 10		
	⊕	10 <?>	14 to 10		
2A0012	R/L1, S/L2, T/L3	12	14 to 10	M4	1.2 to 1.5 (10.6 to 13.3)
	U/T1, V/T2, W/T3	14	14 to 10		
	⊖, ⊕1, ⊕2	–	14 to 10		
	B1, B2	–	14 to 10		
	⊕	10 <?>	14 to 10		
2A0018	R/L1, S/L2, T/L3	10	12 to 10	M4	1.2 to 1.5 (10.6 to 13.3)
	U/T1, V/T2, W/T3	10	14 to 10		
	⊖, ⊕1, ⊕2	–	14 to 10		
	B1, B2	–	14 to 10		
	⊕	10 <?>	14 to 10		
2A0021	R/L1, S/L2, T/L3	10	12 to 10	M4	1.2 to 1.5 (10.6 to 13.3)
	U/T1, V/T2, W/T3	10	12 to 10		
	⊖, ⊕1, ⊕2	–	12 to 10		
	B1, B2	–	14 to 10		
	⊕	10 <?>	12 to 10		
2A0030	R/L1, S/L2, T/L3	8	10 to 6	M4	2.1 to 2.3 (18.6 to 20.4)
	U/T1, V/T2, W/T3	8	10 to 6		
	⊖, ⊕1, ⊕2	–	10 to 6		
	B1, B2	–	14 to 10		
	⊕	8 <?>	10 to 8	M5	2.0 to 2.5 (17.7 to 22.1)
2A0040	R/L1, S/L2, T/L3	6	8 to 6	M4	2.1 to 2.3 (18.6 to 20.4)
	U/T1, V/T2, W/T3	8	8 to 6		
	⊖, ⊕1, ⊕2	–	6		
	B1, B2	–	12 to 10		
	⊕	8 <?>	10 to 8	M5	2.0 to 2.5 (17.7 to 22.1)
2A0056	R/L1, S/L2, T/L3	4	6 to 4	M6	5.4 to 6.0 (47.8 to 53.1)
	U/T1, V/T2, W/T3	4	6 to 4		
	⊖, ⊕1, ⊕2	–	6 to 4		
	B1, B2	–	10 to 6	M5	2.7 to 3.0 (23.9 to 26.6)
	⊕	6	8 to 6	M6	5.4 to 6.0 (47.8 to 53.1)
2A0069	R/L1, S/L2, T/L3	3	4 to 3	M8	9.9 to 11.0 (87.6 to 97.4)
	U/T1, V/T2, W/T3	3	4 to 3		
	⊖, ⊕1, ⊕2	–	4 to 3		
	B1, B2	–	8 to 6	M5	2.7 to 3.0 (23.9 to 26.6)
	⊕	6	6 to 4	M6	5.4 to 6.0 (47.8 to 53.1)

i.4 Electrical Installation

Drive Model	Terminal	Recomm. Gauge AWG, kcmil	Wire Range AWG, kcmil	Screw Size	Tightening Torque N·m (lb.in.)
2A0081	R/L1, S/L2, T/L3	2	3 to 2	M8	9.9 to 11.0 (87.6 to 97.4)
	U/T1, V/T2, W/T3	2	3 to 2		
	⊖, ⊕1, ⊕2	–	3 to 2		
	B1, B2	–	6	M5	2.7 to 3.0 (23.9 to 26.6)
	⊕	6	6 to 4	M6	5.4 to 6.0 (47.8 to 53.1)
2A0110	R/L1, S/L2, T/L3	1/0	3 to 1/0	M8	9 to 11 (79.7 to 97.4)
	U/T1, V/T2, W/T3	1/0	3 to 1/0		
	⊖, ⊕1	–	2 to 1/0		
	B1, B2	–	6 to 1/0		
	⊕	6	6 to 4		
2A0138	R/L1, S/L2, T/L3	2/0	1 to 2/0	M10	18 to 23 (159 to 204)
	U/T1, V/T2, W/T3	2/0	1 to 2/0		
	⊖, ⊕1	–	1/0 to 3/0		
	B1, B2	–	4 to 2/0		
	⊕	4	4	M8	9 to 11 (79.7 to 97.4)
2A0169	R/L1, S/L2, T/L3	4/0	2/0 to 4/0	M10	18 to 23 (159 to 204)
	U/T1, V/T2, W/T3	4/0	3/0 to 4/0		
	⊖, ⊕1	–	1 to 4/0		
	⊕3	–	1/0 to 4/0		
	⊕	4	4 to 2		
2A0211	R/L1, S/L2, T/L3	1/0 × 2P	1/0 to 2/0	M10	18 to 23 (159 to 204)
	U/T1, V/T2, W/T3	1/0 × 2P	1/0 to 2/0		
	⊖, ⊕1	–	1 to 4/0		
	⊕3	–	1/0 to 4/0		
	⊕	4	4 to 1/0		
2A0250	R/L1, S/L2, T/L3	3/0 × 2P	3/0 to 300	M12	32 to 40 (283 to 354)
	U/T1, V/T2, W/T3	3/0 × 2P	3/0 to 300		
	⊖, ⊕1	–	3/0 to 300	M10	18 to 23 (159 to 204)
	⊕3	–	2 to 300		
	⊕	3	3 to 300		
2A0312	R/L1, S/L2, T/L3	4/0 × 2P	3/0 to 300	M12	32 to 40 (283 to 354)
	U/T1, V/T2, W/T3	3/0 × 2P	3/0 to 300		
	⊖, ⊕1	–	3/0 to 300	M10	18 to 23 (159 to 204)
	⊕3	–	3/0 to 300		
	⊕	2	2 to 300		
2A0360	R/L1, S/L2, T/L3	250 × 2P	4/0 to 600	M12	32 to 40 (283 to 354)
	U/T1, V/T2, W/T3	4/0 × 2P	4/0 to 600		
	⊖, ⊕1	–	250 to 600		
	⊕3	–	3/0 to 600	M10	18 to 23 (159 to 204)
	⊕	1	1 to 350	M12	32 to 40 (283 to 354)

Drive Model	Terminal	Recomm. Gauge AWG, kcmil	Wire Range AWG, kcmil	Screw Size	Tightening Torque N·m (lb.in.)
2A0415	R/L1, S/L2, T/L3	350 × 2P	250 to 600	M12	32 to 40 (283 to 354)
	U/T1, V/T2, W/T3	300 × 2P	300 to 600		
	⊖, ⊕1	–	300 to 600		
	⊕3	–	3/0 to 600	M10	18 to 23 (159 to 204)
	⊕	1	1 to 350	M12	32 to 40 (283 to 354)

<1> Install a GFCI when using this wire gauge in accordance with IEC/EN 61800-5-1.

<2> Install a GFCI, or use 10 mm² (AWG 8) copper wire when using this wire gauge in accordance with IEC/EN 61800-5-1.

Note: When connecting peripheral devices or options to terminals ⊖, ⊕1, ⊕3, B1, and B2, refer to the instruction manual for each device. For more information, contact Yaskawa or your nearest sales representative.

■ Three-Phase 400 V Class

Table i.5 Wire Gauge and Torque Specifications (Three-Phase 400 V Class)

Drive Model	Terminal	Recomm. Gauge AWG, kcmil	Wire Range AWG, kcmil	Screw Size	Tightening Torque N·m (lb.in.)
4A0002 4A0004	R/L1, S/L2, T/L3	14	14 to 10	M4	1.2 to 1.5 (10.6 to 13.3)
	U/T1, V/T2, W/T3	14	14 to 10		
	⊖, ⊕1, ⊕2	–	14 to 10		
	B1, B2	–	14 to 10		
	⊕	12 <1>	14 to 12		
4A0005 4A0007 4A0009	R/L1, S/L2, T/L3	14	14 to 10	M4	1.2 to 1.5 (10.6 to 13.3)
	U/T1, V/T2, W/T3	14	14 to 10		
	⊖, ⊕1, ⊕2	–	14 to 10		
	B1, B2	–	14 to 10		
	⊕	10 <1>	14 to 10		
4A0011	R/L1, S/L2, T/L3	12	14 to 10	M4	1.2 to 1.5 (10.6 to 13.3)
	U/T1, V/T2, W/T3	14	14 to 10		
	⊖, ⊕1, ⊕2	–	14 to 10		
	B1, B2	–	14 to 10		
	⊕	10 <1>	14 to 10		
4A0018	R/L1, S/L2, T/L3	10	12 to 6	M4	2.1 to 2.3 (18.6 to 20.4)
	U/T1, V/T2, W/T3	10	12 to 6		
	⊖, ⊕1, ⊕2	–	12 to 6		
	B1, B2	–	12 to 10	M5	2.0 to 2.5 (17.7 to 22.1)
	⊕	10 <1>	14 to 10		
4A0023	R/L1, S/L2, T/L3	10	10 to 6	M4	2.1 to 2.3 (18.6 to 20.4)
	U/T1, V/T2, W/T3	10	10 to 6		
	⊖, ⊕1, ⊕2	–	12 to 6		
	B1, B2	–	12 to 10	M5	2.0 to 2.5 (17.7 to 22.1)
	⊕	10 <1>	12 to 10		
4A0031	R/L1, S/L2, T/L3	8	8 to 6	M5	3.6 to 4.0 (31.8 to 35.4)
	U/T1, V/T2, W/T3	8	10 to 6		
	⊖, ⊕1, ⊕2	–	10 to 6		
	B1, B2	–	10 to 8	M6	2.7 to 3.0 (23.9 to 26.6)
	⊕	8 <2>	10 to 8		

i.4 Electrical Installation

Drive Model	Terminal	Recomm. Gauge AWG, kcmil	Wire Range AWG, kcmil	Screw Size	Tightening Torque N-m (lb.in.)
4A0038	R/L1, S/L2, T/L3	6	8 to 6	M5	3.6 to 4.0 (31.8 to 35.4)
	U/T1, V/T2, W/T3	8	8 to 6		
	⊖, ⊕1, ⊕2	–	6		
	B1, B2	–	10 to 8	M6	2.7 to 3.0 (23.9 to 26.6)
	⊕	6	10 to 6		
4A0044	R/L1, S/L2, T/L3	6	6 to 4	M6	5.4 to 6.0 (47.8 to 53.1)
	U/T1, V/T2, W/T3	6	6 to 4		
	⊖, ⊕1, ⊕2	–	6 to 4		
	B1, B2	–	10 to 8	M5	2.7 to 3.0 (23.9 to 26.6)
	⊕	6	8 to 6	M6	5.4 to 6.0 (47.8 to 53.1)
4A0058	R/L1, S/L2, T/L3	4	6 to 4	M8	9 to 11 (79.7 to 97.4)
	U/T1, V/T2, W/T3	4	6 to 4		
	⊖, ⊕1	–	6 to 1		
	B1, B2	–	8 to 4		
	⊕	6	8 to 6		
4A0072	R/L1, S/L2, T/L3	3	4 to 3	M8	9 to 11 (79.7 to 97.4)
	U/T1, V/T2, W/T3	3	4 to 3		
	⊖, ⊕1	–	4 to 1		
	B1, B2	–	6 to 3		
	⊕	6	6		
4A0088	R/L1, S/L2, T/L3	2	3 to 1/0	M8	9 to 11 (79.7 to 97.4)
	U/T1, V/T2, W/T3	2	3 to 1/0		
	⊖, ⊕1	–	3 to 1/0		
	⊕3	–	6 to 1/0		
	⊕	4	6 to 4		
4A0103	R/L1, S/L2, T/L3	1/0	2 to 1/0	M8	9 to 11 (79.7 to 97.4)
	U/T1, V/T2, W/T3	1	2 to 1/0		
	⊖, ⊕1	–	3 to 1/0		
	⊕3	–	4 to 1/0		
	⊕	4	6 to 4		
4A0139	R/L1, S/L2, T/L3	3/0	1/0 to 4/0	M10	18 to 23 (159 to 204)
	U/T1, V/T2, W/T3	2/0	1/0 to 4/0		
	⊖, ⊕1	–	1/0 to 4/0		
	⊕3	–	3 to 4/0		
	⊕	4	4		
4A0165	R/L1, S/L2, T/L3	4/0	3/0 to 4/0	M10	18 to 23 (159 to 204)
	U/T1, V/T2, W/T3	4/0	3/0 to 4/0		
	⊖, ⊕1	–	1 to 4/0		
	⊕3	–	1/0 to 4/0		
	⊕	4	4 to 2		
4A0208	R/L1, S/L2, T/L3	300	2 to 300	M10	18 to 23 (159 to 204)
	U/T1, V/T2, W/T3	300	2 to 300		
	⊖, ⊕1	–	1 to 250		
	⊕3	–	3 to 3/0		
	⊕	4	4 to 300		

Drive Model	Terminal	Recomm. Gauge AWG, kcmil	Wire Range AWG, kcmil	Screw Size	Tightening Torque N·m (lb.in.)
4A0250	R/L1, S/L2, T/L3	400	1 to 600	M10	18 to 23 (159 to 204)
	U/T1, V/T2, W/T3	400	1/0 to 600		
	⊖, ⊕1	–	3/0 to 600		
	⊕3	–	1 to 325		
	⊕	2	2 to 350		
4A0296	R/L1, S/L2, T/L3	500	2/0 to 600	M12	32 to 40 (283 to 354)
	U/T1, V/T2, W/T3	500	2/0 to 600		
	⊖, ⊕1	–	3/0 to 600		
	⊕3	–	1 to 325	M10	18 to 23 (159 to 204)
	⊕	2	2 to 350	M12	32 to 40 (283 to 354)
4A0362	R/L1, S/L2, T/L3	4/0 × 2P	3/0 to 600	M12	32 to 40 (283 to 354)
	U/T1, V/T2, W/T3	4/0 × 2P	3/0 to 600		
	⊖, ⊕1	–	4/0 to 600		
	⊕3	–	3/0 to 600	M10	18 to 23 (159 to 204)
	⊕	1	1 to 350	M12	32 to 40 (283 to 354)
4A0414	R/L1, S/L2, T/L3	300 × 2P	4/0 to 300	M12	32 to 40 (283 to 354)
	U/T1, V/T2, W/T3	300 × 2P	4/0 to 300		
	⊖, ⊕1	–	3/0 to 300		
	⊕3	–	3/0 to 300		
	⊕	1	1 to 3/0		
4A0515	R/L1, S/L2, T/L3	3/0 × 4P	3/0 to 300	M12	32 to 40 (283 to 354)
	U/T1, V/T2, W/T3	4/0 × 4P	3/0 to 300		
	⊖, ⊕1	–	1/0 to 300		
	⊕3	–	1/0 to 300		
	⊕	1/0	1/0 to 300		
4A0675	R/L1, S/L2, T/L3	300 × 4P	4/0 to 300	M12	32 to 40 (283 to 354)
	U/T1, V/T2, W/T3	300 × 4P	4/0 to 300		
	⊖, ⊕1	–	1/0 to 300		
	⊕3	–	1/0 to 300		
	⊕	2/0	2/0 to 300		
4A0930	R/L1, S/L2, T/L3, R1/L11, S1/L21, T1/L31	4/0 × 4P×2	3/0 to 300	M12	32 to 40 (283 to 354)
	U/T1, V/T2, W/T3	4/0 × 4P×2	3/0 to 300		
	⊖, ⊕1	–	4/0 to 300		
	⊕3	–	4/0 to 300		
	⊕	3/0	3/0 to 250		
4A1200	R/L1, S/L2, T/L3, R1/L11, S1/L21, T1/L31	300 × 4P×2	4/0 to 300	M12	32 to 40 (283 to 354)
	U/T1, V/T2, W/T3	300 × 4P×2	4/0 to 300		
	⊖, ⊕1	–	250 to 300		
	⊕3	–	4/0 to 300		
	⊕	4/0	4/0 to 250		

<1> Install a GFCI when using this wire gauge in accordance with IEC/EN 61800-5-1.

<2> Install a GFCI or use 10 mm² (AWG 8) copper wire when using this wire gauge in accordance with IEC/EN 61800-5-1.

Note: When connecting peripheral devices or options to terminals ⊖, ⊕1, ⊕3, B1, and B2, refer to the instruction manual for each device. For more information, contact Yaskawa or your nearest sales representative.

i.4 Electrical Installation

■ Three-Phase 600 V Class

Table i.6 Wire Gauge and Torque Specifications (Three-Phase 600 V Class)

Drive Model	Terminal	Recomm. Gauge mm ² (AWG, kcmil)	Wire Range mm ² (AWG, kcmil)	Screw Size	Tightening Torque N·m (lb.in.)
5A0003 5A0004 5A0006	R/L1, S/L2, T/L3	2.5 (14)	2.5 to 6.0 (14 to 10)	M4	1.2 to 1.5 (10.6 to 13.3)
	U/T1, V/T2, W/T3	2.5 (14)	2.5 to 6.0 (14 to 10)		
	⊖, ⊕1, ⊕2	–	2.5 to 6.0 (14 to 10)		
	B1, B2	–	2.5 to 6.0 (14 to 10)		
	⊕	6.0 (10)	2.5 to 6.0 (14 to 10)		
5A0009	R/L1, S/L2, T/L3	2.5 (14)	2.5 to 6.0 (14 to 10)	M4	1.2 to 1.5 (10.6 to 13.3)
	U/T1, V/T2, W/T3	2.5 (14)	2.5 to 6.0 (14 to 10)		
	⊖, ⊕1, ⊕2	–	2.5 to 6.0 (14 to 10)		
	B1, B2	–	2.5 to 6.0 (14 to 10)		
	⊕	6.0 (10)	4.0 to 6.0 (12 to 10)		
5A0011	R/L1, S/L2, T/L3	6.0 (10)	2.5 to 16 (14 to 6)	M4	2.1 to 2.3 (18.6 to 20.4)
	U/T1, V/T2, W/T3	2.5 (14)	2.5 to 16 (14 to 6)		
	⊖, ⊕1, ⊕2	–	2.5 to 16 (14 to 6)		
	B1, B2	–	2.5 to 6.0 (14 to 10)		
	⊕	10 (8)	4.0 to 6.0 (12 to 8)	M5	2.0 to 2.5 (17.7 to 22.1)
5A0017	R/L1, S/L2, T/L3	6.0 (10)	6.0 to 16 (10 to 6)	M5	3.6 to 4.0 (31.8 to 35.4)
	U/T1, V/T2, W/T3	6.0 (10)	6.0 to 16 (10 to 6)		
	⊖, ⊕1, ⊕2	–	6.0 to 16 (10 to 6)		
	B1, B2	–	6.0 to 10 (10 to 8)		
	⊕	10 (8)	6.0 to 10 (12 to 8)	M6	5.4 to 6.0 (47.8 to 53.1)
5A0022	R/L1, S/L2, T/L3	10 (8)	6.0 to 16 (10 to 6)	M5	3.6 to 4.0 (31.8 to 35.4)
	U/T1, V/T2, W/T3	6.0 (10)	6.0 to 16 (10 to 6)		
	⊖, ⊕1, ⊕2	–	6.0 to 16 (10 to 6)		
	B1, B2	–	6.0 to 10 (10 to 8)		
	⊕	10 (8)	6.0 to 10 (10 to 6)	M6	5.4 to 6.0 (47.8 to 53.1)

Drive Model	Terminal	Recomm. Gauge mm ² (AWG, kcmil)	Wire Range mm ² (AWG, kcmil)	Screw Size	Tightening Torque N·m (lb.in.)
5A0027 5A0032	R/L1, S/L2, T/L3	16 (6)	16 to 25 (6 to 4)	M6	5.4 to 6.0 (47.8 to 53.1)
	U/T1, V/T2, W/T3	16 (6)	16 to 25 (6 to 4)		
	⊖, ⊕1, ⊕2	–	16 to 25 (6 to 4)		
	B1, B2	–	6.0 to 10 (10 to 8)	M5	2.7 to 3.0 (23.9 to 26.6)
	⊕	16 (6)	10 to 16 (10 to 6)	M6	5.4 to 6.0 (47.8 to 53.1)
5A0041	R/L1, S/L2, T/L3	16 (6)	6.0 to 25 (10 to 3)	M8	9.0 to 11 (79.7 to 97.4)
	U/T1, V/T2, W/T3	16 (6)	6.0 to 25 (10 to 3)		
	⊖, ⊕1	–	(6 to 1)		
	B1, B2	–	4.0 to 25 (12 to 3)		
	⊕	16 (6)	10 to 16 (6)		
5A0052	R/L1, S/L2, T/L3	25 (4)	6.0 to 25 (10 to 3)	M8	9.0 to 11 (79.7 to 97.4)
	U/T1, V/T2, W/T3	16 (6)	6.0 to 25 (10 to 3)		
	⊖, ⊕1	–	16 to 35 (6 to 1)		
	B1, B2	–	10 to 25 (8 to 3)		
	⊕	16 (6)	10 to 16 (6)		
5A0062	R/L1, S/L2, T/L3	25 (4)	6.0 to 95 (10 to 4/0)	M10	18 to 23 (159 to 204)
	U/T1, V/T2, W/T3	25 (4)	6.0 to 95 (10 to 4/0)		
	⊖, ⊕1	–	25 to 95 (4 to 4/0)		
	⊕3	–	16 to 95 (6 to 4/0)		
	⊕	25 (4)	25 (4)		
5A0077	R/L1, S/L2, T/L3	25 (3)	6.0 to 95 (10 to 4/0)	M10	18 to 23 (159 to 204)
	U/T1, V/T2, W/T3	25 (3)	6.0 to 95 (10 to 4/0)		
	⊖, ⊕1	–	25 to 95 (3 to 4/0)		
	⊕3	–	16 to 95 (6 to 4/0)		
	⊕	25 (4)	25 (4)		
5A0099	R/L1, S/L2, T/L3	70 (1/0)	6.0 to 95 (10 to 4/0)	M10	18 to 23 (159 to 204)
	U/T1, V/T2, W/T3	50 (1)	6.0 to 95 (10 to 4/0)		
	⊖, ⊕1	–	35 to 95 (2 to 4/0)		
	⊕3	–	25 to 95 (4 to 4/0)		
	⊕	25 (4)	25 (4)		

i.4 Electrical Installation

Drive Model	Terminal	Recomm. Gauge mm ² (AWG, kcmil)	Wire Range mm ² (AWG, kcmil)	Screw Size	Tightening Torque N·m (lb.in.)
5A0125	R/L1, S/L2, T/L3	70 (2/0)	35 to 150 (1 to 300)	M10	18 to 23 (159 to 204)
	U/T1, V/T2, W/T3	70 (2/0)	35 to 150 (1 to 300)		
	⊖, ⊕1	–	70 (2/0 to 3/0)		
	⊕3	–	35 to 50 (1 to 1/0)		
	⊕	35 (3)	35 to 150 (3 to 300)		
5A0145	R/L1, S/L2, T/L3	95 (3/0)	95 to 150 (2/0 to 300)	M10	18 to 23 (159 to 204)
	U/T1, V/T2, W/T3	95 (3/0)	95 to 150 (2/0 to 300)		
	⊖, ⊕1	–	70 to 95 (3/0 to 4/0)		
	⊕3	–	70 to 95 (1/0 to 2/0)		
	⊕	35 (3)	35 to 150 (3 to 300)		
5A0192	R/L1, S/L2, T/L3	185 (300)	95 to 300 (2/0 to 600)	M12	32 to 40 (283 to 354)
	U/T1, V/T2, W/T3	150 (250)	95 to 300 (2/0 to 600)		
	⊖, ⊕1	–	95 to 185 (2/0 to 400)		
	⊕3	–	95 to 120 (2/0 to 250)	M10	18 to 23 (159 to 204)
	⊕	50 (1)	35 to 300 (1 to 350)	M12	32 to 40 (283 to 354)
5A0242	R/L1, S/L2, T/L3	240 (400)	95 to 300 (2/0 to 600)	M12	32 to 40 (283 to 354)
	U/T1, V/T2, W/T3	185 (350)	95 to 300 (2/0 to 600)		
	⊖, ⊕1	–	95 to 240 (2/0 to 500)		
	⊕3	–	150 (250 to 300)	M10	18 to 23 (159 to 204)
	⊕	50 (1)	35 to 300 (1 to 350)	M12	32 to 40 (283 to 354)

Note: When connecting peripheral devices or options to terminals ⊖, ⊕1, ⊕3, B1, and B2, refer to the instruction manual for each device. For more information, contact Yaskawa or your nearest sales representative.

◆ Main Circuit Terminal and Motor Wiring

This section outlines the various steps, precautions, and checkpoints for wiring the main circuit terminals and motor terminals.

WARNING! *Electrical Shock Hazard. Do not connect the AC power line to the output terminals of the drive. Failure to comply could result in death or serious injury by fire as a result of drive damage from line voltage application to output terminals.*

NOTICE: *When connecting the motor to the drive output terminals U/T1, V/T2, and W/T3, the phase order for the drive and motor should match. Failure to comply with proper wiring practices may cause the motor to run in reverse if the phase order is backward.*

NOTICE: *Route motor leads U/T1, V/T2, and W/T3 separate from all other leads to reduce possible interference related issues. Failure to comply may result in abnormal operation of drive and nearby equipment.*

NOTICE: *Do not connect phase-advancing capacitors or LC/RC noise filters to the output circuits. Failure to comply could result in damage to the drive, phase-advancing capacitors, LC/RC noise filters or ground fault circuit interrupters.*

■ Ground Wiring

Follow the precautions below when wiring the ground for one drive or a series of drives.

WARNING! Electrical Shock Hazard. Make sure the protective earthing conductor complies with technical standards and local safety regulations. Because the leakage current exceeds 3.5 mA in models 4A0414 and larger, IEC/EN 61800-5-1 states that either the power supply must be automatically disconnected in case of discontinuity of the protective earthing conductor or a protective earthing conductor with a cross-section of at least 10 mm² (Cu) or 16 mm² (Al) must be used. Failure to comply may result in death or serious injury.

WARNING! Electrical Shock Hazard. Always use a ground wire that complies with technical standards on electrical equipment and minimize the length of the ground wire. Improper equipment grounding may cause dangerous electrical potentials on equipment chassis, which could result in death or serious injury.

WARNING! Electrical Shock Hazard. Be sure to ground the drive ground terminal (200 V class: ground to 100 Ω or less; 400 V class: ground to 10 Ω or less; 600 V class: ground to 10 Ω or less). Improper equipment grounding could result in death or serious injury by contacting ungrounded electrical equipment.

NOTICE: Do not share the ground wire with other devices such as welding machines or large-current electrical equipment. Improper equipment grounding could result in drive or equipment malfunction due to electrical interference.

NOTICE: When using more than one drive, ground multiple drives according to instructions. Improper equipment grounding could result in abnormal operation of drive or equipment.

Refer to [Figure i.19](#) when using multiple drives. Do not loop the ground wire.

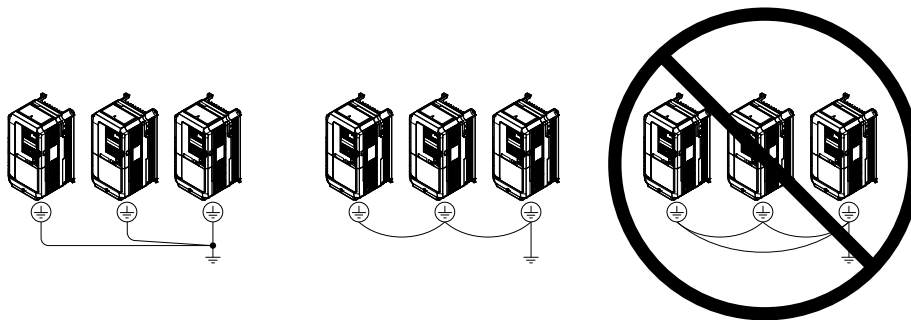

Figure i.19 Multiple Drive Wiring

◆ Control Circuit Terminal Block Functions

Drive parameters determine which functions apply to the multi-function digital inputs (S1 to S8), multi-function digital outputs (M1 to M4), multi-function analog inputs (A1 to A3), and multi-function analog monitor output (FM, AM). The default setting is listed next to each terminal in [Figure i.12](#) on page 20.

WARNING! Sudden Movement Hazard. Always check the operation and wiring of control circuits after being wired. Operating a drive with untested control circuits could result in death or serious injury.

WARNING! Sudden Movement Hazard. Confirm the drive I/O signals and external sequence before starting test run. Setting parameter A1-03 may change the I/O terminal function automatically from the factory setting. Failure to comply may result in death or serious injury.

i.4 Electrical Installation

Input Terminals

Table i.7 lists the input terminals on the drive. Text in parenthesis indicates the default setting for each multi-function input.

Table i.7 Control Circuit Input Terminals

Type	No.	Terminal Name (Function)	Function (Signal Level) Default Setting
Multi-Function Digital Inputs	S1	Multi-function input 1 (Closed: Forward run, Open: Stop)	<ul style="list-style-type: none"> • Photocoupler • 24 Vdc, 8 mA • <i>Refer to Sinking/Sourcing Mode for Digital Inputs on page 40.</i>
	S2	Multi-function input 2 (Through mode)	
	S3	Multi-function input 3 (External pump fault, N.O.)	
	S4	Multi-function input 4 (Fault reset)	
	S5	Multi-function input 5 (Multi setpoint 1)	
	S6	Multi-function input 6 (HAND mode)	
	S7	Multi-function input 7 (HAND mode 2)	
	S8	Multi-function input 8 (Through mode)	
	SC	Multi-function input common	
	SP	Digital input power supply +24 Vdc	24 Vdc power supply for digital inputs, 150 mA max
	SN	Digital input power supply 0 V 24 V transducer power supply 0 V	NOTICE: Do not jumper or short terminals SP and SN. Failure to comply will damage the drive.
Analog Inputs / Pulse Train Input	RP	Multi-function pulse train input (Frequency reference)	<ul style="list-style-type: none"> • Input frequency range: 0 to 32 kHz • Signal Duty Cycle: 30 to 70% • High level: 3.5 to 13.2 Vdc, low level: 0.0 to 0.8 Vdc • Input impedance: 3 kΩ
	+V	Power supply for analog inputs	10.5 Vdc (max allowable current 20 mA)
	24 V	+24 Vdc transducer power supply for customer use	150 mA maximum capacity
	A1	Multi-function analog input 1 (Frequency reference bias)	<ul style="list-style-type: none"> • -10 to 10 Vdc, 0 to 10 Vdc (input impedance: 20 kΩ) • 4 to 20 mA, 0 to 20 mA (input impedance: 250 Ω) • Voltage or current input must be selected by jumper S1 and H3-01.
	A2	Multi-function analog input 2 (PID feedback)	<ul style="list-style-type: none"> • -10 to 10 Vdc, 0 to 10 Vdc (input impedance: 20 kΩ) • 4 to 20 mA, 0 to 20 mA (input impedance: 250 Ω) • Voltage or current input must be selected by jumper S1 and H3-09.
	A3	Multi-function analog input 3 (HAND frequency reference)	<ul style="list-style-type: none"> • -10 to 10 Vdc, 0 to 10 Vdc (input impedance: 20 kΩ) • 4 to 20 mA, 0 to 20 mA (input impedance: 250 Ω) • Voltage or current input must be selected by jumper S1 and H3-05.
	AC	Frequency reference common	0 V
	E (G)	Ground for shielded lines and option cards	—

Output Terminals

Table i.8 lists the output terminals on the drive. Text in parenthesis indicates the default setting for each multi-function output.

Table i.8 Control Circuit Output Terminals

Type	No.	Terminal Name (Function)	Function (Signal Level) Default Setting
Fault Relay Output	MA	N.O.	30 Vdc, 10 mA to 1 A; 250 Vac, 10 mA to 1 A Minimum load: 5 Vdc, 10 mA
	MB	N.C. output	
	MC	Fault output common	

Type	No.	Terminal Name (Function)	Function (Signal Level) Default Setting
Multi-Function Digital Output </>	MD	N.O.	30 Vdc, 10 mA to 1 A; 250 Vac, 10 mA to 1 A Minimum load: 5 Vdc, 10 mA
	ME	N.C. Output	
	MF	Common (Speed agree)	
	M1	Multi-function digital output (During frequency output)	30 Vdc, 10 mA to 1 A; 250 Vac, 10 mA to 1 A Minimum load: 5 Vdc, 10 mA
	M2		
	M3		
	M4		
Monitor Output	FM	Analog monitor output 1 (Output frequency)	-10 to +10 Vdc, or 0 to +10 Vdc
	AM	Analog monitor output 2 (Output current)	
	AC	Monitor common	0 V

<1> Refrain from assigning functions to digital relay outputs that involve frequent switching, as doing so may shorten relay performance life. Switching life is estimated at 200,000 times (assumes 1 A, resistive load).

Serial Communication Terminals

Table i.9 Control Circuit Terminals: Serial Communications

Type	No.	Signal Name	Function (Signal Level)
MEMOBUS/Modbus Communication </>	R+	Communications input (+)	MEMOBUS/Modbus communication: Use an RS-422 or RS-485 cable to connect the drive. RS-422/RS-485 MEMOBUS/Modbus communication protocol 115.2 kbps (max.)
	R-	Communications input (-)	
	S+	Communications output (+)	
	S-	Communications output (-)	
	IG	Shield ground	0 V

<1> Enable the termination resistor in the last drive in a MEMOBUS/Modbus network by setting DIP switch S2 to the ON position. Refer to the manual section on **Control I/O Connections** for more information.

Terminal Configuration

The control circuit terminals are arranged as shown in **Figure i.20**.

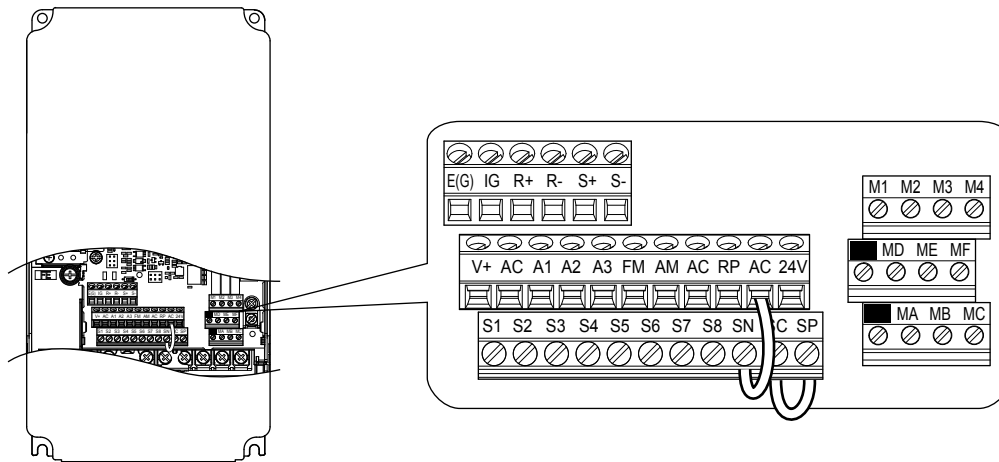

Figure i.20 Control Circuit Terminal Arrangement

i.4 Electrical Installation

■ Wire Size and Torque Specifications

Select appropriate wire type and gauges from [Table i.10](#). For simpler and more reliable wiring, use crimp ferrules on the wire ends.

Table i.10 Wire Gauges

Terminal	Screw Size	Tightening Torque N•m (lb. in)	Bare Wire Terminal		Ferrule-Type Terminal		Wire Type
			Applicable wire size mm ² (AWG)	Recomm. wire size mm ² (AWG)	Applicable wire size mm ² (AWG)	Recomm. wire size mm ² (AWG)	
S1-S8, SC, SN, SP	M3	0.5 to 0.6 (4.4 to 5.3)	Stranded wire: 0.2 to 1.0 (24 to 16) Solid wire: 0.2 to 1.5 (24 to 16)	0.75 (18)	0.25 to 0.5 (24 to 20)	0.5 (20)	Shielded wire, etc.
RP, V+, A1, A2, A3, AC, 24 V							
MA, MB, MC, MD, ME, MF							
M1-M4							
FM, AM, AC							
R+, R-, S+, S-, IG							

◆ Wiring the Control Circuit Terminal

This section describes the proper procedures and preparations for wiring the control terminals.

WARNING! *Electrical Shock Hazard. Do not remove covers or touch the circuit boards while the power is on. Failure to comply could result in death or serious injury.*

NOTICE: *Separate control circuit wiring from main circuit wiring (terminals R/L1, S/L2, T/L3, B1, B2, U/T1, V/T2, W/T3, \ominus , $\oplus 1$, $\oplus 2$) and other high-power lines. Improper wiring practices could result in drive malfunction due to electrical interference.*

NOTICE: *Separate wiring for digital output terminals MA, MB, MC, MD, ME, MF and M1 to M4 from wiring to other control circuit lines. Improper wiring practices could result in drive or equipment malfunction or nuisance trips.*

NOTICE: *Use a class 2 power supply when connecting to the control terminals. Improper application of peripheral devices could result in drive performance degradation due to improper power supply. Refer to NEC Article 725 Class 1, Class 2, and Class 3 Remote-Control, Signaling, and Power Limited Circuits for requirements concerning class 2 power supplies.*

NOTICE: *Insulate shields with tape or shrink tubing to prevent contact with other signal lines and equipment. Improper wiring practices could result in drive or equipment malfunction due to short circuit.*

NOTICE: *Connect the shield of shielded cable to the appropriate ground terminal. Improper equipment grounding could result in drive or equipment malfunction or nuisance trips.*

NOTICE: *Do not tighten screws beyond the specified tightening torque. Failure to comply may result in erroneous operation, damage to the terminal block, or cause a fire.*

NOTICE: *Use shielded twisted-pair cables as indicated to prevent operating faults. Improper wiring practices could result in drive or equipment malfunction due to electrical interference.*

Wire the control circuit only after terminals have been properly grounded and main circuit wiring is complete. [Refer to Terminal Board Wiring Guide on page 39](#) for details. Prepare the ends of the control circuit wiring as shown in [Figure i.23](#). [Refer to Wire Gauges on page 38](#).

Connect control wires as shown in [Figure i.21](#) and [Figure i.22](#).

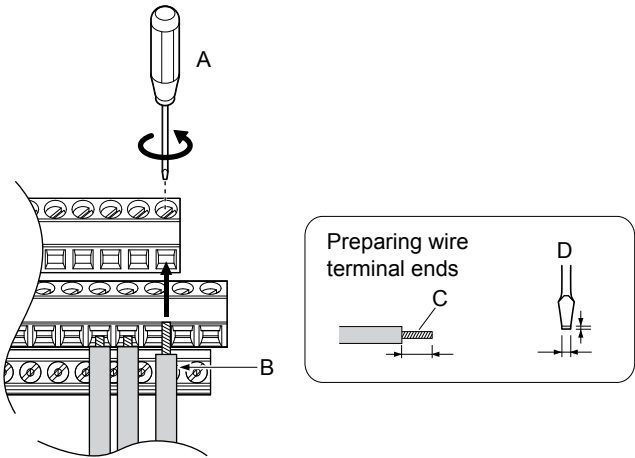

A – Loosen screw to insert wire.
 B – Single wire or stranded wire

C – Avoid fraying wire strands when stripping insulation from wire. Strip length 5.5 mm.
 D – Blade depth of 0.4 mm or less
 Blade width of 2.5 mm or less

Figure i.21 Terminal Board Wiring Guide

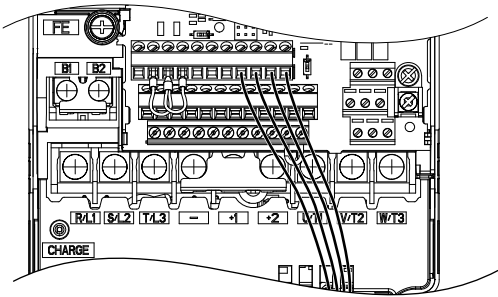
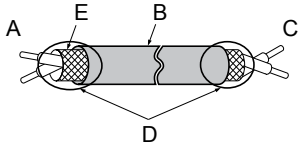

Figure i.22 Terminal Board Location Inside the Drive

When setting the frequency by analog reference from an external potentiometer, use shielded twisted-pair wires (preparing wire ends as shown in [Figure i.23](#)) and connect the shield to the ground terminal of the drive.



A – Drive side
 B – Insulation
 C – Control device side
 D – Shield sheath (insulate with tape)
 E – Shield

Figure i.23 Preparing the Ends of Shielded Cables

NOTICE: The analog signal wiring between the drive and the operator station or peripheral equipment should not exceed 50 meters when using an analog signal from a remote source to supply the frequency reference. Failure to comply could result in poor system performance.

◆ Sinking/Sourcing Mode for Digital Inputs

Use the wire jumper between terminals SC and SP or SC and SN to select between Sink mode, Source mode or external power supply for the digital inputs S1 to S8 as shown in [Table i.11](#) (Default: Sink mode, internal power supply).

NOTICE: Do not short terminals SP and SN. Failure to comply will damage the drive.

Table i.11 Digital Input Sink/Source/External Power Supply Selection

Mode	Drive Internal Power Supply (Terminals SN and SP)	External 24 Vdc Power Supply
Sinking Mode (NPN)		
Sourcing Mode (PNP)		

◆ Terminals A1, A2, and A3 Input Signal Selection

Terminals A1, A2, and A3 can be used to input either a voltage or a current signal. Select the signal type using jumper S1 as explained in [Table i.12](#). Set parameters H3-01, H3-05, and H3-09 accordingly as shown in [Table i.13](#).

Note: If terminals A1 and A2 are both set for frequency bias (H3-02 = 0 and H3-10 = 0), both input values will be combined to create the frequency reference.

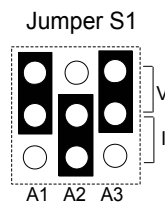

Figure i.24 Terminal A2 Set to Current Input; A1 and A3 Set to Voltage Input

Table i.12 Jumper S1 Settings

Setting	Description
V (top position)	Voltage input (-10 to +10 V or 0 to 10 V)
I (bottom position)	Current input (4 to 20 mA or 0 to 20 mA)

Table i.13 Voltage/Current Selection Parameter Details

No.	Parameter Name	Description	Setting Range	Default Setting
H3-01	Terminal A1 signal level selection	Selects the signal level for terminal A1. 0: 0 to 10 Vdc 1: 0 to 10 Vdc Bipolar 2: 4 to 20 mA 3: 0 to 20 mA	0 to 3	0
H3-05	Terminal A3 signal level selection	Selects the signal level for terminal A3. 0: 0 to 10 Vdc 1: 0 to 10 Vdc Bipolar 2: 4 to 20 mA 3: 0 to 20 mA	0 to 3	0
H3-09	Terminal A2 signal level selection	Selects the signal level for terminal A2. 0: 0 to 10 Vdc 1: 0 to 10 Vdc Bipolar 2: 4 to 20 mA 3: 0 to 20 mA	0 to 3	2

■ Transducer Wiring

Simplex Pump System - Transducer Connection using Analog Input A2 (4 to 20 mA Mode)

A2 used for pressure transducer. Example of retrofit application where an external power supply is used.

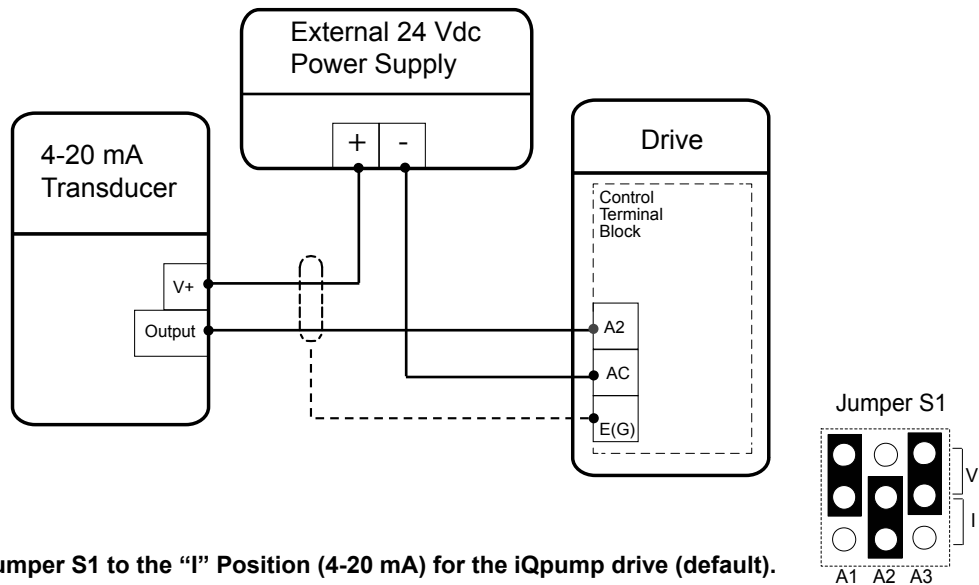

A2 used for pressure transducer. Example of new application where internal power supply is used

(2-Wire Transducer)

Example:
Customer supplied pressure transducer feedback device

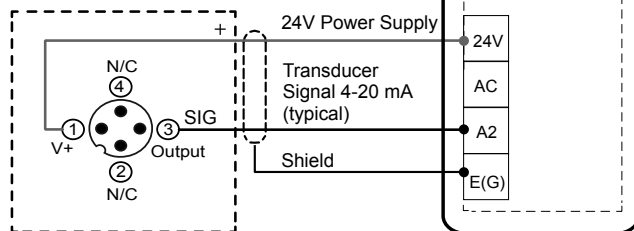

(3-Wire Transducer)

Example:
Customer supplied pressure transducer feedback device

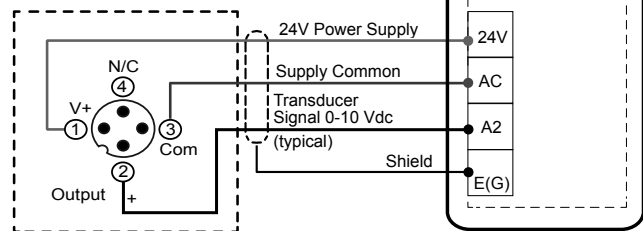

i.4 Electrical Installation

Duplex System: Single Transducer Connection using Analog Input A2

A2 used for pressure transducer.

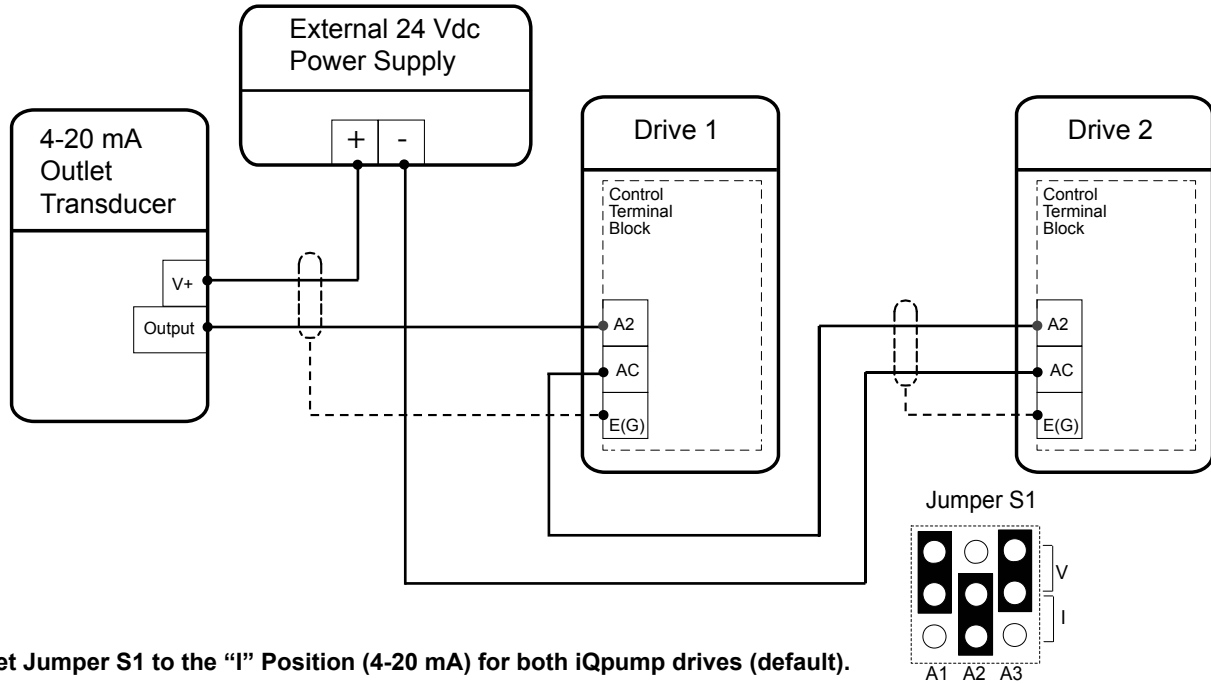

Triplex System: Transducer Connection using Analog Input A2

A2 used for water level or suction pressure transducer.

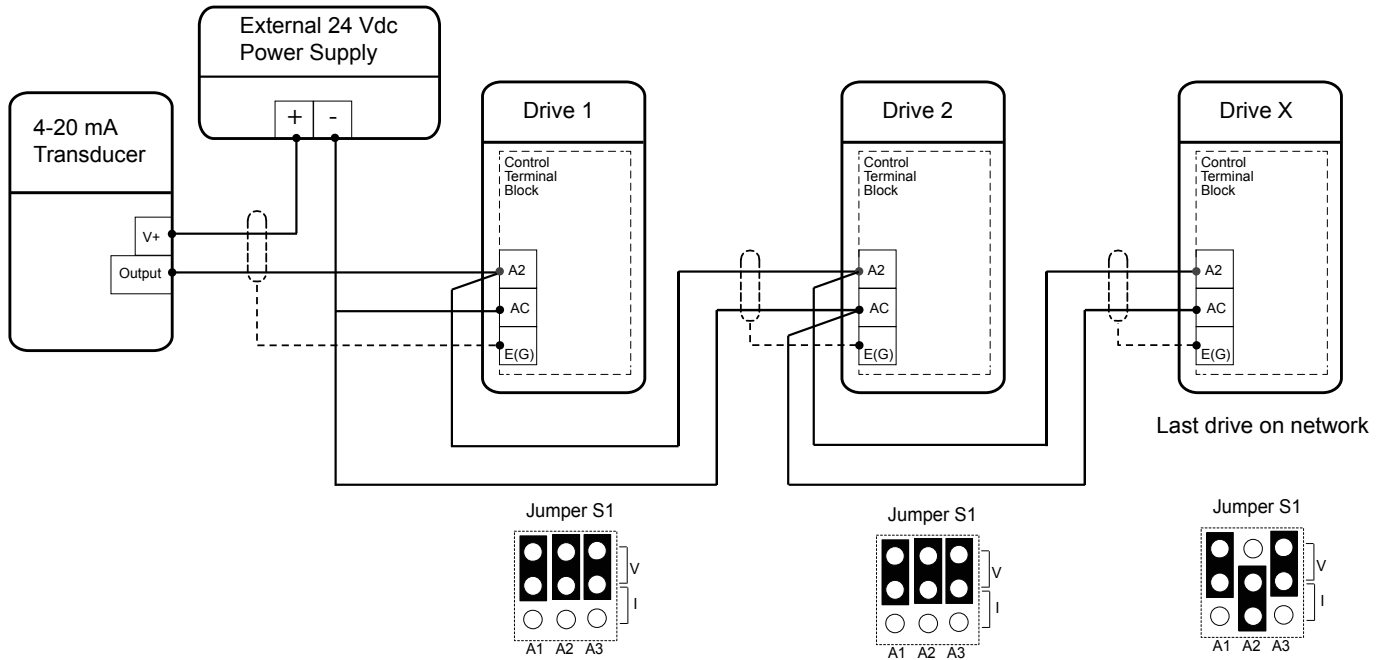

◆ Terminal AM/FM Signal Selection

The signal type for terminals AM and FM can be set to either voltage or current output using jumper S5 on the terminal board as explained in [Table i.14](#). When changing the setting of jumper S5, parameters H4-07 and H4-08 must be set accordingly. The default selection is voltage output for both terminals.

Table i.14 Jumper S5 Settings





Terminal	Voltage Output	Current Output
Terminal AM		
Terminal FM		

Table i.15 Parameter H4-07 and H4-08 Details

No.	Parameter Name	Description	Setting Range	Default Setting
H4-07	Terminal FM signal level selection	0: 0 to 10 Vdc 1: -10 to 10 Vdc	0 to 2	0
H4-08	Terminal AM signal level selection	2: 4 to 20 mA		

i.5 Start-Up Programming and Operation

◆ Setting the Real Time Clock

The time and date must be set when a new HOA keypad is plugged in and the drive is powered up. The HOA keypad will display the time and date setup screen for 30 seconds. If a button is not pressed during this time, the display will clear and a “Clock Not Set” alarm will flash. Pressing the F2 (Data) key will display the setting screen again.

■ Feedback Loss Wire Break Alarm

If there is no sensor wired to the drive, a “Feedback Loss – Wire Break” alarm will flash on the display. Providing the proper feedback device signal will clear the Feedback Loss alarm.

The drive requires a feedback device (e.g., pressure transducer, flow meter, etc.) to perform automatic system regulation. Any analog 0~10 V or 4-20 mA feedback device can be used in combination with the drive.

Note: The factory default setting for the drive is 4~20 mA feedback device connected to analog input A2.

■ Real Time Clock Setting Display

Note: Setting the Real-Time Clock will clear a “Clock Not Set” alarm.

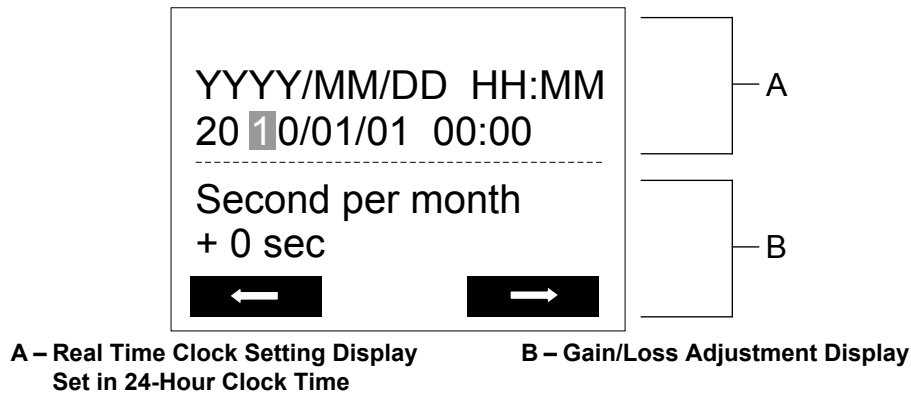

Figure i.25 Real Time Clock Adjustment Display

Display	Description
YYYY	Set the year with the last two digits.
MM	Set the month with two digits.
DD	Set the day with two digits.
HH:MM	Set the hours and minutes, with two digits for each. Note: Set in 24-hour clock time. After initial setup, the time will display in 12-hour clock time.
Second per month	Set the gain or loss in seconds per month. Note: This does not need to be set for the RTC to function properly.

Moving the Cursor

Pressing the F2 key or the RESET key will move the cursor to the digit on the right. Pressing the F1 key will move the cursor to the left.

Changing Settings

- **Changing YYYY/MM/DD HH:MM:** Pressing the up arrow key will increase the number selected by the cursor from 0 to 9. Pressing the down arrow key will decrease the number selected by the cursor from 0 to 9.
- **Setting the Seconds per Month:** *This setting does not need to be adjusted.* Pressing the up arrow key will increase the number selected by the cursor from -504 to +488 in increments of 8. Pressing the down arrow key will decrease the number selected by the cursor from -504 to +488 in increments of 8.

The feature is used to keep the RTC in sync with an external device clock, like a PLC or BAS system, and will adjust the clock by a set amount of seconds every month.

■ Real-Time Clock Setting at Initial Power-up of a New Drive

Setting the Real-time clock is required at power-up of a new HOA operator or after digital operator battery replacement.

Table i.16 illustrates how to set the Real-Time Clock at initial power-up of a new drive.

Table i.16 Clock Adjustment Procedure at Power-up of a New Drive

Procedure		Display
1	Turn the power on. The Real Time Clock Adjustment Display will appear. Use the right arrow key to select the desired digit, then set the correct date and 24-hour clock time using the up and down arrow keys.	
2	After entering the Real-Time Clock data, press the ENTER key to save the changes. The display will indicate “Entry Accepted” and return to the initial display in step 3 and the alarm LED will be OFF.	
3	Initial display.	

Manual Clock Adjustment by Setting o4-17 to 1

The following actions are possible in the Clock Adjustment Mode:

- Set the current time
- Check the time set to the drive Real-Time Clock

Table i.17 illustrates how to set the Real-Time Clock manually.

Table i.17 Manual Clock Adjustment Procedure by Setting o4-17 to 1

Procedure		Display
1	The “Clock Not Set” display will appear if the Real-Time Clock data is not entered within 30 seconds of power-up of a drive with an HOA operator that has not yet been set.	
2	Use the up and down arrow keys to scroll through display menu until the screen shows “Programming”.	
3	Press the ENTER key to enter select the parameter setting mode.	
4	Use the up and down arrow keys to scroll through display menu until parameter o4-17 appears.	

i.5 Start-Up Programming and Operation

Procedure		Display
5	Press the ENTER key until "0" flashes.	
6	Press the up arrow key so that the display changes to "1".	
7	Press the ENTER key and the time setting screen will appear. Use the right arrow key to select the desired digit, then set the correct date and time using the up and down arrow keys.	
8	After entering the correct time, press the ENTER key to save the changes. The display will return to the display shown in step 5 and the alarm LED will be OFF.	

■ o4-17: Real-Time Clock Setting (Resetting RTC to Factory Default)

No. (Addr. Hex)	Name	Description	Values
o4-17 (3100)	Set/Reset Real-time Clock	Sets the current date and time for the Real-Time Clock. 0: — — No Setting 1: Real-Time Clock Set 2: Real-Time Clock Reset	Default: 0 Range: 0 to 2

Setting 0: — —

No Setting (Default)

Setting 1: Set

The digital operator will show the Clock Adjustment display. In Clock Adjustment Mode the user can adjust the Real-Time Clock.

Setting 2: Reset

The Real-Time Clock data is cleared. A Clock Not Set alarm will occur until o4-17 is set to 1 and the Real-Time Clock is set.

◆ HOA Keypad Keys and Displays

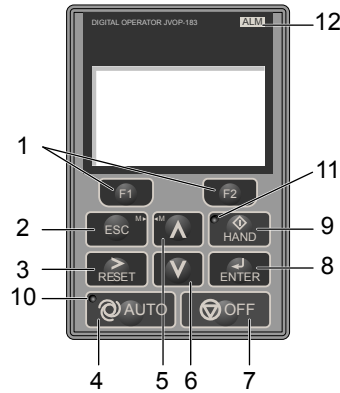

Figure i.26 Keys and Displays on the HOA Keypad

No.	Display	Name	Function
1		Function Key (F1, F2)	The functions assigned to F1 and F2 vary depending on the currently displayed menu. The name of each function appears in the lower half of the display window.
2		ESC Key	<ul style="list-style-type: none"> Returns to the previous display. Moves the cursor one space to the left. Pressing and holding this button will return to the Frequency Reference display.
3		RESET Key	<ul style="list-style-type: none"> Moves the cursor to the right. Resets the drive to clear a fault situation.
4		AUTO Key	<p>Selects the source of Run command and frequency reference.</p> <ul style="list-style-type: none"> Set the drive to AUTO mode. Run command input source depends on b1-02. Frequency reference input source depends on b1-01.
5		Up Arrow Key	Scrolls up to display the next item, selects parameter numbers, and increments setting values.
6		Down Arrow Key	Scrolls down to display the previous item, selects parameter numbers, and decrements setting values.
7		OFF Key	<p>Follows the stopping method set in b1-03 to stop drive operation.</p> <p>Note: The OFF key is DISABLED during Emergency Override.</p>
8		ENTER Key	<ul style="list-style-type: none"> Enters parameter values and settings. Selects a menu item to move between displays.
9		HAND Key	<p>The drive runs at a selectable frequency reference source as set by P5-01.</p> <ul style="list-style-type: none"> Set the drive to HAND mode. When P5-03 is set to 1, HAND and AUTO mode can be switched while the drive is running.
10		AUTO Light	Lit while the drive is in AUTO mode.
11		HAND Light	Lit while the drive is in HAND mode.
12		ALM LED Light	Lit when the drive detects an alarm or error.

◆ LCD Display

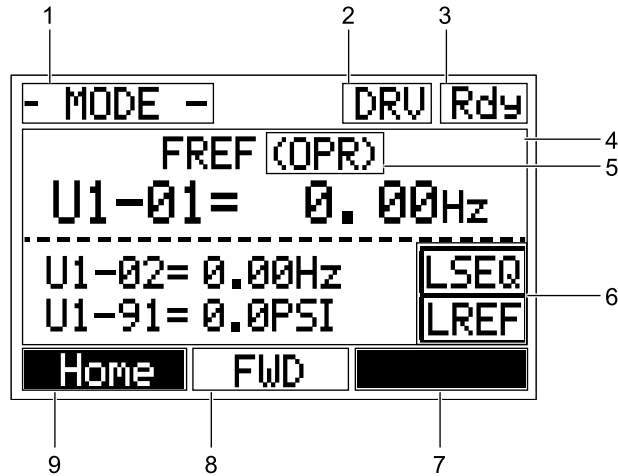







Figure i.27 LCD Display

Table i.18 Display and Contents

No.	Name	Display	Content
1	Operation Mode Menus	MODE	Displayed when in Mode Selection.
		QMONI: Use F1/F2	Instructions to access the Quick Monitors.
		MENU: Use UP/DWN	Instructions to access the next menu item.
		MONITR	Displayed when in Monitor Mode.
		VERIFY	Indicates the Verify Menu.
		PRMSET	Displayed when in Parameter Setting Mode.
		A.TUNE	Displayed during Auto-Tuning.
2	Mode Display Area	DRV	Displayed when in Drive Mode.
		PRG	Displayed when in Programming Mode.
3	Ready	Rdy	Indicates the drive is ready to run.
4	Data Display	—	Displays specific data and operation data.
5	Frequency Reference Assignment </>	OPR	Displayed when the frequency reference is assigned to the HOA keypad.
		COM	Displayed when the frequency reference is assigned to the MEMOBUS/Modbus Communication Inputs of the drive.
		OP	Displayed when the frequency reference is assigned to option card connected to the drive.
		AI	Displayed when the function reference is assigned to an analog input.
		OFF	Displayed when HAND mode is OFF.
6	LOCAL/REMOTE Display </>	RSEQ	Displayed when the Run command is supplied from a remote source. Note: This display will blink when b1-02 is set to 1 (Digital Inputs).
		LSEQ	Displayed when the Run command is supplied from the HOA keypad.
		RREF	Displayed when the Run command is supplied from a remote source. Note: This display will blink when b1-01 is set to 1 (Analog Inputs).
		LREF	Displayed when the Run command is supplied from the HOA keypad.
7	Function Key 2 (F2)	<-MONITOR->	Pressing displays the next Quick Monitor.
		DATA	Pressing scrolls to the next display.
		→	Pressing scrolls the cursor to the right.
		RESET	Pressing resets the existing drive fault error.
		Monitor	Pressing switches Monitor mode.

No.	Name	Display	Content
8	FWD/REV	FWD	Indicates forward motor operation.
		REV	Indicates reverse motor operation.
9	Function Key 1 (F1)	<-MONITOR->	Pressing  displays the next Quick Monitor.
		←	Pressing  scrolls the cursor to the left.
		Home	Pressing  returns to the top menu (Frequency Reference).
		ESC	Pressing  returns to the previous display.
		Monitor	Pressing  switches Monitor mode.

<1> Displayed when in Frequency Reference Mode.

<2> Displayed when in Frequency Reference Mode and Monitor Mode.

◆ ALARM (ALM) LED Displays

Table i.19 ALARM (ALM) LED Status and Contents

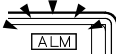
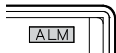
State	Content	Display
Illuminated	When the drive detects an alarm or error.	
Flashing	<ul style="list-style-type: none"> When an alarm occurs. When an oPE is detected. When a fault or error occurs during Auto-Tuning. 	
Off	Normal operation (no fault or alarm).	

◆ Menu Structure for HOA Keypad

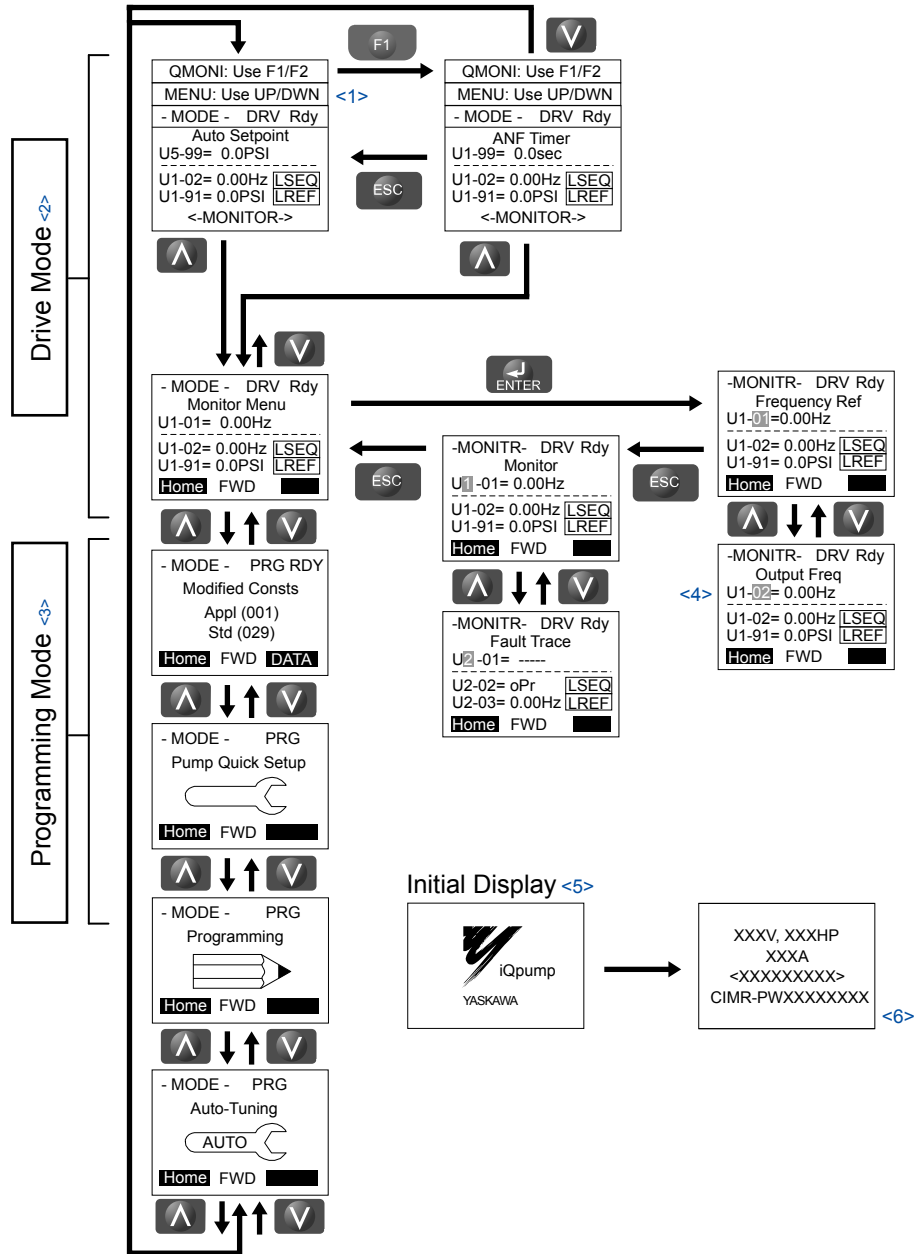

Figure i.28 HOA Keypad Menu and Screen Structure

- <1> The display cycles between these three displays on the initial startup screen and the Quick Monitor screens.
- <2> Pressing “AUTO” or “HAND” will start the motor.
- <3> Drive cannot operate motor.
- <4> Flashing characters are shown with white letters on gray background. (Example: **0**)
- <5> The Frequency Reference appears after the initial display that shows the product name.
- <6> The information that appears on the display will vary depending on the drive model.

◆ Powering Up the Drive

Review the following table before applying power.

Item to Check	Description
Power supply voltage	200 V class: Three-phase/Single-phase 200 to 240 Vac 50/60 Hz 400 V class: Three-phase/Single-phase 380 to 480 Vac 50/60 Hz 600 V class: Three-phase/Single-phase 500 to 600 Vac 50/60 Hz
	Properly wire the power supply input terminals (R/L1, S/L2, T/L3). </>
	Check for proper grounding of drive and motor.
Drive output terminals and motor terminals	Properly wire drive output terminals U/T1, V/T2, and W/T3 with motor terminals U, V, and W.
Control circuit terminals	Check control circuit terminal connections.
Drive control terminal status	Open all control circuit terminals (off).
Status of the load and connected machinery	Decouple the motor from the load.

<1> Confirm the following when connecting models 4A0930 and 4A1200: Remove the jumpers on R1/L11, S1/L21, and T1/L31 when using 12-phase rectification. When operating without 12-phase rectification, properly wire terminals R1/L11, S1/L21, and T1/L31 in addition to terminals R/L1, S/L2, and T/L3.

◆ Basic Drive Setup Adjustments

■ A1-01: Access Level Selection

Allows or restricts access to drive parameters.

No.	Parameter Name	Setting Range	Default
A1-01	Access Level Selection	0 to 3	2

Setting 0: Operation only

Access to only parameters A1-01, A1-04, and all U monitor parameters.

Setting 1: User Parameters

Access to only a specific list of parameters set to A2-01 through A2-32. These User Parameters can be accessed using the Setup Mode of the digital operator.

Setting 2: Advanced Access Level (A) and Setup Access Level (S)

All parameters can be viewed and edited.

Setting 3: Lock Parameters

Parameters that are normally visible in the advanced access level (A1-01 = 2) are still visible, but the only parameters that can be changed are A1-01 and A1-04.

The Auto Tuning and Pump Quick Setup menus will not be displayed.

■ A1-03: Initialize Parameters

Resets parameters to default values or performs an Application Preset for fan or pump applications. After initialization, the setting for A1-03 automatically returns to 0.

No.	Parameter Name	Setting Range	Default
A1-03	Initialize Parameters	0, 1110, 2220, 3330, 5550, 6008, 6009, 6010, 6011, 6012, 6013, 6014, 6015, 6016, 7770, 7771	0

- Note:**
1. A1-03 is initially set to "6008" from the factory, although the keypad will always display "0".
 2. Settings 6012 and 6013 are available in drive software versions PRG: 8552 and later and are not available in drive models 4A0930 and 4A1200.
 3. Setting 6014 is available in drive software versions PRG: 8553 and later and is not available in drive models 4A0930 and 4A1200.
 4. Settings 6015 and 6016 are available in drive software versions PRG: 8556 and later and are not available in drive models 4A0930 and 4A1200.

i.5 Start-Up Programming and Operation

Setting 1110: User Initialize

Resets parameters to the values selected by the user as User Settings. User Settings are stored when parameter o2-03 is set to “1: Set defaults”.

Note: User Initialization resets all parameters to a user-defined set of default values previously saved to the drive. Set parameter o2-03 to 2 to clear the user-defined default values.

Setting 2220: 2-Wire Initialization

Resets parameters to default settings with digital inputs S1 and S2 configured as Forward run and Reverse run, respectively.

Setting 3330: 3-Wire Initialization

Resets parameters to default settings with digital inputs S1, S2, and S5 configured as Run, Stop, and Forward/Reverse respectively.

Setting 5550: Terminal/Control Initialize

An oPE04 error appears on the digital operator when a terminal block with settings saved to its built-in memory is installed in a drive that has edited parameters. Set A1-03 to 5550 to use the parameter settings saved to the terminal block memory.

Application Presets are available to facilitate drive setup for commonly used applications. Selecting one of these Application Presets automatically assigns functions to the input and output terminals and sets a predefined group of parameters to values appropriate for the selected application.

In addition, the parameters most likely to be changed are assigned to the group of User Parameters, A2-01 through A2-16. User Parameters are part of the Setup Group, which provides quicker access by eliminating the need to scroll through multiple menus.

Setting 6008: Pressure Control

Application Preset for Pressure Control applications.

Setting 6009: Pump Down Level

Application Preset for Pump Down Level applications.

Setting 6010: Geothermal Mode

Application Preset for Geothermal Mode.

Setting 6011: VTC Pressure Mode

Application Preset for VTC Pressure Mode.

Setting 6012: Pivot Panel VTC

Application Preset for Pivot Panel VTC.

- Note:**
1. This setting is available in drive software versions PRG: 8552 and later.
 2. This setting is not available in drive models 4A0930 and 4A1200.

Setting 6013: Advanced Pressure Control

Application Preset for Advanced Pressure Control.

- Note:**
1. This setting is available in drive software versions PRG: 8552 and later.
 2. This setting is not available in drive models 4A0930 and 4A1200.

Setting 6014: Pivot Panel Submersible

Application Preset for Pivot Panel Submersible Control.

- Note:**
1. This setting is available in drive software versions PRG: 8553 and later.
 2. This setting is not available in drive models 4A0930 and 4A1200.

Setting 6015: VTC Pump Command

Application Preset for VTC Pump Command.

- Note:**
1. This setting is available in drive software versions PRG: 8556 and later.
 2. This setting is not available in drive models 4A0930 and 4A1200.

Setting 6016: Sub Pump Command

Application Preset for Sub Pump Command.

- Note:**
1. This setting is available in drive software versions PRG: 8556 and later.
 2. This setting is not available in drive models 4A0930 and 4A1200.

Setting 7770: General Purpose

General Purpose Application Preset.

Setting 7771: Submersible Motor General Purpose Operation

General Purpose Application Preset.

■ **b1-01: Frequency Reference Selection 1**

Selects the frequency reference source 1 for the REMOTE mode.

Note: If a Run command is input to the drive but the frequency reference entered is 0 or below the minimum frequency, the RUN indicator LED on the digital operator will light and the STOP indicator will flash.

No.	Parameter Name	Setting Range	Default
b1-01	Frequency Reference Selection 1	0 to 5	0

In order to run the drive and motor, the drive must receive a Run command and an Auto Setpoint command. Parameter b1-01 specifies the origin of the Auto setpoint when in AUTO Mode. Switch to AUTO mode by pressing the AUTO button on the HOA keypad while the drive is stopped.

Note: If a Run command is input to the drive without a corresponding Auto setpoint, the Run indicator on the HOA keypad will turn on and the STOP indicator on the keypad will blink.

If the drive should follow the “HAND Reference” set by the HOA keypad, use HAND Mode by pressing the HAND key and set P5-01 to “1: Hand Reference (P5-02).” The HAND reference can then be entered into the U1-01 monitor parameter in the “-DRIVE-” Menu.

The drive offers the ability to provide four types of “Auto Setpoint” reference sources. These Auto Setpoint reference sources are determined by the setting of b1-01 and the drive set to AUTO Mode by pressing the AUTO key on the keypad.

Prior to programming, it is recommended to select the system units (P1-02) and the feedback device, Scaling (P1- 03) first. P1-03 will automatically scale the drive setpoint.

Example: P1-02 = 1: PSI

P1-03 = 200, feedback range = 200 PSI.

If the drive should follow an “Auto Set-Point” set by the HOA keypad: Set b1-01 to “0: Operator” (factory default). The Auto setpoint can then be entered into the U1-01 monitor parameter in the “-DRIVE-” menu.

Setting 0: Operator (HOA keypad)

Using this setting, the frequency reference can be input by:

- switching between the multi-speed references in the d1-□□ parameters.
- entering the frequency reference on the operator keypad.

This selection will also switch PID setpoint to Q1-01.

Setting 1: Terminals (analog input terminals)

Using this setting, an analog frequency reference can be entered as a voltage or current signal from terminals A1, A2, or A3.

To set the drive to follow an “Auto Setpoint” set by the analog input, set b1-01 to 1 (Terminals) and connect a potentiometer or external signal to the drive.

Note: When b1-01 is set to 1 (Terminals) and P5-01 is set to 0 (HAND Mode Reference), the setpoint and the HAND reference are determined by the external analog signal.

Voltage Input

Voltage input can be used at any of the three analog input terminals. Make the settings as described in [Table i.20](#) for the input used.

Table i.20 Analog Input Settings for Frequency Reference Using Voltage Signals

Terminal	Signal Level	Parameter Settings				Notes
		Signal Level Selection	Function Selection	Gain	Bias	
A1	0 to 10 Vdc	H3-01 = 0	H3-02 = 0 (Frequency Reference Bias)	H3-03	H3-04	-
	0 to 10 Vdc Bipolar	H3-01 = 1				

i.5 Start-Up Programming and Operation

Terminal	Signal Level	Parameter Settings				Notes
		Signal Level Selection	Function Selection	Gain	Bias	
A2	0 to 10 Vdc	H3-09 = 0	H3-10 = 0 (Frequency Reference Bias)	H3-11	H3-12	Set jumper S1 on the terminal board to "V" for voltage input.
	0 to 10 Vdc Bipolar	H3-09 = 1				
A3	0 to 10 Vdc	H3-05 = 0	H3-06 = 0 (Frequency Reference Bias)	H3-07	H3-08	Set DIP switch S4 on the terminal board to "AI".
	0 to 10 Vdc Bipolar	H3-05 = 1				

Current Input

Input terminals, A1, A2, and A3 can accept a current input signal. Refer to [Table i.21](#) for an example to set terminal A2 for current input.

Table i.21 Analog Input Settings for Frequency Reference Using a Current Signal

Terminal	Signal Level	Parameter Settings				Notes
		Signal Level Selection	Function Selection	Gain	Bias	
A2	4 to 20 mA	H3-09 = 2	H3-10 = 0 (Frequency Bias)	H3-11	H3-12	Make sure to set jumper S1 on the terminal board to "I" for current input.
	0 to 20 mA	H3-09 = 3				

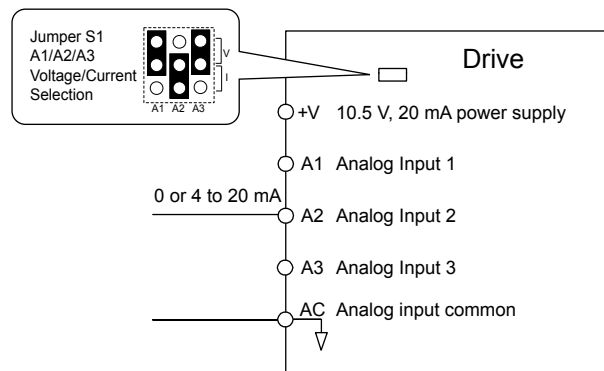

Figure i.29 Setting the Frequency Reference as a Current Signal to Terminal A2

Switching between Main/Auxiliary Frequency References

The frequency reference input can be switched between the analog terminals A1, A2, and A3 using multi-speed inputs. To use several speed references for a multi-step speed sequence, set the H1-□□ parameters to 3, 4, 5, and 32. To assign the Jog reference to a digital input, set H1-□□ to 6.

Setting 2: Serial Communications

This setting requires entering the frequency reference via the RS-485/422 serial communications port (control terminals R+, R-, S+, S-).

To setup the drive to receive the "Auto Setpoint" from serial communication, set b1-01 to "2: Serial Com," and connect the RS-422/RS-485 serial communications cable to terminals R+, R-, S+, and S- on the control I/O terminal block. Refer to [55](#) to see the connection diagram using a PC to provide the auto setpoint reference to the drive.

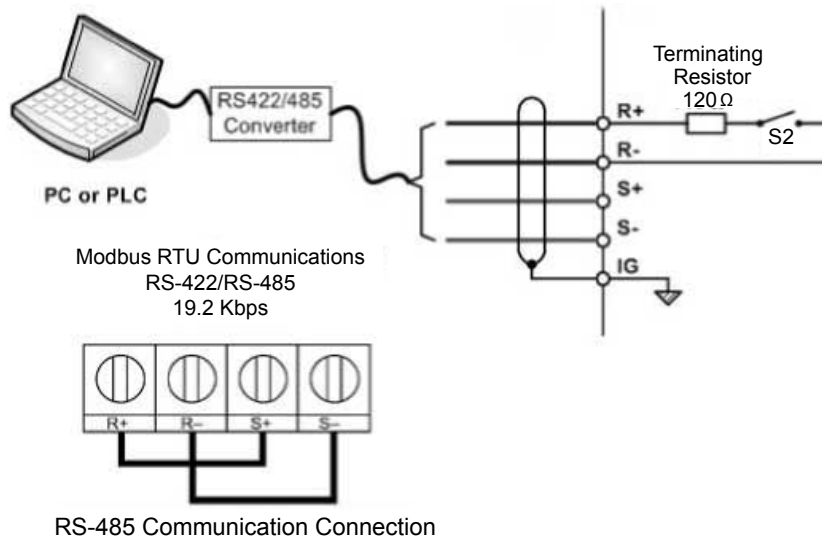

Figure i.30 PC or PLC Connection Diagram

Setting 3: Option card

This setting requires entering the frequency reference via an option board plugged into connector CN5-A on the drive control board. Consult the option board manual for instructions on integrating the drive with the communication system.

Note: If the frequency reference source is set for Option PCB (b1-01 = 3), but an option board is not installed, an oPE05 Operator Programming Error will be displayed on the digital operator and the drive will not run.

To setup the drive to receive the “Auto Setpoint” for a network communication option card, set b1-01 to “3: Option PCB”, and plug a supported communication option card into the drive control PCB. Consult the manual supplied with the option for instructions on integrating the drive into the network system.

Setting 4: Pulse Train Input

This setting requires a pulse train signal to terminal RP to provide the frequency reference. Follow the directions below to verify that the pulse signal is working properly.

Verifying the Pulse Train is Working Properly

- Set b1-04 to 4 and set H6-01 to 0.
- Set the H6-02 to the pulse train frequency value that equals 100% of the frequency reference.
- Enter a pulse train signal to terminal RP and check for the correct frequency reference on the display.

Setting 5: Geothermal Mode

■ b1-02: Run Command Selection 1

Determines the Run command source 1 in AUTO Mode.

The drive comes factory programmed for Start and Stop from the keypad, but the user can program the drive to receive a Run command from four different inputs: digital operator, terminals, serial communications, or an option PCB.

To set the drive to receive the Run command from the HOA keypad, set b1-02 to “0: Operator,” and the HAND key will be used to provide the Run command to the drive.

To set the drive to receive the Run command from the external terminals, set b1-02 to “1: Terminals” and initiate an external Run command by a contact closure between terminals S1 and SN.

Note: Using the external terminals requires setting the drive to AUTO Mode by pressing the AUTO key.

No.	Parameter Name	Setting Range	Default
b1-02	Run Command Selection 1	0 to 3; 6 to 8	0

- Note:**
1. Settings 6 to 8 are available in drive software versions PRG: 8552 and later.
 2. Settings 6 to 8 are not available in drive models 4A0930 and 4A1200.

Setting 0: Operator (HOA keypad)

This setting requires entering the Run command via the HOA keypad AUTO key and also illuminates the HAND indicator on the digital operator.

i.5 Start-Up Programming and Operation

Setting 1: Control Circuit Terminal

This setting requires entering the Run command via the digital input terminals using one of following sequences:

- 2-Wire sequence 1:

Two inputs (FWD/Stop-REV/Stop). Set A1-03 to 2220 to initialize the drive and preset terminals S1 and S2 to these functions. This is the default setting of the drive.

- 2-Wire sequence 2:

Two inputs (Start/Stop-FWD/REV).

- 3-Wire sequence:

Three inputs (Start-Stop-FWD/REV). Set A1-03 to 3330 to initialize the drive and preset terminals S1, S2, and S5 to these functions.

Setting 2: MEMOBUS/Modbus Communications

This setting requires entering the Run command via serial communications by connecting the RS-485/422 serial communication cable to control terminals R+, R-, S+, and S- on the removable terminal block.

Setting 3: Option Card

This setting requires entering the Run command via the communication option board by plugging a communication option board into the CN5-A port on the control PCB. Refer to the option board manual for instructions on integrating the drive into the communication system.

Note: If b1-02 is set to 3, but an option board is not installed in CN5-A, an oPE05 operator programming error will be displayed on the digital operator and the drive will not run.

Setting 6: AUTOKey + Term

When b1-02/b1-16 = 6, the AUTO key puts the drive into AUTO mode and the terminal programmed for Run (H1-□□ = 40, 41, or 42) acts as the External Run command.

Note: Available in drive software versions PRG: 8552 and later.

- Note:**
1. Setting available in drive software versions PRG: 8552 and later.
 2. Setting not available in drive models 4A0930 and 4A1200.

Setting 7: AUTOKey + Serial

When b1-02/b1-16 = 7, the AUTO key puts the drive into AUTO mode and the Serial Run command (register 0001) acts as the External Run command.

- Note:**
1. Setting available in drive software versions PRG: 8552 and later.
 2. Setting not available in drive models 4A0930 and 4A1200.

Setting 8: AUTOKey + Option

When b1-02/b1-16 = 8, the AUTO key puts the drive into AUTO mode and the Option Card Run command acts as the External Run command.

- Note:**
1. Setting available in drive software versions PRG: 8552 and later.
 2. Setting not available in drive models 4A0930 and 4A1200.

■ b1-03: Stopping Method Selection

Selects how the drive stops the motor when the Run command is removed or when a Stop command is entered.

Note: Parameter b1-11, Run Delay at Stop (Back Spin Timer), is effective for all stopping methods (b1-03 = 0 to 3), not only Coast to Stop w/ Timer (b1-03 =3).

No.	Parameter Name	Setting Range	Default
b1-03	Stopping Method Selection	0 to 3	1

Setting 0: Ramp to Stop

When the Run command is removed, the drive will decelerate the motor to stop. The deceleration rate is determined by the active deceleration time. The default deceleration time is set to parameter C1-02.

When the output frequency falls below the level set in parameter b2-01, the drive will start DC injection, Zero Speed Control, or Short Circuit Braking.

Setting 1: Coast to Stop

When the Run command is removed, the drive will shut off its output and the motor will coast (uncontrolled deceleration) to stop. The stopping time is determined by the inertia and the friction in the driven system.

Setting 2: DC Injection Braking to Stop

When the Run command is removed, the drive will enter baseblock (turn off its output) for the minimum baseblock time (L2-03). When the minimum baseblock time has expired, the drive will inject the amount DC Injection Braking is set in parameter b2-02 into the motor windings to brake the motor. The stopping time in DC Injection Braking to Stop is significantly faster compared to Coast to Stop.

DC Injection Braking time is determined by the value set to b2-04 and the output frequency at the time the Run command is removed. It can be calculated by:

Setting 3: Coast to Stop with Timer (Used for Back Spin Control on Vertical Turbine Pumps)

When the Run command is removed, the drive coasts to a stop. If parameter b1-11 is set to zero, the coast-timer (Run Delay at Stop) becomes a value determined by a combination of output frequency and the C1-02 parameter. However, if b1-11 is set greater than zero, the Run Delay at Stop timer is set to b1-11. If the Run command is re-issued during the Run Delay at Stop timer time, the drive WILL restart when the timer expires without the need to re-cycle the Run command. The Run Delay at Stop timer will operate for both AUTO Mode and HAND Mode. The Run Delay at Stop timer will still operate when the drive goes to sleep and then wakes up. During the Run Delay at Stop timer execution, the HOA keypad will display the alarm “WrUn”. Both Alarm and Run indicators will blink while the drive waits to execute the Run command.

The wait time t is determined by the output frequency when the Run command is removed and by the active deceleration time.

■ b3-01: Speed Search Selection at Start

Determines if Speed Search is automatically performed when a Run command is issued.

No.	Parameter Name	Setting Range	Default
b3-01	Speed Search Selection at Start	0, 1	0

Setting 0: Disabled

This setting starts operating the drive at the minimum output frequency when the Run command is entered. If external Speed Search 1 or 2 is already enabled by a digital input, the drive will start operating with Speed Search.

Setting 1: Enabled

This setting performs Speed Search when the Run command is entered. The drive begins running the motor after Speed Search is complete.

i.5 Start-Up Programming and Operation

■ b5-01: PID Function Setting

Enables and disables the PID operation and selects the PID operation mode.

No.	Parameter Name	Setting Range	Default
b5-01	PID Function Setting	0, 1	1

Setting 0: PID disabled

Setting 1: Output frequency = PID output 1

The PID controller is enabled and the PID output builds the frequency reference. The PID input is D controlled.

■ b5-02: Proportional Gain Setting (P)

Sets the P gain applied to the PID input. Larger values will tend to reduce the error but may cause oscillations if set too high, while lower values may allow too much offset between the setpoint and feedback. The function of b5-02 is disabled when P1-24 > 0.

No.	Name	Setting Range	Default
b5-02	Proportional Gain Setting (P)	0.00 to 25.00	2.00

■ b5-03: Integral Time Setting (I)

Sets the time constant used to calculate the integral of the PID input. The shorter the integral time set to b5-03, the faster the offset will be eliminated. If the integral time is set too short, however, overshoot or oscillation may occur. To turn off the integral time, set b5-03 to 0.00.

No.	Name	Setting Range	Default
b5-03	Integral Time Setting (I)	0.0 to 360.0 s	1.0 s

■ b5-09: PID Output Level Selection

Reverses the sign of the PID controller output signal. Normally a positive PID input (feedback smaller than setpoint) leads to positive PID output.

No.	Parameter Name	Setting Range	Default
b5-09	PID Output Level Selection	0, 1	0

Setting 0: Normal Output

A positive PID input causes an increase in the PID output (direct acting).

Setting 1: Reverse Output

A positive PID input causes a decrease in the PID output (reverse acting).

■ b5-39: PID Setpoint User Display, PID Setpoint Display Digits

Set a user-defined display for the PID setpoint (b5-19) and PID feedback monitors (U5-01, U5-04). The setting value is equal to the number of decimal places.

No.	Name	Setting Range	Default
b5-39	PID Setpoint Display Digits	0 to 3	1

Setting 0: No Decimal Places

Setting 1: One Decimal Place

Setting 2: Two Decimal Places

Setting 3: Three Decimal Places

■ C1-01 to C1-04: Accel, Decel Times 1 and 2

Two different sets of acceleration and deceleration times can be set in the drive by digital inputs, motor selection, or switched automatically.

Acceleration time parameters always set the time to accelerate from 0 Hz to the maximum output frequency (E1-04).

Deceleration time parameters always set the time to decelerate from maximum output frequency to 0 Hz. C1-01 and C1-02 are the default active accel/decel settings.

No.	Parameter Name	Setting Range	Default
C1-01	Acceleration Time 1	0.0 to 6000.0 s </>	10.0 s
C1-02	Deceleration Time 1		
C1-03	Acceleration Time 2		
C1-04	Deceleration Time 2		

<1> The setting range for the acceleration and deceleration times is determined by the accel/decel time setting units in C1-10. For example, if the time is set in units of 0.01 s (C1-10 = 0), the setting range becomes 0.00 to 600.00 s.

■ E2-01: Motor Rated Current

Provides motor control, protects the motor, and calculates torque limits. Set E2-01 to the full load amps (FLA) stamped on the motor nameplate. If Auto-Tuning completes successfully, the value entered to T1-04 will automatically be saved to E2-01.

No.	Parameter Name	Setting Range	Default
E2-01	Motor Rated Current	10% to 200% of the drive rated current </>	Determined by o2-04

<1> Display is in the following units:
 2A0004 to 2A0040, 4A0002 to 4A0023, and 5A0007 to 5A0017: 0.01 A units.
 2A0056 to 2A0415, 4A0031 to 4A0675, and 5A0022 to 5A0242: 0.1 A units.
 4A0930 and 4A1200: 1 A units.

Note: An oPE02 error will occur if E2-01 ≤ E2-03. Set E2-03 correctly to prevent this error.

■ E2-04: Number of Motor Poles

Set the number of motor poles to E2-04. If Auto-Tuning completes successfully, the value entered to T1-06 will automatically be saved to E2-04.

No.	Parameter Name	Setting Range	Default
E2-04	Number of Motor Poles	2 to 48	2

■ H1-01 to H1-08: Functions for Terminals S1 to S8

These parameters assign functions to the multi-function digital inputs. The various functions and settings are listed in [Table i.22](#).

No.	Parameter Name	Setting Range	Default
H1-01	Multi-Function Digital Input Terminal S1 Function Selection	1 to 9F	40 (F) </> : Forward Run Command (2-Wire sequence)
H1-02	Multi-Function Digital Input Terminal S2 Function Selection	1 to 9F	F: Through Mode
H1-03	Multi-Function Digital Input Terminal S3 Function Selection	0 to 9F	26: External Pump Fault
H1-04	Multi-Function Digital Input Terminal S4 Function Selection	0 to 9F	14: Fault Reset
H1-05	Multi-Function Digital Input Terminal S5 Function Selection	0 to 9F	8D (0) </> : Multi Setpoint 1
H1-06	Multi-Function Digital Input Terminal S6 Function Selection	0 to 9F	80 (3) </> : HAND Mode
H1-07	Multi-Function Digital Input Terminal S7 Function Selection	0 to 9F	81 (4) </> : HAND Mode 2
H1-08	Multi-Function Digital Input Terminal S8 Function Selection	0 to 9F	F (6) </> : Through Mode

<1> Number appearing in parenthesis is the default value after performing a 3-Wire initialization (A1-03 = 3330).

Table i.22 Multi-Function Digital Input Terminal Settings

Setting	Function	Page	Setting	Function	Page
0	3-Wire sequence	–	9	Baseblock command (N.C.)	–
2	External Reference 1/2 Selection	–	A	Accel/decel ramp hold	–
3	Multi-Step Speed Reference 1	–	B	Drive overheat alarm (oH2)	–
4	Multi-Step Speed Reference 2	–	C	Analog terminal input selection	–
5	Multi-Step Speed Reference 3	–	F	Through mode	–
6	Jog reference selection	–	10	Up command	–
7	Accel/decel time selection 1	–	11	Down command	–
8	Baseblock command (N.O.)	–	12	Forward Jog	–

i.5 Start-Up Programming and Operation

Setting	Function	Page
13	Reverse Jog	–
14	Fault reset	–
15	Fast Stop (N.O.)	–
17	Fast Stop (N.C.)	–
18	Timer function input	–
19	PID disable	–
1A	Accel/decel time selection 2	–
1B	Program lockout	–
1E	Reference sample hold	–
20 to 2F	Ext. pump fault	–
30	PID integral reset	–
31	PID integral hold	–
32	Multi-Step Speed Reference 4	–
34	PID soft starter cancel	–
35	PID input level selection	–
40	Forward run command (2-Wire sequence)	–
41	Reverse run command (2-Wire sequence)	–
42	Run command (2-Wire sequence 2)	–
43	FWD/REV command (2-Wire sequence 2)	–
47	Node setup	–
51	Sequence Timer Disable	–
52	Sequence Timer Cancel	–
60	DC Injection Braking command	–
61	External Speed Search command 1	–
62	External Speed Search command 2	–
63	Field weakening	–
65	KEB Ride-Thru 1 (N.C.)	–
66	KEB Ride-Thru 1 (N.O.)	–

Setting	Function	Page
67	Communications test mode	–
68	High Slip Braking (HSB)	–
6A	Drive enable	–
73	Low City Press	–
75	Up 2 command	–
76	Down 2 command	–
7A	KEB Ride-Thru 2 (N.C.)	–
7B	KEB Ride-Thru 2 (N.O.)	–
80	HAND Mode	–
81	HAND Mode 2	–
82 <1>	PI Switch to Aux	–
83	Alternate Multi-Setpoint (Q1-02)	–
84	Alternate Multi-Setpoint (Q1-03)	–
85	Alternate Multi-Setpoint (Q1-04)	–
88	Volute-Thermostat Normally Open	–
89	Volute-Thermostat Normally Closed	–
8C	Disable Pre-Charge	–
8D	Multi Setpoint 1	–
8E	Multi Setpoint 2	–
8F	Low Water Level	–
90	High Water Level	–
92	Reset Accum	–
95	Remove Drive Disable	–
A8	Secondary PI Disable (N.O.)	–
A9	Secondary PI Disable (N.C.)	–
AA	Secondary PI Inverse Operation	–
AB	Secondary PI Integral Reset	–
AC	Secondary PI Integral Hold	–
AD	Select Secondary PI Parameters	–
AF	Emergency Override Forward Run	–
B0	Emergency Override Reverse Run	–

<1> Available in drive software versions PRG: 8552 and later.
Not available in drive models 4A0930 and 4A1200.

■ H2-01 to H2-03: Terminal M1-M2, M3-M4, and MD-ME-MF Function Selection

The drive has three multi-function output terminals. [Table i.23](#) lists the functions available for these terminals using H2-01, H2-02, and H2-03.

No.	Parameter Name	Setting Range	Default
H2-01	Terminal M1-M2 Function Selection (relay)	0 to 192	37: During Frequency Output
H2-02	Terminal M3-M4 Function Selection (relay)	0 to 192	42: Pressure Reached <1>
H2-03	Terminal MD-ME-MF Function Selection (relay)	0 to 192	E: Fault

<1> Default is F: Through Mode in drive software versions PRG: 8551 and earlier.

Table i.23 Multi-Function Digital Output Terminal Settings

Setting	Function	Page	Setting	Function	Page
0	During run	–	4	Frequency detection 1	–
1	Zero speed	–	5	Frequency detection 2	–
2	Speed agree 1	–	6	Drive ready	–
3	User-set speed agree 1	–	7	DC bus undervoltage	–

Setting	Function	Page	Setting	Function	Page
8	During baseblock (N.O.)	–	52	Sequence timer 2	–
9	Frequency reference source	–	53	Sequence timer 3	–
A	Run command source	–	54	Sequence timer 4	–
A	HAND Mode	–	58	Underload detection	–
B	Torque detection 1 (N.O.)	–	60	Internal cooling fan alarm	–
C	Frequency reference loss	–	71	Secondary PI Feedback Low	–
D <1>	Braking resistor fault	–	72	Secondary PI Feedback High	–
E	Fault	–	80	Pump 2 Control	–
F	Through mode	–	81	Pump 3 Control	–
10	Minor fault	–	82	Pump 4 Control	–
11	Fault reset command active	–	83	Pump 5 Control	–
12	Timer output	–	84	Pump 6 Control	–
13	Speed agree 2	–	89	Output 1 Limit	–
14	User-set speed agree 2	–	8B	Lube Pump or Digital Output Delay	–
15	Frequency detection 3	–	8F	Internal Fan On	–
16	Frequency detection 4	–	91	Pump Fault	–
17	Torque detection 1 (N.C.)	–	92	Transducer Loss	–
18	Torque detection 2 (N.O.)	–	93	Setpoint Not Met	–
19	Torque detection 2 (N.C.)	–	94	Loss of Prime	–
1A	During reverse	–	95	Volute Thermostat Fault	–
1B	During baseblock (N.C.)	–	96	High Feedback	–
1E	Restart enabled	–	97	Low Feedback	–
1F	Motor overload alarm (oL1)	–	98	Low Flow	–
20	Drive overheat pre-alarm (oH)	–	99	Accum Level	–
22	Mechanical weakening detection	–	9A	High Flow	–
2F	Maintenance period	–	9B	Low Water Level	–
30	During torque limit	61	9C	Low Suction	–
37	During frequency output	–	9D	High Suction	–
38	Drive enabled	–	9E	Low PI Aux Level	–
39	Watt hour pulse output	–	9F	High PI Aux Level	–
3D	During speed search	–	A0	Water Loss/Suction Pressure/PI Aux Control	–
3E	PID feedback low	–	A1	Differential Detected	–
3F	PID feedback high	–	A2	Sleep Active	–
40	Auto Mode	–	A3	Start Delay	–
42	Pressure Reached	61	A4	Pre-Charge	–
43	2 Motor Alternate	–	A5	Anti-Jam Active	–
4A	During KEB Ride-Thru	–	A6	De-Scale Active	–
4C	During fast stop	–	A7	Flow Rate Limit	–
4D	oH Pre-alarm time limit	–	A9	Thrust Mode	–
4E <2>	Braking transistor fault (tr)	–	AA	Utility Start Delay	–
4F <2>	Braking resistor overheat (oH)	–	100 to 1AA	Function 0 to AA with inverse output	–
51	Sequence timer 1	–			

<1> Not available in models 4A0930 and 4A1200.

<2> Not available in models 2A0169 to 2A0415 and 4A0088 to 4A1200.

Setting 30: During Torque Limit

The output closes when the motor is operating at the torque limit specified by the L7-□□ parameters or an analog input. This setting can only be used in OLV control mode.

Setting 42: Pressure Reached

- Note:**
1. Setting available in drive software versions PRG: 8552 and later.
 2. Setting not available in drive models 4A0930 and 4A1200.

i.5 Start-Up Programming and Operation

Pressure Setpoint has been reached. Activation and deactivation conditions based on the Pressure Feedback and the settings of P4-36 to P4-40.

Direct-acting PID

The terminal activates when the feedback meets or exceeds the setpoint for the time set in P4-38.

The terminal deactivates based on the hysteresis level (P4-37), delay time (P4-39), and the pressure reached exit conditions (P4-36).

When P4-36 = 0 (Hysteresis Above & Below), the terminal deactivates when the feedback falls below the setpoint – hysteresis level or when it rises above the setpoint + hysteresis level for the time set in P4-39.

When P4-36 = 1 (Hysteresis 1-Way), the terminal only deactivates when the feedback falls below the setpoint – hysteresis level for the time set in P4-39.

Inverse-acting PID

The terminal activates when the feedback meets or falls below the setpoint for the time set in P4-20.

The terminal deactivates based on the hysteresis level (P4-37), delay time (P4-39), and the pressure reached exit conditions (P4-36).

When P4-36 = 0 (Hysteresis Above & Below), the terminal deactivates when the feedback falls below the setpoint – hysteresis level or when it rises above the setpoint + hysteresis level for the time set in P4-39.

When P4-36 = 1 (Hysteresis 1-Way), the terminal only deactivates when the feedback rises above the setpoint + hysteresis level for the time set in P4-39.

■ H3-01: Terminal A1 Signal Level Selection

Selects the input signal level for analog input A1.

No.	Name	Setting Range	Default
H3-01	Terminal A1 Signal Level Selection	0 to 3	0

Setting 0: 0 to 10 Vdc

The input level is 0 to 10 Vdc. The minimum input level is limited to 0%, so that a negative input signal due to gain and bias settings will be read as 0%.

Setting 1: 0 to 10 Vdc Bipolar

The input level is -10 to 10 Vdc. If the resulting voltage is negative after being adjusted by gain and bias settings, then the motor will rotate in reverse.

Setting 2: 4 to 20 mA

Setting 3: 0 to 20 mA

■ H3-02: Terminal A1 Function Selection

Selects the input signal level for analog input A1.

No.	Name	Setting Range	Default
H3-02	Terminal A1 Function Selection	0 to 26	0

■ H3-03, H3-04: Terminal A1 Gain and Bias Settings

Parameter H3-03 sets the level of the selected input value that is equal to 10 Vdc input at terminal A1 (gain).

Parameter H3-04 sets the level of the selected input value that is equal to 0 V input at terminal A1 (bias).

Use both parameters to adjust the characteristics of the analog input signal to terminal A1.

No.	Name	Setting Range	Default
H3-03	Terminal A1 Gain Setting	-999.9 to 999.9%	100.0%
H3-04	Terminal A1 Bias Setting	-999.9 to 999.9%	0.0%

■ H3-05: Terminal A3 Signal Level Selection

Determines the function assigned to analog input terminal A3.

No.	Name	Setting Range	Default
H3-05	Terminal A3 Signal Level Selection	0 to 3	0

Setting 0: 0 to 10 Vdc

The input level is 0 to 10 Vdc. See the explanation provided for H3-01. [Refer to Setting 0: 0 to 10 Vdc on page 62.](#)

Setting 1: 0 to 10 Vdc Bipolar

The input level is -10 to 10 Vdc. See the explanation provided for H3-01. [Refer to Setting 1: 0 to 10 Vdc Bipolar on page 62.](#)

Setting 2: 4 to 20 mA

Setting 3: 0 to 20 mA

■ H3-06: Terminal A3 Function Selection

Determines the function assigned to analog input terminal A3.

No.	Name	Setting Range	Default
H3-06	Terminal A3 Function Selection	0 to 31	20

■ H3-07, H3-08: Terminal A3 Gain and Bias Setting

Parameter H3-07 sets the level of the selected input value that is equal to 10 Vdc input at terminal A3 (gain).

Parameter H3-08 sets the level of the selected input value that is equal to 0 V input at terminal A3 (bias).

No.	Name	Setting Range	Default
H3-07	Terminal A3 Gain Setting	-999.9 to 999.9%	100.0%
H3-08	Terminal A3 Bias Setting	-999.9 to 999.9%	0.0%

■ H3-09: Terminal A2 Signal Level Selection

Selects the input signal level for analog input A2. Set Jumper S1 on the terminal board accordingly for a voltage input or current input.

No.	Name	Setting Range	Default
H3-09	Terminal A2 Signal Level Selection	0 to 3	2

Setting 0: 0 to 10 Vdc

The input level is 0 to 10 Vdc. [Refer to Setting 0: 0 to 10 Vdc on page 62.](#)

Setting 1: 0 to 10 Vdc Bipolar

The input level is -10 to 10 Vdc. [Refer to Setting 1: 0 to 10 Vdc Bipolar on page 62.](#)

Setting 2: 4 to 20 mA

The input level is 4 to 20 mA. Negative input values by negative bias or gain settings will be limited to 0%.

Setting 3: 0 to 20 mA

The input level is 0 to 20 mA. Negative input values by negative bias or gain settings will be limited to 0%.

■ H3-10: Terminal A2 Function Selection

Determines the function assigned to analog input terminal A2.

No.	Name	Setting Range	Default
H3-10	Terminal A2 Function Selection	0 to 32	B

i.5 Start-Up Programming and Operation

■ H3-11, H3-12: Terminal A2 Gain and Bias Setting

Parameter H3-11 sets the level of the input value selected that is equal to 10 Vdc input or 20 mA input to terminal A2.

Parameter H3-12 sets the level of the input value selected that is equal to 0 V, 4 mA or 0 mA input at terminal A2.

Use both parameters to adjust the characteristics of the analog input signal to terminal A2. The setting works in the same way as parameters H3-03 and H3-04 for analog input A1.

No.	Name	Setting Range	Default
H3-11	Terminal A2 Gain Setting	-999.9 to 999.9%	100.0%
H3-12	Terminal A2 Bias Setting	-999.9 to 999.9%	0.0%

■ H4-01, H4-04: Multi-Function Analog Output Terminal FM, AM Monitor Selection

Sets the desired drive monitor parameter U□-□□ to output as an analog value via terminal FM and AM. Refer to the drive User Manual for a list of all monitors. The “Analog Output Level” column indicates whether a monitor can be used for analog output.

Example: Enter “103” for U1-03.

No.	Name	Setting Range	Default
H4-01	Multi-Function Analog Output Terminal FM Monitor Selection	000 to 999	102
H4-04	Multi-Function Analog Output Terminal AM Monitor Selection	000 to 999	103

A setting of 031 or 000 applies no drive monitor to the analog output. With either of these settings, the output level of the terminals FM and AM can be set by a PLC via a communication option or MEMOBUS/Modbus (through mode).

■ H4-02, H4-03: Multi-Function Analog Output Terminal FM Gain and Bias H4-05, H4-06: Multi-Function Analog Output Terminal AM Gain and Bias

Parameters H4-02 and H4-05 set the terminal FM and AM output signal level when the value of the selected monitor is at 100%. Parameters H4-03 and H4-06 set the terminal FM and AM output signal level when the value of the selected monitor is at 0%. Both are set as a percentage, where 100% equals 10 Vdc or 20 mA analog output and 0% equals 0 V or 4 mA. The output voltage of both terminals is limited to +/-10 Vdc.

The output signal range can be selected between 0 to +10 Vdc or -10 to +10 Vdc, or 4 to 20 mA using parameter H4-07 and H4-08.

No.	Name	Setting Range	Default
H4-02	Multi-Function Analog Output Terminal FM Gain	-999.9 to 999.9%	100.0%
H4-03	Multi-Function Analog Output Terminal FM Bias	-999.9 to 999.9%	0.0%
H4-05	Multi-Function Analog Output Terminal AM Gain	-999.9 to 999.9%	50.0%
H4-06	Multi-Function Analog Output Terminal AM Bias	-999.9 to 999.9%	0.0%

Using Gain and Bias to Adjust Output Signal Level

The output signal is adjustable while the drive is stopped.

■ H4-07, H4-08: Multi-Function Analog Output Terminal FM, AM Signal Level Selection

Sets the voltage output level of U parameter (monitor parameter) data to terminal FM and terminal AM using parameters H4-07 and H4-08.

Set jumper S5 on the terminal board accordingly when changing these parameters. *Refer to Terminal AM/FM Signal Selection on page 43* for details on setting S5.

No.	Name	Setting Range	Default
H4-07	Multi-Function Analog Output Terminal FM Signal Level Selection	0 to 2	0
H4-08	Multi-Function Analog Output Terminal AM Signal Level Selection	0 to 2	0

Setting 0: 0 to 10 V

Setting 1: -10 V to 10 V

Setting 2: 4 to 20 mA

■ **L5-01: Number of Auto Restart Attempts**

Sets the number of times that the drive may attempt to restart itself.

When the counter reaches the number set to L5-01, the operation stops and the fault must be manually cleared and reset.

The restart counter is incremented at each restart attempt, regardless of whether the attempt was successful. When the counter reaches the number set to L5-01, the operation stops and the fault must be manually cleared and reset.

The number of fault restarts is reset to zero when:

- The drive operates normally for 10 minutes following a fault restart.
- A fault is cleared manually after protective functions are triggered.
- The power supply is cycled.

No.	Name	Setting Range	Default
L5-01	Number of Auto Restart Attempts	0 to 10 Times	5 Times

■ **L5-04: Fault Reset Interval Time**

Determines the amount of time to wait between restart attempts when parameter L5-05 is set to 1.

No.	Name	Setting Range	Default
L5-04	Fault Reset Interval Time	0.5 to 600.0 s	10.0 s

■ **P1-01: Pump Mode**

Selects the base operation mode of the drive controller.

No.	Parameter Name	Setting Range	Default
P1-01	Pump Mode	0, 1, 3	0

Setting 0: Drive only

Designed for single pump stand-alone applications

Setting 1: Contactor lag

Contactor Lag systems multiplex a main pump with up to 5 lag pumps. The drive will stage and de-stage the lag pumps based on system demand by using its digital output contacts to control the lag pump motor starters

Setting 3: MEMOBUS network

Up to eight drives can be networked together to provide for system redundancy and precise control.

When P6-01 > 0, the Flow Rate can come from another drive on the MEMOBUS Network.

Setting P9-40 to 0 (Analog) will read the Flow Meter from the analog terminal (H3-□□ = 22) or from the pulse input (H6-01 = 5), while setting P9-40 to 3 (Network) will read the Flow Meter information from the network. When there is no such drive on the network, a “Net Flow Meter Lost, Chk Source” alarm is triggered for drives with P9-40 set to 3 (Network) and P6-01 > 0.

Staging is disabled when and the drive PI output is influenced by the Water Level / Suction Pressure Control.

The functions listed below will behave slightly different when P1-01 is set to 3:

- **Start Level:** Active on the first pump in the network. Drives in the process of alternation will not undergo this process.
- **Sleep:** Active when the drive is the only drive running on the network.
- **Over-cycle Protection:** Active when the drive is the only drive running on the network.
- **Pre-charge:** Active only on the first drive to run in the network.
- **Low City Pressure:** Active on any drive in the network. An alarm condition will cause other drives in the network to stop running and show a “Net Pump Err” message.
- **Utility Delay:** When this function is active, the drive is unavailable to the MEMOBUS Network and will force the Home Screen text to show “Pump Off Network”.
- **Remote Drive Disable:** When this function is active, the drive is unavailable to the MEMOBUS Network and will force the Home Screen text to show “Pump Off Network”.

i.5 Start-Up Programming and Operation

■ P1-02: System Units

Selects the base unit in which most drive PID setpoints, scaling, monitors, limits, and faults/alarm levels will be set.

Note: Set this parameter prior to changing other parameters, as internal scaling is based on P1-02.

No.	Parameter Name	Setting Range	Default
P1-02	System Units	0 to 10; 25, 26	1

Setting 0: No unit

Setting 1: PSI: Pounds per square inch

Setting 2: Pa: Pascals

Setting 3: Bar: Bar

Setting 4: "WC: Inch of water

Setting 5: "Hg: Inch of Mercury

Setting 6: ft: feet

Setting 7: m: meters

Setting 8: °F: Degrees Fahrenheit

Setting 9: °C: Degrees Celsius

Setting 10: Percent

Setting 25: Flow (Use P6-04)

Note: When using setting 25, the system units are set by parameter P6-04 and the PID feedback is re-routed to come from the flow meter, pulse input (H6-01 = 5), or analog (H3-0□ = 22).

Setting 26: Custom (P1-32 to P1-34)

This setting allows the user to create a custom system unit display with up to three characters. Use parameters P1-32 to P1-34 to make the custom system unit.

■ P1-03: Feedback Device Scaling

Sets the feedback device scaling used for the PID controller. This information can be found on the nameplate or specification sheet and is usually expressed as the maximum output of the device.

For example, a pressure sensor scaling might be 145.0 PSI at 20 mA output and would require setting P1-03 to 145.0 PSI.

Note: Set this parameter prior to changing other parameters related to the PID feedback, as internal scaling is based on P1-03.

No.	Parameter Name	Setting Range	Default
P1-03	Feedback Device Scaling	0.1 to 6000.0	145.0 PSI

■ P1-04: Start / Draw Down Level

Sets the wake up level from the Sleep function. This setting is dependent on whether PID is normal or inverse acting (b5-09). When the drive is asleep and the PID feedback signal rises above (normal acting) or falls below (inverse acting) this setting for the time set in P1-05, Start Level Delay Time, the drive will wake up.

This parameter activates the sleep function when the pump reaches the minimum pump speed set in P1-06 for the time set in P2-03.

No.	Parameter Name	Setting Range	Default
P1-04	Start / Draw Down Level	<1>	0.0 PSI

<1> Range is 0.0 to 999.9 with sign-bit "-" or "+" indicating Delta to Setpoint.
Range is -999.9 to 999.9 in drive software versions PRG: 8551 and earlier.

■ P1-05: Start Level Delay Time

Sets the delay time for waking the drive to prevent accidental wake up caused by erratic feedback.

No.	Parameter Name	Setting Range	Default
P1-05	Start Level Delay Time	0 to 3600 s	1 s

■ P1-06: Minimum Pump Speed

Sets the minimum speed at which the drive will run the pump. Most pumps cannot run at low speeds due to cavitation, so be sure to consult the pump specification sheet for the minimum safe run speed.

No.	Parameter Name	Setting Range	Default
P1-06	Minimum Pump Speed	0.0 to E1-04	40.0 Hz

■ P1-08: Low Feedback Level

Sets the level at which a Low Feedback alarm or fault will occur. When the PID feedback falls below the P1-08 setting for the time set in P1-09, the drive will respond based on the setting in P1-10.

No.	Parameter Name	Setting Range	Default
P1-08	Low Feedback Level	<>	0.0 PSI

<1> Range is 0.0 to 999.9 with sign-bit “-” indicating Delta to Setpoint.
 Range is 0.0 to 6000.0 in drive software versions PRG: 8551 and earlier.

■ P1-09: Low Feedback Level Fault Delay Time

Sets the delay time after which a Low Feedback alarm or fault will occur. When the PID feedback falls below the P1-08 setting for the time set in P1-09, the drive will respond based on the setting in P1-10.

No.	Parameter Name	Setting Range	Default
P1-09	Low Feedback Level Fault Delay Time	0 to 3600 s	10 s

■ P1-10: Low Feedback Selection

Selects the drive response to a Low Feedback condition. When the PID feedback falls below the P1-08 setting for the time set in P1-09, the drive will respond based on the setting in P1-10.

No.	Parameter Name	Setting Range	Default
P1-10	Low Feedback Selection	0 to 2	0

Low feedback detection is enabled when:

- P1-08 > 0.0
- Drive is running in AUTO Mode, including sleep boost and feedback drop detection (standard PID, b5-09 = 0)
- Run Command is present (including sleep and timer operation) (inverse PID, b5-09 = 1)

Setting 0: Fault

When feedback drops below the P1-08 level for longer than the time set in P1-09, the drive will fault on the “LFB – Low Feedback” fault and coast to a stop.

The digital output programmed to “Low Feedback” (H2-0□ = 97) closes. The drive will also display the “Low Feedback – Low FB Sensed” alarm. The digital output will remain closed until the fault is reset.

Setting 1: Alarm

When feedback drops below the P1-08 level for longer than the time set in P1-09, the digital output programmed to “Low Feedback” (H2-0□ = 97) closes and the drive displays the “Low Feedback – Low FB Sensed” alarm.

When feedback rises above the level determined by P1-08 and P1-14, or when one or more of the conditions that enable low feedback detection are no longer true, the digital output will open and the alarm will clear.

Setting 2: Digital out only

When feedback drops below the P1-08 level for longer than the time set in P1-09, the digital output programmed to “Low Feedback” (H2-0□ = 97) closes.

When feedback rises above the level determined by P1-08 and P1-14, or when one or more of the conditions that enable low feedback detection are no longer true, the digital output will open.

i.5 Start-Up Programming and Operation

■ P1-11: High Feedback Level

Sets the level at which a High Feedback alarm or fault will occur. When the PID feedback rises above the P1-11 setting for the time set in P1-12, the drive will respond based on the setting in P1-13.

No.	Parameter Name	Setting Range	Default
P1-11	High Feedback Level	</>	155.0 PSI

<1> Range is 0.0 to 999.9 with sign-bit “+” indicating Delta to Setpoint.
Range is 0.0 to 6000.0 in drive software versions PRG: 8551 and earlier.

■ P1-12: High Feedback Level Fault Delay Time

Sets the delay time after which a Low Feedback alarm or fault will occur. When the PID feedback rises above the P1-11 setting for the time set in P1-12, the drive will respond based on the setting in P1-13.

No.	Parameter Name	Setting Range	Default
P1-12	High Feedback Level Fault Delay Time	0 to 3600 s	5 s

■ P1-13: High Feedback Selection

Selects the drive response to a High Feedback condition. When the PID feedback rises above the P1-11 setting for the time set in P1-12, the drive will respond based on the setting in P1-13.

No.	Parameter Name	Setting Range	Default
P1-13	High Feedback Selection	0 to 2	0

High feedback detection is enabled when:

- P1-11 > 0
- Run Command present, including sleep & timer operation (standard PID, b5-09 = 0)
- Drive is running in AUTO Mode, including feedback drop detection (inverse PID, b5-09 = 1).

Setting 0: Fault

When feedback rises above the P1-11 for longer than the time set in P1-12, the drive will fault on the “HFB – High Feedback” fault and coast to a stop.

The digital output programmed to “High Feedback” (H2-0□= 96) closes. The drive will also display the “High Feedback – High FB Sensed” alarm. The digital output will remain closed until the fault is reset.

Setting 1: Alarm

When feedback rises above the P1-11 for longer than the time set in P1-12, the digital output programmed to “High Feedback” (H2-0□= 96) closes and the drive displays the “High Feedback – High FB Sensed” alarm.

When feedback falls below the level determined by P1-11 and P1-14, or when one or more of the conditions that enable high feedback detection are no longer true, the digital output will open and the alarm will clear.

Setting 2: Digital out only

When feedback rises above the P1-11 for longer than the time set in P1-12, the digital output programmed to “High Feedback” (H2-0□= 96) closes.

When feedback falls below the level determined by P1-11 and P1-14, or when one or more of the conditions that enable high feedback detection are no longer true, the digital output will open.

■ P2-01: Sleep Level Type

Selects which data source the drive will use to determine if it should activate the sleep function. This parameter is application-dependent and should be set in conjunction with the type of system data is available. Choose the data type that best represents a low-activity condition for the system.

Note: Set this parameter prior to changing other parameters related to the Sleep Function, as internal scaling is based on P2-01.

No.	Parameter Name	Setting Range	Default
P2-01	Sleep Level Type	0 to 4	0

Setting 0: Output frequency

Setting 1: Output current

Setting 2: Feedback

Setting 3: Output speed (RPM)

Setting 4: Flow meter (requires flow meter)

■ **P2-02: Sleep Level**

Sets the level at which the drive will enter sleep mode. The drive will enter sleep mode when the monitored data falls below the P2-02 setting for the time set in P2-03.

No.	Parameter Name	Setting Range	Default
P2-02	Sleep Level	0.0 to 6000.0	0.0 Hz

■ **P2-03: Sleep Delay Time**

Sets the delay time after which the drive will enter sleep mode. The drive will enter sleep mode when the monitored data falls below the P2-02 setting for the time set in P2-03.

No.	Parameter Name	Setting Range	Default
P2-03	Sleep Delay Time	0 to 3600 s	5 s

■ **P3-00: Number of Lag Pumps**

Sets the number of lag pumps in the system. When using Contactor Multiplexing for the control lag pumps, first set P1-01 to 1. Then select the number of lag pumps to be controlled in P3-00. Set the corresponding multi-function digital outputs for lag pumps (H2-□□ = 80-82 and F5-□□ = 83-84). The methods used to determine lag pump staging and de-staging order are selected in P1-30 and P1-31.

No.	Parameter Name	Setting Range	Default
P3-00	Number of Lag Pumps	1 to 5	1

■ **P3-50: Pump 2 Frequency Shutdown Level**

Sets the level at which the first lag pump (2nd pump in the system) will shut down or de-stage. This parameter is effective when the P3-01 is set to 0 or 2 (pump staging is based on output frequency). When the output frequency falls below the P3-50 level for the time set in P3-09, the pump will be de-staged.

No.	Parameter Name	Setting Range	Default
P3-50	Pump 2 Frequency Shutdown Level	0.0 to 400.0	40.0 Hz

■ **P3-60: Pump 3 Frequency Shutdown Level**

Sets the level at which the second lag pump (3rd pump in the system) will shut down or de-stage. This parameter is effective when the P3-01 is set to 0 or 2 (pump staging is based on output frequency). When the output frequency falls below the P3-50 level for the time set in P3-09, the pump will be de-staged.

No.	Parameter Name	Setting Range	Default
P3-60	Pump 3 Frequency Shutdown Level	0.0 to 400.0	40.0 Hz

■ **P3-70: Pump 4 Frequency Shutdown Level**

Sets the level at which the third lag pump (4th pump in the system) will shut down or de-stage. This parameter is effective when the P3-01 is set to 0 or 2 (pump staging is based on output frequency). When the output frequency falls below the P3-50 level for the time set in P3-09, the pump will be de-staged.

No.	Parameter Name	Setting Range	Default
P3-70	Pump 4 Frequency Shutdown Level	0.0 to 400.0	40.0 Hz

■ **P4-01: Pre-Charge Level**

Sets the level at which the drive will activate the pre-charge function. At start, if the PID is below the P4-01 setting, the drive will run at the P4-02 frequency setting for the time set in P4-03. PID control is delayed until the Pre-charge function stops. The drive will exit the pre-charge function early if the feedback rises above the P4-01 setting or if a Low Water digital input switch (H1-□□ = 8F) deactivates. Pre-charge is useful to slowly fill or pressurize a system.

i.5 Start-Up Programming and Operation

No.	Parameter Name	Setting Range	Default
P4-01	Pre-Charge Level	0.0 to 6000.0	0.0 PSI

■ P4-02: Pre-Charge Frequency

Sets the frequency at which the pre-charge function will run.

No.	Parameter Name	Setting Range	Default
P4-02	Pre-Charge Frequency	0.0 to E1-04	0.0 Hz

■ P4-03: Pre-Charge Time

Sets the duration of time that the Pre-Charge function will run.

No.	Parameter Name	Setting Range	Default
P4-03	Pre-Charge Time	0.0 to 3600.0 min	0.0 min

The following conditions must be met to enter Pre-Charge Mode:

- Drive Ready or Sleeping (Run command, not faulted, not in program mode)
- NOT in HAND Mode
- “Disable Pre-charge” digital input NOT closed
- P4-03 > 0.0
- If P4-01, Pre-Charge Level, is greater than 0, the PID feedback must be below the P4-01 level. (Forward acting PID, b5-09 = 0, Reverse acting PID, b5-09 = 1).

When the drive enters Pre-Charge Mode 1 and 2, the drive runs at the Pre-Charge frequency set in P4-02/P4-06, the PID controller is disabled and the Pre-Charge digital output (H2-0□ = A4) closes.

When pre-charge is active, the message “Pre Chg Mode Exit in Xsec” appears on the keypad to show how long before pre-charge exits via timers (P4-03 + P4-07).

Additionally, during Pre-Charge Mode:

- When Pre-charge Level 2 (P4-32) is set to 0, the system can exit Pre-charge when the PID Feedback goes above the Pre-charge Level (P4-01) in normal PID operation, or below the P4-01 level in inverse PID operation.
However, when Pre-charge Level 2 (P4-32) is set to a non-zero value, the system goes into Pre-Charge 2 instead when Pre-Charge 1 completes via timer (P4-03) or level (P4-01). At this point, the drive will run at Pre-charge Frequency 2 (P4-06).
The system can exit Pre-charge 2 when the PID Feedback goes above the Pre-charge Level 2 (P4-32) in normal PID operation, or below the P4-32 level in inverse operation. Refer to [Figure i.31](#) and [Figure i.32](#) for more information.
- When P4-02, Pre-Charge Frequency, or P4-06, Pre-Charge Frequency 2, are set to a value less than P1-06, Minimum Pump Speed, the alarm “Freq. Ref < Pump Min P1-06” is displayed and the drive runs at the minimum speed.
- When Pre-Charge Loss of Prime parameters P4-05 and P4-08 are set to 0, the Loss of Prime detection is disabled.
- When Pre-Charge Loss of Prime parameters P4-05 or P4-08 are set to a value greater than 0, Loss of Prime detection will operate after the output speed reaches the Pre-Charge Frequency set in P4-02 or P4-06.
- The “Low Water” fault (H1-0□ = 8F) is disabled.
- The “Low Feedback” fault is disabled when forward-acting PID is selected (b5-09 = 0) and the “High Feedback” fault is disabled when reverse-acting PID is selected (b5-09 = 1).
- The “Not Maintaining Setpoint” fault is disabled.
- The “Feedback Loss” detection (4 to 20 mA wire break) is enabled, however, the Pre-Charge frequencies will override and the b5-13 “feedback loss goto speed”.

The drive will always exit Pre-Charge Mode when Pre-Charge times P4-03 and P4-07 have expired. The drive will also exit Pre-Charge Mode when one of the following conditions are met:

- P4-03 and P4-32 are set to 0.0
- The “Disable Pre-Charge” digital input (H1-0□ = 8C) closes.
- A digital input programmed to “Low Water” (H1-0□ = 8F) is deactivated (open when P1-30 = 0 or closed when P1-30 = 1).
- The PID feedback satisfies both Pre-charge levels 1 and 2 (all must be true):
Pre-charge timers P4-03 and P4-07 have NOT expired
PID is enabled (b5-01 > 0).

PID is NOT disabled via digital input

Pre-Charge Level Set (P4-01 > 0) (and if used, P4-32 > 0)

Feedback is greater than Pre-Charge Level (P4-01) and Pre-charge Level 2 (P4-32) (forward-acting PID, b5-09 = 0) or less than Pre-Charge Levels 1 and 2 (reverse-acting PID, b5-09 = 1)

Drive is NOT in a “Feedback Loss” condition (4 to 20 mA wire-break detection).

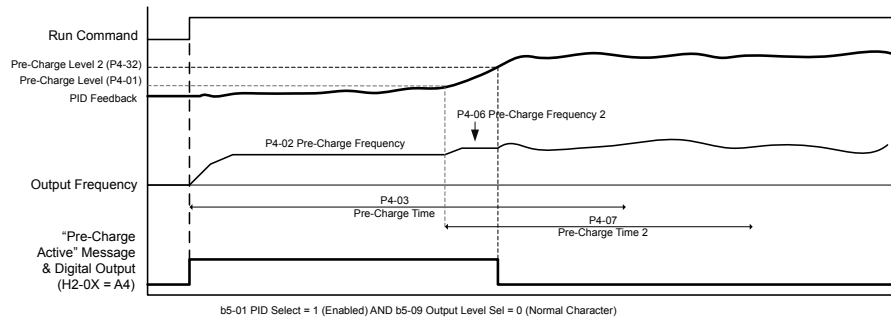

Figure i.31 Pre-Charge 1 and 2 Complete via PID Feedback

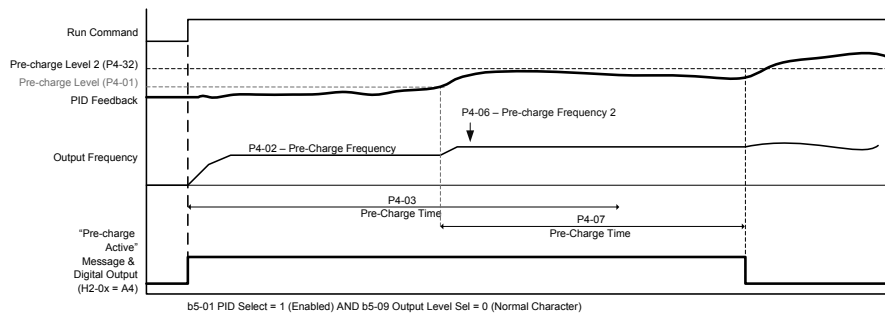

Figure i.32 Pre-Charge 1 Complete via PID Feedback & Pre-Charge 2 via Timer

■ **P4-10: AUTO Mode Operator Run Power Down Storage**

Selects drive response to power loss with regards to the Run command. When running in AUTO Mode and using a Run command from the keypad (b1-02 = 0), P4-10 determines whether the drive will automatically start running when power is reapplied. The factory setting of this parameter requires pressing the AUTO key to start the drive after power loss.

WARNING! Sudden Movement Hazard. If the drive is running at power loss, it will automatically initiate an internal Run command upon power-up if P4-10 = 1 (Enabled) and could result in death or serious injury from moving equipment.

No.	Parameter Name	Setting Range	Default
P4-10	AUTO Mode Operator Run Power Down Storage	0, 1	0

Setting 0: Disabled

Setting 1: Enabled

■ **P4-12: Thrust Bearing Frequency**

Sets the frequency used by the drive when determining which acceleration and deceleration time to use. The Thrust Bearing function is used for applications using submersible motors. The function provides an alternate acceleration time (P4-11) and deceleration time (P4-13) for protecting the pump bearings.

At start, the drive will use the P4-11 acceleration time until the P4-12 frequency is reached, at which time it will use the active C1-□□ acceleration and deceleration times. At stop, if the output frequency is above the P4-12 setting, the active C1-□□ deceleration time will be used until the P4-12 setting is reached at which time it will use the P4-13 time setting for the rest of deceleration.

If P4-12 is set greater than P1-06 (minimum Pump Speed), P4-12 will become the frequency lower limit. The drive PID control must be disabled (b5-01 = 0) for this function to work.

No.	Parameter Name	Setting Range	Default
P4-12	Thrust Bearing Frequency	0.0 to E1-04	30.0 Hz

i.5 Start-Up Programming and Operation

■ P4-17: Utility Start Delay

Sets the delay time after power up until the drive will recognize a Run command present within one second of power up or when the Run command is jumpered on the terminal strip.

This is useful in preventing a peak power surge when multiple drives power up and begin accelerating simultaneously. This function works when the drives all have different P4-17 settings to spread out the power draw during acceleration.

If the Run command is removed and re-applied during the P4-17 time, the drive will cancel the utility start delay and immediately begin running.

The Utility Start Delay is applied when the drive is auto-restarting after an Undervoltage (Uv) or an Overvoltage (ov) condition.

No.	Parameter Name	Setting Range	Default
P4-17	Utility Start Delay	0.0 to 1000.0 min	0.2 min

■ P5-02: HAND Reference 1

Sets the frequency reference of HAND mode. When the drive is stopped, pressing the HAND key will start the drive and the drive will accelerate to the P5-02 setting.

No.	Parameter Name	Setting Range	Default
P5-02	HAND Reference 1	0.0 to E1-04	40.0 Hz

■ P5-04: HAND Key Function Selection

Selects whether the HAND key on the HOA keypad is active. Disabling this function by setting P5-04 to 0 will prevent the drive from entering HAND Mode.

No.	Parameter Name	Setting Range	Default
P5-04	HAND Key Function Selection	0, 1	1

Setting 0: Disabled

Setting 1: Enabled

■ Q1-01: PID Controller Setpoint 1

Sets the PID setpoint for the controller. The drive will use the system feedback signal and modulate the pump speed to regulate the feedback at the Q1-01 setpoint. The units for Q1-01 are selected by b1-01 and the scaling is set in parameter P1-03. This parameter is active when b1-01 (Reference Source) is set to 0 (HOA keypad).

No.	Parameter Name	Setting Range	Default
Q1-01	PID Controller Setpoint 1	0.0 to 6000.0	0.0 PSI

◆ No-Load Operation Test Run

This section explains how to operate the drive with the motor decoupled from the load during a test run.

■ Before Starting the Motor

Check the following items before operation:

- Ensure the area around the motor is safe.
- Ensure external emergency stop circuitry is working properly and other safety precautions have been taken.

■ During Operation

Check the following items during operation:

- The motor should rotate smoothly (i.e., no abnormal noise or oscillation).
 - The motor should accelerate and decelerate smoothly.
-

◆ Test Run with the Load Connected

After performing a no-load test run, connect the motor and proceed to run the motor and load together.

■ Checklist Before Operation

- The motor should rotate in the proper direction.

- The motor should accelerate and decelerate smoothly.

■ Operating the Motor under Loaded Conditions

Test run the application similarly to the no-load test procedure when connecting the machinery to the motor.

- Monitor U1-03 for overcurrent during operation.
- If the application permits running the load in the reverse direction, change the motor direction and the frequency reference while watching for abnormal motor oscillation or vibration.
- Correct any problems that occur with hunting, oscillation, and other control-related issues.

i.6 Troubleshooting

NOTICE

Refer to the iQpump1000 Drive User Manual TOEP YAIP1W 01 for information on **Troubleshooting** and complete product instructions necessary for proper installation, set-up, troubleshooting and maintenance.

The iQpump1000 Drive Quick User Manual is posted on the Yaskawa website, www.yaskawa.com.

◆ Fault Detection

■ Fault Displays

HOA Keypad Display	Fault Name
ACCUM Accum Level	Accumulated Level Fault The total volume of water flow measured over time by the flow meter has exceeded the fault level setting.
AJF Anti-Jam Fault	Anti-Jam Fault
AUXFB PI Aux Lvl Loss	Wire-break detection for PI Aux Feedback Level
bAT	Digital Operator Battery Voltage Low
boL	Braking Transistor Overload Fault The braking transistor reached its overload level.
bUS	Option Communication Error <ul style="list-style-type: none"> The connection was lost after establishing initial communication. Only detected when the run command frequency reference is assigned to an option card.
CE	MEMOBUS/Modbus Communication Error Control data was not received for the CE detection time set to H5-09.
CPF11 to CPF14 CPF16 to CPF19	Control Circuit Error
CPF02	A/D Conversion Error An A/D conversion error or control circuit error occurred.
CPF03	Control Board Connection Error Connection error between the control board and the drive
CPF06	EEPROM Memory Data Error Error in the data saved to EEPROM
CPF07 or CPF08	Terminal Board Connection Error
CPF20 or CPF21	Control Circuit Error
CPF22	Hybrid IC Failure
CPF23	Control Board Connection Error Connection error between the control board and the drive
CPF24	Drive Unit Signal Fault The drive capacity cannot be detected correctly (drive capacity is checked when the drive is powered up).
CPF25	Terminal Board Not Connected
CPF26 to CPF35 CPF40 to CPF43	Control Circuit Error CPU error
DIFF Differential Det	Differential Feedback Detected
E5	SI-T3 Watchdog Timer Error The watchdog timed out.
EF0	Option Card External Fault An external fault condition is present.
EF1	Pump Fault (input terminal S1) External fault at multi-function input terminal S1.

HOA Keypad Display	Fault Name
EF2	Pump Fault (input terminal S2)
	External fault at multi-function input terminal S2.
EF3	Pump Fault (input terminal S3)
	External fault at multi-function input terminal S3.
EF4	Pump Fault (input terminal S4)
	External fault at multi-function input terminal S4.
EF5	Pump Fault (input terminal S5)
	External fault at multi-function input terminal S5.
EF6	Pump Fault (input terminal S6)
	External fault at multi-function input terminal S6.
EF7	Pump Fault (input terminal S7)
	External fault at multi-function input terminal S7.
EF8	Pump Fault (input terminal S8)
	External fault at multi-function input terminal S8.
Err	EEPROM Write Error
	Data cannot be written to the EEPROM
FAn	Internal Fan Fault
	Fan or magnetic contactor failure
FDBKL Wire Break	PID Feedback Loss
	The analog input programmed for PID feedback has risen above 21 mA or fallen below 3 mA.
Flow Rate Limit	Drive output speed is being limited due to the Flow Rate (U1-83).
GF	Ground Fault
	<ul style="list-style-type: none"> A current short to ground exceeded 50% of rated current on the output side of the drive. Setting L8-09 to 1 enables ground fault detection.
HFB	High Feedback
	The feedback signal is too high.
HIAUX High PI Aux Lvl	High PI Auxiliary Feedback Level
HIFLO High Flow	High Flow The meter has detected a high flow condition.
HISUC High Suction	High Section Pressure
HWL	High Water Level
	The "High Water Level" digital input is active (H1-0□ = 90).
LF	Output Phase Loss
	<ul style="list-style-type: none"> Phase loss on the output side of the drive. Setting L8-07 to 1 or 2 enables Phase Loss Detection.
LF3 </>	Power Unit Output Phase Loss 3
	<ul style="list-style-type: none"> Phase loss occurred on the output side Setting L8-78 to 1 enables Power Unit Output Phase Loss Protection
LFB	Low Feedback
	The feedback signal is too low.
LOAUX Low PI Aux Lvl	Low PI Auxiliary Feedback Level
LOP	Loss of Prime
	The pump has lost its prime.
LOSUC Low Suction	Low Section Pressure
LOWFL Low Flow	Low Flow
LOWWL Low Water Level	Low Water Level

i.6 Troubleshooting

HOA Keypad Display	Fault Name
LWL	Low Water Level The “Low Water Level” digital input is active (H1-0□ = 8F).
MSL Net Master Lost	Net Master Lost The MEMOBUS master has been lost
NMS	Not Maintaining Setpoint The setpoint cannot be maintained and P1-17 is set to 0.
nSE	Node Setup Error A terminal assigned to the node setup function closed during run.
oC	Overcurrent Drive sensors detected an output current greater than the specified overcurrent level.
oFA00	Option Card Connection Error at Option Port CN5-A Option compatibility error
oFA01	Option Card Fault at Option Port CN5-A Option not properly connected
oFA03 to oFA06 oFA10, oFA11	Option Card Error Occurred at Option Port CN5-A
oFA12 to oFA17	Option Card Connection Error (CN5-A)
oFA30 to oFA43	Communication Option Card Connection Error (CN5-A)
oFb00	Option Card Fault at Option Port CN5-B Option compatibility error
oFb01	Option Card Fault at Option Port CN5-B Option not properly connected
oFb02	Option Card Fault at Option Port CN5-B Same type of option card is currently connected
oFb03 to oFb17	Option card error occurred at Option Port CN5-B
oFC00	Option Card Connection Error at Option Port CN5-C Option compatibility error
oFC01	Option Card Fault at Option Port CN5-C Option not properly connected
oFC02	Option Card Fault at Option Port CN5-C Same type of option card is currently connected
oFC03 to oFC17	Option Card Error Occurred at Option Port CN5-C
oFC50 to oFC55	Option Card Error Occurred at Option Port CN5-C
oH	Heatsink Overheat The heatsink temperature exceeded the overheat pre-alarm level set to L8-02.
oH1	Overheat 1 (Heatsink Overheat) The heatsink temperature exceeded the drive overheat level.
oH4	Motor Overheat Fault (PTC Input) <ul style="list-style-type: none"> The motor overheat signal to analog input terminal A1, A2, or A3 exceeded the fault detection level. Detection requires setting multi-function analog inputs H3-02, H3-10, or H3-06 to E.
oH5 </>	Motor Overheat (NTC Input) The motor temperature exceeded the level set to L1-16 (or L1-18 for motor 2)
oL1	Motor Overload The electronic motor overload protection tripped
oL2	Drive Overload The thermal sensor of the drive triggered overload protection.
oL3	Overtorque Detection 1 The current has exceeded the value set for torque detection (L6-02) for longer than the allowable time (L6-03).

HOA Keypad Display	Fault Name
oL4	Overtorque Detection 2
	The current has exceeded the value set for Overtorque Detection 2 (L6-05) for longer than the allowable time (L6-06).
oL7	High Slip Braking oL
	The output frequency stayed constant for longer than the time set to n3-04 during High Slip Braking.
oPr	External HOA Keypad Connection Fault
	The HOA keypad has been disconnected from the drive. Note: An oPr fault will occur when all of the following conditions are true: • Output is interrupted when the keypad is disconnected (o2-06 = 1). • The Run command is assigned to the operator (b1-02 = 0 and LOCAL has been selected).
ov	Overvoltage
	Voltage in the DC bus has exceeded the overvoltage detection level. • For 200 V class drives: approximately 410 V • For 400 V class drives: approximately 820 V (740 V when E1-01 is less than 400) • For 600 V class drives: approximately 1040 V
PF	Input Phase Loss
	Drive input power has an open phase or has a large imbalance of voltage between phases. Detected when L8-05 is set 1 (enabled).
PoC	Pump Over Cycle
rF	Braking Resistor Fault
	The resistance of the braking resistor is too low.
rH	Braking Resistor Overheat
	Braking resistor protection was triggered. Fault detection is enabled when L8-01 = 1 (disabled as a default).
rr	Dynamic Braking Transistor
	The built-in dynamic braking transistor failed.
SC	IGBT Short Circuit or Ground Fault
SEr	Too Many Speed Search Restarts
	The number of Speed Search restarts exceeded the value set to b3-19.
SPL Suction Pressure Loss	Suction Pressure Loss
	Wire-break detection for suction pressure.
TdE	Time Data Error
THo </>	Thermistor Disconnect
	The thermistor that detects motor temperature has become disconnected.
TIE	Time Interval Error
TIM	Time Not Set
TLGI Geothermal Input	Temperature Lost Geothermal Input
	The geothermal input is not present.
UL3	Undertorque Detection 1
	The current has fallen below the minimum value set for torque detection (L6-02) for longer than the allowable time (L6-03).
UL4	Undertorque Detection 2
	The current has fallen below the minimum value set for torque detection (L6-05) for longer than the allowable time (L6-06).
UL6	Motor Underload
	The load has fallen below the underload curve defined in L6-14.
UnbC </>	Current Unbalance
	Current flow has become unbalanced.

i.6 Troubleshooting

HOA Keypad Display	Fault Name
Uv1	DC Bus Undervoltage
	One of the following conditions occurred while the drive was running: <ul style="list-style-type: none"> • Voltage in the DC bus fell below the undervoltage detection level (L2-05). • For 200 V class drives: approximately 190 V • For 400 V class drives: approximately 380 V (350 V when E1-01 is less than 400) • For 600 V class drives: approximately 475 V The fault is output only if L2-01 is set to 0 or 1 and the DC bus voltage has fallen below the level set to L2-05 for longer than the time set to L2-02.
Uv2	Control Power Supply Voltage Fault
	Voltage is too low for the control drive input power.
Uv3	Undervoltage 3 (Soft-Charge Bypass Circuit Fault)
	The soft-charge bypass circuit failed.
Uv4 <1>	Gate Drive Board Undervoltage
	Voltage drop in the gate drive board circuit
VLTS	Volute-Thermostat Fault
voF	Output Voltage Detection Fault
	Problem detected with the voltage on the output side of the drive.
WLL Water Level Loss	Water Level Loss

<1> Detected in models 4A0930 and 4A1200.

◆ Alarm Detection

■ Alarm Codes

An alarm is indicated by a code on the data display and the flashing ALM LED. The drive output is not necessarily switched off.

To remove an alarm, trace and remove the cause, and reset the drive by pushing the Reset key on the operator or cycle the power supply.

Refer to the drive User Manual for a complete list of causes and possible solutions.

HOA Keypad Display	Alarm Name
ACCUM Accum Level	Accumulated Level Error
	The total volume of water flow measured over time by the flow meter has exceeded the fault level setting.
Accum Lvl Reached Cycle Run Cmd	Flow Accumulation level reached
AnalogFB Lost Switched to Net	Analog Feedback Lost
	Analog feedback has not been detected and the network PI feedback signal is now used.
Anti-Jam Active	Anti-Jam Alarm
AUXFB PI Aux Lvl Loss	Wire-break detection for PI Aux Feedback Level
Backup FdBk Lost Check/Replace	Backup Feedback Device (H3-□□ = 24) lost.
bAT	Digital Operator Battery Voltage Low
bb	Baseblock
	Drive output interrupted as indicated by an external baseblock signal.
boL	Braking Transistor Overload Fault
	The braking transistor in the drive has been overloaded.
bUS	Option Communication Error
	<ul style="list-style-type: none"> • The connection was lost after initial communication was established. • Assign a Run command frequency reference to the option.
CALL	Serial Communication Transmission Error
	Communication has not yet been established.

HOA Keypad Display	Alarm Name
CE	MEMOBUS/Modbus Communication Error
	Control data was not received correctly for two seconds.
CE – Comm Loss Run at H5-14	MEMOBUS/Modbus Communicator Error. Drive runs at H5-14.
Current Limit Foldback	Current Limit Foldback
De-Scale/De-rag Active	De-scale is running
Differential FB Detected	Differential Feedback Detected
dnE	Drive Disabled
EF	Forward/Reverse Run Command Input Error
	Both forward run and reverse run closed simultaneously for longer than 0.5 s.
EF0	Option Card External Fault
	An external fault condition is present.
EF1	Pump Fault (Input Terminal S1)
	External fault at multi-function input terminal S1.
EoF	Emergency Override Forward Run
Eor	Emergency Override Reverse Run
E5	SI-T3 Watchdog Timer Error
	The watchdog timed out.
FAn	Internal Fan Error
	Fan or magnetic contactor failure
Feedback Loss Go To Freq. b5-13	PI Feedback Loss
	The drive will run at the speed set in b5-13, Feedback Loss Goto Frequency.
Feedback Loss Wire Break	PI Feedback Loss
	The analog input programmed for PID feedback has gone above 21 mA or fallen below 3 mA.
Freq. Ref Pump Min (P1-06)	Minimum Pump Frequency Reference
	Drive frequency reference is set lower than P1-06, Minimum Pump Frequency.
Freq. Ref Thrust (P4-12)	Thrust Frequency Reference
	The fixed frequency reference is set to a value lower than the P4-12, Thrust Frequency, setting.
Geo Params Chk Q2-05 to Q2-08	Geothermal Mode Parameters
	The drive is running at the level set in Q2-03 due to an incorrect setting.
HCA	Current Alarm
	Drive current exceeded overcurrent warning level (150% of the rated current).
HIAUX High PI Aux Lvl	High PI Auxiliary Feedback Level
HIFLO High Flow	High Flow Error
	The meter has detected a high flow condition.
High Feedback High FB Sensed	High Feedback Level Alarm
	The feedback signal is too high.
HISUC High Suction	High Section Pressure
LOAUX Low PI Aux Lvl	Low PI Auxiliary Feedback Level
LOP	Loss of Prime
	The pump has lost its prime and P1-22 is set to 1.
LOSUC Low Suction	Low Section Pressure
Low City Pressure	Low City Pressure
Low Feedback Low FB Sensed	Low Feedback Level Alarm
	The feedback signal is too low.
Low Suction Pressure	Low Suction Pressure

i.6 Troubleshooting

HOA Keypad Display	Alarm Name
Low Water in Tank	Low Water in Tank
Low WL/SP/PI-Aux Drive Disabled	Low Water Level / Suction Pressure / Aux PI Feedback Disabled
	Water Level or Suction Pressure is below the Q4-06/Q5-06/Q6-06 setting.
LT-1	Cooling Fan Maintenance Time
	The cooling fan has reached its expected maintenance period and may need to be replaced. Note: An alarm output (H2-□□ = 10) will only be triggered if both (H2-□□ = 2F and H2-□□ = 10) are set.
LT-2	Capacitor Maintenance Time
	The main circuit and control circuit capacitors are nearing the end of their expected performance life. Note: An alarm output (H2-□□ = 10) will only be triggered if H2-□□ = 2F.
LT-3	Soft Charge Bypass Relay Maintenance Time
	The DC bus soft charge relay is nearing the end of its expected performance life. Note: An alarm output (H2-□□ = 10) will only be triggered if H2-□□ = 2F.
LT-4	IGBT Maintenance Time (50%)
	IGBTs have reached 50% of their expected performance life. Note: An alarm output (H2-□□ = 10) will only be triggered if H2-□□ = 2F.
Main FdBk Lost Using Backup FB	Main PI Feedback Lost
Main FdBk Lost Using Backup FB	Main Feedback Device (H3-□□ = B) lost.
Net Flow Meter Lost, Chk Source	Net Flow Meter Loss
	There is no drive on the MEMOBUS network with an analog flow meter.
NETSCAN Waiting for Master	NETSCAN
	Drive is waiting for a message from the master.
NMS	Not Maintaining Setpoint
	The setpoint cannot be maintained and P1-17 is set to 1.
oH	Heatsink Overheat
	The temperature of the heatsink exceeded the overheat pre-alarm level set to L8-02.
oH2	Drive Overheat Warning
	“Drive Overheat Warning” was input to a multi-function input terminal, S1 through S8 (H1-□□= B).
oH3	Motor Overheat
	The motor overheat signal entered to a multi-function analog input terminal exceeded the alarm level (H3-02, H3-06 or H3-10 = E).
oH5 </>	Motor Overheat (NTC Input)
	The motor temperature exceeded the level set to L1-16 (or L1-18 for motor 2)
oL1	Motor Overload
	The electronic motor overload protection tripped
oL2	Drive Overload
	The thermal sensor of the drive triggered overload protection.
oL3	Overtorque Detection 1
	The current has exceeded the value set for torque detection (L6-02) for longer than the allowable time (L6-03).
oL4	Overtorque Detection 2
	The current has exceeded the value set for Overtorque Detection 2 (L6-05) for longer than the allowable time (L6-06).
ov	DC Bus Overvoltage
	The DC bus voltage exceeded the trip point.
	<ul style="list-style-type: none"> For 200 V class drives: approximately 410 V For 400 V class drives: approximately 820 V (740 V when E1-01 is less than 400) For 600 V class drives: approximately 1040 V
PoC	Pump Over Cycle
R-DNE-S□	Remote Drive Disable

HOA Keypad Display	Alarm Name
rUn	Motor Switch during Run
	A command to switch motors was entered during run.
SE	MEMOBUS/Modbus Communication Test Mode Error
	Note: This alarm will not trigger a multi-function output terminal that is set for alarm output (H2-□□ = 10).
SPL Suction Pressure Loss	Suction Pressure Loss
	Wire-break detection for suction pressure.
THo <I>	Thermistor Disconnect
	The thermistor used to detect motor temperature has become disconnected.
TrPC	IGBT Maintenance Time (90%)
	IGBTs have reached 90% of their expected performance life.
UL3	Undertorque Detection 1
	The current has fallen below the minimum value set for torque detection (L6-02) for longer than the allowable time (L6-03).
UL4	Undertorque Detection 2
	The current has fallen below the minimum value set for torque detection (L6-05) for longer than the allowable time (L6-06).
UL6	Motor Underload
	The load has fallen below the underload curve defined in L6-14.
Uv	Undervoltage
	One of the following conditions was true when the drive was stopped and a Run command was entered: <ul style="list-style-type: none"> • DC bus voltage dropped below the level specified in L2-05. • Contactor to suppress inrush current in the drive was opened. • Low voltage in the control drive input power. This alarm outputs only if L2-01 is not 0 and DC bus voltage is under L2-05.
voF	Output Voltage Detection Error
	Problem detected with the voltage on the output side of the drive.
WLL Water Level Loss	Water Level Loss
WL/SP/PIAux Lost Switched to Net	Analog Water Level / Suction Pressure / Aux PI Feedback Lost
	Network Water Level / Suction Pressure / Aux PI Feedback is now being used because a wire-break was detected with the analog signal. Water Level Analog Input Wire Break (WL Wire Break) is effective when Q4-16 is set to 1 (Alarm) or 2 (Fault). Suction Pressure Analog Input Wire Break (SP Wire Break) is effective when Q5-19 is set to 1 (Alarm) or 2 (Fault).
WrUn	Waiting for Run

<I> Detected in models 4A0930 and 4A1200.

◆ Operator Programming Errors

■ oPE Codes

An Operator Programming Error (oPE) occurs when a contradictory parameter is set or an individual parameter is set to an inappropriate value.

The drive will not operate until the parameter or parameters causing the problem are set correctly. An oPE, however, does not trigger an alarm or fault output. When an oPE appears on the operator display, press the ENTER button to view U1-18 and see which parameter is causing the oPE.

HOA Keypad Display	Error Name
oPE01	Drive Capacity Setting Fault
	Drive capacity and the value set to o2-04 do not match.
oPE02	Parameter Range Setting Error
	Use U1-18 to find parameters set outside the range.
oPE03	Multi-Function Input Selection Error
	A contradictory setting is assigned to multi-function contact inputs H1-01 to H1-08.
oPE04	Initialization Required, Term <-> Ctrl Chg

i.6 Troubleshooting

HOA Keypad Display	Error Name
oPE05	Run Command/Frequency Reference Source Selection Error
oPE07	Multi-Function Analog Input Selection Error
	A contradictory setting is assigned to multi-function analog inputs H3-02, H3-10, or H3-06 and PID functions conflict.
oPE09	PID Control Selection Fault
	PID control function selection is incorrect. Requires that PID control is enabled (b5-01 = 1 to 4).
oPE10	V/f Data Setting Error
	One of the following setting errors has occurred: E1-09 ≤ E1-07 < E1-06 ≤ E1-11 ≤ E1-04
oPE11	Carrier Frequency Setting Error
	Correct the setting for the carrier frequency.
oPE18	Online Tuning Parameter Setting Error
	Parameters controlling online tuning are not set correctly.
oPE28	Sequence Timer Error
	One or more of the sequence timers is not set in the correct order.
oPE29	Geothermal Set Error
oPE30	Flow Meter Input Error
oPE31	Water Level/Suction Pressure/PI Aux
oPE32	Incompatible Network Water Level/Suction Pressure Mode
oPE33	Parameter selection is incompatible with the selected network P9-99
oPE34 DeScale Set Err	De-Scale Setting Error

◆ Auto-Tuning Errors

■ Auto-Tuning Codes

Auto-Tuning faults in this section are displayed on the digital operator and will cause the motor to coast to a stop. Auto-Tuning faults do not trigger a multi-function digital output set for fault or alarm output.

An End□ error on the digital operator display indicates Auto-Tuning has successfully completed with discrepancies in the calculations. Restart Auto-Tuning after fixing the cause of the End□ error.

The drive may be used in the application if no cause can be identified despite the existence of an End□ error.

An Er□ error indicates that Auto-Tuning has not completed successfully. Check for the cause of the error using the tables in this section, and perform Auto-Tuning again after fixing the cause.

HOA Keypad Display	Error Name
End1	Excessive V/f Setting (detected only during Rotational Auto-Tuning and displayed after Auto-Tuning is complete)
End2	Motor Iron-Core Saturation Coefficient (detected only during Rotational Auto-Tuning and displayed after Auto-Tuning is complete)
End3	Rated Current Setting Alarm (displayed after Auto-Tuning is complete)
End4	Adjusted Slip Calculation Error
End5	Resistance Tuning Error
End6	Leakage Inductance Alarm
End7	No-Load Current Alarm
Er-01	Motor Data Error
Er-02	Minor Fault
Er-03	STOP Button Input
Er-04	Line-to-Line Resistance Error
Er-05	No-Load Current Error
Er-08	Rated Slip Error
Er-09	Acceleration Error
Er-11	Motor Speed Fault
Er-12	Current Detection Error

HOA Keypad Display	Error Name
Er-13	Leakage Inductance Error
Er-17	Reverse Prohibited Error

◆ Copy Function Related Displays

HOA Keypad Display	Error Name
CoPy	Writing Parameter Settings (flashing)
CPyE	Error Writing Data
CSEr	Copy Unit Error
dFPS	Drive Model Mismatch
End	Task Complete
iFEr	Communication Error
ndAT	Model, Voltage Class, Capacity Mismatch
rdEr	Error Reading Data
rEAd	Reading Parameter Settings (flashing)
vAEr	Voltage Class, Capacity Mismatch
vFyE	Parameter settings in the drive and those saved to the copy function are not the same
vrFy	Comparing Parameter Settings (flashing)

◆ HOA Keypad Display Messages

Table i.24 lists messages and errors that may appear during normal pump operation.

These messages do not trigger multi-function output terminals that have been set up to close when a fault or alarm occurs.

Table i.24 HOA Keypad Display Messages

HOA Keypad Display	Description
Anti Jam Active	Displayed when the drive is performing the anti-jam function.
CrST Cannot Reset	Fault reset was being executed when a Run command was entered. Ensure that a Run command cannot be entered from the external terminals or option during fault reset. Turn off the Run command.
De-staging in X sec	Displayed during multiplexing when either a drive or contactor de-staging is in progress. X sec indicates the time left before the de-staging takes place.
DigitalOut Delay Active	Displayed when the Digital Output Delay function is active.
Feedback Drop Check	Displayed when the drive is determining whether the feedback will change abruptly when the drive enters Sleep Mode. Drop Level is configured by P2-08, Delta Sleep Feedback Drop Level, and P2-09 Feedback Detection Drop Time.
Freq Reduction Active (P3-07)	Maximum Frequency temporarily reduced due to Staging.
LOCK Parameter Locked	Displayed after an attempt to change a parameter when A1-01 = 3. Unlock the keypad by setting A1-01 = 2.
Lube Pump Active	Displayed when the Lube Pump digital output is energized.
Net Geothm Tmp Lost, Chk Source	Displayed when no valid analog Geothermal Temperature source can be found on the network.
Net Pump Err Chk Faulted Pump	Displayed when the drive has been stopped because another drive in the network has a system fault or a Low City Pressure alarm.
Net Start Delay P9-29 Active	Displayed when the MEMOBUS network is waiting for the P9-29 timer to elapse.
Net WtrLvl/SucPr or PIAuxFB Lost	Displayed when the network source for Water Level, Suction Control Pressure, or Aux PI Feedback has been lost. Valid analog source for Water Level, Suction Control Pressure, or Aux PI Feedback cannot be found on the network. Check the source on drives configured as P9-50 ≠ 3.
Network FB Lost Check FB Source	Displayed when no valid analog PI feedback source can be found on the network and network PI feedback has been lost.
PASS MEMOBUS/Modbus Comm. Test Mode Complete	MEMOBUS/Modbus test has finished normally.
Pre Chg Mode Exit in Xsec	Pre-charge 1 or 2 active. X indicates time left before pre-charge exits due to timers (P4-03 + P4-07).

i.6 Troubleshooting

HOA Keypad Display	Description
Primer Pump Active </>	The drive is delaying the start of the motor and the Primer Pump (H2-□□ = 8B) digital output is energized.
ScreenMtrStarter Active </>	The drive is delaying the start of the motor and the Screen Motor Starter (H2-□□ = 8B) digital output is energized.
Setpoint Boost Active (P3-11)	Maximum Frequency temporarily reduced due to Staging.
Single Phase Foldback	Displayed when an input phase has been lost, or when excess load is being drawn by the motor in a single phase application.
Sleep Active Min/Max PIAuxLvl </>	Displayed when the PI Aux Feedback falls below the Q6-04/Q6-24 level for longer than the Q6-05 time forcing the drive to go to a sleep condition.
Sleep Active Min Suction Pres	Displayed when the drive has gone to sleep because the suction level has dropped below the level set in Q5-04 for longer than the time set in Q5-05.
Sleep Active Min Water Level	Displayed when the drive has gone to sleep because the water level has dropped below the level set in Q4-04 for longer than the time set in Q4-05.
Sleep Active Wait for Start	Displayed when the drive is in Sleep Mode or when the drive is waiting for the feedback level to reach the level set in P1-04, Start Level.
Sleep AUTO -> Off AUTO Cmd to RUN </>	Displayed when parameter P2-15 is set to 1 (Enabled) and drive has turned-off due to Sleep..
Sleep Boost Active	Displayed when the drive entering Sleep Mode and the pressure setpoint is being boosted. During this time, the U1-01, Frequency Reference, monitor will be updated with the boosted setpoint.
Staging in X sec	Displayed during multiplexing when either a drive or contactor staging is in progress. X sec indicates the time left before the staging takes place.
Start Delay Adjust b1-11	Displayed when the drive start is being delayed by Coast to Stop with Timer (Back Spin Timer). This time is adjusted by parameter b1-11, Coast to Stop with Timer Time.
Start Delay Timer Active	Displayed when the feedback level has reached the level set in P1-04, Start Level, and the Start Delay timer is incrementing.
Thrust Mode Thrust Active	Displayed during Thrust Mode.
Utility Delay Adjust by P4-17	Displayed when the drive is delaying the Run command due to the Utility Start Delay Function.

</> Available in drive software versions PRG: 8552 and later. Not available in drive models 4A0930 and 4A1200.

◆ Fault Reset Methods

When a fault occurs, the cause of the fault must be removed and the drive must be restarted. The table below lists the different ways to restart the drive.

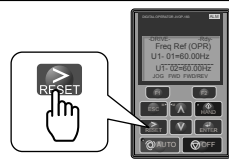
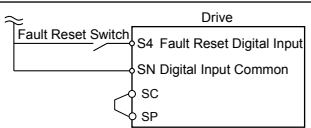
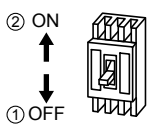
After the Fault Occurs	Procedure	
Fix the cause of the fault, restart the drive, and reset the fault	Press  on the HOA keypad.	
Resetting via a multi-function digital input programmed for Fault Reset (H1-□□ = 14).	For example, close then open the fault signal digital input via terminal S4. S4 is set for “Fault Reset” as default (H1-04 = 14).	
Turn off the main power supply if the above methods do not reset the fault. Reapply power after the HOA keypad display has turned off. When an “SC” error occurs, contact Yaskawa or a Yaskawa agent before cycling the power to the drive.		

Note: If the Run command is present, the drive will disregard any attempts to reset the fault. Remove the Run command before attempting to clear a fault situation.

i.7 Drive Specifications

- Note:**
1. Perform rotational Auto-Tuning to obtain the performance specifications given below.
 2. For optimum performance life of the drive, install the drive in an environment that meets the required specifications.

	Item	Specification
Control Characteristics	Control Method	The following control methods can be set using drive parameters: <ul style="list-style-type: none"> • V/f Control (V/f) • Open Loop Vector Control (OLV)
	Frequency Control Range	0.01 to 400 Hz
	Frequency Accuracy (Temperature Fluctuation)	Digital input: within $\pm 0.01\%$ of the max output frequency (-10 to +40 °C) Analog input: within $\pm 0.1\%$ of the max output frequency (25 °C ± 10 °C)
	Frequency Setting Resolution	Digital inputs: 0.01 Hz Analog inputs: 1/2048 of the maximum output frequency setting (11 bit plus sign) Resolution of analog inputs A1 and A3 is 10 bit + sign in current mode
	Output Frequency Resolution	0.001 Hz
	Frequency Setting Signal	Main speed frequency reference: DC -10 to +10 V (20 k Ω), DC 0 to +10 V (20 k Ω), 4 to 20 mA (250 Ω), 0 to 20 mA (250 Ω) Main speed reference: Pulse train input (max. 32 kHz)
	Starting Torque </>	V/f: 150% at 3 Hz OLV: 200% at 0.3 Hz
	Speed Control Range </>	V/f: 1:40 OLV: 1:200
	Speed Control Accuracy </>	OLV: $\pm 0.2\%$ (25 °C ± 10 °C)
	Speed Response </>	OLV
	Torque Limit	Parameters setting allow separate limits in four quadrants (available in OLV)
	Accel/Decel Time	0.0 to 6000.0 s (2 selectable combinations of independent acceleration and deceleration settings)
	Braking Torque	Approx. 20% (approx. 125% when using braking resistor) </> <ul style="list-style-type: none"> • Short-time decel torque </> : over 100% for 0.4/ 0.75 kW motors, over 50% for 1.5 kW motors, and over 20% for 2.2 kW and above motors </> (overexcitation braking/High Slip Braking: approx. 40%) • Continuous regenerative torque: approx. 20% </> (approx. 125% with dynamic braking resistor option </> : 10% ED, 10s)
	Braking Transistor	Models 2A0004 to 2A0138, 4A0002 to 4A0072, and 5A0003 to 5A0052 have a built-in braking transistor.
	V/f Characteristics	User-selected programs and V/f preset patterns possible
Main Control Functions	Momentary Power Loss Ride-Thru, Speed Search, Overtorque/Undertorque Detection, Torque Limit, 17 Step Speed (max), Accel/decel Switch, S-curve Accel/decel, 3-wire Sequence, Auto-tuning (rotational, stationary tuning), Dwell, Cooling Fan on/off Switch, Slip Compensation, Frequency Jump, Upper/lower Limits for Frequency Reference, DC Injection Braking at Start and Stop, Overexcitation Braking, High Slip Braking, PID Control (with sleep function), Energy Saving Control, MEMOBUS/Modbus Comm. (RS-422/RS-485 max, 115.2 kbps), Fault Restart, Application Presets, DriveWorksEZ (customized function), Removable Terminal Block with Parameter Backup Function, Online Tuning, KEB, Overexcitation Deceleration, Overvoltage Suppression, Dynamic Noise Control.	
Protection Functions	Motor Protection	Electronic thermal overload relay
	Momentary Overcurrent Protection	Drive stops when output current exceeds 170% of rated output current
	Overload Protection	Drive stops when rated output current is 120% for 60 s </>
	Overvoltage Protection	200 V class: Stops when DC bus voltage exceeds approx. 410 V 400 V class: Stops when DC bus voltage exceeds approx. 820 V 600 V class: Stops when DC bus voltage exceeds approx. 1040 V
	Undervoltage Protection	200 V class: Stops when DC bus voltage falls below approx. 190 V 400 V class: Stops when DC bus voltage falls below approx. 380 V 600 V class: Stops when DC bus voltage falls below approx. 475 V

i.7 Drive Specifications

Item		Specification
Protection Functions	Momentary Power Loss Ride-Thru	Immediately stop after 15 ms or longer power loss <6> . Continuous operation during power loss than 2 s (standard) <7>
	Heatsink Overheat Protection	Thermistor
	Braking Resistor Overheat Protection	Overheat input signal for braking resistor (Optional ERF-type, 3% ED)
	Stall Prevention	Stall Prevention is available during acceleration, deceleration, and during run.
	Ground Protection	Electronic circuit protection <8>
	DC Bus Charge LED	Remains lit until DC bus voltage falls below 50 V
Environment	Area of Use	Indoors
	Ambient Temperature	-10 to +40 °C (IP20/NEMA 1, UL Type 1 enclosure), -10 to +50 °C (IP00/Open Type enclosure)
	Humidity	95 RH% or less (no condensation)
	Storage Temperature	-20 to +60 °C (short-term temperature during transportation)
	Altitude	Up to 1000 meters without derating, up to 3000 m with output current and voltage derating.
	Vibration/Shock	10 to 20 Hz: 9.8 m/s ² <9> 20 to 55 Hz: 5.9 m/s ² (2A0004 to 2A0211, 4A0002 to 4A0165, and 5A0003 to 5A0099) 2.0 m/s ² (2A0250 to 2A0415, 4A0208 to 4A1200, and 5A0125 to 5A0242)
Safety Standard		UL 508C (Power Conversion), UL/cUL listed, CSA 22.2 No. 14-05 (Industrial Control Equipment), CE marked, RoHS compliant, EN 61800-5-1 (LVD), EN 61800-3 (EMC), IEC60529
Protection Design		IP00/Open Type enclosure, IP20/NEMA 1, UL Type 1 enclosure <10>

- <1> The accuracy of these values depends on motor characteristics, ambient conditions, and drive settings. Specifications may vary with different motors and with changing motor temperature. Contact Yaskawa for consultation.
- <2> Disable Stall Prevention during deceleration (L3-04 = 0) when using a regenerative converter, a regenerative unit, a braking resistor or the Braking Resistor Unit. The default setting for the Stall Prevention function will interfere with the braking resistor.
- <3> Instantaneous average deceleration torque refers to the torque required to decelerate the motor (uncoupled from the load) from the rated motor speed down to zero in the shortest time.
- <4> Actual specifications may vary depending on motor characteristics.
- <5> Overload protection may be triggered when operating with 150% of the rated output current if the output frequency is less than 6 Hz.
- <6> May be shorter due to load conditions and motor speed.
- <7> A separate Momentary Power Loss Ride-Thru Unit is required for models 2A0004 to 2A0056 and 4A0002 to 4A0031 if the application needs to continue running for up to 2 seconds during a momentary power loss.
- <8> Ground protection cannot be provided when the impedance of the ground fault path is too low, or when the drive is powered up while a ground fault is present at the output.
- <9> Models 4A0930 and 4A1200 are rated at 5.9 m/s².
- <10> Removing the top protective cover or bottom conduit bracket from an IP20/NEMA 1, UL Type 1 enclosure drive voids NEMA 1, UL Type 1 protection while maintaining IP20 conformity. This is applicable to models 2A0004 to 2A0211, 4A0002 to 4A0165, and 5A0003 to 5A0242.

i.8 Parameter Table

This parameter table shows the most important parameters. Default settings are in **bold type**. Refer to the User Manual for a complete list of parameters.

No.	Name	Description	No.	Name	Description
A1-00	Language Selection	0: English 1: Japanese 2: German 3: French 4: Italian 5: Spanish 6: Portuguese	b1-02	Run Command Selection 1	0: HOA keypad 1: Digital input terminals 2: MEMOBUS/Modbus communications 3: Option PCB 6: AUTOKey + Term 7: AUTOKey + Serial 8: AUTOKey + Option
A1-01	Access Level Selection	0: View and set A1-01 and A1-04. U□-□□ parameters can also be viewed. 1: User Parameters (access to parameters selected by the user, A2-01 to A2-32) 2: Advanced Access (access to view and set all parameters) 3: Lock parameters	b1-03	Stopping Method Selection	0: Ramp to stop 1: Coast to stop 2: DC Injection Braking to stop 3: Coast with timer
A1-02	Control Method Selection	0: V/f Control 2: Open Loop Vector Control	b1-11	Run Delay at Stop (Back Spin Timer)	Sets the amount of time that the drive will disallow the reapplication of the Run command after the Run command is lost. b1-11 is active for all b1-03 settings. If set to zero and b1-03 = 3 (Coast to Stop w/ Timer), a combination of C1-02 and output frequency determine the length of time. Otherwise, no run delay will be applied.
A1-03	Initialize Parameters	0: No initialization 1110: User Initialize (parameter values must be stored using parameter o2-03) 2220: 2-Wire initialization 3330: 3-Wire initialization 5550: Terminal->Control Initialize 6008: Pressure Control 6009: Pump down level 6010: Geothermal mode 6011: VTC pressure control 6012: Pivot Panel VTC 6013: Advanced Pressure Control 6014: Pivot Panel Submersible 6015: VTC Pump Command 6016: Sub Pump Command 7770: General purpose 7771: Submersible Motor General Purpose Note: A1-03 is initially set to "6008" from the factory, although the keypad will always display "0".	b1-12	Run Delay Memory Selection	Determines whether the Run Delay Timer is saved to the EEPROM during power loss. 0: Disabled 1: Only at Stop 2: Running & Stop Note: A JVOP-183 HOA Keypad must be plugged into the drive for settings 1 and 2 to function. If the keypad is removed, b1-12 will function as setting 0 (Disabled).
A1-04	Enter Password	When the value set into A1-04 does not match the value set into A1-05, parameters A1-01 through A1-03 and A2-01 through A2-33 cannot be changed.	b1-14	Phase Order Selection	0: Standard 1: Switch phase order (reverses the direction of the motor)
A1-05	Select Password		b1-15	Frequency Reference Selection 2	0: Operator 1: Analog Input 2: Serial Communications 3: Option PCB 4: Pulse Input
A1-06	Application Preset	Note: This parameter is not settable. It is used as a monitor only. 0: Pressure Control 1: General Purpose 2: Sub Mtr GP Oper 3: VTC Pump Command 4: Sub Pump Command 5: General Ext HOA 6: General HOA Keys 8: Pressure Control 9: Pump Down Level 10: Geothermal Mode 11: VTC Pressure Ctl 12: Pivot Panel VTC 13: Adv PressureCtrl 14: Pivot Panel Sub	b1-16	Run Command Selection 2 Run Source 2	0: Operator 1: Digital Inputs 2: Communication 3: Option PCB 6: AUTOKey + Term 7: AUTOKey + Serial 8: AUTOKey + Option
b1-01	Frequency Reference Selection 1	0: HOA keypad 1: Analog input terminals 2: MEMOBUS/Modbus communications 3: Option PCB 4: Pulse input (terminal RP) 5: Geothermal Mode (Frequency reference dependent on temperature input (H3-0□ = 21)	b1-17	Run Command at Power Up	0: Disregarded. A new Run command must be issued after power up. 1: Allowed. Motor will start immediately after power up if a Run command is already enabled.
			b5-01	PID Function Setting	0: Disabled 1: Enabled (PID output becomes output frequency reference, deviation D controlled)
			b5-02	Proportional Gain Setting (P)	Sets the proportional gain of the PID controller.
			b5-03	Integral Time Setting (I)	Sets the integral time for the PID controller.
			b5-06	PID Output Limit	Sets the maximum output possible from the entire PID controller as a percentage of the maximum output frequency.

i.8 Parameter Table

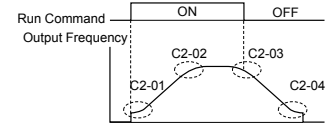
No.	Name	Description
b5-07	PID Offset Adjustment	Applies an offset to the PID controller output. Set as a percentage of the maximum output frequency.
b5-12	Feedback Loss 4 to 20 mA Detection Selection	0: Disabled 1: Alarm only 2: Fault 3: Run at b5-13
b5-13	Feedback Loss Goto Frequency	Sets the speed at which the drive will run if a 4 to 20 mA wire break is detected on the PID Feedback and when b5-12 is set to 3 (Run at b5-13).
b5-14	Feedback Loss of Prime Level	Detects loss of prime in the pump when a wire break condition has occurred.
b5-15	Feedback Loss Go To Frequency Time Out	When b5-12 = 3 and the Feedback signal is lost, the drive will run at the b5-13 speed for the b5-15 time, after which the drive will fault on Feedback Loss (FDBKL).
b5-16	Feedback Loss Start Delay	When an AUTO Run command is initiated, the drive will not fault on Feedback Loss (FDBKL) or use the Feedback Loss GoTo Frequency (b5-13) until the b5-16 time has expired.
b5-32	Integrator Ramp Limit	When set to a value greater than zero, the PI Integrator is forced to be within +/- this amount of the soft starter output.
b5-39	PID Setpoint Display Digits	0: No decimal places 1: One decimal place 2: Two decimal places 3: Three decimal places
C1-01	Acceleration Time 1	Sets the time to accelerate from 0 to maximum frequency.
C1-02	Deceleration Time 1	Sets the time to decelerate from maximum frequency to 0.
C1-03	Acceleration Time 2	Sets the time to accelerate from 0 to maximum frequency.
C1-04	Deceleration Time 2	Sets the time to decelerate from maximum frequency to 0.
C2-01	S-Curve Characteristic at Accel Start	<p>The S-curve can be controlled at the four points shown below.</p> 
C2-02	S-Curve Characteristic at Accel End	
C2-03	S-Curve Characteristic at Decel Start	
C2-04	S-Curve Characteristic at Decel End	
C6-02	Carrier Frequency Selection	1: 2.0 kHz 2: 5.0 kHz (4.0 kHz) 3: 8.0 kHz (6.0 kHz) 4: 10.0 kHz (8.0 kHz) 5: 12.5 kHz (10.0 kHz) 6: 15.0 kHz (12.0 kHz) 7: Swing PWM1 (1.5 to 2.5 kHz Random) 8: Swing PWM2 (1.0 to 3.0 kHz Random) 9: Swing PWM3 (1.5 to 2.5 kHz Sinusoidal) A: Swing PWM4 (1.5 to 2.5 kHz Sinusoidal) B to E: No setting possible F: User-defined (determined by C6-03 through C6-05)
d1-01 to d1-16	Frequency Reference 1 to 16	Sets the frequency reference for the drive. Setting units are determined by parameter o1-03.
d1-17	Jog Frequency Reference	Sets the Jog frequency reference. Setting units are determined by parameter o1-03.
d2-01	Frequency Reference Upper Limit	Sets the frequency reference upper limit as a percentage of the maximum output frequency.

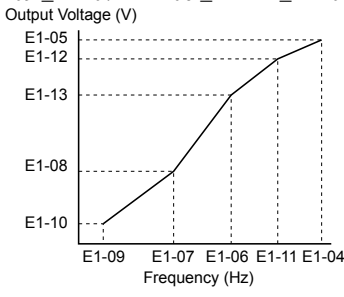
No.	Name	Description
d2-02	Frequency Reference Lower Limit	Sets the frequency reference lower limit as a percentage of the maximum output frequency.
d2-03	Master Speed Reference Lower Limit	Sets the lower limit for frequency references from analog inputs as a percentage of the maximum output frequency.
d3-01 to d3-03	Jump Frequency 1 to 3	Eliminates problems with resonant vibration of the motor/machine by avoiding continuous operation in predefined frequency ranges. The drive accelerates and decelerates the motor through the prohibited frequency ranges. Parameters must be set so that $d3-01 \geq d3-02 \geq d3-03$.
d3-04	Jump Frequency Width	Sets the dead-band width around each selected prohibited frequency reference point.
E1-01	Input Voltage Setting	<p>This parameter must be set to the power supply voltage.</p> <p>WARNING! Electrical Shock Hazard. Drive input voltage (not motor voltage) must be set in E1-01 for the protective features of the drive to function properly. Failure to do so may result in equipment damage and/or death or personal injury.</p>
E1-03	V/f Pattern Selection	0: 50 Hz, Constant torque 1 1: 60 Hz, Constant torque 2 2: 60 Hz, Constant torque 3 (50 Hz base) 3: 72 Hz, Constant torque 4 (60 Hz base) 4: 50 Hz, Variable torque 1 5: 50 Hz, Variable torque 2 6: 60 Hz, Variable torque 3 7: 60 Hz, Variable torque 4 8: 50 Hz, High starting torque 1 9: 50 Hz, High starting torque 2 A: 60 Hz, High starting torque 3 B: 60 Hz, High starting torque 4 C: 90 Hz (60 Hz base) D: 120 Hz (60 Hz base) E: 180 Hz (60 Hz base) F: Custom V/f, E1-04 through E1-13 settings define the V/f pattern
E1-04	Maximum Output Frequency	These parameters are only applicable when E1-03 is set to F.
E1-05	Maximum Voltage	To set linear V/f characteristics, set the same values for E1-07 and E1-09.
E1-06	Base Frequency	In this case, the setting for E1-08 will be disregarded. Ensure that the four frequencies are set according to these rules: $E1-09 \leq E1-07 < E1-06 \leq E1-11 \leq E1-04$
E1-07	Middle Output Frequency	
E1-08	Middle Output Frequency Voltage	
E1-09	Minimum Output Frequency	
E1-10	Minimum Output Frequency Voltage	
E1-11	Middle Output Frequency 2	
E1-12	Middle Output Frequency Voltage 2	
E1-13	Base Voltage	
E2-01	Motor Rated Current	Sets the motor nameplate full load current in amps. Automatically set during Auto-Tuning.
E2-02	Motor Rated Slip	Sets the motor rated slip. Automatically set during Auto-Tuning.
E2-03	Motor No-Load Current	Sets the no-load current for the motor. Automatically set during Auto-Tuning.

No.	Name	Description	No.	Name	Description
E2-04	Number of Motor Poles	Sets the number of motor poles. Automatically set during Auto-Tuning.	H3-09	Terminal A2 Signal Level Selection	0: 0 to 10 V 1: -10 to 10 V 2: 4 to 20 mA 3: 0 to 20 mA Note: Use Jumper S1 to set input terminal A2 for a current or voltage input signal.
E2-05	Motor Line-to-Line Resistance	Sets the phase-to-phase motor resistance. Automatically set during Auto-Tuning.			
E2-06	Motor Leakage Inductance	Sets the voltage drop due to motor leakage inductance as a percentage of motor rated voltage. Automatically set during Auto-Tuning.			
E2-11	Motor Rated Power	Sets the motor rated power in kilowatts (1 HP = 0.746 kW). Automatically set during Auto-Tuning.	H3-10	Terminal A2 Function Selection	Sets the function of terminal A2.
E2-20	Motor Service Factor Amps	Sets the Motor Overload Current level for oL1 fault.	H3-11	Terminal A2 Gain Setting	Sets the level of the input value selected in H3-10 when 10 V (20 mA) is input at terminal A2.
F5-07	Terminal M1-M2 Output Selection	Sets the function for contact output terminals M1-M2.	H3-12	Terminal A2 Bias Setting	Sets the level of the input value selected in H3-10 when 0 V (0 or 4 mA) is input at terminal A2.
F5-08	Terminal M3-M4 Output Selection	Sets the function for contact output terminals M3-M4.	H3-13	Analog Input Filter Time Constant	Sets a primary delay filter time constant for terminals A1, A2, and A3. Used for noise filtering.
F5-09	DO-A3 Output Mode Selection	0: Output terminals are each assigned separate output functions. 1: Binary code output. 2: Use output terminal functions selected by parameters F5-01 through F5-08.	H3-14	Analog Input Terminal Enable Selection	Determines which analog input terminals will be enabled when a digital input programmed for "Analog input enable" (H1-□□ = C) is activated. 1: Terminal A1 only 2: Terminal A2 only 3: Terminals A1 and A2 only 4: Terminal A3 only 5: Terminals A1 and A3 6: Terminals A2 and A3 7: All terminals enabled
H1-01 to H1-08	Multi-Function Digital Input Terminals S1 to S8 Function Selection	Assigns functions to the multi-function digital inputs.			
H2-01	Terminal M1-M2 function selection (relay)	Sets the function for contact output terminals M1-M2.			
H2-02	Terminal M3-M4 function selection (relay)	Sets the function for contact output terminals M3-M4.	H3-16	Terminal A1 Offset	Adds an offset when the analog signal to terminal A1 is at 0 V.
H2-03	Terminal MD-ME-MF Function Selection	Sets the function for contact output terminals MD-ME-MF.	H3-17	Terminal A2 Offset	Adds an offset when the analog signal to terminal A2 is at 0 V.
H2-06	Watt Hour Output Unit Selection	0: 0.1 kWh units 1: 1 kWh units 2: 10 kWh units 3: 100 kWh units 4: 1000 kWh units	H3-18	Terminal A3 Offset	Adds an offset when the analog signal to terminal A3 is at 0 V.
H3-01	Terminal A1 Signal Level Selection	0: 0 to 10 V 1: -10 to 10 V 2: 4 to 20 mA 3: 0 to 20 mA Note: Use Jumper S1 to set input terminal A1 for a current or voltage input signal.	H4-01	Multi-Function Analog Output Terminal FM Monitor Selection	Selects the data to be output through multi-function analog output terminal FM. Set the desired monitor parameter to the digits available in U□-□□. For example, enter "103" for U1-03.
H3-02	Terminal A1 Function Selection	Sets the function of terminal A1.	H4-02	Multi-Function Analog Output Terminal FM Gain	Sets the signal level at terminal FM that is equal to 100% of the selected monitor value.
H3-03	Terminal A1 Gain Setting	Sets the level of the input value selected in H3-02 when 10 V is input at terminal A1.	H4-03	Multi-Function Analog Output Terminal FM Bias	Sets the signal level at terminal FM that is equal to 0% of the selected monitor value.
H3-04	Terminal A1 Bias Setting	Sets the level of the input value selected in H3-02 when 0 V is input at terminal A1.	H4-04	Multi-Function Analog Output Terminal AM Monitor Selection	Selects the data to be output through multi-function analog output terminal AM. Set the desired monitor parameter to the digits available in U□-□□. For example, enter "103" for U1-03.
H3-05	Terminal A3 Signal Level Selection	0: 0 to 10 V 1: -10 to 10 V 2: 4 to 20 mA 3: 0 to 20 mA Note: Use Jumper S1 to set input terminal A3 for a current or voltage input signal.	H4-05	Multi-Function Analog Output Terminal AM Gain	Sets the signal level at terminal AM that is equal to 100% of the selected monitor value.
H3-06	Terminal A3 Function Selection	Sets the function of terminal A3.	H4-06	Multi-Function Analog Output Terminal AM Bias	Sets the signal level at terminal AM that is equal to 0% of the selected monitor value.
H3-07	Terminal A3 Gain Setting	Sets the level of the input value selected in H3-06 when 10 V is input at terminal A3.	H4-07	Multi-Function Analog Output Terminal FM Signal Level Selection	0: 0 to 10 V 1: -10 to 10 V 2: 4 to 20 mA
H3-08	Terminal A3 Bias Setting	Sets the level of the input value selected in H3-06 when 0 V is input at terminal A3.	H4-08	Multi-Function Analog Output Terminal AM Signal Level Selection	0: 0 to 10 V 1: -10 to 10 V 2: 4 to 20 mA
			H5-01	Drive Node Address	Selects drive station node number (address) for MEMOBUS/Modbus terminals R+, R-, S+, S-. Cycle power for the setting to take effect.

i.8 Parameter Table

No.	Name	Description
H5-02	Communication Speed Selection	0: 1200 bps 1: 2400 bps 2: 4800 bps 3: 9600 bps 4: 19200 bps 5: 38400 bps 6: 57600 bps 7: 76800 bps 8: 115200 bps Cycle power for the setting to take effect.
H5-03	Communication Parity Selection	0: No parity 1: Even parity 2: Odd parity Cycle power for the setting to take effect.
H5-04	Stopping Method after Communication Error (CE)	0: Ramp to stop 1: Coast to stop 2: Fast Stop 3: Alarm only 4: Run at H5-14
H5-05	Communication Fault Detection Selection	0: Disabled 1: Enabled. If communication is lost for more than two seconds, a CE fault will occur.
H5-13	Power-up CALL Alarm	0: Disabled 1: Enabled
H6-01	Pulse Train Input Terminal RP Function Selection	0: Frequency reference 1: PID feedback value 2: PID setpoint value 5: Flow meter
H6-02	Pulse Train Input Scaling	Sets the terminal RP input signal frequency that is equal to 100% of the value selected in H6-01.
H6-03	Pulse Train Input Gain	Sets the level of the value selected in H6-01 when a frequency with the value set in H6-02 is input.
H6-04	Pulse Train Input Bias	Sets the level of the value selected in H6-01 when 0 Hz is input.
H6-05	Pulse Train Input Filter Time	Sets the pulse train input filter time constant.
H6-08	Pulse Train Input Minimum Frequency	Sets the minimum frequency for the pulse train input to be detected. Enabled when H6-01 = 0, 1, or 2.
L1-01	Motor Overload Protection Selection	0: Disabled 1: General purpose motor (standard fan cooled) 2: Drive dedicated motor with a speed range of 1:10 3: Vector motor with a speed range of 1:100 6: General purpose motor (50 Hz) The drive may not be able to provide protection when using multiple motors, even if overload is enabled in L1-01. Set L1-01 to 0 and install separate thermal relays to each motor.
L1-02	Motor Overload Protection Time	Sets the motor thermal overload protection (oL1) time.
L2-01	Momentary Power Loss Operation Selection	0: Disabled. Drive trips on Uv1 fault when power is lost. 1: Recover within the time set in L2-02. Uv1 will be detected if power loss is longer than L2-02. 2: Recover as long as CPU has power. Uv1 is not detected. 3: KEB deceleration for the time set to L2-02. 4: KEB deceleration as long as CPU has power. 5: KEB deceleration to stop.
L2-02	Momentary Power Loss Ride-Thru Time	Sets the Power Loss Ride-Thru time. Enabled only when L2-01 = 1 or 3.

No.	Name	Description
L2-03	Momentary Power Loss Minimum Baseblock Time	Sets the minimum wait time for residual motor voltage decay before the drive output reenergizes after performing Power Loss Ride-Thru. Increasing the time set to L2-03 may help if overcurrent or overvoltage occur during Speed Search or during DC Injection Braking.
L2-04	Momentary Power Loss Voltage Recovery Ramp Time	Sets the time for the output voltage to return to the preset V/f pattern during Speed Search.
L2-05	Undervoltage Detection Level (Uv1)	Sets the DC bus undervoltage trip level.
L2-06	KEB Deceleration Time	Sets the time required to decelerate from the speed when KEB was activated to zero speed.
L2-07	KEB Acceleration Time	Sets the time to accelerate to the frequency reference when momentary power loss is over. If set to 0.0, the active acceleration time is used.
L2-08	Frequency Gain at KEB Start	Sets the percentage of output frequency reduction at the beginning of deceleration when the KEB Ride-Thru function is started. Reduction = (slip frequency before KEB) × L2-08 × 2
L2-10	KEB Detection Time (Minimum KEB Time)	Sets the time to perform KEB Ride-Thru.
L2-11	DC Bus Voltage Setpoint during KEB	Sets the desired value of the DC bus voltage during KEB Ride-Thru.
L2-29	KEB Method Selection	0: Single Drive KEB Ride-Thru 1 1: Single Drive KEB Ride-Thru 2 2: System KEB Ride-Thru 1 3: System KEB Ride-Thru 2
L3-01	Stall Prevention Selection during Acceleration	0: Disabled. 1: General purpose. Acceleration is paused as long as the current is above the L3-02 setting. 2: Intelligent. Accelerate in the shortest possible time without exceeding the L3-02 level.
L3-02	Stall Prevention Level during Acceleration	Used when L3-01 = 1 or 2. 100% is equal to the drive rated current.
L3-03	Stall Prevention Limit during Acceleration	Sets Stall Prevention lower limit during acceleration when operating in the constant power range. Set as a percentage of drive rated current.
L3-04	Stall Prevention Selection during Deceleration	0: Disabled. Deceleration at the active deceleration rate. An ov fault may occur. 1: General purpose. Deceleration is paused when the DC bus voltage exceeds the Stall Prevention level. 2: Intelligent. Decelerate as fast as possible while avoiding ov faults. 3: Stall Prevention with braking resistor. Stall Prevention during deceleration is enabled in coordination with dynamic braking. 4: Overexcitation Deceleration. Decelerates while increasing the motor flux. 5: Overexcitation Deceleration 2. Adjust the deceleration rate according to the DC bus voltage.

No.	Name	Description	No.	Name	Description
L3-05	Stall Prevention Selection during Run	0: Disabled. Drive runs at a set frequency. A heavy load may cause speed loss. 1: Decel time 1. Uses the deceleration time set to C1-02 while Stall Prevention is performed. 2: Decel time 2. Uses the deceleration time set to C1-04 while Stall Prevention is performed.	L8-35	Installation Method Selection	0: IP00/Open-Chassis enclosure 1: Side-by-Side mounting 2: IP20/NEMA 1, UL Type 1 enclosure 3: Finless model drive or external heatsink installation Default setting is dependent on parameter o2-04, Drive Model Selection.
L3-06	Stall Prevention Level during Run	Enabled when L3-05 is set to 1 or 2. 100% is equal to the drive rated current.	o1-03	Digital Operator Display Selection	0: 0.01 Hz 1: 0.01% (100% = E1-04) 2: r/min (calculated using the number of motor poles setting in E2-04) 3: User-selected units (set by o1-09, o1-10 and o1-11)
L5-01	Number of Auto Restart Attempts	Sets the number of times the drive may attempt to restart after a selection of faults occur.	o1-07	Second Line Monitor Selection	Selects the monitor that is shown in the second line. Enter the last three digits of the monitor parameter number to be displayed: U□-□□. For example, set "403" to display monitor parameter U4-03. Note: Parameter is effective only when o1-06 is set to 1.
L5-02	Auto Restart Fault Output Operation Selection	0: Fault output not active. 1: Fault output active during restart attempt.	o1-08	Third Line Monitor Selection	Selects the monitor that is shown in the third line. Enter the last three digits of the monitor parameter number to be displayed: U□-□□. For example, set "403" to display monitor parameter U4-03. Note: Parameter is effective only when o1-06 is set to 1.
L5-04	Fault Reset Interval Time	Sets the amount of time to wait between performing fault restarts.	o1-09	Frequency Reference Display Units	Sets unit display for the frequency reference parameters and frequency related monitors when o1-03 = 3. 0: WC (Inch of water) 1: PSI (Pounds per square inch) 2: GPM (Gallons per minute) 3: F (Degrees Fahrenheit) 4: CFM (Cubic feet per minute) 5: CMH (Cubic meters per hour) 6: LPH (Liters per hour) 7: LPS (Liters per second) 8: Bar (Bar) 9: Pa (Pascal) 10: C (Degrees Celsius) 11: Mtr (Meters) 12: Ft (Feet) 13: LPM (Liters per minute) 14: CMM (Cubic meters per minute) 15: "Hg (inches of mercury) 24: Custom units (determined by o1-13 to o1-15) 25: None
L5-40	Low Feedback Fault Retry Selection	0: No retry 1: Retry	o2-02	STOP Key Function Selection	0: Disabled. STOP key is disabled in REMOTE operation. 1: Enabled. STOP key is always enabled.
L5-41	High Feedback Fault Retry Selection	0: No retry 1: Retry	o2-03	User Parameter Default Value	0: No change. 1: Set defaults. Saves parameter settings as default values for a User Initialization. 2: Clear all. Clears the default settings that have been saved for a User Initialization.
L5-42	Feedback Loss Fault Retry Selection	0: No retry 1: Retry	o2-04	Drive Model Selection	Enter the drive model. Setting required only if installing a new control board.
L5-50	Setpoint Not Met Retry Selection	0: No retry 1: Retry	o3-01	Copy Function Selection	0: No action 1: Read parameters from the drive, saving them onto the digital operator. 2: Copy parameters from the digital operator, writing them to the drive. 3: Verify parameter settings on the drive to check if they match the data saved on the operator.
L5-51	Loss of Prime Fault Retry Selection	0: No retry 1: Retry	P1-01	Pump Mode	0: Drive only 1: Contactor lag 3: MEMOBUS network
L5-52	Pump Over Cycle Fault Retry Selection	0: No retry 1: Retry			
L5-53	Volute-TStat Retry Selection	0: No retry 1: Retry Note: The drive will restart only after the Volute-Tstat digital input deactivates and the L5-04 timer expires.			
L8-02	Overheat Alarm Level	An overheat alarm occurs when heatsink temperature exceeds the L8-02 level.			
L8-03	Overheat Pre-Alarm Operation Selection	0: Ramp to stop. A fault is triggered. 1: Coast to stop. A fault is triggered. 2: Fast Stop. Decelerate to stop using the deceleration time in C1-09. A fault is triggered. 3: Continue operation. An alarm is triggered. 4: Continue operation at reduced speed as set in L8-19.			
L8-05	Input Phase Loss Protection Selection	0: Disabled 1: Enabled			
L8-07	Output Phase Loss Protection Selection	0: Disabled 1: Enabled (triggered by a single phase loss) 2: Enabled (triggered when two phases are lost)			
L8-09	Output Ground Fault Detection Selection	0: Disabled 1: Enabled			
L8-10	Heatsink Cooling Fan Operation Selection	0: During run only. Fan operates only during run for L8-11 seconds after stop. 1: Fan always on. Cooling fan operates whenever the drive is powered up.			
L8-11	Heatsink Cooling Fan Off Delay Time	Sets a delay time to shut off the cooling fan after the Run command is removed when L8-10 = 0.			
L8-12	Ambient Temperature Setting	Enter the ambient temperature. This value adjusts the oL2 detection level.			

i.8 Parameter Table

No.	Name	Description	No.	Name	Description
P1-02	System Units	0: No unit 1: PSI: Pounds per square inch 2: Pa: Pascals 3: Bar: Bar 4: "WC: Inch of water 5: "Hg: Inch of Mercury 6: ft: feet 7: m: meters 8: °F: Degrees Fahrenheit 9: °C: Degrees Celsius 10: Percent 11: kPA: kilopascal 25: Flow (Use P6-04) 26: Custom units	P1-14	Hysteresis Level	Sets the hysteresis level used for low and high level feedback detection.
P1-03	Feedback Device Scaling	Sets the scaling of feedback device in user-set units.	P1-15	Maximum Setpoint Difference	Sets the level that the difference between the setpoint and the feedback must exceed for the time set in P1-16 to trigger the drive response set in P1-17. If P1-17 is set to 1 (Fault and digital out), the drive will coast to stop. This function is active when the drive is running during AUTO Mode. When P1-01 is set to 3 (MEMOBUS network), the function is active on the lead drive and will stop all drives running on the network when The NMS fault occurs. Setting this parameter to 0.0 disables the function.
P1-04	Start / Draw Down Level	The system starts when the feedback level drops below the start level for the time set in P1-05. This level also specifies the wake-up level when the drive is in Sleep Mode. When this parameter is set to a negative value, the feedback level must drop that amount below the setpoint. Setting this parameter to 0.0 disables the function. When P1-01, Pump Mode, is set to 3 (MEMOBUS network), this function is active only on the first drive in the network. Note: When PID operates in reverse mode, the system will start when the feedback has risen above the start level for the time set to P1-05.	P1-16	Not Maintaining Setpoint Time	Sets the delay time before a "Setpoint Not Met" condition occurs. The pump protection criteria set in P1-15 must be met before the timer will start. Setting P1-15 to 0.0 disables this function.
P1-05	Start Level Delay Time	The system starts when the feedback level drops below the start level for the time set in this parameter.	P1-17	Not Maintaining Setpoint Selection	0: Fault 1: Alarm 2: Digital out only
P1-06	Minimum Pump Speed	Minimum frequency at which the drive will run. Applies to both HAND and Automatic modes. Note: For minimum pump frequency, the drive will use the highest setting from among P1-06, P4-12 (Thrust Bearing Frequency), or d2-02 (Reference Lower Limit).	P1-18	Prime Loss Detection Method	0: Current (A) 1: Power (kW) 2: Torque (%)
P1-07	Minimum Pump Speed Units	0: Hz 1: RPM Note: Changing this parameter will reset the P1-06 default value.	P1-19	Prime Loss Level	Detects loss of prime in the pump when in Auto or Sleep Boost Mode. When the measured quantity determined by P1-18 drops below this level for the time set in P1-20 and the output frequency is above the level set in P1-21, a "Loss of Prime" condition occurs. The drive responds to the "Loss of Prime" condition depending on the setting of P1-22, Loss of Prime Selection.
P1-08	Low Feedback Level	Sets the lower detection level for the PID feedback.	P1-20	Loss of Prime Time	Sets the delay time before a "Loss of Prime" condition occurs. The pump protection criteria set in P1-18 and P1-19 must be met before the timer will start.
P1-09	Low Feedback Level Fault Delay Time	Sets the amount of delay time from when the low feedback is detected until the drive faults on an "LFB Low Feedback" fault.	P1-21	Loss of Prime Frequency	Sets the frequency level above which the "Loss of Prime" detection is enabled when set to a value other than 0. When set to 0 (default), the frequency level is determined by the smaller value between (Fmax - 1 Hz) and (d2-01 - 1 Hz).
P1-10	Low Feedback Selection	0: Fault 1: Alarm 2: Digital out only	P1-22	Loss of Prime Selection	0: Fault 1: Alarm 2: Digital out only
P1-11	High Feedback Level	Sets the upper detection level for the PID feedback.	P1-23	Loss of Prime Maximum Restart Time after Fault	Sets the time in minutes that the drive will wait before attempting another restart when the restart fails or is not attempted due to a continuing fault condition.
P1-12	High Feedback Level Fault Delay Time	Sets the amount of delay time from when the high feedback is detected until the drive faults on a "HFB High Feedback" fault. Note: This parameter is effective only when P1-13 is set to 0 (Fault (and digital out)).	P1-30	Low Water Digital Input Configuration	0: Normally open 1: Normally closed
P1-13	High Feedback Selection	0: Fault 1: Alarm 2: Digital out only	P1-31	High Water Digital Input Configuration	0: Normally open 1: Normally closed
			P1-32	System Units Custom 1st Character	Sets the first character of the custom unit display when P1-02 = 26.
			P1-33	System Units Custom 2nd Character	Sets the second character of the custom unit display when P1-02 = 26.
			P1-34	System Units Custom 3rd Character	Sets the third character of the custom unit display when P1-02 = 26.
			P1-40	Maximum Pump Speed	Sets the maximum pump speed. This parameter does not affect operation when set to 0.0 or when set to a value higher than E1-04 x d2-01. This parameter is internally lower limited to the minimum pump speed (P1-06, P4-12, d2-02) when not set to 0.0.

No.	Name	Description	No.	Name	Description
P2-01	Sleep Level Type	<p>0: Output frequency 1: Output current 2: Feedback 3: Output speed (RPM) 4: Flow meter (requires flow meter)</p> <p>Note: Feedback depends on PID direction operation.</p>	P2-25	Anti-No-Flow Release Level	Sets the amount below the setpoint which the feedback must drop to disengage the Anti-No-Flow and return to normal PI operation.
P2-02	Sleep Level	Sleep activates when the selected level type (P2-01 setting) reaches the programmed sleep level for the time set in P2-03. This function is active when the drive is running during AUTO Mode. When P1-01 is set to 3 (MEMOBUS network), the function is active when there is only one drive running on the network. Setting this parameter below minimum pump speed (P1-06) disables Sleep Level (P2-02) and sleep activates at minimum pump speed.	P3-00	Number of Lag Pumps	Sets the number of lag pumps present.
P2-03	Sleep Delay Time	Sets the delay time before the drive enters Sleep Mode when the sleep level set in P2-02 is reached.	P3-01	Add Pump Control	<p>Selects the method for adding contactor pumps to the system.</p> <p>0: Output frequency (Uses P3-03 and P3-05) 1: Feedback (Uses P3-04 and P3-05) 2: Feedback + Fout (Uses P3-03, P3-04, and P3-05)</p>
P2-04	Sleep Activate Level	Sets the level above which the output frequency must rise to activate the sleep function when P2-01, Sleep Level Type, is set to 0 (Output Frequency / Speed). Setting this parameter to 0.0 disables the function and the sleep function will activate when P2-02, Sleep Level, is reached.	P3-02	Shutdown Pump Control	<p>Selects the method for removing contactor pumps from the system.</p> <p>0: Output frequency (Uses P3-09, P3-50 P3-60, P3-70, P3-80, and P3-90) 1: Feedback (Uses P3-08 and P3-09) 2: Feedback + Fout (Uses P3-08, P3-09, P3-50, P3-60, P3-70, P3-80, and P3-90)</p>
P2-05	Sleep Boost Level	Sets the amount of boost applied to the setpoint before going to sleep. Setting this parameter to 0.0 disables the function.	P3-03	Drive Multi/Maximum Level	<p>Sets the maximum level used for the multiplex pumping operation. Parameter is active only when P3-01 is set to 0 or 2.</p> <p>When P3-01 is set to 0, the next available pump will be added to the system by a multi-function Discrete Output closure (H2-0□ = 80 to 84) when the output frequency rises above the level set in this parameter for the time set in P3-05.</p> <p>When P3-01 is set to 2, the next available pump will be added to the system by a multi-function Discrete Output closure (H2-0□ = 80 to 84) when the output frequency rises above the level set in this parameter and the delta feedback (setpoint minus feedback) has exceeded the level programmed in P3-04 for the time set in P3-05.</p>
P2-06	Sleep Boost Hold Time	Sets the amount of time that the boosted pressure will be maintained before the drive goes to sleep.	P3-04	Add Pump Delta Level	<p>Sets the level used for the multiplex pumping operation. Parameter is active only when P3-01 is set to 1 or 2.</p> <p>When P3-01 is set to 1, the next available pump will be added to the system by a multi-function Discrete Output closure (H2-0□ = 80 to 84) when the delta feedback (setpoint minus feedback) has exceeded the level set in this parameter for the time set in P3-05.</p> <p>When P3-01 is set to 2, the next available pump will be added to the system by a multi-function Discrete Output closure (H2-0□ = 80 to 84) when the output frequency rises above the level set in P3-03 and the delta feedback (setpoint minus feedback) has exceeded the level set in this parameter for the time set in P3-05.</p> <p>Note: Programming this parameter too close to the system setpoint may cause the pump system to cycle excessively.</p>
P2-10	Sleep Mode: Cycling Protection	Sets the maximum number of cycles that are allowed within the time specified in P2-11 before tripping the PoC "Pump Over Cycle" fault. One cycle is defined when the drive transfers from normal operation in AUTO Mode to Sleep Mode. This function is active when the drive is running during AUTO Mode. When P1-01 is set to 3 (MEMOBUS network), the function is active when there is only one drive running on the network. Setting this parameter to 0 disables the function.	P3-05	Add Pump Delay Time	Sets the delay time before a pump is added to the system.
P2-11	Sleep Mode: Maximum Cycling Protection Time	Sets the maximum time allowed between cycles. When no cycling occurs within the programmed time, the drive will decrease the internal cycle register.	P3-06	Frequency Reduction after Staging	Sets the upper limit of the output frequency after a lag pump is staged. The upper limit of the output frequency is calculated by subtracting the value of this parameter from parameter P3-03. Output limit = P3-03 - P3-06
P2-12	Over Cycling Mode	<p>0: Disabled 1: Alarm 2: Fault 3: Auto SP Compensation</p>	P3-07	Frequency Reduction after Staging Time	Sets the amount of time that the output frequency will be limited after lag pump is staged.
P2-13	Setpoint Compensation	Allows for the software to automatically compensate the setpoint in the event of excessive cycling.			
P2-14	Maximum Setpoint Compensation	Sets the maximum allowed setpoint compensation for over-cycling function.			
P2-23	Anti-No-Flow Bandwidth	Sets the amount of PI error bandwidth used to detect the Anti-No-Flow condition. Avoid setting this parameter value too high, as operation may become unstable. Setting this parameter to 0.00 will disable the function.			
P2-24	Anti-No-Flow Detection Time	Sets the time delay before the drive starts the increased deceleration rate after Anti-No-Flow is detected.			

i.8 Parameter Table

No.	Name	Description
P3-08	Shutdown Pump Delta Level	<p>Sets the level used for the multiplex pumping operation. Parameter is active only when P3-02 is set to 1 or 2. When P3-02 is set to 1, the last pump that was brought online will be shut down by opening the dedicated multi-function discrete output (H2-0□ = 80 to 84) when the delta feedback (feedback minus setpoint) has exceeded the level programmed in this parameter for the time set in P3-09. When the P3-02 is set to 2, the last pump that was brought online will be shut down by opening the dedicated multi-function discrete output (H2-0□ = 80 to 84) when the output frequency drops below the level programmed in P3-50, P3-60, P3-70, P3-80, or P3-90 and the delta feedback (feedback minus setpoint) has exceeded the level set in this parameter for the time set in P3-09.</p> <p>Note: Programming this parameter too close to the system setpoint may cause the pump system to cycle excessively.</p>
P3-09	Shutdown Pump Delay Time	Sets the delay time before one of the additional line pumps is shut down.
P3-10	Setpoint Boost Maximum at De-Stage	Sets the maximum amount of boost that can be added to the setpoint after a de-stage occurs. Setting this parameter to 0.0 disables the function.
P3-11	Setpoint Boost after De-Stage Time	Sets the amount of time that the setpoint will remain boosted after lag pump is de-staged.
P3-12	Multi Pump Setpoint Increase during Transition	Sets the system setpoint increase each time a new pump is brought online. Pump 1: Setpoint Pump 1 + 2: Setpoint + P3-12 Pump 1 + 2 + 3: Setpoint + 2 x P3-12
P3-13	Multi Pump Setpoint Decrease during Transition	Sets the system setpoint decrease each time a new pump is brought online. Pump 1: Setpoint Pump 1 + 2: Setpoint - P3-13 Pump 1 + 2 + 3: Setpoint - 2 x P3-13
P3-14	Multiplex Stabilization Time	Sets the time used to stabilize the system when a pump is added or shut down during multiplex operation. When a pump is added, the stabilize timer temporarily disables the lead/lag functionality for the programmed time to prevent pump cycling. Function is active in contactor multiplex mode (P1-01 = 1). Time pump protection and lead/lag control is suspended during stabilization time.
P3-15	High Feedback Quick De-stage	Sets the High Feedback level that will trigger a quick de-stage. The quick de-stage uses an internal 2 sec delay. A setting of 0 disables this feature.
P3-16	Low Feedback Quick De-stage	Sets the Low Feedback level that will trigger a quick de-stage. The quick de-stage uses an internal 2 sec delay. A setting of 0 disables this feature.
P3-30	Stage Selection Mode	Sets the method of staging for the pumps. 0: Sequential 1: Stop history
P3-31	De-Stage Selection Mode	Sets the method for removing contactor pumps. 0: Last in, first out (LIFO) 1: First in, first out (FIFO)

No.	Name	Description
P3-40	Pre-Charge Lag Pump Select	<p>Selects which of the lag pumps can come on during a pre-charge. 0: Disabled 2: Pump 2 (H2-0□ = 80) 3: Pump 3 (H2-0□ = 81) 4: Pump 4 (H2-0□ = 82) 5: Pump 5 (H2-0□ = 83) 6: Pump 6 (H2-0□ = 84)</p>
P3-41	Pre-Charge Lag Pump Run Time	Sets the length of time that the lag pump specified in P3-40 is energized.
P3-42	Post-Pre-Charge Lag Pump Operation	Determines whether the lag pump set in pre-charge (P3-40) turns off or maintains its state when pre-charge is completed. 0: Turn off 1: Continue
P3-43	Pre-Charge Lag Pump Delay Time	Sets the length of time that the drive is in the pre-charge mode before the lag pump set in P3-40 is energized.
P3-50, P3-60, P3-70, P3-80, P3-90	Pumps 2 to 6 Frequency Shutdown Level	<p>Sets the level used for the multiplex pumping operation. Parameter is active only when P3-02 is set to 0 or 2. When P3-02 is set to 0 and a total of two pumps are running, the last pump (Pump 2) that was brought online will be shut down by opening the dedicated multi-function discrete output (H2-0□ = 80 to 84) when the output frequency falls below the level set in this parameter for the time set in P3-09. When P3-02 is set to 2 and a total of two pumps are running, the last pump (Pump 2) that was brought online will be shut down by opening the dedicated multi-function discrete output (H2-0□ = 80 to 84) when the delta feedback (setpoint minus feedback) has exceeded the level programmed in this parameter for the time set in P3-09.</p>
P4-01	Pre-Charge Level	Runs the drive at the frequency set in P4-02.
P4-02	Pre-Charge Frequency	Sets the frequency reference used when the Pre-Charge function is active.
P4-03	Pre-Charge Time	Sets the maximum allowed Pre-Charge time. When P1-01 is set to 3 (MEMOBUS network), the function is active only on the first drive to run in the network. Setting this parameter to 0.0 disables the function.
P4-04	Pre-Charge Message Style	Selects how the “Pre-charge Active” message is displayed on the operator. 0: Full Screen Message 1: Home Monitor Text
P4-05	Pre-Charge Loss of Prime Level	<p>Detects loss of prime in the pump. When the measured quantity determined by P1-18 drops below this level for the time set in P1-20 and the output frequency is at the level set in P4-02, a “Loss of Prime” condition occurs. The drive responds to the “Loss of Prime” condition depending on the setting of P1-22, Loss of Prime Selection.</p>
P4-06	Pre-Charge Frequency 2	Sets the frequency reference used when the Pre-Charge function 2 is active. Setting this parameter to 0.0 disables the function.
P4-07	Pre-Charge Time 2	Sets the time at which the drive will spend at the Pre-Charge frequency 2 speed during pre-charge. Setting this parameter to 0.0 disables the function.

No.	Name	Description	No.	Name	Description
P4-08	Pre-Charge Loss of Prime Level 2	Detects loss of prime in the pump. When the measured quantity determined by P1-18 drops below this level for the time set in P1-20 and the output frequency is at the level set in P4-06, a “Loss of Prime” condition occurs. The drive responds to the “Loss of Prime” condition depending on the setting of P1-22, Loss of Prime Selection.	P4-31	Lube Pump / Digital Output Delay Timer	Sets the amount of time to delay the drive output and to energize the digital output (H2-□□ = 8B) before the drive is allowed to run. Setting this parameter to 0.0 disables the function.
P4-10	AUTO Mode Operator Run Power Down Storage	0 : Disabled 1: Enabled	P4-32	Pre-charge Level 2	For normal PI operation during Pre-charge 2, if the PI Feedback signal rises above the P4-32 level, Pre-charge 2 is cancelled and the drive resumes normal operation. For inverse PI operation and during Pre-charge 2, if the PI Feedback signal goes below the P4-32 level, Pre-charge 2 is cancelled and the drive resumes normal operation. When set to zero, Pre-charge 2 still runs when P4-07 is set, but uses P4-01 to determine if normal operation should resume.
P4-11	Thrust Bearing Acceleration Time	Sets the time at which the drive output frequency will ramp up to the reference frequency set in P4-12.			
P4-12	Thrust Bearing Frequency	The drive will accelerate to this frequency in the time set to P4-11. The drive will decelerate from the frequency in the time set to P4-13.	P5-01	HAND Mode Ref Source	0: Analog input Note: Analog input is defaulted to input A3 (0-10 V). 1: P5-02 (HAND reference)
		WARNING! Sudden Movement Hazard. If the drive is powered down while running, it will automatically initiate an internal Run command upon power-up.	P5-02	HAND Reference 1	Sets the frequency reference used when HAND Mode is active and P5-01 is set to 1.
P4-13	Thrust Bearing Deceleration Time	Sets the amount of time it takes to bring the drive from the Thrust Frequency set in P4-12 to stop when Thrust Mode is active. When the Run command is removed while the drive is operating in Thrust Mode above the Thrust Frequency, the time set in this parameter is used when the frequency reference is at or below the thrust frequency.	P5-03	HAND/AUTO During Run Selection	0: Disabled 1: Enabled
			P5-04	HAND Key Function Selection	0: Disabled 1: Enabled
P4-14	Two Motor Alternation Selection	0: Disable 1: Enable 2: Motor 1 Only 3: Motor 2 Only	P5-05	HAND Reference 2	Sets the frequency reference used when HAND Mode 2 is active.
P4-15	Two Motor Alternation Operation Selection	0: Wait For Stop 1: Immediate (Auto mode only)	P5-06	HAND Ref. 1 Loss of Prime Level	Detects loss of prime in the pump. When the measured quantity determined by P1-18 drops below this level for the time set in P1-20 and the output frequency is at the level set in P5-02, a “Loss of Prime” condition occurs. The drive responds to the “Loss of Prime” condition depending on the setting of P1-22, Loss of Prime Selection.
P4-16	Two Motor Alternation Time	Sets the amount of time each motor will run before the drive switches to the other motor.			
P4-17	Utility Start Delay	Sets the amount of time that the drive will delay starting if a Run command is present at power-up. When P1-01, Pump Mode, is set to 3 (MEMOBUS network), the drive is unavailable to the network (Pump Off Network) when the function is active. Setting this parameter to 0.0 disables the function.	P5-07	HAND Ref. 2 Loss of Prime Level	Detects loss of prime in the pump. When the measured quantity determined by P1-18 drops below this level for the time set in P1-20 and the output frequency is at the level set in P5-05, a “Loss of Prime” condition occurs. The drive responds to the “Loss of Prime” condition depending on the setting of P1-22, Loss of Prime Selection.
P4-21	Low City Input Select	0: Normally open (closed indicates the Low City Pressure condition) 1: Normally closed (open indicates the Low City Pressure condition)			
P4-22	Low City On-Delay Time	Sets the amount of time a Low City Pressure condition needs to be present before the drive will stop.	P6-01	Flow Meter Scaling	Enables and disables flow meter functions, sets the scaling for the “Flow Rate” analog input and output, and sets the display scaling when “Flow Rate” is used as the PID feedback.
P4-23	Low City Off-Delay Time	Sets the amount of time a Low City Pressure condition needs to be absent before the drive will restart.	P6-02	Turbine Input Scaling (Coarse)	Sets the scaling for the turbine in pulses per gallon. Pulses/Gallon = P6-02 + P6-03
P4-24	Low City Alarm Text	0: Low city pressure 1: Low suction pressure 2: Low water in tank	P6-03	Turbine Input Scaling (Fine)	This parameter is internally lower-limited to 0.0001 ppG.
P4-29	Lube Pump Message Text	0: Lube Pump 1: Digital Out Delay 2: Primer Pump 3: Screen Motor Starter	P6-04	Water Flow Units	0: U.S. Gallons / min (GPM) 1: U.S. Gallons / hr (GPH) 2: Cubic Feet / min (CFM) 3: Cubic Meters / hr (CMH) 4: Acre-Feet / yr (AFY)
P4-30	Lube Pump Active During Run	0: Disabled 1: Active During Run			
			P6-25	Flow Rate Limit Foldback Message Style	Selects how the “Flow Rate Limit Foldback” message is displayed on the operator. 0: Full Screen Message 1: Home Monitor Text

i.8 Parameter Table

No.	Name	Description
P9-01	Lead Drive Selection	0: Next available 1: Lowest runtime 2: Stop history
P9-02	Feedback Source	0: Analog only 1: Ana->Net, No Alrm 2: Ana->Net, Alarm 3: Network only
P9-03	Alternation Time	Specifies the time for a drive to request alternation. Setting this parameter to 0 disables the function.
P9-04	Alternation Mode	0: FIFO auto 1: FIFO forced 2: LIFO 3: FIFO @sleep
P9-05	Lag Drive Mode	0: Fixed speed. The drive runs at the P9-06 setting after the time set in P9-07 expires. 2: Turn off. The drive stops running when it switches to a lag drive after the time set in P9-07 expires. 3: Follow Lead Speed. The drive will follow the speed of the current lead drive, applying P9-30 gain and P9-31 bias.
P9-06	Lag Fixed Speed	Sets the speed at which the drive will run when the drive changes from a lead to a lag and the time set in P9-07 has expired.
P9-07	Lag Fixed Speed Delay	Specifies how long speed is latched before performing the function specified in P9-05 when the drive changes from a lead to a lag.
P9-08	Add Pump Mode	0: Output frequency 1: Feedback 2: Feedback + Fout 3. Flow meter
P9-09	Add Frequency Level	When P9-08 is set to 0, this parameter sets the level above which the output frequency needs to rise for the time set in P9-11 before the lead drive will send a request for a new lead drive via the iQPump MEMOBUS network. When P9-08 is set to 2 and the delta feedback (setpoint minus feedback) has exceeded the level set in P9-10 for the time set in P9-11, this parameter sets the level above which the output frequency needs to rise before the lead drive will send a request for a new lead drive via the iQPump MEMOBUS network.
P9-10	Add Delta Level	When P9-08 is set to 1, this parameter sets the level above which the delta feedback (setpoint minus feedback) must rise for the time set in P9-11 before the lead drive will send a request for a new lead drive via the iQPump MEMOBUS network. When P9-08 is set to 2 and the output frequency has exceeded the level set in P9-09 for the time set in P9-11, this parameter sets the level above which the delta feedback (setpoint minus feedback) needs to rise before the lead drive will send a request for a new lead drive via the iQPump MEMOBUS network.
P9-11	Add Delay Time	Sets the delay time before a new lead drive is added to the system.
P9-12	Remove Pump Mode	0: Output frequency 1: Feedback 2: Feedback + Fout 3: Flow meter

No.	Name	Description
P9-13	Remove Frequency Level	When P9-12 is set to 0, this parameter sets the level below which the output frequency must fall for the time set in P9-15 before the lead drive will send a request to be removed from the system via the iQPump MEMOBUS network. When P9-12 is set to 2 and the delta feedback (feedback minus setpoint) has exceeded the level set in P9-14 for the time set in P9-15, this parameter sets the level below which the output frequency must fall before the lead drive will request to be removed from the system via the iQPump MEMOBUS network.
P9-14	Remove Delta Level	When P9-12 is set to 1, this parameter sets the level above which the delta feedback (feedback minus setpoint) must rise for the time set in P9-15 before the lead drive will request to be removed from the system via the iQPump MEMOBUS network. When P9-12 is set to 2 and the output frequency has exceeded the level set in P9-13 for the time set in P9-15, this parameter sets the level above which the delta feedback (feedback minus setpoint) frequency must rise before the lead drive will request to be removed from the system via the iQPump MEMOBUS network.
P9-15	Remove Delay Time	Sets the delay time before the lead drive is removed from the system.
P9-18	High Feedback Quick De-Stage	Sets the feedback level that will trigger a quick de-stage. Set as a percentage of the P1-09 value. The quick de-stage ignores parameters P9-12 to P9-15 and uses an internal 2 second delay. Setting this parameter to 0.0 disables the feature.
P9-20	Allow Network Run	0: Always 1: First/alternation 2: First only 3: Alternation only
P9-21	Run Priority	Sets the lead drive selection priority overriding the P9-01 selection. If multiple drives have the lowest P9-21 value, then P9-01 determines which drive becomes the lead.
P9-23	Maximum Number of Running Pumps	Sets the maximum number of pumps that can run on the system.
P9-24	Lead Swap at Sleep	Sets the length of time for which the lead drive will be in Sleep Mode before this drive will request a swap when there is another drive available with a lower P9-21 setting. Setting this parameter to 0 will disable the function.
P9-25	Highest Node Address	Sets the highest possible node address in the MEMOBUS network. For optimal network performance, set the serial communication address H5-01 beginning with 01h consecutively up to the last drive and then set this parameter to that H5-01 address.
Q1-01	PID Controller Setpoint 1	Sets the PID Setpoint when b1-01 is set to 0.
Q1-02	PID Controller Setpoint 2	Sets the PID Setpoint when the "Multi Setpoint 1" or "Alternate Multi Setpoint 1" multi-function digital input is closed.
Q1-03	PID Controller Setpoint 3	Sets the PID Setpoint when the "Multi Setpoint 2" or "Alternate Multi Setpoint 2" digital input is closed.

No.	Name	Description	No.	Name	Description
Q1-04	PID Controller Setpoint 4	Sets the PID Setpoint when the “Multi Setpoint 1” and “Multi Setpoint 2” or “Alternate Multi Setpoint 3” multi-function digital inputs are closed.	Q4-06	Wake-Up Water Level	Sets the level above which the water needs to rise for more than the time set in Q4-07 for the drive to wake up after being put to sleep via parameter Q4-04, Minimum Water Level.
Q3-01	Output Current Limit Select	0: Disabled 1: Enabled	Q4-07	Water Level Control Sleep Wake-Up Time	Sets the length of time that the water level set in Q4-06 must be met for the drive to wake up after being put to sleep via parameter Q4-04, Minimum Water Level.
Q3-02	Current Limit	Sets the current limit. Value is internally limited to 300% of the drive rated current.	Q5-01	Suction Pressure Select	0: Disabled 1: Suction pressure (PSI) 2: Vacuum ("Hg)
Q3-05	Current Limit Regulator Feedback Filter	First order filter time on the feedback used for Current Limit control.	Q5-02	Suction Transducer Scaling	Sets the full scale (20 mA) output of the pressure transducer that is connected to the analog input terminal programmed for “WaterLvl/Suction” (H3-0□ = 23).
Q3-06	Current Limit Foldback Message Style	Selects how the “Current Limit Foldback” message is displayed on the operator. 0: Full Screen Message 1: Home Monitor Text	Q5-03	Suction Pressure Setpoint	Sets the amount of suction pressure to which the drive will attempt to regulate.
Q3-13	Single Phase Foldback Message Style	Selects how the “Single Phase Foldback” message is displayed on the operator. 0: Full Screen Message 1: Home Monitor Text	Q5-04	Minimum Suction Pressure	Sets the level below which the suction pressure must fall for longer than the Q5-05 time to put the drive to sleep and turn off all lag pumps.
Q4-01	Water Level Selection	0: Disabled 1: Enabled	Q5-05	Suction Pressure Sleep Delay Time	Sets the length of time that the drive will delay after suction pressure drops below the level set in Q5-04 before going to sleep.
Q4-02	Water Level Scaling	Sets the full scale (20 mA) output of the pressure transducer that is connected to the analog input terminal programmed for “WaterLvl/Suction” (H3-□□ = 23). Note: 1 PSI = 2.308 feet of water	Q5-06	Wake-Up Suction Pressure	Sets the level above which the suction pressure must rise for the time set in Q5-07 for the drive to wake up when it has been put to sleep via parameter Q5-04, Minimum Suction Pressure.
Q4-03	Water Level Setpoint	Sets the amount of water above the sensor to which the drive will attempt to regulate.	Q5-07	Suction Pressure Sleep Wake-Up Time	Sets the length of time for which the pressure must rise above the level set in Q5-06 to wake up the drive when it has been put to sleep via parameter Q5-04, Minimum Suction Pressure.
Q4-04	Minimum Water Level	Sets the level below which the amount of water must drop for the time set in Q4-05 to put the drive to sleep.			
Q4-05	Water Level Sleep Delay Time	Sets the length of time that the drive will delay after the water level drops below the level set in Q4-04 before going to sleep.			

i.9 Standards Compliance

◆ European Standards



Figure i.33 CE Mark

The CE mark indicates compliance with European safety and environmental regulations. It is required for engaging in business and commerce in Europe.

European standards include the Machinery Directive for machine manufacturers, the Low Voltage Directive for electronics manufacturers, and the EMC guidelines for controlling noise.

This drive displays the CE mark based on the EMC guidelines and the Low Voltage Directive.

- **Low Voltage Directive:** 2006/95/EC
- **EMC Guidelines:** 2004/108/EC

Devices used in combination with this drive must also be CE certified and display the CE mark. When using drives displaying the CE mark in combination with other devices, it is ultimately the responsibility of the user to ensure compliance with CE standards. After setting up the device, verify that conditions meet European standards.

Note: 600 V class drives (models 5□□□□□□) are not compliant with European Standards.

◆ CE Low Voltage Directive Compliance

This drive has been tested according to European standard IEC/EN 61800-5-1:2007, and it fully complies with the Low Voltage Directive.

To comply with the Low Voltage Directive, be sure to meet the following conditions when combining this drive with other devices:

■ Area of Use

Do not use drives in areas with pollution higher than degree 2 and overvoltage category 3 in accordance with IEC/EN 60664.

■ Factory Recommended Branch Circuit Protection

Yaskawa recommends installing one of the following types of branch circuit protection to maintain compliance with UL508C. Semiconductor protective type fuses are preferred. Alternate branch circuit protection devices are also listed in [Table i.25](#).

NOTICE: If a fuse is blown or a Ground Fault Circuit Interrupter (GFCI) is tripped, check the wiring and the selection of peripheral devices to identify the cause. Contact Yaskawa before restarting the drive or the peripheral devices if the cause cannot be identified.

Table i.25 Factory Recommended Drive Branch Circuit Protection

Drive Model	Fuse Type	
	Manufacturer: Bussmann	
	Model	Fuse Ampere Rating (A)
Three-Phase 200 V Class		
2A0004	FWH-70B	70
2A0006	FWH-70B	70
2A0008	FWH-70B	70
2A0010	FWH-70B	70
2A0012	FWH-70B	70
2A0018	FWH-90B	90
2A0021	FWH-90B	90
2A0030	FWH-100B	100
2A0040	FWH-200B	200
2A0056	FWH-200B	200
2A0069	FWH-200B	200

Drive Model	Fuse Type	
	Manufacturer: Bussmann	
	Model	Fuse Ampere Rating (A)
2A0081	FWH-300A	300
2A0110	FWH-300A	300
2A0138	FWH-350A	350
2A0169	FWH-400A	400
2A0211	FWH-400A	400
2A0250	FWH-600A	600
2A0312	FWH-700A	700
2A0360	FWH-800A	800
2A0415	FWH-1000A	1000
Three-Phase 400 V Class		
4A0002	FWH-40B	40
4A0004	FWH-50B	50
4A0005	FWH-70B	70
4A0007	FWH-70B	70
4A0009	FWH-90B	90
4A0011	FWH-90B	90
4A0018	FWH-80B	80
4A0023	FWH-100B	100
4A0031	FWH-125B	125
4A0038	FWH-200B	200
4A0044	FWH-250A	250
4A0058	FWH-250A	250
4A0072	FWH-250A	250
4A0088	FWH-250A	250
4A0103	FWH-250A	250
4A0139	FWH-350A	350
4A0165	FWH-400A	400
4A0208	FWH-500A	500
4A0250	FWH-600A	600
4A0296	FWH-700A	700
4A0362	FWH-800A	800
4A0414	FWH-800A	800
4A0515	FWH-1000A	1000
4A0675	FWH-1200A	1200
4A0930	FWH-1200A	1200
4A1200	FWH-1600A	1600
Three-Phase 600 V Class		
5A0003 </>	FWP-50B	50
5A0004 </>	FWP-50B	50
5A0006 </>	FWP-60B	60
5A0009 </>	FWP-60B	60
5A0011 </>	FWP-70B	70
5A0017 </>	FWP-100B	100
5A0022 </>	FWP-100B	100
5A0027 </>	FWP-125A	125
5A0032 </>	FWP-125A	125
5A0041 </>	FWP-175A	175

i.9 Standards Compliance

Drive Model	Fuse Type	
	Manufacturer: Bussmann	
	Model	Fuse Ampere Rating (A)
5A0052 <1>	FWP-175A	175
5A0062 <1>	FWP-250A	250
5A0077 <1>	FWP-250A	250
5A0099 <1>	FWP-250A	250
5A0125 <1>	FWP-350A	350
5A0145 <1>	FWP-350A	350
5A0192 <1>	FWP-600A	600
5A0242 <1>	FWP-600A	600

<1> 600 V class drives are not compliant with European Standards.

■ Grounding

The drive is designed to be used in T-N (grounded neutral point) networks. If installing the drive in other types of grounded systems, contact your Yaskawa representative for instructions.

■ Guarding Against Harmful Materials

When installing IP00/Open Type enclosure drives, use an enclosure that prevents foreign material from entering the drive from above or below.

◆ EMC Guidelines Compliance

This drive is tested according to European standards IEC/EN 61800-3: 2004.

■ EMC Filter Installation

The following conditions must be met to ensure continued compliance with guidelines.

Installation Method

Verify the following installation conditions to ensure that other devices and machinery used in combination with this drive also comply with EMC guidelines.

1. Install an EMC noise filter to the input side specified by Yaskawa for compliance with European standards.
2. Place the drive and EMC noise filter in the same enclosure.
3. Use braided shield cable for the drive and motor wiring, or run the wiring through a metal conduit.
4. Keep wiring as short as possible. Ground the shield on both the drive side and the motor side.

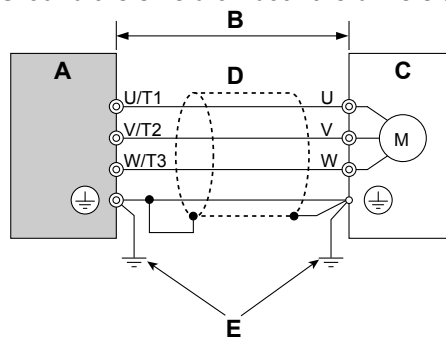

A – Drive

B – 10 m max cable length between drive and motor

C – Motor

D – Metal conduit

E – Ground wire should be as short as possible.

Figure i.34 Installation Method

5. Make sure the protective earthing conductor complies with technical standards and local safety regulations.

WARNING! *Electrical Shock Hazard. Because the leakage current exceeds 3.5 mA in models 4A0414 to 4A1200, IEC/EN 61800-5-1 states that either the power supply must be automatically disconnected in case of discontinuity of the protective earthing conductor, or a protective earthing conductor with a cross-section of at least 10 mm² (Cu) or 16 mm² (Al) must be used. Failure to comply may result in death or serious injury.*

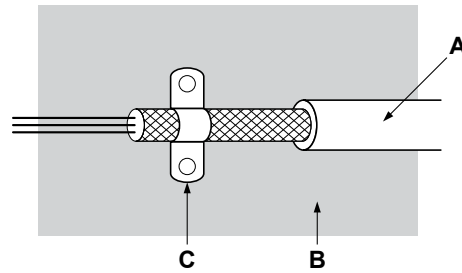

A – Braided shield cable
B – Metal panel

C – Cable clamp (conductive)

Figure i.35 Ground Area

6. Connect a DC link choke to minimize harmonic distortion.

Three-Phase 200 V / 400 V Class

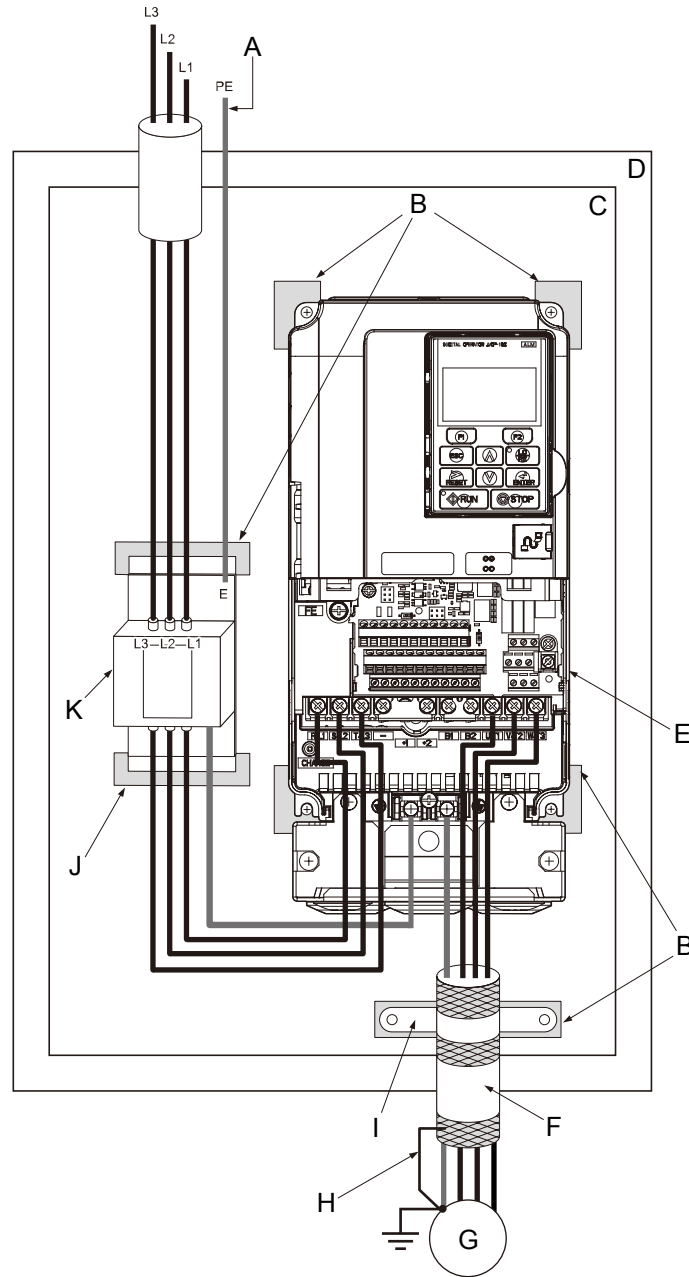

- | | |
|---|--|
| <p>A – Make sure the ground wire is grounded</p> <p>B – Grounding surface (remove any paint or sealant)</p> <p>C – Metal plate</p> <p>D – Enclosure panel</p> <p>E – Drive</p> <p>F – Motor cable (braided shield cable, max. 10 m)</p> | <p>G – Motor</p> <p>H – Cable shield ground</p> <p>I – Cable clamp</p> <p>J – Ground plate (scrape off any visible paint)</p> <p>K – EMC noise filter</p> |
|---|--|

Figure i.36 EMC Filter and Drive Installation for CE Compliance (Three-Phase 200 V / 400 V Class)

◆ UL Standards Compliance



Figure i.37 UL/cUL Mark

The UL/cUL mark applies to products in the United States and Canada. It indicates that UL has performed product testing and evaluation, and determined that their stringent standards for product safety have been met. For a product to receive UL certification, all components inside that product must also receive UL certification.

This drive is tested in accordance with UL standard UL508C and complies with UL requirements. The conditions described below must be met to maintain compliance when using this drive in combination with other equipment:

■ Installation Area

Do not install the drive to an area greater than pollution degree 2 (UL standard).

■ Main Circuit Terminal Wiring

Yaskawa recommends using closed-loop crimp terminals on all drive models. To maintain UL/cUL approval, UL Listed closed-loop crimp terminals are specifically required when wiring the drive main circuit terminals on models 2A0110 to 2A0415, 4A0058 to 4A1200, and 5A0041 to 5A0242. Use only the tools recommended by the terminal manufacturer for crimping. [Refer to Closed-Loop Crimp Terminal Size on page 103](#) for closed-loop crimp terminal recommendations.

Wire Gauges and Tightening Torques

[Refer to Main Circuit Wire Gauges and Tightening Torques on page 26.](#)

Closed-Loop Crimp Terminal Recommendations

To maintain UL/cUL approval, UL Listed closed-loop crimp terminals are specifically required when wiring the drive main circuit terminals on models 2A0110 to 2A0415, 4A0058 to 4A1200, and 5A0041 to 5A0242. Use only the tools recommended by the terminal manufacturer for crimping. Yaskawa recommends crimp terminals made by JST and Tokyo DIP (or equivalent) for the insulation cap. [Table i.26](#) matches the wire gauges and terminal screw sizes with Yaskawa-recommended crimp terminals, tools, and insulation caps. Refer to the appropriate Wire Gauge and Torque Specifications table for the wire gauge and screw size for your drive model. Place orders with a Yaskawa representative or the Yaskawa sales department.

Wire gauge values shown in ***bold italic*** are the recommended values. Refer to local codes for proper selections.

Table i.26 Closed-Loop Crimp Terminal Size

Drive Model	Wire Gauge (AWG, kcmil)		Screw Size	Crimp Terminal Model Number	Tool		Insulation Cap Model No.	Code ^{<1>}	
	R/L1, S/L2, T/L3	U/T1, V/T2, W/T3			Machine No.	Die Jaw			
200 V Class									
2A0004 2A0006 2A0008 2A0010	<i>14</i>		M4	R2-4	YA-4	AD-900	TP-003	100-054-028	
	12			R5.5-4			TP-005	100-054-029	
	10								
2A0012	14	<i>14</i>	M4	R2-4	YA-4	AD-900	TP-003	100-054-028	
	<i>12</i>	12		R5.5-4			TP-005	100-054-029	
	10								
2A0018	–	14	M4	R2-4	YA-4	AD-900	TP-003	100-054-028	
	12			R5.5-4			TP-005	100-054-029	
	<i>10</i>								
2A0021	12		M4	R5.5-4	YA-4	AD-900	TP-005	100-054-029	
	<i>10</i>								
2A0030	10		M4	R5.5-4	YA-4	AD-900	TP-005	100-054-029	
	<i>8</i>			8-4			AD-901	TP-008	100-054-031
	6			14-NK4			AD-902	TP-014	100-054-033

i.9 Standards Compliance

Drive Model	Wire Gauge (AWG, kcmil)		Screw Size	Crimp Terminal Model Number	Tool		Insulation Cap Model No.	Code <?>
	R/L1, S/L2, T/L3	U/T1, V/T2, W/T3			Machine No.	Die Jaw		
2A0040	8	8	M4	8-4	YA-4	AD-901	TP-008	100-054-031
	6	6		14-NK4		AD-902	TP-014	100-054-033
2A0056	6		M6	R14-6	YA-5	AD-952	TP-014	100-051-261
	4			R22-6		AD-953	TP-022	100-051-262
2A0069	4		M8	R22-8	YA-5	AD-953	TP-022	100-051-263
	3			R38-8		AD-954	TP-038	100-051-264
2A0081	3		M8	R38-8	YA-5	AD-954	TP-038	100-051-264
	2							
2A0110	3		M8	R38-8	YA-5	AD-954	TP-038	100-051-264
	2							
	1							
	1/0							
2A0138	1		M10	R38-10	YF-1 YET-300-1	TD-321, TD-311	TP-060	100-061-114
	1/0			R60-10		TD-323, TD-312		100-051-266
	2/0			70-10		TP-080	100-054-036	
2A0169	2/0	–	M10	70-10	YF-1 YET-300-1	TD-323, TD-312	TP-080	100-054-036
	3/0			80-10		TD-324, TD-312		100-051-267
	4/0			R100-10		TP-100	100-051-269	
2A0211	1/0 × 2P		M10	R60-10	YF-1 YET-300-1	TD-321, TD-311	TP-060	100-051-266
	2/0 × 2P			70-10		TD-323, TD-312		
2A0250	3/0 × 2P		M12	80-L12	YF-1 YET-300-1	TD-323, TD-312	TP-080	100-051-558
	4/0 × 2P			100-L12		TD-324, TD-312		
	–	250 × 2P		150-L12		TD-325, TD-313	TP-150	100-051-562
	250	–		R150-12			TP-150	100-051-273
	300							
2A0312	3/0 × 2P	3/0 × 2P	M12	80-L12	YF-1 YET-300-1	TD-323, TD-312	TP-080	100-051-558
	4/0 × 2P	4/0 × 2P		100-L12		TD-324, TD-312		
	250 × 2P			150-L12		TD-325, TD-313	TP-150	100-051-562
	300 × 2P							
2A0360	4/0 × 2P	4/0 × 2P	M12	100-L12	YF-1 YET-300-1	TD-324, TD-312	TP-100	100-051-560
	250 × 2P	250 × 2P		150-L12		TD-325, TD-313		
	300 × 2P			180-L12		TD-327, TD-314	TP-200	100-066-688
	350 × 2P			200-L12				100-051-564
	400 × 2P			325-12			TD-328, TD-315	TP-325
	500 × 2P							
	600	600 × 2P						
2A0415	250 × 2P	–	M12	150-L12	YF-1 YET-300-1	TD-325, TD-313	TP-150	100-051-562
	300 × 2P	300 × 2P		180-L12		TD-327, TD-314		
	350 × 2P	350 × 2P		200-L12			100-051-564	
	400 × 2P			325-12			TD-328, TD-315	TP-325
	500 × 2P							
	600 × 2P							

Drive Model	Wire Gauge (AWG, kcmil)		Screw Size	Crimp Terminal Model Number	Tool		Insulation Cap Model No.	Code <1>	
	R/L1, S/L2, T/L3	U/T1, V/T2, W/T3			Machine No.	Die Jaw			
400 V Class									
4A0002 4A0004 4A0005 4A0007 4A0009	14		M4	R2-4	YA-4	AD-900	TP-003	100-054-028	
	12			R5.5-4			TP-005	100-054-029	
	10								
4A0011	14	14	M4	R2-4	YA-4	AD-900	TP-003	100-054-028	
	12	12		R5.5-4			TP-005	100-054-029	
	10								
4A0018	12		M4	R5.5-4	YA-4	AD-900	TP-005	100-054-029	
	10			8-4			AD-901	TP-008	100-054-031
	8			14-NK4			AD-902	TP-014	100-054-033
	6								
4A0023	10		M4	R5.5-4	YA-4	AD-900	TP-005	100-054-029	
	8			8-4			AD-901	TP-008	100-054-031
	6			14-NK4			AD-902	TP-014	100-054-033
4A0031	-	10	M5	R5.5-5	YA-4	AD-900	TP-005	100-054-030	
	8			R8-5			AD-901	TP-008	100-054-032
	6			R14-5			AD-902	TP-014	100-054-034
4A0038	8	8	M5	R8-5	YA-4	AD-901	TP-008	100-054-032	
	6	6		R14-5			AD-902	TP-014	100-054-034
4A0044	6		M6	R14-6	YA-5	AD-952	TP-014	100-051-261	
	4			R22-6			AD-953	TP-022	100-051-262
4A0058	6		M8	R14-8	YA-5	AD-952	TP-014	100-054-035	
	4			R22-8			AD-953	TP-022	100-051-263
4A0072	4		M8	R22-8	YA-5	AD-953	TP-022	100-051-263	
	3			R38-8			AD-954	TP-038	100-051-264
4A0088	3		M8	R38-8	YA-5	AD-954	TP-038	100-051-264	
	2								
	1								
	1/0								R60-8
4A0103	2		M8	R38-8	YA-5	AD-954	TP-038	100-051-264	
	1	1							
	1/0	1/0							R60-8
4A0139	1/0		M10	R60-10	YF-1 YET-300-1	TD-321, TD-311	TP-060	100-051-266	
	2/0	2/0		70-10		TD-323, TD-312	TP-080	100-054-036	
	3/0	3/0		80-10				100-051-267	
	4/0			R100-10		TD-324, TD-312	TP-100	100-051-269	
4A0165	3/0		M10	80-10	YF-1 YET-300-1	TD-323, TD-312	TP-080	100-051-267	
	4/0			R100-10		TD-324, TD-312	TP-100	100-051-269	
4A0208	2 × 2P		M10	38-L10	YF-1 YET-150-1	TD-224, TD-212	TP-038	100-051-556	
	1 × 2P			80-L10		TD-227, TD-214	TP-080	100-051-557	
	3/0 × 2P			R100-10		TD-228, TD-214	TP-100	100-051-269	
	4/0			R150-10		TD-229, TD-215	TP-150	100-051-272	
	250								
	300								

i.9 Standards Compliance

Drive Model	Wire Gauge (AWG, kcmil)		Screw Size	Crimp Terminal Model Number	Tool		Insulation Cap Model No.	Code <?>
	R/L1, S/L2, T/L3	U/T1, V/T2, W/T3			Machine No.	Die Jaw		
4A0250	1 × 2P	–	M10	38-L10	YF-1 YET-150-1	TD-224, TD-212	TP-038	100-051-556
	3/0 × 2P			80-L10		TD-227, TD-214	TP-080	100-051-557
	4/0 × 2P			100-L10		TD-228, TD-214	TP-100	100-051-559
	250 × 2P			150-L10		TD-229, TD-215	TP-150	100-051-561
	300			R150-10		TP-150	100-051-272	
	350			180-10	YF-1 YET-300-1	TD-327, TD-314	TP-200	100-066-687
	400			200-10		100-051-563		
	500			325-10		TD-328, TD-315	TP-325	100-051-565
	600							
4A0296	3/0 × 2P		M12	80-L12	YF-1 YET-300-1	TD-323, TD-312	TP-080	100-051-558
	4/0 × 2P			100-L12		TD-324, TD-312	TP-100	100-051-560
	250 × 2P			150-L12		TD-325, TD-313	TP-150	100-051-562
	300 × 2P			180-L12		TD-327, TD-314	TP-200	100-066-688
	–	350 × 2P		180-12				100-066-689
	350	–		R200-12				100-051-275
	400			325-12		TD-328, TD-315	TP-325	100-051-277
	500							
	600							
4A0362	3/0 × 2P		M12	80-L12	YF-1 YET-300-1	TD-323, TD-312	TP-080	100-051-558
	4/0 × 2P			100-L12		TD-324, TD-312	TP-100	100-051-560
	250 × 2P			150-L12		TD-325, TD-313	TP-150	100-051-562
	300 × 2P			180-L12		TD-327, TD-314	TP-200	100-066-688
	350 × 2P			200-L12				100-051-564
	400 × 2P			325-12		TD-328, TD-315	TP-325	100-051-277
	500							
	600							
4A0414	4/0 × 2P		M12	100-L12	YF-1 YET-300-1	TD-324, TD-312	TP-100	100-051-560
	250 × 2P			150-L12		TD-325, TD-313	TP-150	100-051-562
	300 × 2P							
4A0515	3/0 × 4P	3/0 × 4P	M12	80-L12	YF-1 YET-300-1	TD-323, TD-312	TP-080	100-051-558
	4/0 × 4P	4/0 × 4P		100-L12		TD-324, TD-312	TP-100	100-051-560
	250 × 4P			150-L12		TD-325, TD-313	TP-150	100-051-562
	300 × 2P							
4A0675	4/0 × 4P		M12	100-L12	YF-1 YET-300-1	TD-324, TD-312	TP-100	100-051-560
	250 × 4P			150-L12		TD-325, TD-313	TP-150	100-051-562
	300 × 4P							
4A0930	3/0 × 8P		M12	80-L12	YF-1 YET-300-1	TD-323, TD-312	TP-080	100-051-558
	4/0 × 8P			100-L12		TD-324, TD-312	TP-100	100-051-560
	250 × 8P			150-L12		TD-325, TD-313	TP-150	100-051-562
	300 × 8P							

Drive Model	Wire Gauge (AWG, kcmil)		Screw Size	Crimp Terminal Model Number	Tool		Insulation Cap Model No.	Code <1>
	R/L1, S/L2, T/L3	U/T1, V/T2, W/T3			Machine No.	Die Jaw		
4A1200	4/0 × 8P		M12	100-L12	YF-1 YET-300-1	TD-324, TD-312	TP-100	100-051-560
	250 × 8P			150-L12		TD-325, TD-313	TP-150	100-051-562
	300 × 8P							

<1> Codes refer to a set of three crimp terminals and three insulation caps. Prepare input and output wiring using two sets for each connection. Example 1: Models with 300 kcmil for both input and output require one set for input terminals and one set for output terminals, so the user should order two sets of [100-051-272]. Example 2: Models with 4/0 AWG × 2P for both input and output require two sets for input terminals and two sets for output terminals, so the user should order four sets of [100-051-560].

Note: Use crimp insulated terminals or insulated shrink tubing for wiring connections. Wires should have a continuous maximum allowable temperature of 75 °C 600 Vac UL-approved vinyl-sheathed insulation.

Factory Recommended Branch Circuit Protection for UL Compliance

NOTICE: If a fuse is blown or a Ground Fault Circuit Interrupter (GFCI) is tripped, check the wiring and the selection of the peripheral devices. Check the wiring and the selection of peripheral devices to identify the cause. Contact Yaskawa before restarting the drive or the peripheral devices if the cause cannot be identified.

Yaskawa recommends installing one of the following types of branch circuit protection to maintain compliance with UL508C. Semiconductor protective type fuses are preferred. Alternate branch circuit protection devices are also listed in the tables below.

Table i.27 Factory Recommended Drive Branch Circuit Protection (Normal Duty)

Drive Model	Normal Duty					
	Nominal Output Power HP	AC Drive Input Amps	MCCB Rating Amps <1>	Time Delay Fuse Rating Amps <2>	Non-time Delay Fuse Rating Amps <3>	Bussmann Semiconductor Fuse Rating (Fuse Ampere) <4>
200 V Class						
2A0004	0.75	3.9	15	6.25	10	FWH-70B (70)
2A0006	1 - 1.5	7.3	15	12	20	FWH-70B (70)
2A0008	2	8.8	15	15	25	FWH-70B (70)
2A0010	3	10.8	20	17.5	30	FWH-70B (70)
2A0012	3	13.9	25	20	40	FWH-70B (70)
2A0018	5	18.5	35	30	50	FWH-90B (90)
2A0021	7.5	24	45	40	70	FWH-90B (90)
2A0030	10	37	60	60	110	FWH-100B (100)
2A0040	15	52	100	90	150	FWH-200B (200)
2A0056	20	68	125	110	200	FWH-200B (200)
2A0069	25	80	150	125	225	FWH-200B (200)
2A0081	30	96	175	150	275	FWH-300A (300)
2A0110	40	111	200	175	300	FWH-300A (300)
2A0138	50	136	250	225	400	FWH-350A (350)
2A0169	60	164	300	250	450	FWH-400A (400)
2A0211	75	200	400	350	600	FWH-400A (400)
2A0250	100	271	500	450	800	FWH-600A (600)
2A0312	125	324	600	500	800	FWH-700A (700)
2A0360	150	394	700	600	1000 <5>	FWH-800A (800)
2A0415	175	471	900	800	1400 <5>	FWH-1000A (1000)
400 V Class						
4A0002	1	2.1	15	3.5	6	FWH-40B (40)
4A0004	2	4.3	15	7.5	12	FWH-50B (50)
4A0005	3	5.9	15	10	17.5	FWH-70B (70)

i.9 Standards Compliance

Drive Model	Normal Duty					
	Nominal Output Power HP	AC Drive Input Amps	MCCB Rating Amps <1>	Time Delay Fuse Rating Amps <2>	Non-time Delay Fuse Rating Amps <3>	Busmann Semiconductor Fuse Rating (Fuse Ampere) <4>
4A0007	3	8.1	15	12	20	FWH-70B (70)
4A0009	5	9.4	15	15	25	FWH-90B (90)
4A0011	7.5	14	25	20	40	FWH-90B (90)
4A0018	10	20	40	35	60	FWH-80B (80)
4A0023	15	24	45	40	70	FWH-100B (100)
4A0031	20	38	75	60	110	FWH-125B (125)
4A0038	25	44	75	75	125	FWH-200B (200)
4A0044	30	52	100	90	150	FWH-250A (250)
4A0058	40	58	100	100	150	FWH-250A (250)
4A0072	50	71	125	110	200	FWH-250A (250)
4A0088	60	86	150	150	250	FWH-250A (250)
4A0103	75	105	200	175	300	FWH-250A (250)
4A0139	100	142	250	225	400	FWH-350A (350)
4A0165	125	170	300	250	500	FWH-400A (400)
4A0208	150	207	400	350	600	FWH-500A (500)
4A0250	200	248	450	400	700	FWH-600A (600)
4A0296	250	300	600	500	800	FWH-700A (700)
4A0362	300	346	600	600	1000 <5>	FWH-800A (800)
4A0414	350	410	800	700	1200 <5>	FWH-800A (800)
4A0515	400 - 450	465	900	800	1350 <5>	FWH-1000A (1000)
4A0675	500 - 600	657	1200	1100 <5>	1800 <5>	FWH-1200A (1200)
4A0930	700 - 800	922	Not Applicable			FWH-1200A (1200)
4A1200	900 - 1000	1158	Not Applicable			FWH-1600A (1600)
600 V Class						
5A0003	2	3.6	15	6.25	10	FWP-50B (50)
5A0004	3	5.1	15	8	15	FWP-50B (50)
5A0006	5	8.3	15	12	20	FWP-60B (60)
5A0009	7.5	12	20	20	35	FWP-60B (60)
5A0011	10	16	30	25	45	FWP-70B (70)
5A0017	15	23	40	40	60	FWP-100B (100)
5A0022	20	31	60	50	90	FWP-100B (100)
5A0027	25	38	75	60	110	FWP-125A (125)
5A0032	30	45	75	75	125	FWP-125A (125)
5A0041	40	44	75	75	125	FWP-175A (175)
5A0052	50	54	100	90	150	FWP-175A (175)
5A0062	60	66	125	110	175	FWP-250A (250)
5A0077	75	80	150	125	225	FWP-250A (250)
5A0099	100	108	175	175	300	FWP-250A (250)
5A0125	125	129	225	225	350	FWP-350A (350)
5A0145	150	158	300	275	450	FWP-350A (350)
5A0192	200	228	400	350	600	FWP-600A (600)
5A0242	250	263	500	450	700	FWP-600A (600)

<1> Maximum MCCB Rating is 15 A, or 200 % of drive input current rating, whichever is larger. MCCB voltage rating must be 600 VAC or greater.

<2> Maximum Time Delay fuse is 175% of drive input current rating. This covers any Class CC, J or T class fuse.

<3> Maximum Non-time Delay fuse is 300% of drive input current rating. This covers any CC, J or T class fuse.

<4> When using semiconductor fuses, Bussman FWH and FWP are required for UL compliance. Select FWH for 200 V Class and 400 V Class models and FWP fuses for 600 V models.

<5> Class L fuse is also approved for this rating.

Wiring Fuses for Models 4A0930 and 4A1200

NOTICE: If a fuse is blown or an Ground Fault Circuit Interrupter (GFCI) is tripped, check the wiring and the selection of peripheral devices to identify the cause. Contact Yaskawa before restarting the drive or the peripheral devices if the cause cannot be identified.

Install a fuse on the input side to protect drive wiring and prevent other secondary damage. Wire the fuse so that leakage current in the upper controller power supply will trigger the fuse and shut off the power supply.

Select the appropriate fuse from [Table i.3](#).

Table i.28 Input Fuses for Models 4A0930 and 4A1200

Voltage Class	Model	Selection			Input Fuse (Example)			
		Input Voltage	Current	Pre-arc I^2t (A ² s)	Model	Manufacturer	Rating	Pre-arc I^2t (A ² s)
Three-Phase 400 V Class	4A0930	480 V	1500 A	140000 to 3100000	CS5F-1200	Fuji Electric	AC500 V, 1200 A	276000
	FWH-1200A				Bussman	AC500 V, 1200 A	–	
	FWH-1000A				Bussman	AC500 V, 1000 A	–	
	4A1200	480 V	1500 A	320000 to 3100000	CS5F-1500	Fuji Electric	AC500 V, 1500 A	351000
	FWH-1600A				Bussman	AC500 V, 1600 A	–	
	FWH-1200A				Bussman	AC500 V, 1200 A	–	

Low Voltage Wiring for Control Circuit Terminals

Wire low voltage wires with NEC Class 1 circuit conductors. Refer to national state or local codes for wiring. The external power supply shall be a UL listed Class 2 power supply source or equivalent only.

Table i.29 Control Circuit Terminal Power Supply

Input / Output	Terminal Signal	Power Supply Specifications
Digital inputs	S1 to S8, SC	Use the internal LVLC power supply of the drive. Use class 2 for external power supply.
Analog inputs / outputs	+V, A1, A2, A3, AC, AM, FM	Use the internal LVLC power supply of the drive. Use class 2 for external power supply.

Drive Short Circuit Rating

The drive is suitable for use on a circuit capable of delivering not more than 100,000 RMS symmetrical Amperes, 240 Vac maximum (200 V Class), 480 Vac maximum (400 V Class), and 600 Vac maximum (600 V Class) when protected by Bussmann Type FWH or FWP fuses as specified in [Factory Recommended Branch Circuit Protection](#) on page 98.

CSA Standards Compliance



Figure i.38 CSA Mark

CSA for Industrial Control Equipment

The drive is CSA-certified as Industrial Control Equipment Class 3211.

Specifically, the drive is certified to: CAN/CSA C22.2 No. 04-04 and CAN/CSA C22.2 No.14-05.

Drive Motor Overload Protection

Set parameter E2-01 (motor rated current) to the appropriate value to enable motor overload protection. The internal motor overload protection is UL Listed and in accordance with the NEC and CEC.

i.9 Standards Compliance

■ E2-01: Motor Rated Current

Setting Range: Model-dependent

Default Setting: Model-dependent

Parameter E2-01 protects the motor when parameter L1-01 is not set to 0. The default for L1-01 is 1, which enables protection for standard induction motors.

If Auto-Tuning has been performed successfully, the motor data entered to T1-04 is automatically written to parameter E2-01. If Auto-Tuning has not been performed, manually enter the correct motor rated current to parameter E2-01.

■ L1-01: Motor Overload Protection Selection

The drive has an electronic overload protection function (oL1) based on time, output current, and output frequency that protects the motor from overheating. The electronic thermal overload function is UL-recognized, so it does not require an external thermal relay for single motor operation.

This parameter selects the motor overload curve used according to the type of motor applied.

Table i.30 Overload Protection Settings

Setting	Description	
0	Disabled	Disabled the internal motor overload protection of the drive.
1	Standard fan-cooled motor (60 Hz default)	Selects protection characteristics for a standard self-cooled motor with limited cooling capabilities when running below the rated speed. The motor overload detection level (oL1) is automatically reduced when running below the motor rated speed.
2	Drive duty motor with a speed range of 1:10	Selects protection characteristics for a motor with self-cooling capability within a speed range of 10:1. The motor overload detection level (oL1) is automatically reduced when running below 1/10 of the motor rated speed.
3	Vector motor with a speed range of 1:100	Selects protection characteristics for a motor capable of cooling itself at any speed including zero speed (externally cooled motor). The motor overload detection level (oL1) is constant over the entire speed range.
6	Standard fan-cooled motor (50 Hz)	Selects protection characteristics for a standard self-cooled motor with limited cooling capabilities when running below the rated speed. The motor overload detection level (oL1) is automatically reduced when running below the motor rated speed.

When connecting the drive to more than one motor for simultaneous operation, disable the electronic overload protection (L1-01 = 0) and wire each motor with its own motor thermal overload relay.

Enable motor overload protection (L1-01 ≠ 0) when connecting the drive to a single motor, unless another motor overload preventing device is installed. The drive electronic thermal overload function causes an oL1 fault, which shuts off the output of the drive and prevents additional overheating of the motor. The motor temperature is continually calculated while the drive is powered up.

■ L1-02: Motor Overload Protection Time

Setting Range: 0.1 to 5.0 min

Factory Default: 1.0 min

Parameter L1-02 determines how long the motor is allowed to operate before the oL1 fault occurs when the drive is running a hot motor at 60 Hz and at 150% of the full load amp rating (E2-01) of the motor. Adjusting the value of L1-02 can shift the set of oL1 curves up the y axis of the diagram below, but will not change the shape of the curves.

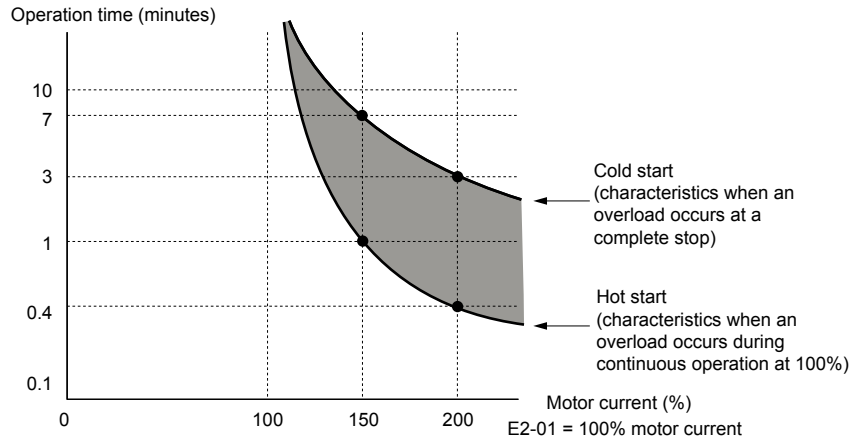

Figure i.39 Motor Overload Protection Time

Revision History

The revision dates and the numbers of the revised manuals appear on the bottom of the back cover.

MANUAL NO. TOEP YAIP1W 02B <1>
 Published in USA January 2014
 Revision number
 Date of publication

Date of Publication	Revision Number	Section(s)	Revised Content
September 2022	<6>	All	Revision: Updated documentation to support drive software versions PRG: 8555 and 8556.
March 2017	<5>	All	Revision: Reviewed and corrected documentation.
August 2016	<4>	All	Updated documentation to support drive software version PRG: 8554.
April 2016	<3>	All	Updated documentation to support drive software version PRG: 8553.
October 2015	<2>	All	Revision: Document title Revision: Reviewed and corrected entire documentation. Updated documentation to support drive software version PRG: 8552.
January 2014	<1>	All	Addition: Support for models 4A0930 and 4A1200. Sections for Keypad Operation, Start-up, Parameter Table, and Troubleshooting. Revision: Removed Parameter Setting Reference Table.
July 2013	-	-	First Edition

This Page Intentionally Blank

iQpump1000 AC Drive

Intelligent Pump Controller

Installation & Start-Up Guide

YASKAWA AMERICA, INC.

2121, Norman Drive South, Waukegan, IL 60085, U.S.A.
Phone: 1-800-YASKAWA (927-5292) or 1-847-887-7000 Fax: 1-847-887-7310
<http://www.yaskawa.com>

DRIVE CENTER (INVERTER PLANT)

2-13-1, Nishimiyaichi, Yukuhashi, Fukuoka, 824-8511, Japan
Phone: 81-930-25-3844 Fax: 81-930-25-4369
<http://www.yaskawa.co.jp>

YASKAWA ELECTRIC CORPORATION

New Pier Takeshiba South Tower, 1-16-1, Kaigan, Minatoku, Tokyo, 105-6891, Japan
Phone: 81-3-5402-4502 Fax: 81-3-5402-4580
<http://www.yaskawa.co.jp>

YASKAWA ELÉTRICO DO BRASIL LTDA.

777, Avenida Piraporinha, Diadema, São Paulo, 09950-000, Brasil
Phone: 55-11-3585-1100 Fax: 55-11-3585-1187
<http://www.yaskawa.com.br>

YASKAWA EUROPE GmbH

185, Hauptstraße, Eschborn, 65760, Germany
Phone: 49-6196-569-300 Fax: 49-6196-569-398
<http://www.yaskawa.eu.com>

YASKAWA ELECTRIC KOREA CORPORATION

9F, Kyobo Securities Bldg., 26-4, Yeouido-dong, Yeongdeungpo-gu, Seoul, 150-737, Korea
Phone: 82-2-784-7844 Fax: 82-2-784-8495
<http://www.yaskawa.co.kr>

YASKAWA ELECTRIC (SINGAPORE) PTE. LTD.

151, Lorong Chuan, #04-02A, New Tech Park, 556741, Singapore
Phone: 65-6282-3003 Fax: 65-6289-3003
<http://www.yaskawa.com.sg>

YASKAWA ELECTRIC (THAILAND) CO., LTD.

252/125-126, 27th Floor, Muang Thai-Phatra Tower B, Rachadapisek Road, Huaykwang, Bangkok, 10310, Thailand
Phone: 66-2693-2200 Fax: 66-2693-4200
<http://www.yaskawa.co.th>

YASKAWA ELECTRIC (CHINA) CO., LTD.

22F, One Corporate Avenue, No.222, Hubin Road, Shanghai, 200021, China
Phone: 86-21-5385-2200 Fax: 86-21-5385-3299
<http://www.yaskawa.com.cn>

YASKAWA ELECTRIC (CHINA) CO., LTD. BEIJING OFFICE

Room 1011, Tower W3 Oriental Plaza, No. 1, East Chang An Ave.,
Dong Cheng District, Beijing, 100738, China
Phone: 86-10-8518-4086 Fax: 86-10-8518-4082

YASKAWA ELECTRIC TAIWAN CORPORATION

9F, 16, Nanking E. Rd., Sec. 3, Taipei, 104, Taiwan
Phone: 886-2-2502-5003 Fax: 886-2-2505-1280

YASKAWA INDIA PRIVATE LIMITED

#17/A, Electronics City, Hosur Road, Bangalore, 560 100 (Karnataka), India
Phone: 91-80-4244-1900 Fax: 91-80-4244-1901
<http://www.yaskawaindia.in>

YASKAWA**YASKAWA AMERICA, INC.**

TOEPYAIP1W02

In the event that the end user of this product is to be the military and said product is to be employed in any weapons systems or the manufacture thereof, the export will fall under the relevant regulations as stipulated in the Foreign Exchange and Foreign Trade Regulations. Therefore, be sure to follow all procedures and submit all relevant documentation according to any and all rules, regulations and laws that may apply.

Specifications are subject to change without notice for ongoing product modifications and improvements.

© 2013 YASKAWA AMERICA, INC.

MANUAL NO. TOEPYAIP1W02F<6>

Published in USA October 2022