

# DANCER POSITION WINDER OPTION ASSEMBLY

**46S02371-0160    SCHEMATIC 45S02371-0160**  
**46S02371-1160    SCHEMATIC 45S02371-1160**

DESCRIPTION

This option is one of a series available for Louis Allis Saber DC drives. It consists of components necessary for modifying the basic controller to enable the drive to maintain position of a dancer on a moving process web or line.

The option compares an external DANCER potentiometer with the internal DANCER POSITION potentiometer setting and generates a current reference signal proportional to the difference in settings. The current reference signal varies the torque produced at the output shaft of the rotating equipment to maintain a constant dancer position.

In theory, the dancer position signal is the reference or desired normal maintained riding location of the dancer, whereas, the dancer signal is the

feedback or actual location. The closed control loop system of the regulator, motor and web keeps the actual dancer location close to the desired location. This modification circuit is normally used on center winders where the motor shaft speed (RPM) varies in inverse proportion to the diameter and is not basically constant like the web or line speed (FPM). In non-winding or surface winding applications, the Position Regulated Speed Follower (Dancer Trim) option is preferred for stability reasons.

An external TENSION ON relay logic switch allows switching the current reference signal between the output of the dancer position regulator and an external speed regulator. Turning on the TENSION ON relay logic switch enables the dancer position regulator. On the -1160 assembly, there is addi-

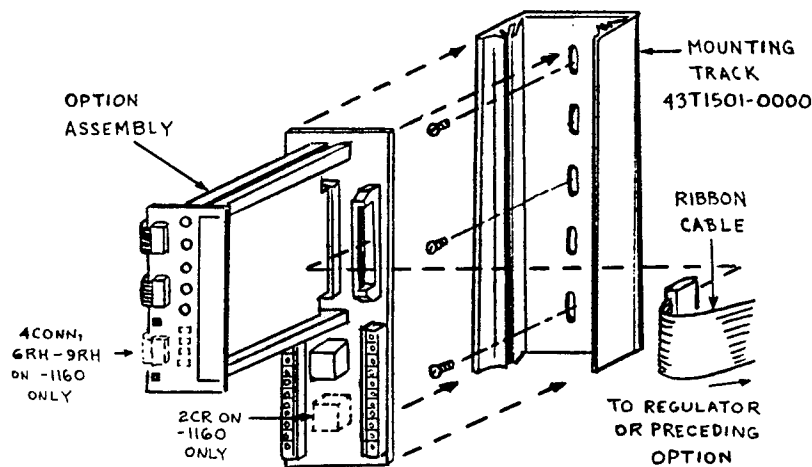

Figure 1.

CHANGE RECORD			DWG. NO. 02Y00025-0071 SHEET 1 OF 6 EFF. 8/26/86 (L)
1	STD-1717	3/1/83	
2	STD-2666	2-3-87 Res	
3	STD-2718	3-17-87 Res	

tional circuitry to allow matching the speed of the winder to the speed of the web or line and to different core size. Turning on the external SPEED MATCH ON relay logic switch enables the speed regulator. Turning on the external LARGE CORE SIZE relay logic switch adjusts the winder speed for a different core size.

The POSITION potentiometer sets the neutral point about which the DANCER potentiometer operates. The PROPORTIONAL GAIN potentiometer (2RH) sets the amount of dancer droop required to provide rated torque. The TRANSFER POSITION potentiometer (4RH) is used (when the integral channel is enabled) to limit the integral channel gain in dual turret applications, in order to assure good tension on the first few wraps on a new core, immediately after a flying splice transfer. The DANCER INTEGRATOR ENABLE switch (2SS on the Function PCB) disables the integral channel during setup, and if not required by the application. The integral channel integrates dancer error to prevent the dancer from moving its maintained (regulated) position as the rewound roll builds up. The ANTI-HUNT potentiometer (5RH) adjusts compensation for system inertia to stabilize the drive. The MAX ANTI-HUNT potentiometer (10RH) sets the range of the ANTI-HUNT potentiometer. The FRICTION BIAS potentiometer (3RH) provides a torque reference for empty rolls. On the -1160 assembly, the SMALL CORE MIN SPEED (6RH), SMALL CORE MAX SPEED (7RH), LARGE CORE MIN SPEED (8RH) and LARGE CORE MAX SPEED (9RH) potentiometers set the minimum and maximum speed settings for SMALL and LARGE core size respectively.

#### INSTALLATION

##### WARNING

REMOVE ALL INPUT POWER TO THE DRIVE BEFORE INSTALLING OPTION COMPONENTS.

See Figure 1. Install the option in the following manner:

1. Install PVC mounting track (L.A. part no. 43T1501-0000) to panel where option is to be mounted, using appropriate hardware.

2. Install option assembly by pressing firmly into mounting track.

3. Using 40 conductor ribbon, fabricate and install a double-ended ribbon cable of sufficient length to fit from 12CONN on the right side of the option to 12CONN on the Main PCB in the regulator power cube, or to 12CONN on the left side of a previously installed option.

Cable 12CONN provides the power and signal interface between this option and the Controller 40 pin data bus.

#### INTERCONNECTION

##### CAUTION

INSURE THAT ELECTRICAL PARTS OF THE DANCER POTENTIOMETER AND POSITION POTENTIOMETER WHEN EXTERNALLY MOUNTED ARE ELECTRICALLY ISOLATED FROM THE CASE AND EARTH GROUND TO PREVENT DAMAGE TO THE EQUIPMENT.

DO NOT INSTALL A POTENTIOMETER HAVING MECHANICAL ROTATIONAL STOPS AS THE DANCER POTENTIOMETER.

This modification requires that a DANCER potentiometer be installed to the machinery for process control. The ohmic value of the DANCER potentiometer should be 1K to 10K ohms. Louis Allis part number 05P00040-0192 (1K) is recommended.

An external POSITION potentiometer may be remotely installed to operate in place of 2RH on the Dancer Position Winder assembly. This external potentiometer should be 10K ohms. Louis Allis part no. 43T00572-1033 is recommended. When installing this external pot, 1SS on the Function PCB MUST BE

DWG. NO. 02Y00025-0071  
SHEET 2 OF 6  
EFF. 8/26/86 (L)

OPENED by removing the self-tapping screw. The external POSITION potentiometer is then wired according to Figure 2.

On the -1160 assembly, if an external LINE SPEED REF. signal is to be used instead of the VOLT/CURRENT FOLLOWER OUTPUT signal supplied by the drive, 3SS on the Function PCB MUST BE OPENED by removing the self-tapping screw.

Perform equipment interconnections according to the Controller instruction manual. Then wire switches and DANCER potentiometer according to Figure 2.

ADJUSTMENTS

After performing the adjustments in the Controller instruction manual, adjust the option assembly as follows:

A. Speed Match Mode Adjustments (Only on -1160 assembly).

1. Preset the pots as follows:

- 6RH SMALL CORE MIN SPEED ... 50%
- 7RH SMALL CORE MAX SPEED ... 50%
- 8RH LARGE CORE MIN SPEED ... 50%
- 9RH LARGE CORE MAX SPEED ... 50%

2. Turn off the LARGE CORE SIZE ON relay logic switch and place a small size core on the spindle.

3. Turn off the TENSION ON relay logic switch; turn on the SPEED ON relay logic switch; start the line and run at minimum (10%) speed. Adjust SMALL CORE MIN. SPEED (6RH) until the surface speed of core matches (or is 1% higher than) that of the main drive.

4. Run drive at rated line speed. Adjust SMALL CORE MAX SPEED (7RH) until the surface speed of core matches (or is 1% higher than) that of the main drive.

5. Due to control interaction, repeat steps 3 and 4 several times until the surface speed tracks (1% higher) from minimum to maximum line speed.

6. With LARGE CORE SIZE ON relay logic switch closed and a large size core on the spindle, repeat steps 3 to 5 until LARGE CORE MAX SPEED (9RH) and LARGE CORE MIN SPEED (8RH) are properly adjusted.

B. Dancer Position Regulator Adjustments (Both -0160 and -1160 assemblies).

1. Preset the pots and 2SS as follows:

- 1RH (or ext) POSITION ..... 50%
- 2RH PROPORTIONAL GAIN% ... 50%
- 5RH ANTI-HUNT ..... 50%
- 10RH MAX ANTI-HUNT ..... 50%
- 3RH FRICTION BIAS ..... 0%
- 4RH TRANSFER POSITION ... 100%
- 2SS (DANCER INTEGRATOR ENABLE) ... OPEN (OFF)

2. Close the TENSION ON relay logic switch. With no web on a rewind core, start the drive and short 2TP to common. Increase the setting on FRICTION BIAS (3RH) until the winder just starts to move, then back off slightly. Remove the common-to-2TP connection.

3. With the web in the dancer loop, run the line slowly and adjust POSITION potentiometer (1RH or external) so that the dancer maintains a position near its center of travel.

4. Adjust the PROPORTIONAL GAIN potentiometer (2RH) to make the drive as sensitive to DANCER potentiometer movement as desired. If the drive becomes unstable at higher settings,

DWG. NO. 02Y00025-0071  
SHEET 3 OF 6  
EFF. 8/26/86 (L)

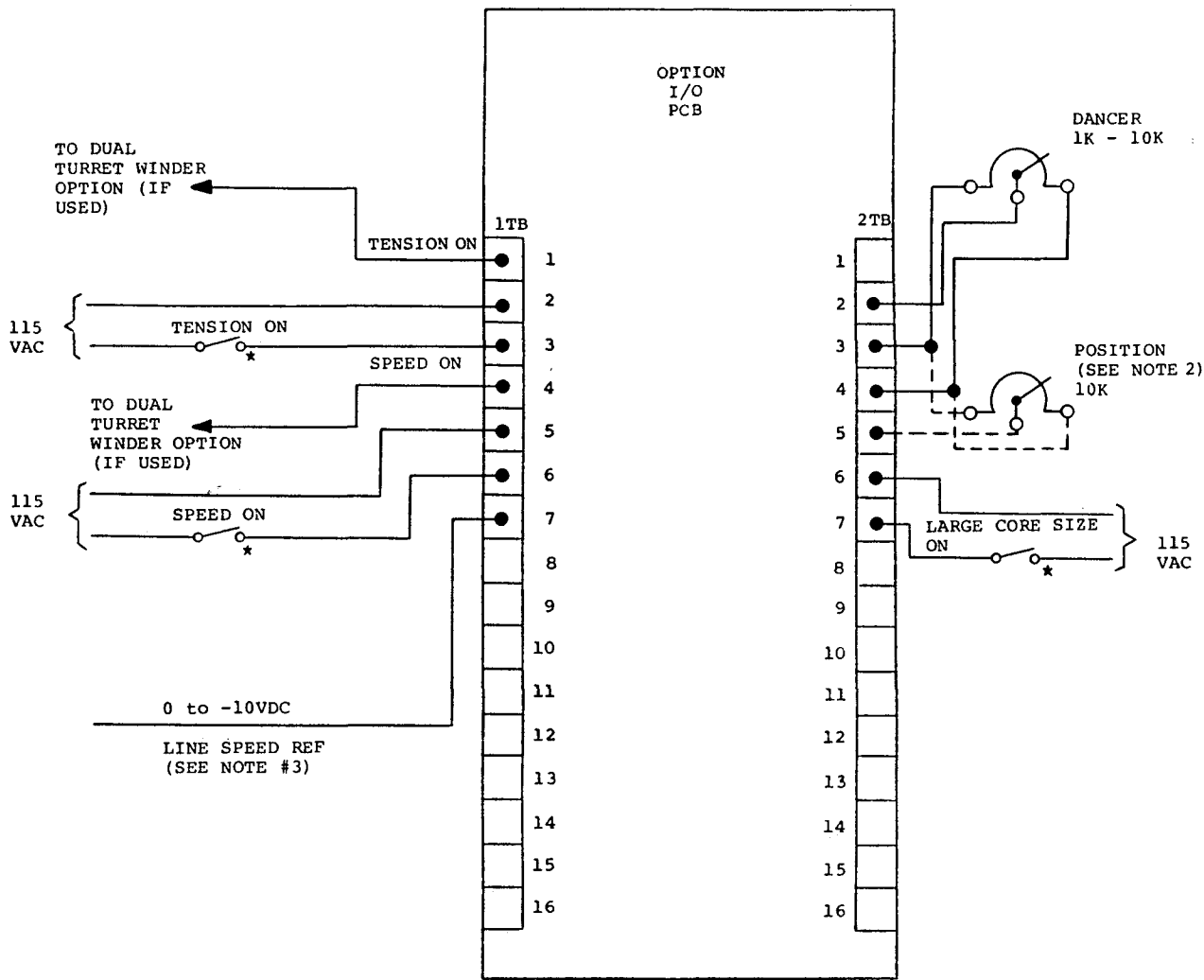

**NOTES:**

1. \* Indicates relay logic switch.
2. If external position pot is used, 1SS on function PCB MUST BE open.
3. -1160 Assembly Only: If line speed ref signal is used, 3SS on function PCB MUST BE open.

Figure 2. Interconnection Diagram

DWG. NO. 02Y00025-0071  
 SHEET 4 OF 6  
 EFF. 8/26/86 (L)

turn the ANTI-HUNT potentiometer (5RH) CW or reduce the PROPORTIONAL GAIN potentiometer setting to maintain a stable condition.

5. Increase the setting on the ANTI-HUNT potentiometer until the dancer fluctuations stop. If hunting persists at 100% setting, reduce setting to 50% and increase MAX ANTI-HUNT (10RH) until the fluctuations stop. Whenever the PROPORTIONAL GAIN potentiometer is adjusted, the ANTI-HUNT pot may require re-adjustment.

6. Check the stability over the entire rewind roll diameter range, from core to full roll.

7. As the rewind roll builds up, the dancer may move significantly off its maintained (regulated) position as set at core, especially if PROPORTIONAL GAIN had to be set low. This can be corrected by closing 2SS to enable the integral channel. Usually this will not interfere with any previous adjustments. In some cases, however, re-adjustment of PROPORTIONAL GAIN and ANTI-HUNT may be necessary. In rare cases, 2SS must be left open to assure stability.

8. In dual turret applications, the use of 2SS and the integral channel may cause loose tension on the first few wraps on a core after a flying splice transfer. If this occurs, perform the following procedure. a) Open 2SS, run the drive in TENSION at core, and measure and record the voltage at 6TP. b) Close 2SS and wind a roll on the other rewind to approximately 2/3 of full roll diameter. c) Then slowly adjust the TRANSFER POSITION pot on the other rewind assembly until 6TP (on the first rewind assembly) measures the same as the previously recorded value. d) Repeat for both rewinds.

9. If desired action cannot be obtained, perform option troubleshooting procedures.

## TROUBLESHOOTING

If other options have been installed, troubleshoot them thoroughly before discarding this assembly as faulty.

Troubleshooting consists of checking the input and output voltages of the assembly while the potentiometers are rotated.

1. Place the DANCER potentiometer to mid range (50%), and close the external TENSION ON relay logic switch.

2. Refer to the schematic diagram of the Dancer Position Winder Option and check the voltage at 1TP. Voltage should vary from 0 VDC to +9.88 VDC  $\pm 10\%$  as the DANCER potentiometer is moved over its entire range. If voltage is incorrect or erratic, check wiring and/or replace the DANCER potentiometer.

3. Check voltages at 2TP and 3TP. Voltage should go positive and negative as the DANCER potentiometer is moved about its normal regulated position. The actual voltage change at 3TP depends on the setting of the PROPORTIONAL GAIN potentiometer. The higher the setting, the larger the voltage swing for the same DANCER movement (maximum swing  $\pm 14$  VDC). If voltages do not vary with change in DANCER potentiometer, replace the Dancer Position Winder Option.

4. Check voltages at 4TP and 5TP. Voltage at 4TP should slowly follow position of the DANCER potentiometer. Increasing the setting of the TRANSFER POSITION potentiometer slows down the response time. Voltage at 5TP should depend on the rate the DANCER potentiometer is changed. The higher the setting of the ANTI-HUNT potentiometer, the larger the voltage swing for the same rate of change of the DANCER position. If the voltages do not vary with changes in the DANCER potentiometer, replace the Dancer Position Winder Option.

DWG. NO. 02Y00025-0071  
SHEET 5 OF 6  
EFF. 8/26/86 (L)

MODIFICATION RECORDS

After completing installation of this option, insert this instruction sheet immediately behind the front cover of the Controller instruction manual.

DWG. NO. 02Y00025-0071  
SHEET 6 OF 6  
EFF. 8/26/86 (L)