

For use with LANCER JR. TYPE VT
 General Purpose AC Inverter Drives.
 This kit is for drives rated 7-1/2
 to 20HP, 230V or 460 VAC.

3-15 PSIG FOLLOWER MOD KIT

-SPEED PROPORTIONAL TO PRESSURE

MODEL 92300 46S02674-0010

DESCRIPTION

This Louis Allis kit includes all the material described in Table 1 and illustrated in Figure 1.

The installation of this kit will allow the drive to accept a 3-15PSIG air signal, converting it to a proportional DC voltage which is used as the speed signal in the Auto mode of operation. This modification is compatible for use with the Internal Operator Control Station (OCS) plate devices as well as with a drive modified with one of the Louis Allis Remote Command Run Relay mod kits.

Before installing this kit, a **TECHNICALLY QUALIFIED INDIVIDUAL**, who is familiar with this type of equipment and hazards involved, should **READ** this **ENTIRE MANUAL**.

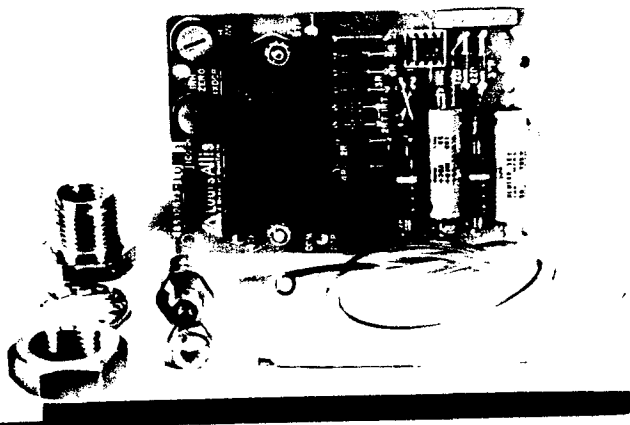

Table 1. Kit Contents

QTY.	DESCRIPTION	PART NUMBER
1	Transducer/Signal Conditioner PCB	46S02673-0010
1	Brass Bulkhead Adapter (1/4"-18NPTF)**	05P00070-0147
1	Brass Male Tube Fitting Connector	05P00070-0120
1	1/4" O.D. PVC Tubing (24 inches)	D.E.P. 13I.2.97
1	PCB Extracting Tool w/user Instr.	05P00065-0058
1	TY-RAP 8"	

** User must provide connector between adapter and air supply.

CHANGE RECORD	DWG. NO. 02Y000 J185
1 STD 2504 3/19/86	SHEET 1 OF 7
2 STD-2774 3-21-87 RCR	EFF. 3/19/86 (B)

IMPORTANT

THIS KIT MAY HAVE BEEN INSTALLED BY THE FACTORY. HOWEVER, CERTAIN STEPS CAN ONLY BE COMPLETED AT THE INSTALLATION SITE. THEREFORE, REVIEW AND THEN PERFORM THOSE STEPS WHICH DESCRIBE HOW TO GAIN ACCESS TO THE MODIFICATION BOARD. THEN COMPLETE INSTALLATION PROCESS STARTING WITH STEP 18.

INSTALLATION

1. Disconnect all electrical power to drive.
2. Open drive front cover.
3. Verify voltage has been disconnected by using a voltmeter to check for voltage at incoming power terminals.

WARNING

HAZARDOUS VOLTAGE CAN CAUSE SEVERE INJURY OR DEATH.

LOCK ALL POWER SOURCES FEEDING DRIVE IN "OFF" POSITION.

4. See Figure 2. Layout and drill the one (1) 0.75 diameter hole in bottom end of drive enclosure. Remove all drill scraps from enclosure.
5. See Figure 3. Assemble bulkhead adapter to bottom end of drive enclosure.
6. While manually holding the outside of the bulkhead adapter, tighten the 1-1/8" nut with a wrench until star lockwasher is compressed against inside of enclosure.
7. Thread the male tube fitting connector into the female thread of the bulkhead adapter until finger tight. Use a 9/16" open end wrench and tighten an additional one-quarter turn.

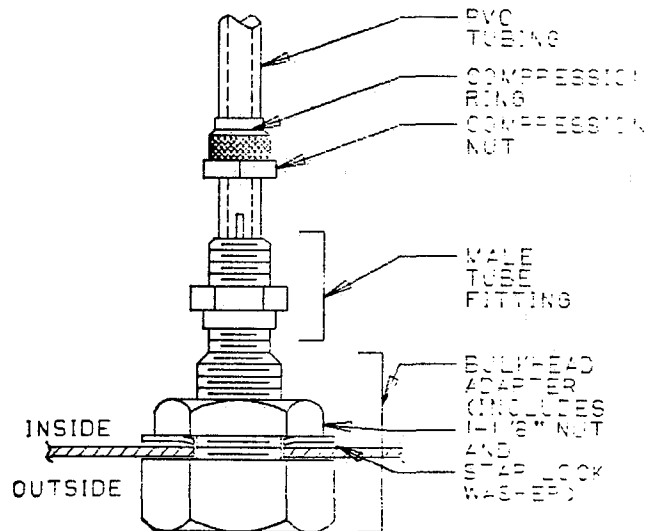
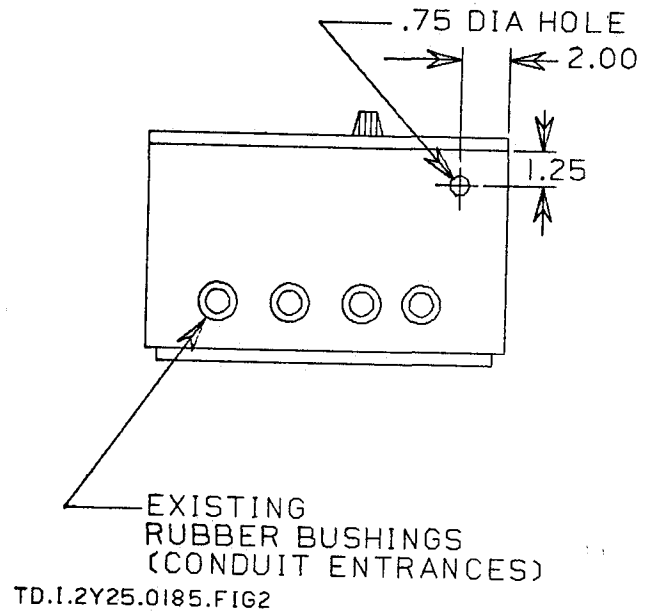

DWG. NO. 02Y00025-0185
SHEET 2 OF 7
EFF. 3/19/86

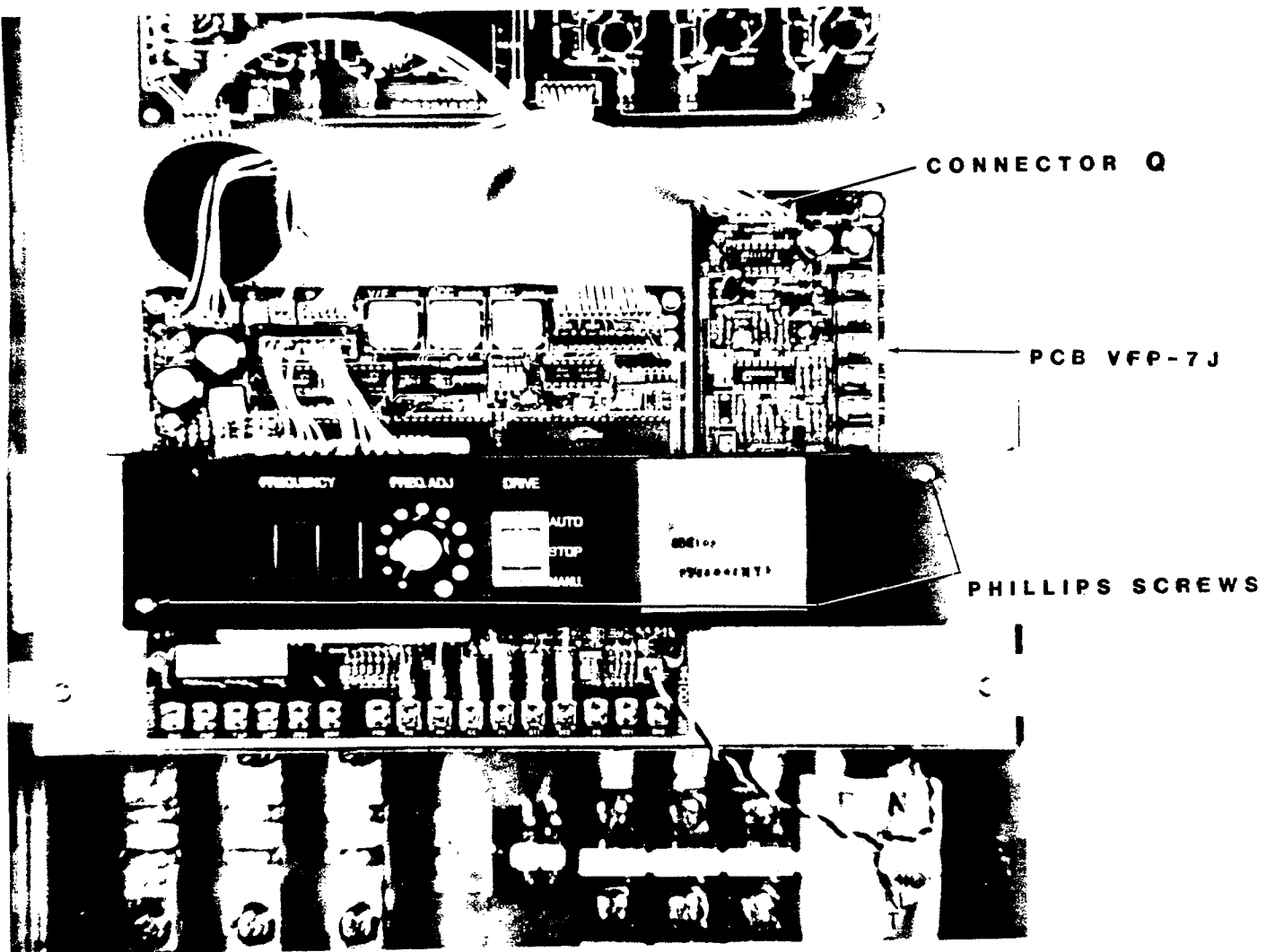

Figure 4. Component Location

8. See Figure 4. Remove and retain both Phillips screws which secure OCS plate to bracket. Carefully move it aside to expose PCB, part numbered VFP-7J.

9. Remove female connector designated "Q" from board.

10. Carefully remove the board from its four stand-offs using the supplied extraction tool. Ensure that stand-offs remain SECURED to drive chassis. Discard PCB board.

DWG. NO. 02Y00025-0185
 SHEET 3 OF 7
 EFF. 3/19/86

11. See Figure 5. Connect 1/4" O.D. PVC tubing to the input port of the Transducer/Signal Conditioner PCB. Once installed, secure PVC tubing to input port using supplied TY-RAP.

IMPORTANT

Securely hold and support the PCB board while connecting the PVC tubing. Applying excessive pressure while completing this connection may cause board flexing, resulting in cracking or damage.

If "dry" tubing will not slip onto fitting, it may be lubricated with a SMALL amount of water or SILICONE OIL. If used, it MUST NOT be allowed to ENTER the input port hole.

12. See Figure 7. Mount and secure Transducer Signal Conditioner PCB to the four existing stand-offs, ensuring that connector 1CONN is positioned at upper left.

IMPORTANT

Connector 1CONN is NOT POLARIZED. Verify location of Pin 1 on both connectors before completing Step 13.

13. See Figure 6. Insert female connector designated "Q" into 1CONN on board.

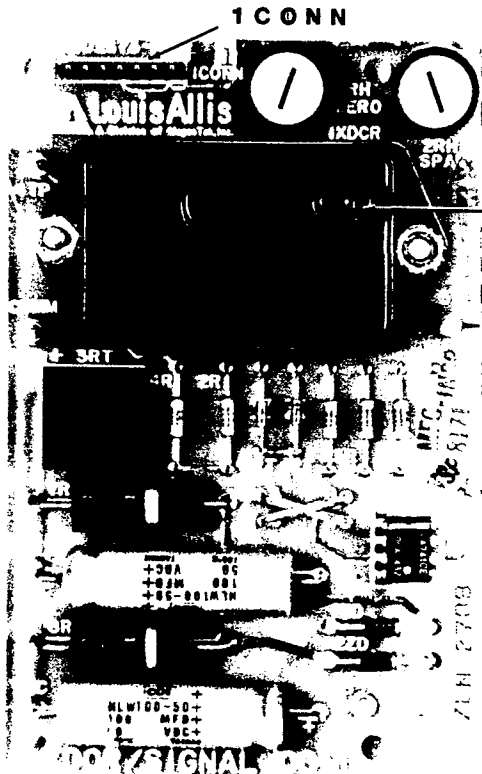

INPUT PORT

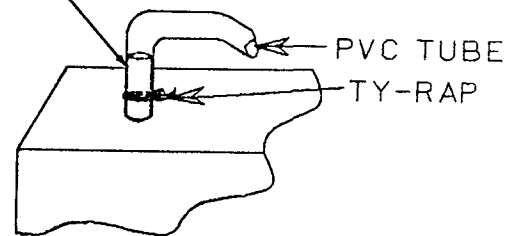
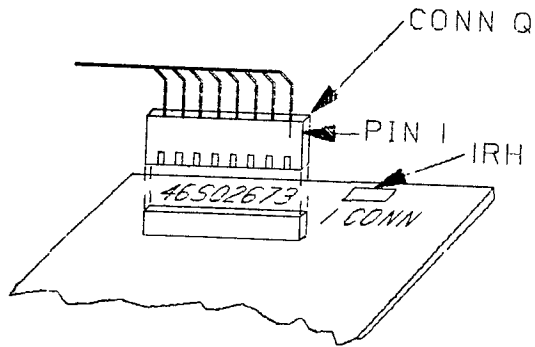

FIGURE 5A

TD 1.2Y25.0169 FIG5A

Figure 5. Transducer/Signal Conditioner PCB

DWG. NO. 02Y00025-010
SHEET 4 OF 7
EFF. 3/19/86



TD.1.2Y25.0185.F166

Figure 6. Connector Orientation

14. See Figure 7. Route PVC tubing as shown to the bulkhead connector at bottom of drive enclosure. Allow for slight loop at PCB end.

15. Remove the 7/16" compression nut from the male tube fitting connector. Squarely cut end of PVC tubing to proper length and insert tubing through the compression nut and plastic compression ring, pushing tube into fitting as far as possible.

16. Tighten the compression nut finger tight onto the male fitting. Then, use a 7/16" open end wrench and tighten an additional one-half turn only.

17. Re-install and secure OCS plate.

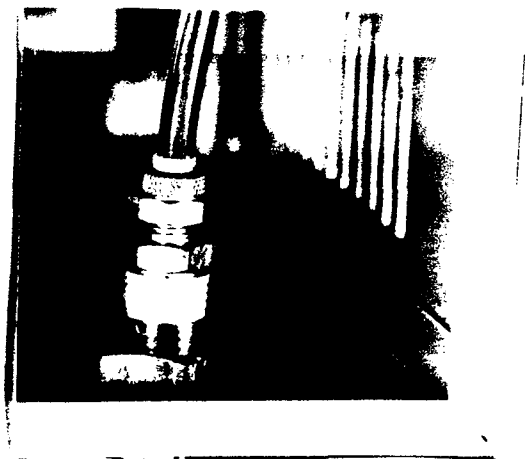
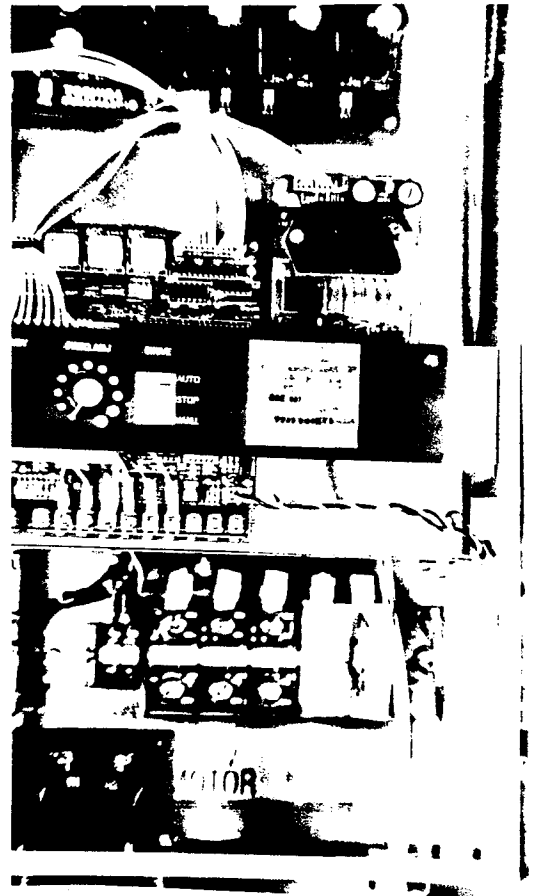

Figure 7. PVC Tube Routing

DWG. NO. 02Y00025-C1-
SHEET 5 OF 7
EFF. 3/19/86

FINAL ASSEMBLY

18. Connect the external air supply to the bulkhead fitting (1/4"-18NPTF) at bottom of drive enclosure.

IMPORTANT

Complete Step 19 ONLY IF the drive has been modified to include a Remote Command Run Relay. If it does not, go directly to Step 20.

19. See Figure 8.

a. If application requires a MAN/AUTO function, ADD an EXTERNAL SWITCH as shown in Figure 8A.

b. If application DOES NOT require a MAN/AUTO function, ADD a JUMPER as shown in Figure 8B.

ADJUSTMENTS

20. Complete adjustments specified in drive instruction manual.

Manual Mode: (If applicable)

21. Run the drive in the manual mode. Observe the OCS Plate FREQUENCY/FAULT meter and record both minimum and maximum frequency settings:

MINIMUM FREQ _____

MAXIMUM FREQ _____

After recording values turn drive OFF.

Auto Mode:

22. At Transducer/Signal Conditioner PCB, set 1RH (ZERO) and 2RH (SPAN) pots to 50%.

NOTE

These settings approximate a minimum inverter output of 3HZ at 3PSIG and a maximum output of 60HZ at 15PSIG.

23. Place MAN/AUTO selector switch to AUTO.

24. Initiate the drive run command and then apply the minimum (3PSIG) air signal.

25. Observe OCS Plate FREQUENCY/FAULT meter and adjust 1RH to obtain desired minimum drive output frequency.

Turning 1RH CW reduces drives' minimum output frequency.

26. Apply maximum (15PSIG) air signal.

27. Observe OCS Plate FREQUENCY/FAULT meter and adjust 2RH to obtain desired maximum drive output frequency.

Turning 2RH CW increases drives' maximum output frequency.

28. Both 1RH and 2RH adjustments interact. Repeat Steps 25 thru 27 until desired operation is attained.

29. Close drive front cover.

30. Place these instructions directly behind front cover of instruction manual.

This completes installation of this modification kit.

DWG. NO. 02Y00025-0185
SHEET 6 OF 7
EFF. 3/19/86

INVERTER CONTROL TERMINALS

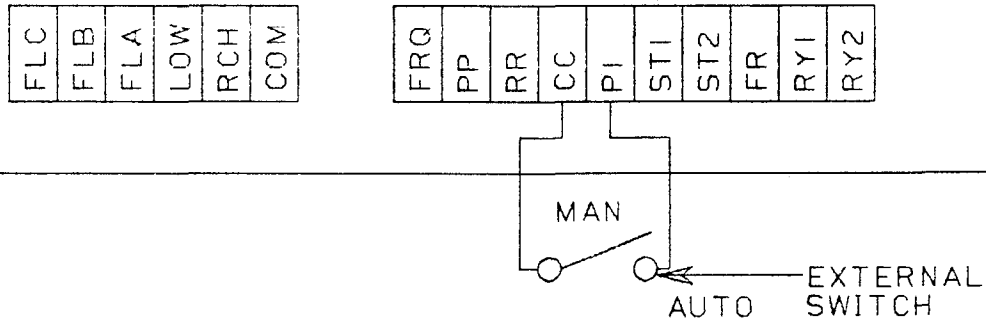

TD.I.2Y25.0185.F1G8.B

Figure 8A. MAN/AUTO Function Included

INVERTER CONTROL TERMINALS

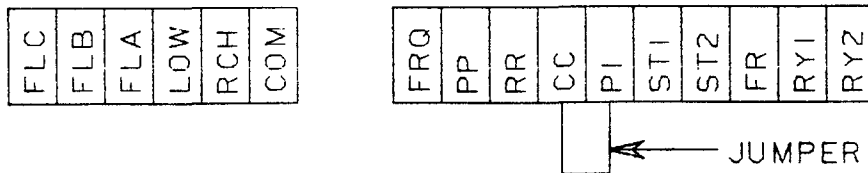

TD.I.2Y25.0185.F1G8.A

Figure 8B. MAN/AUTO Function NOT Included

DWG. NO. 02Y00025-0185
SHEET 7 OF 7
EFF. 3/19/86

