

Spindle Orientation Software

FLASH Memory Software Option (114740)

Part Number: GPD515C-ZZZZ-CS104⁽¹⁾

Software Revised: 07/21/00

This software enhances a GPD515 AC drive with the ability to control the stopped position of the motor's shaft; the targeted application is for spindle equipment with automatic tool changers. Orientation is achieved by processing feedback from a quadrature encoder connected to the spindle shaft. The positioning is based on a defined zero point which may be the marker pulse from the encoder or a switch.

The enhancements provided include:

Open Loop Vector Operation

The drive may be used without an encoder attached to the motor, the feedback encoder can be used on the spindle.

Closed Loop Vector Operation

The drive may be used with an encoder attached for better low speed control and positioning characteristics. This provides for better control when using the gearing option. If the motor is not directly coupled to the spindle shaft or gearing is used a feedback encoder on the spindle is required.

Gearing Ratio

The spindle to motor ratio may be adjusted between 1:10 to 10:1. This option may be used with open loop control, although closed loop control provides better performance.

Orient Command Input

This input initiates the orientation process and will stop the shaft in the desired position.

Marker Pulse Input

This input is provided through the PG option card. The marker or Z pulse from the encoder may be used to identify actual position. An external switch may also use this input.

Marker Offset Parameter

This parameter contains the actual stopping position and is measured in the number of counts since the marker pulse.

Oriented Output

This output indicates that the spindle shaft is oriented.

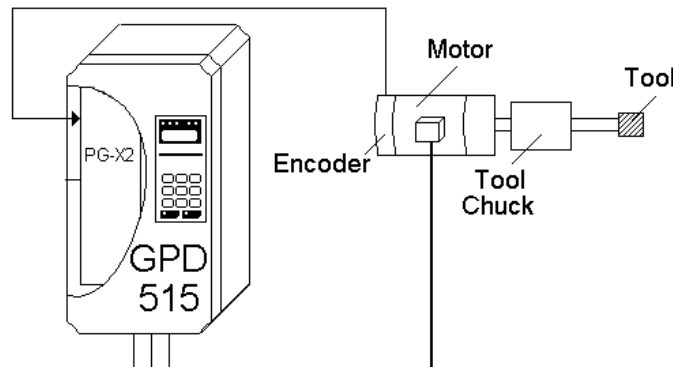

Two monitors are provided to indicate relative position to the marker and the angle relative to the orient position.

(1) ZZZZ refers to the base Model Number of the drive in which the software is installed.

This document is an addendum to the Technical Manual TM4515, listing the effect of this software on the parameters in the drive and the function descriptions in the manual.

Example Applications

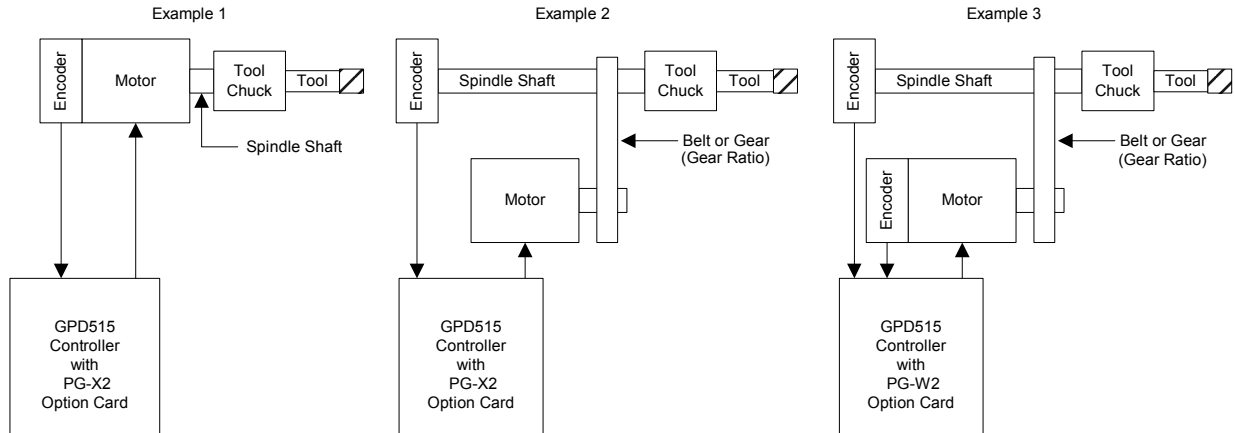

These examples show typical applications. In these examples the encoder Z or Marker pulse is used to indicate the zero position. An external switch may be used as the Marker pulse to indicate the zero position.

Example 1

This is a direct drive system where the encoder, motor and spindle shafts are directly coupled. This system can use the encoder for positioning and closed loop vector operation to provide the best performance.

Example 2

This is an indirect drive system where the motor to spindle shaft connection may change. This method also provides for gearing. The encoder is coupled to the spindle shaft to eliminate possible positioning errors. This method must use open loop vector speed control and will not provide the performance of a closed loop system.

Example 3

This is an indirect drive system where the motor to spindle shaft connection may change. This method also provides for gearing. The encoder is coupled to the spindle shaft to eliminate possible positioning errors. The encoder on the motor allows for closed loop vector speed control. This method will provide the best indirect positioning performance.

NOTE: This software requires a PG-X2 – Speed Control Card (MagneTek part # **DS003**) be installed on the drive for examples 1 and 2. For example 3 a PG-W2 – Dual Encoder Feedback Option Board (MagneTek part # **DS014**) is required.

1.0 Wiring

Wire the incoming power, motor, accessories and control wiring as specified in the GPD515 Technical Manual TM4515.

Wire the encoder(s) to the PG-X2 or the PG-W2 according to the instruction sheets 02Y00025-0398 or 02Y00025-0397 respectively.

NOTE: The +12V supply on the PG-W2 card is capable of only 200mA, be sure not to overload it.

1.1 Encoder Wiring Examples

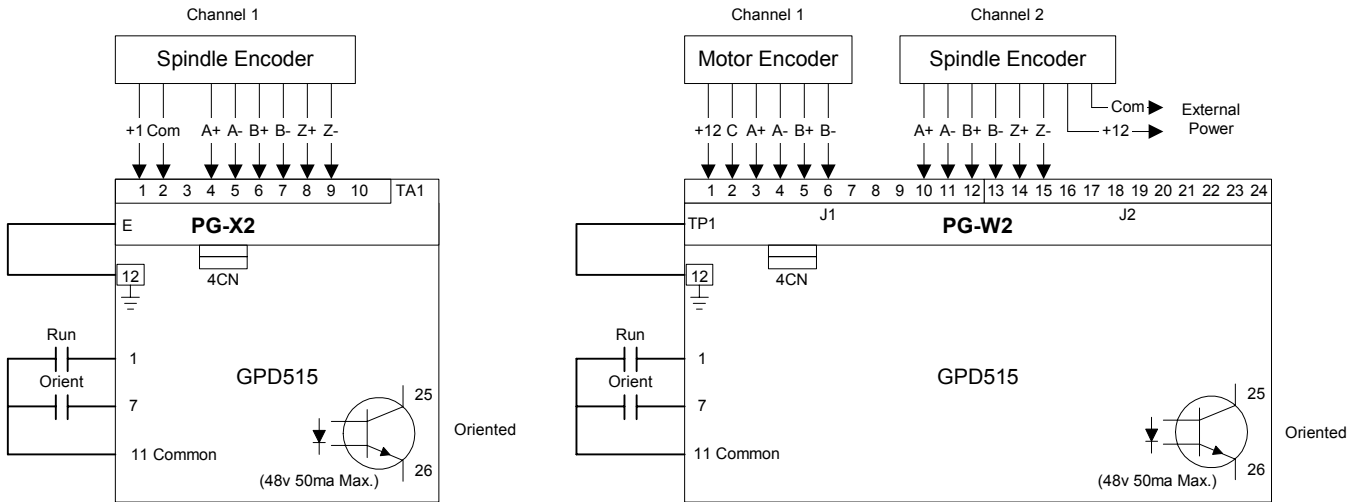

The diagrams shown indicate the default setup that will result from an initialize. The multifunction inputs and outputs may be redefined within the limits of the GPD515 to accommodate the application.

1.2 Marker Pulse Wiring Examples

If a proximity switch is going to be used as the marker pulse this is the recommended wiring.

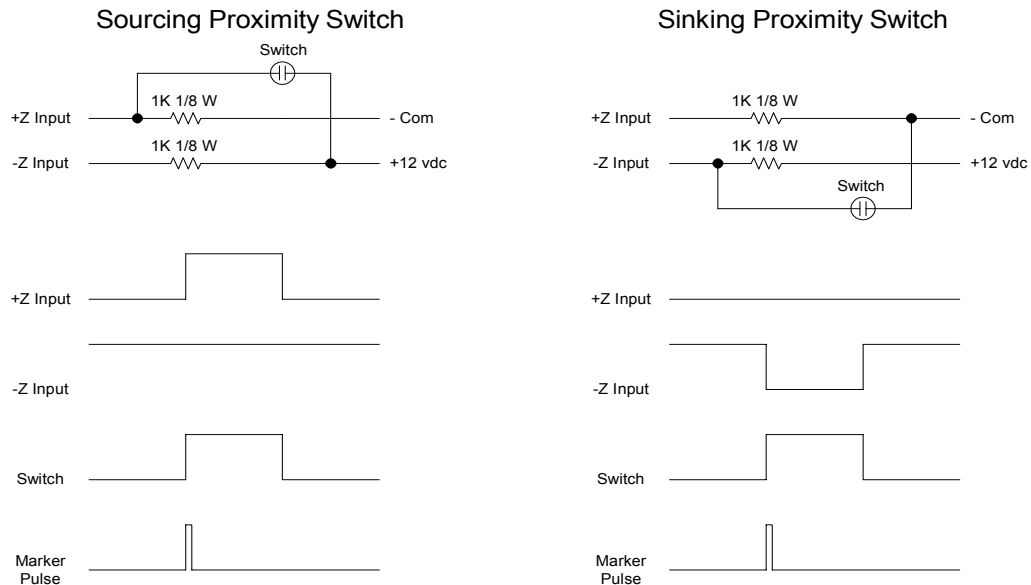

The diagrams show how either a sourcing or sinking proximity switch may be used to trigger the marker pulse. It is recommended that an external power supply be used to power the switching device.

2.0 I/O Definitions

2.1 New Multi-Function Digital Input Settings

For constants H1-01 through H1-06.

Setting	Display	Description
80	Orient Cmd	Command the drive to orient the spindle shaft

2.2 New Multi-Function Digital Output Settings

For constants F5-01 and F5-02, and H2-01 through H2-03.

Setting	Display	Description
40	Orient Complete	Turns on when the orientation command is complete.

2.3 New Multi-Function Analog Input Settings

For constants H3-05 through H3-09.

None

2.4 New Multi-Function Analog Output Settings

For constants F4-01, F4-03, H4-01, and H4-04.

None

3.0 Startup Procedure

The following startup guide is for example one, in which the drive is to be in closed loop vector and the motor and the spindle are directly coupled.

1. Perform the flux vector start-up procedure in Section 2.2b of the GPD515 Technical manual.
2. Select the encoder channel for spindle only (**P1-01** = 1).
3. Set the spindle encoder's Pulses Per Revolution (PPR) into parameter **P1-02**.
4. Set the Position Speed (**P1-04**). When an orient is commanded, the drive will decelerate down to the value set into parameter **P1-04**. A low value in parameter **P1-04** will increase orient time, a higher value will be more likely to overshoot.
5. Verify that one of the function terminals (H1-01 through H1-06) is set to Orient Cmd (80) (Typically H1-05, Terminal 7).

6. Set the Orient Offset (**P1-03**), which is the distance after the marker at which the motor will stop. The desired value may be found by running the drive and initiating the Orient command. When the drive stops remove the run input. Determine how far the spindle is from it's desired position. Change the value in **P1-03**. (A value equal to the pulses per revolution of the spindle encoder will result in ¼ revolution of the spindle). Repeat step 6 until desired stopping position is found.
7. To control the stop response use parameters **P1-06** and **P1-07**.
8. Done.

NOTE: the following factory default parameters/terminal assignments have changed:

C2-01 = 0.00 S curve set to zero (formerly 0.2).

C2-02 = 0.00 S curve set to zero (formerly 0.2).

C2-03 = 0.00 S curve set to zero (formerly 0.2).

H1-05 = 80 Terminal 7 is set to be the orientation command (formerly "Jog").

H2-02 = 40 Terminal 25 Orientation complete (formerly "Zero Speed").

4.0 Custom Software Parameters

4.1 New Program Group

Group P Spindle Orient

4.2 New Program Function

Function P1 Orient Settings

4.3 New Program Parameters

PG Channel
P1-01= 1

P2-01 PG Channel

Setting Range: 1 or 2
Factory Default: 1

Q	Q	Q	Q
---	---	---	---

Either channel 1 or 2 may be used for positioning. Set this for the channel that is connected to the positioning encoder. When a PG-X2 option card is used this setting must be 1. Channel 2 is only available with a PG-W2 option card.

Spindle PPR
P1-02= 1024 PPR

P1-02 Spindle Encoder PPR

Setting Range: 1 to 32767 Pulses per revolution
Factory Default: 1024 Pulses per revolution

Q	Q	Q	Q
---	---	---	---

Enter the pulses per revolution rating of the positioning encoder here.

Orient Offset
P1-03= 0

P1-03 Orient offset distance

Setting Range: 0 to 32767
Factory Default: 0

Q	Q	Q	Q
---	---	---	---

This parameter contains the number of quadrature counts offset past the marker that the shaft will travel before stopping. This is the Orient position. When this value is 0 the shaft will stop at the marker. The desired value may be found by running the drive and initiating the Orient command. When the drive stops remove the run input. The shaft should turn freely. Rotate the shaft to the desired position. Read the value of **U1-50** (Marker Offset) and enter it here.

The value of **U1-50** is a rolling counter ranging from 0 to the number of quadrature counts per revolution. The direction of rotation is irrelevant. The value indicates a relative position to the marker and is the same in either direction.

This value may also be used to add counts to the positioning algorithm. Adding the number of positioning encoder quadrature counts per revolution increases the stopping distance by one revolution.

Position Speed
P1-04= 0.10 HZ

P1-04 Position Speed

Setting Range: 0.00 to 10.00 Hertz
Factory Default: 0.10

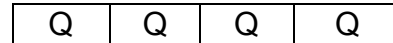

This parameter sets the minimum speed that may be used during positioning. This speed is also used when the shaft is within the number of quadrature counts set in **P1-05** (Position Count). If this speed is set to high the drive will oscillate when trying to hold the orient position. The positioning algorithm will decrease the speed until zero speed is reached at the orient position or this speed is reached and maintained until the orient position.

Position Count
P1-05= 0

P1-05 Position Count

Setting Range: 0 to 4096
Factory Default: 0

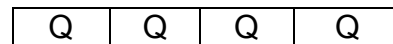

This parameter sets the number of quadrature counts before the orient position that the drive will hold the speed set in **P1-04** (Position Speed). This may be used to prevent overshooting the orient position. If this count is set to high the drive will slow down to soon and cause extended positioning times.

Stop Count
P1-06= 0

P1-06 Stop Count

Setting Range: 0 to 100
Factory Default: 0

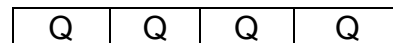

This parameter sets the number of quadrature counts before and after the actual orient position that will not result in a correction. This creates a stop range that prevents oscillation while the drive is in zero servo. The effect of this is dependent on the encoder resolution.

Stop Spd Gain
P1-07= 0

P1-07 Stop Speed Gain

Setting Range: 0 to 10
 Factory Default: 0

Q	Q	Q	Q
---	---	---	---

This parameter sets the frequency threshold where the positioning algorithm takes control of stopping the drive. It is based on a minimum threshold of 4.096 Hz with a 1 setting. The minimum threshold is multiplied by this value to achieve a maximum threshold of 40.96 Hz. This value also controls the rate of deceleration. The positioning algorithm will bring the drive to a stop in the orient position within 2 revolutions after initiated.

Spindle Ratio Num
P1-08= 1

P1-08 Spindle Ratio Numerator

Setting Range: 1 to 10
 Factory Default: 1

Q	Q	Q	Q
---	---	---	---

This parameter and **P1-09** (Spindle Ratio Div) must be set to the proper spindle to motor ratio. This ratio is required for the positioning to function properly.

Spindle Ratio Div
P1-09= 1

P1-09 Spindle Ratio Divisor

Setting Range: 1 to 10
 Factory Default: 1

Q	Q	Q	Q
---	---	---	---

This parameter and **P1-08** (Spindle Ratio Num) must be set to the proper spindle to motor ratio. This ratio is required for the positioning to function properly.

5.0 New Monitors

Shaft Angle U1-36 103.4°

U1-36 Shaft Angle

Displays the angle between the shaft position and the orient position. The display will indicate +/- 180 degrees.

Marker Offset U1-50 2303 cts

U1-50 Marker Offset

Displays the number of quadrature encoder counts the shaft is past the marker pulse. This is a rolling count and always indicates the relative position with respect to the marker. The counter values are controlled by the quadrature counts of the encoder used. A 1024 PPR encoder has a quadrature count of 1024 X 4 or 4096. Using this encoder this value will increment from 0 to 4095 in the forward direction. It will decrement from 4095 to 0 in the reverse direction. The 0 position indicated the marker.

6.0 New Alarm and Fault Codes

None