

(2) EXTERNAL COOLING FANS

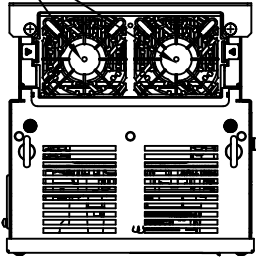

LIFTING AND EYEBOLT DETAILS

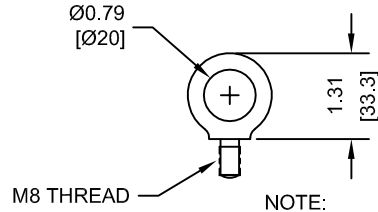

NOTE:  
SPREADER BAR REQUIRED TO AVOID DAMAGE DURING LIFTING

(4)-MOUNTING HOLES FOR 1/4" [M6] SCREWS

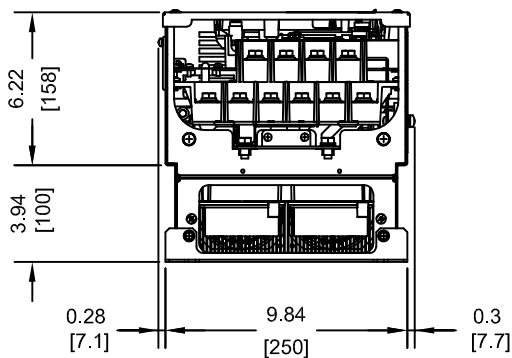
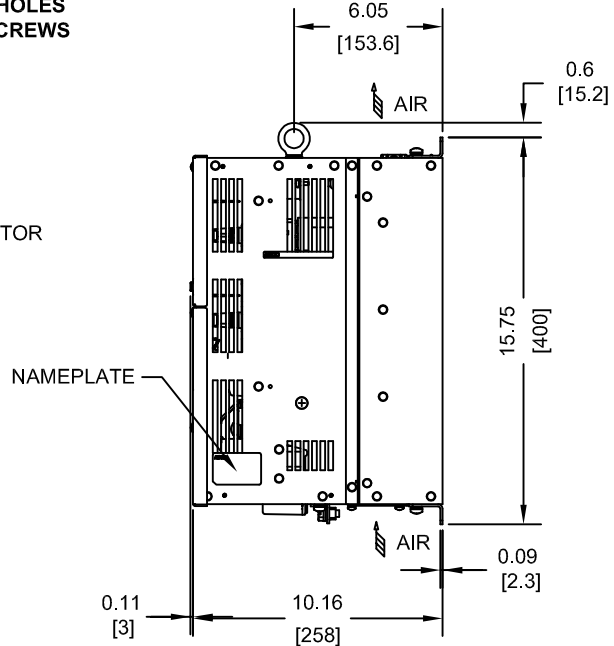
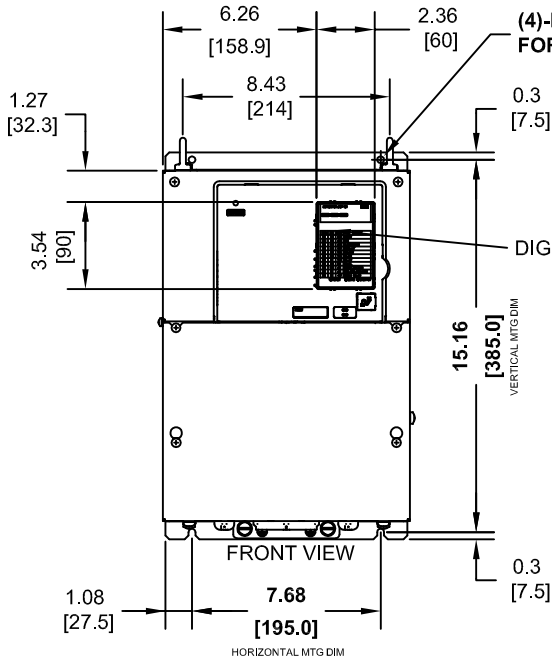

MODEL # CIMR-LE	VOLTAGE THREE-PHASE (VAC)	OUTPUT CURRENT (A) 3 MIN., 50% ED	WEIGHT LBS (Kg)	HEAT LOSS (W) Fc=8kHz		
				INT	EXT	TOT
2A0106DXX	200/240	106.3	46.2 (21)	211	510	721
4A0056DXX	380/480	56.3	46.2 (21)	170	349	519

NOTE:  
XX DENOTES AA-ZZ

INT=INTERNAL COMPONENTS  
EXT=EXTERNAL HEATSINK  
TOT=TOTAL

FOR ADDITIONAL DETAILS AND SPECIFICATIONS, CONSULT MANUAL

TOLERANCES / REFERENCES:		<p>THIS DOCUMENT AND INFORMATION CONTAINED IN IT ARE CONFIDENTIAL, AND CANNOT BE COPIED OR DISCLOSED IN WHOLE OR IN PART WITHOUT THE EXPRESS WRITTEN CONSENT OF YASKAWA AMERICA, INC.</p>	DRAWN: J. MATTAS CHECKED: J. PIOTROWSKI TECH: L. UDDIN APPROVED: J. CAIRO ORIGINAL DESIGN: -	DATE: 11-12-13 DATE: 11-24-13 DATE: 12-2-13 DATE: 12-21-13 DATE: -	TITLE: L1000E DIMENSION DRAWING FRAME SIZE 7 IP00 ENCLOSURE 2A0106 AND 4A0056
UNITS: IN [mm]	SCALE: 1:8		SIZE A	REVISION R00	PAGE 1 of 3
			DRAWING #: <b>DD.L1KE.FR7.IP00</b>		

TERMINAL AND WIRING DETAILS (SCALE 1:6)

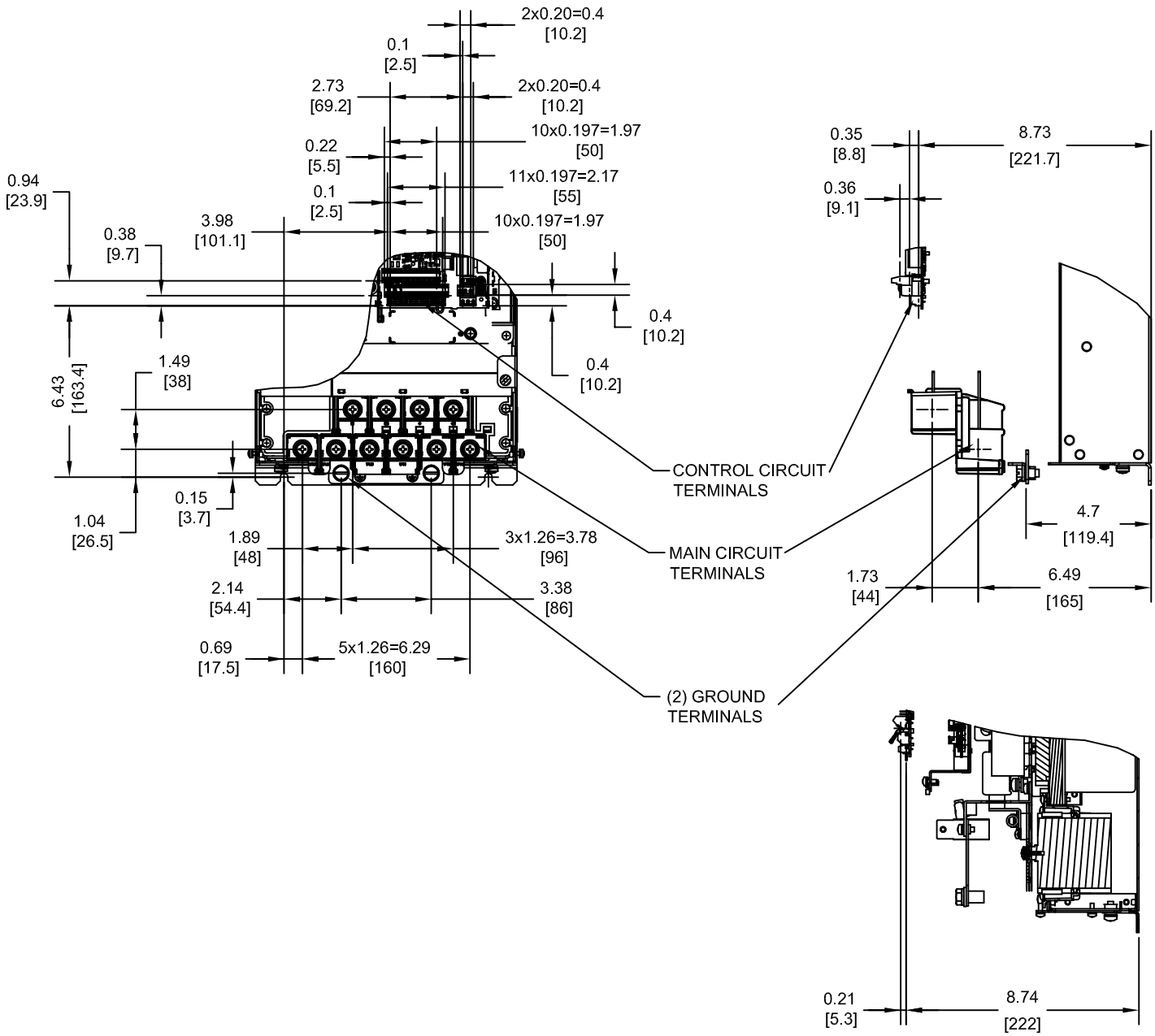

TERMINAL AND WIRE SPECIFICATIONS FOR MAIN CIRCUIT AND GROUND

SECTION A-A

MODEL # CIMR-LE	TERMINAL SYMBOL	TERMINAL SCREW	CLAMPING TORQUE lb.in.(N.m.)	WIRE RANGE AWG(mm <sup>2</sup> )
2A0106 4A0056	R/L1, S/L2, T/L3	M8	79.7 TO 97.4 (9 TO 11)	10-1/0 (5.3-53.5)
	U/T1, V/T2, W/T3			
	⊖, ⊕1			
	B1, B2			
	⊕	M8	79.7 TO 97.4 (9 TO 11)	SEE NOTE

NOTE: REFER TO APPLICABLE CODES FOR PROPER WIRE TYPE AND SIZE

FOR ADDITIONAL DETAILS AND SPECIFICATIONS, CONSULT MANUAL

TOLERANCES / REFERENCES:			DRAWN: J. MATTAS DATE: 11-12-13	TITLE: L1000E DIMENSION DRAWING FRAME SIZE 7 IP00 ENCLOSURE 2A0106 AND 4A0056
UNITS: IN [mm]	SCALE: BY VIEW		CHECKED: J. PIOTROWSKI DATE: 11-24-13	TECH: L. UDDIN DATE: 12-2-13
THIS DOCUMENT AND INFORMATION CONTAINED IN IT ARE CONFIDENTIAL, AND CANNOT BE COPIED OR DISCLOSED IN WHOLE OR IN PART WITHOUT THE EXPRESS WRITTEN CONSENT OF YASKAWA AMERICA, INC.		APPROVED: J. CAIRO DATE: 12-21-13	ORIGINAL DESIGN: - DATE: -	DRAWING #: <b>DD.L1KE.FR7.IP00</b>

MINIMUM INSTALLATION CLEARANCES (SCALE 1:4)

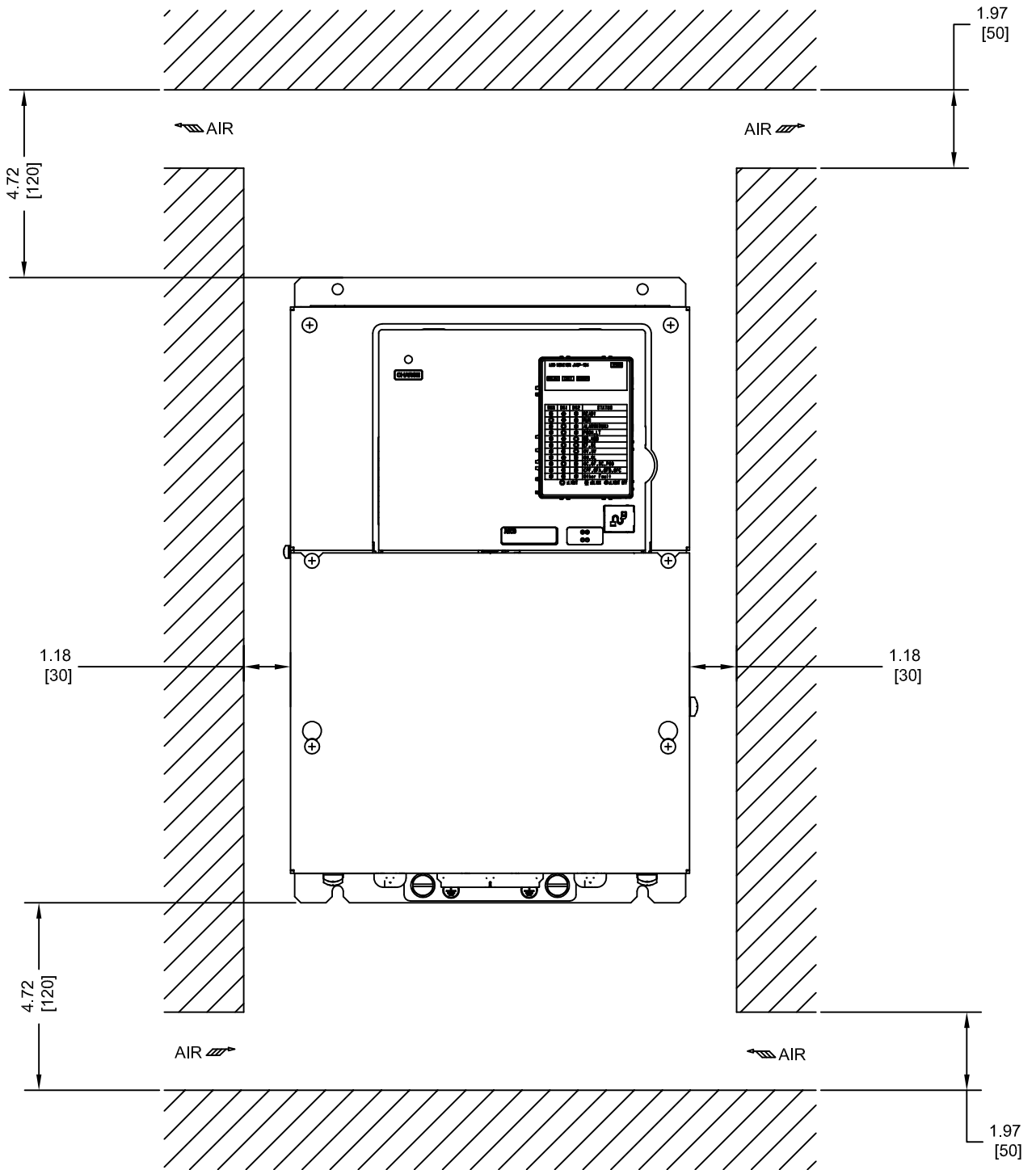

FOR ADDITIONAL DETAILS AND SPECIFICATIONS, CONSULT MANUAL

TOLERANCES / REFERENCES:		 THIS DOCUMENT AND INFORMATION CONTAINED IN IT ARE CONFIDENTIAL, AND CANNOT BE COPIED OR DISCLOSED IN WHOLE OR IN PART WITHOUT THE EXPRESS WRITTEN CONSENT OF YASKAWA AMERICA, INC.	DRAWN: <b>J. MATTAS</b>	DATE: 11-12-13	TITLE: L1000E DIMENSION DRAWING FRAME SIZE 7 IP00 ENCLOSURE 2A0106 AND 4A0056		
			CHECKED: <b>J. PIOTROWSKI</b>	DATE: 11-24-13	SIZE: A	REVISION: R00	PAGE: 3 of 3
			TECH: <b>L. UDDIN</b>	DATE: 12-2-13	DRAWING #: <b>DD.L1KE.FR7.IP00</b>		
			APPROVED: <b>J. CAIRO</b>	DATE: 12-21-13			
UNITS: IN [mm]	SCALE: BY VIEW	ORIGINAL DESIGN: -	DATE: -				