

UNI-WIRE INTERFACE MODULE DESCRIPTIVE INFORMATION

DISTRIBUTE I/O

MODEL: JAMSC-B2808, JAMSC-B2808-1
JAMSC-B2808-2, JAMSC-B2808T

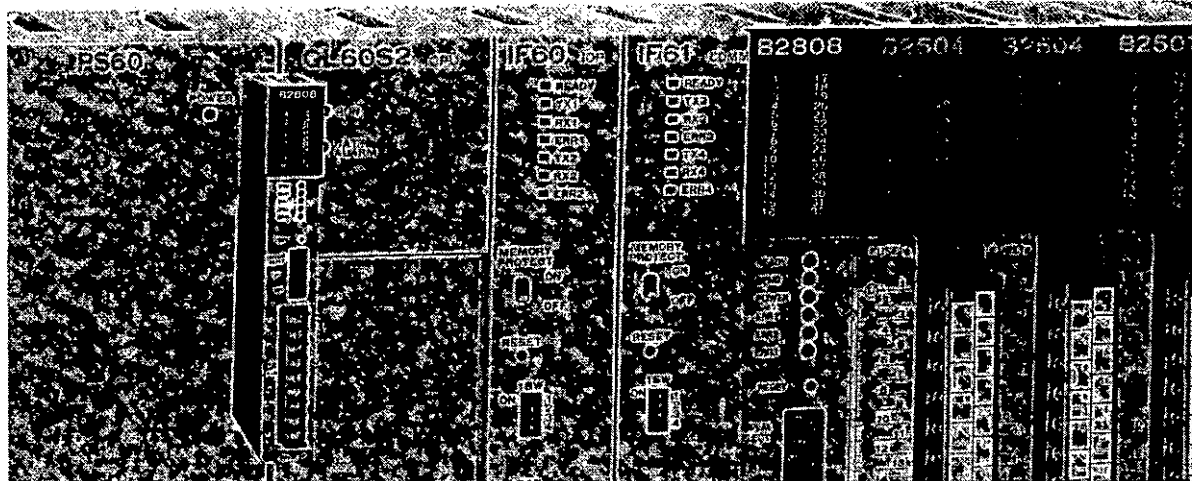

MANUAL CONTENTS

This manual describes wiring and cable selection of the UNI-WIRE Interface Module for the GL40S, GL60S, GL60H and GL70H PLCs.

Please read this manual carefully and be sure you understand the information provided before attempting to install or use the UNI-WIRE Interface Module.

NOTICE

The following conventions are used to indicate precautions in this manual. Failure to heed precautions provided in this manual can result in injury to people or damage to the products.



WARNING

: Indicates precautions that, if not heeded could possibly result in loss of life or serious injury.



CAUTION

: Indicates precautions that, if not heeded, could result in relatively serious or minor injury, damage to the product, or faulty operation.

CONTENTS

1	FEATURES AND SYSTEM CONFIGURATION	8
1.1	FEATURES	8
1.2	SYSTEM CONFIGURATION	8
2	SPECIFICATIONS	9
2.1	GENERAL SPECIFICATIONS	9
2.2	PERFORMANCE SPECIFICATIONS	9
3	PART NAMES AND CONNECTIONS	10
4	HOW TO USE	11
4.1	B2808, -1, -2 USAGE	11
4.2	I/O ALLOCATION AND SIGNAL PROCESSING ON UNI-WIRE SYSTEM	12
4.3	B2808 SETTING AND TYPICAL SETTING ON UNI-WIRE SYSTEM	13
4.4	B2808T USAGE	15
5	STATUS DISPLAY · TRANSMISSION DISTANCE	17
5.1	I/O STATUS DISPLAY SELECTION · TRANSMISSION DISTANCE SELECTION	17
5.2	LED DISPLAY AT FAULT OCCURRENCE	19
6	TYPICAL CONNECTIONS	21
7	TYPICAL SYSTEM CONFIGURATION	22
8	DIMENSIONS	26

* UNI-WIRE system is an NKE CO., LTD. product.

I.1 OVERVIEW OF MANUAL

- This manual describes wiring and cable selection of the MEMOCON-SC GL40S, GL60S, GL60H, GL70H.
- Read this manual carefully in order to use the UNI-WIRE system properly. Also, keep it in a safe place so that it can be used whenever necessary.
- Refer to the following manuals as necessary.

	Manual Name	Manual Number	Content
CPU Module	MEMOCON-SC GL60S DESCRIPTIVE INFORMATION	SIE-C815-14.1	Describes system configuration devices and their functions, specifications, application methods, etc., for the MEMOCON-SC GL60S.
	MEMOCON-SC GL40S DESCRIPTIVE INFORMATION	SIE-C815-15.1	Describes system configuration devices and their functions, specifications, application methods, etc., for the MEMOCON-SC GL40S.
	MEMOCON-SC GL60H, GL70H DESCRIPTIVE INFORMATION	SIE-C815-17.1	Describes system configuration devices and their functions, specifications, application methods, etc., for the MEMOCON-SC GL60H/GL70H.
Man/ Machine Interface	MEMOCON-SC GL60S P150 PROGRAMMING PANEL DESCRIPTIVE INFORMATION	SIE-C815-14.2	Describes functions, specifications, application methods, etc., for the P150 PROGRAMMING PANEL.
	MEMOCON-SC GL60S, GL60H, GL70H P150 PROGRAMMING PANEL DESCRIPTIVE INFORMATION	SIE-C815-14.3	Describes the SFC functions, specifications, application methods, etc., for the P150 PROGRAMMING PANEL.
	MEMOCON-SC GL40S P150 PROGRAMMING PANEL DESCRIPTIVE INFORMATION	SIE-C815-15.2	Describes functions, specifications, application methods, etc., for the P150 PROGRAMMING PANEL.

- Thoroughly check the specifications and conditions or restrictions of the product before use.

I.2 PRECAUTIONS

This section outlines general precautions that apply to using this manual and the product. You must read this section before reading the remainder of this manual.

I.2.1 SAFETY PRECAUTIONS

- MEMOCON-SC was not designed or manufactured for use in devices or systems that concern people's lives. Users who intend to use the product described in this manual for special purposes such as devices or systems relating to transportation, medical, space aviation, atomic power control, or underwater use must contact Yaskawa Electric Corporation beforehand.
- This product has been manufactured under strict quality control guidelines. However, if this product is to be installed in any location in which a failure of MEMOCON-SC involves a life and death situation or in a facility where failure may cause a serious accident, safety devices must be installed to minimize the likelihood of any accident.
- Any illustrations, photographs, or examples used in this manual are provided as examples only and may not apply to all products to which this manual is applicable.
- The products and specifications described in this manual or the content and presentation of the manual may be changed without notice to improve the product and/or the manual. A new version of the manual will be re-released under a revised document number when any changes are made.
- Contact your Yaskawa representative or a Yaskawa office listed on the back of this manual to order a new manual whenever this manual is damaged or lost. Please provide the document number listed on the front cover of this manual when ordering.
- Contact your Yaskawa representative or a Yaskawa office listed on the back of this manual to order new nameplates whenever a nameplate becomes worn or damaged.
- Yaskawa cannot make any guarantee for products which have been modified. Yaskawa assumes no responsibility for any injury or damage caused by a modified product

I.2.2 INSTALLATION PRECAUTIONS

CAUTION

- The installation environment must meet the environmental conditions given in the product catalog and manuals.

Using the MEMOCON-SC in environments subject to high temperatures, high humidity, excessive dust, corrosive gases, vibration, or shock can lead to electric shock, fire, or faulty operation. Do not use the MEMOCON-SC in the following location.

- Locations subject to direct sunlight or ambient temperatures not between 0 and 55 °C.
- Locations subject to relative humidity in excess of 95%, rapid changes in humidity, or condensation.
- Locations subject to corrosive or flammable gas.
- Locations that would subject the MEMOCON-SC to direct vibration or shock.
- Locations subject to contact with water, oil, chemicals, etc.
- Do not remove the cover of the connector where a module is not mounted. Foreign matter can cause malfunction in the MEMOCON-SC.
- Be sure all screws are tight. Malfunctions may occur as a result of loose screws.

I.2.3 WIRING PRECAUTIONS

CAUTION

- Connect a power supply complying with the rated specifications. A power supply that does not comply with the rating may cause a fire.
- Wiring must be performed by qualified personnel. Mistakes in wiring can cause fires, product failure, or malfunctions.
- When wiring, do not allow foreign matters such as wire shrapnel to enter the mounting base or the module. Foreign matter can cause fires, product failure, or malfunctions.
- Separate wiring properly.
 - I/O lines connecting external devices to the UNI-WIRE system must be selected based on the following considerations:
 - Mechanical strength, resistance to noise, wiring distance, signal voltage, etc.

 CAUTION

- I/O lines must be separated from power lines both inside and outside of the control panel to minimize the affects of noise. Faulty operation may occur if I/O lines are not sufficiently separated from power lines.

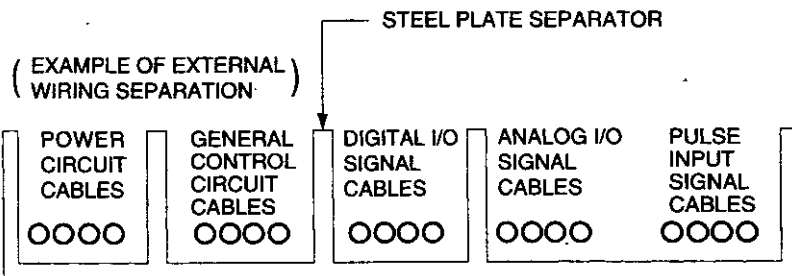

I.2.4 APPLICATIONS PRECAUTIONS

 CAUTION

- Operations such as RUN, STOP, program change and forced output must be carried out with care during operation.
Operational errors may damage the machine or cause accidents.

I.2.5 MAINTENANCE

 CAUTION

- Do not attempt to disassemble or modify the Module or Mounting Base in any way.
Doing so can cause fires, product failure, or malfunctions.

I.3 USING THIS MANUAL

This manual is written for those who already have a basic knowledge of MEMOCON-SC. We recommend reading the MEMOCON-SC GL40S, GL60S, GL60H, GL70H Descriptive Information before attempting to read this manual.

MEANING OF BASIC TERMS

In this manual, the following terms indicate the meanings as described below, unless otherwise specified.

- B2808, B2808-1 = UNI-WIRE Interface Module
B2808-2, B2808T
- PLC = Programmable (Logic) Controller
- PP = Programming Panel
- GL40S, GL60S = MEMOCON-SC GL40S, GL60S, GL60H, GL70H
GL60H, GL70H Programmable Controllers

1 FEATURES AND SYSTEM CONFIGURATION

1.1 FEATURES

- B2808 can be easily connected with the UNI-WIRE system by a single 2-core cable.
- I/O service of up to 128 points is available.
- The maximum number of slave stations: 20 stations
- The maximum total expanding distance: 200 m/500 m.
- A system can be constructed at a low cost because of reduced wiring.

1.2 SYSTEM CONFIGURATION

Fig. 1.1 shows a typical system configuration.

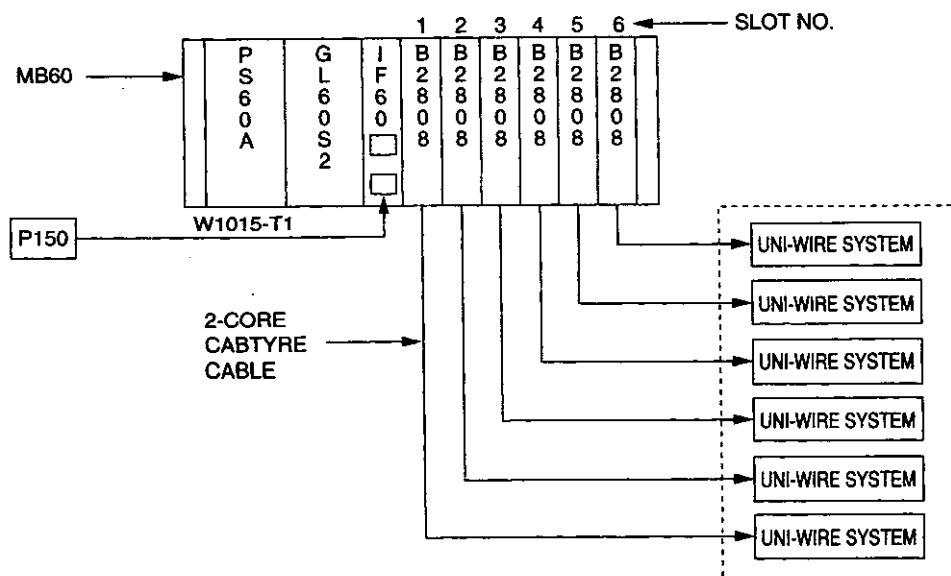

Name	Type	Remarks
UNI-WIRE Interface	JAMSC-B2808 , JAMSC-B2808-1 JAMSC-B2808-2 , JAMSC-B2808T	Inserted into 2000 series I/O slot. Note: B2808 is changed the model to B2808-1 or B2808-2.
UNI-WIRE System	(Refer to technical manual from NKE CO., LTD.)	To be supplied by Yaskawa Control.
CPU	DDSCR-GL20, GL40S, GL60S, GL60H, GL70H	
Main Power Supply	JRMSP-PS60	
Mounting Base	JRMSI-MB60	
Programming Panel	DISCT-P150-10	
Programming Panel Connection Cable	JZMSZ-W1015-T1	

Fig. 1.1 Typical System Configuration

2 SPECIFICATIONS

2.1 GENERAL SPECIFICATIONS

Table 2.1 General Specifications

Item	Specifications
Operating Ambient Temperature	0 to 55°C
Storage Temperature	-20 to 85°C
Humidity	30 to 95% RH (Non-condensing)
Vibration-resistance	Vibration range: 10 to 55 Hz Single amplitude: 0.075 mm Number of sweeps: 10 times
Shock-resistance	In compliance with JIS* C 0912
Environmental Condition	Free of flammable or corrosive gases

* Japanese Industrial Standard

2.2 PERFORMANCE SPECIFICATIONS

Table 2.2 Performance Specifications

Item	Specifications			
	B2808	B2808-1	B2808-2	B2808T
Type	B2808	B2808-1	B2808-2	B2808T
Communication Mode	Bidirectional multi method time division			
Synchronization	Bit synchronous			
Transmission Procedure	UNI-WIRE protocol			
Transmission distance (Total Distance)	200 m/500 m (Switch selection)	200 m	500 m	500 m
Refresh Time	At 200 m transmission distance: Approx. 13 ms At 500 m transmission distance: Approx. 26 ms	Approx. 13 ms	Approx. 26 ms	Approx. 52 ms
	(double verification time on UNI-WIRE system)			
Transmission Speed	At 200 m transmission distance: 28.5 kbps At 500 m transmission distance: 14.3 kbps	28.5 kbps	14.3 kbps	14.3 kbps
Transmission Cable	Cabtyre cable of 0.5 mm ² or more			
Number of Connectable Units	Maximum 20 units			Maximum 40 units
Maximum Transmission I/O Points	128 points	128 points	128 points	256 points
	(total value of bits for each of digital and register)			
Internal Current consumption	5 VDC, 0.3 A TYP			
External Power Supply	22.8 to 26.4 VDC, ripple 0.5 V P-P or less 0.2 A TYP (excluding power at UNI-WIRE system)			



1 B2808 is changed the model to B2808-1 or B2808-2.

2 Transmission distance cannot be selected for B2808-1, 2 and T.

3 PART NAMES AND CONNECTIONS

Example using B2808 is shown below.

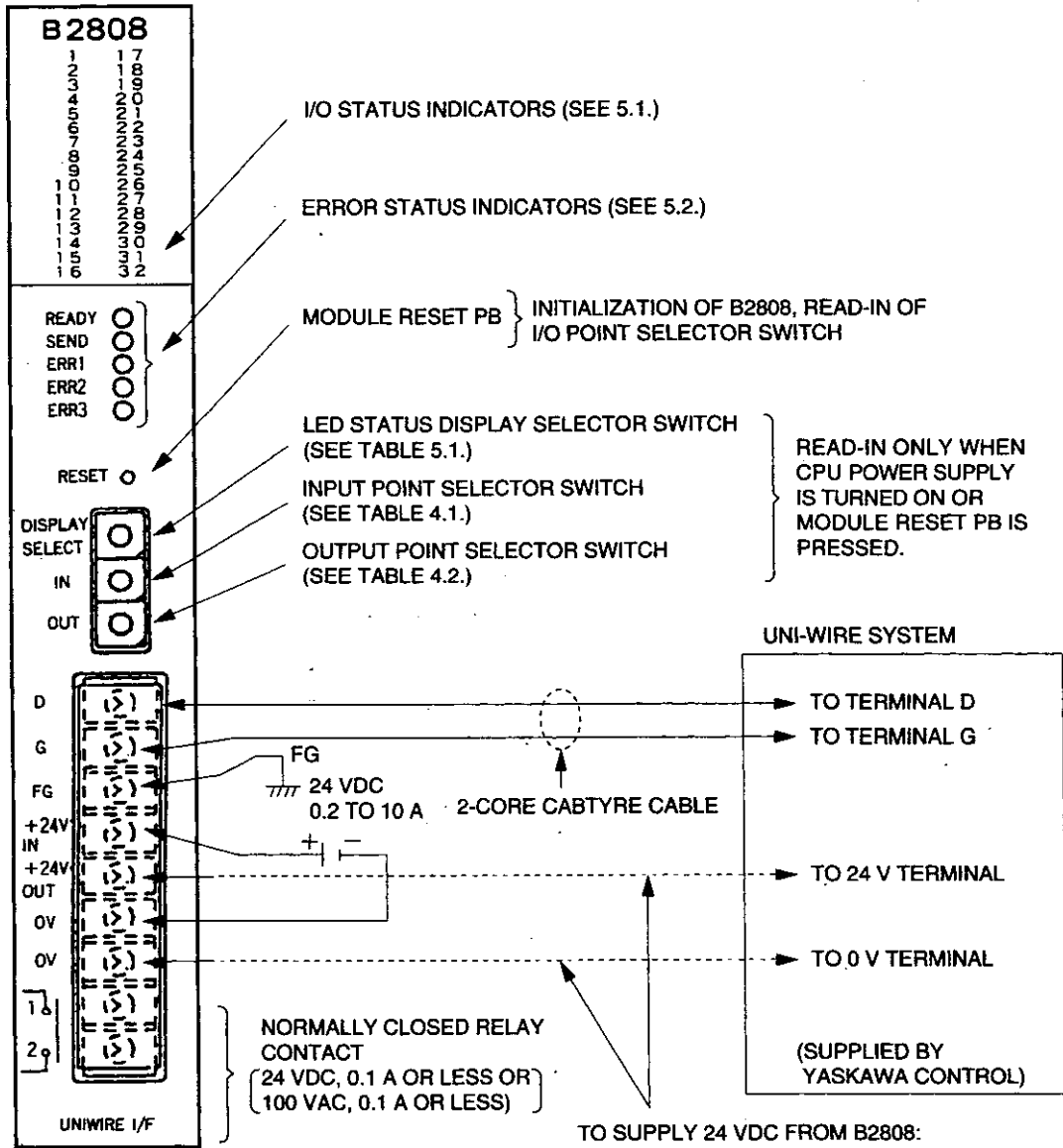

Pay attention to voltage drop at the ends when power supply cables extend over a long distance. If voltage drop is out of the allowable range (22.8 VDC or less), DC power supply must be provided separately.

4 HOW TO USE

4.1 B2808, -1, -2 USAGE

- ① Connect the B2808 with the UNI-WIRE system according to the procedures described in Chap. 6. For connection of UNI-WIRE system modules other than the AD-120, consult the UNI-WIRE SYSTEM TECHNICAL MANUAL from NKE CO., LTD.
- ② For I/O assignment to the CPU Module, at least one input register must be allocated in addition to the allocation for the UNI-WIRE system. The first input register allocated is used by the PC to monitor the status of the UNI-WIRE system. (See the NOTE in 4.2.)
- ③ Set the number of I/O points to be used by the UNI-WIRE system with the IN and OUT selector switches of the B2808 according to Tables 4.1 and 4.2. Always depress the reset button of the B2808 after making any changes to the I/O settings.

Table 4.1 Relation between Input Point Selector Switch and Input Points

Input Point Selector Switch	Number of Input Relays	Number of Register Sets (Points)
0	0	0
1	16	0
2	32	0
3	48	0
4	64	0
5	80	0
6	96	0
7	112	0
8	128	0
9	0	2 (32)
A	0	4 (64)
B	0	6 (96)
C	0	7 (112)
D	32	2 (32)
E	48	1 (16)
F*	Test mode (Prohibited)	

Table 4.2 Relation between Output Point Selector Switch and Output Points

Output Point Selector Switch	Number of Output Coils	Number of Register Sets (Points)
0	0	0
1	16	0
2	32	0
3	48	0
4	64	0
5	80	0
6	96	0
7	112	0
8	128	0
9	0	2 (32)
A	0	4 (64)
B	0	6 (96)
C	0	8 (128)
D	32	2 (32)
E	48	1 (16)
F*	Test mode (Prohibited)	

*Do not use this switch since it is for test mode only.



The total number of points selected by the IN and OUT selector switches can be no more than 128 points. I/O data is communicated in the order of input points, input registers, output points and output registers. I/O points exceeding 128 will be disregarded.

[Example] IN selector switch: 6 (96 input points)
 OUT selector switch: 6 (96 output points)
 $96 + 96 = 192$, therefore, 64 output points will be disregarded.

4.2 I/O ALLOCATION AND SIGNAL PROCESSING ON UNI-WIRE SYSTEM

The following describes I/O allocation to GL60S CPU, typical setting of I/O point selector switches in B2808 and signal processing.

[Example]

- I/O allocation to GL60S CPU
 - Input relay: 32 points (10001 to 10032)
 - Input register: 3 sets (30001* to 30003)
 - Output coil: 32 points (1 to 32)
 - Output register: 2 sets (40001 to 40002)
- Total 128 points
* The beginning of input registers (30001) is not added to the total I/O points since it is used for status information.

- Setting of I/O point selector switches in B2808 (See Tables 4.1 and 4.2.)
 - * Input point selector switch: D (input relay 32 points, input register 2 sets)
 - Output point selector switch: D (output coil 32 points, output register 2 sets)
- Total 128 points



* For allocation to CPU, one extra input register is added for status information. However, for selection at the UNI-WIRE system, select the required number of I/O points by the switch.

In the UNI-WIRE system, 128 points of signals (addresses 0 to 127) are always sent to output coils, output registers, input relays and input registers in this order from the starting number.

The registers are sent to the LSB side first.

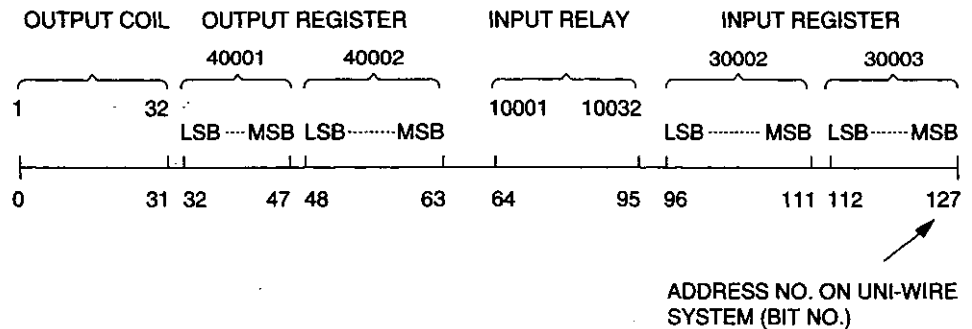

NOTE

The status information of UNI-WIRE system can be monitored by the lower 4 bits at the beginning of the input register. (30001 in the above figure.)

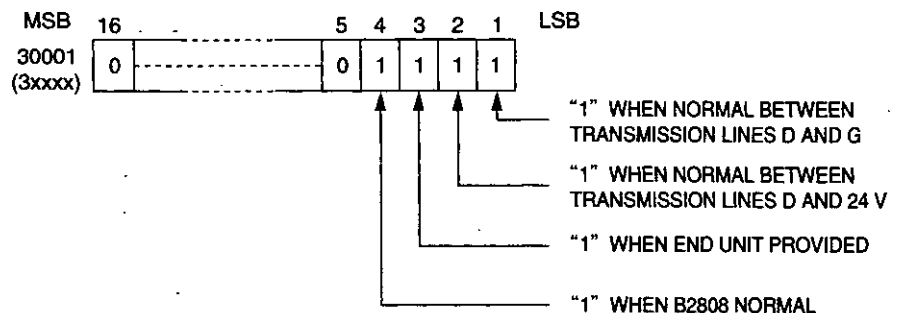

4.3 B2808 SETTING AND TYPICAL SETTING ON UNI-WIRE SYSTEM

[Example] · Setting of B2808-1 I/O point selector switches

Input point selector switch 4 (input relay 64 points)
Output point selector switch 4 (output coil 64 points)

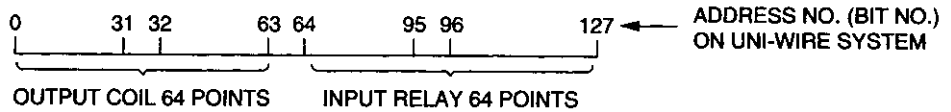

Output coils occupy 64 points in the order from the smallest address number, and input relays occupy the remaining.

[Typical setting and installation in UNI-WIRE system (At 200 m transmission distance (B2808-1))]

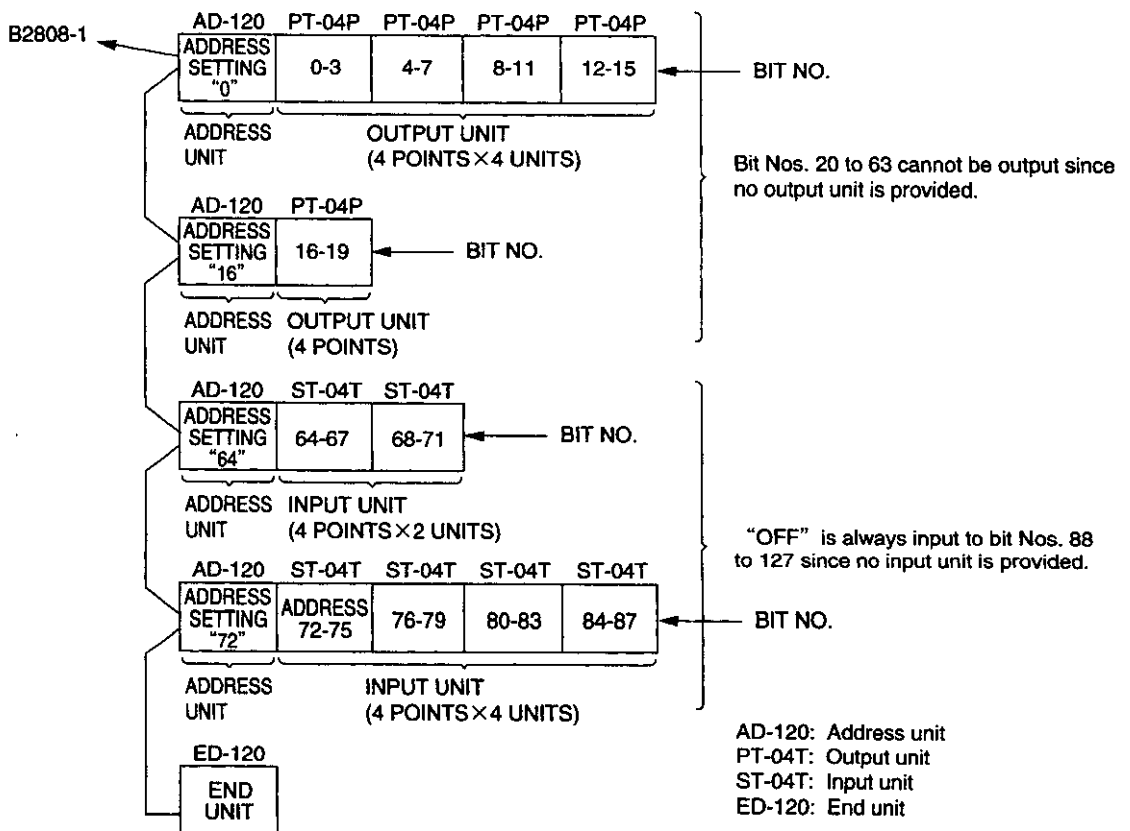

- 1 Do not overlap the bit No. on the UNI-WIRE system as shown in the example (poor example) on the next page.
- 2 When transmission distance is 500 m (B2808-2), a 500 m compatible UNI-WIRE system must also be used.

[Poor Example] (Setting of B2808-1 I/O point selector switches is to be the same as that in 4.3.)

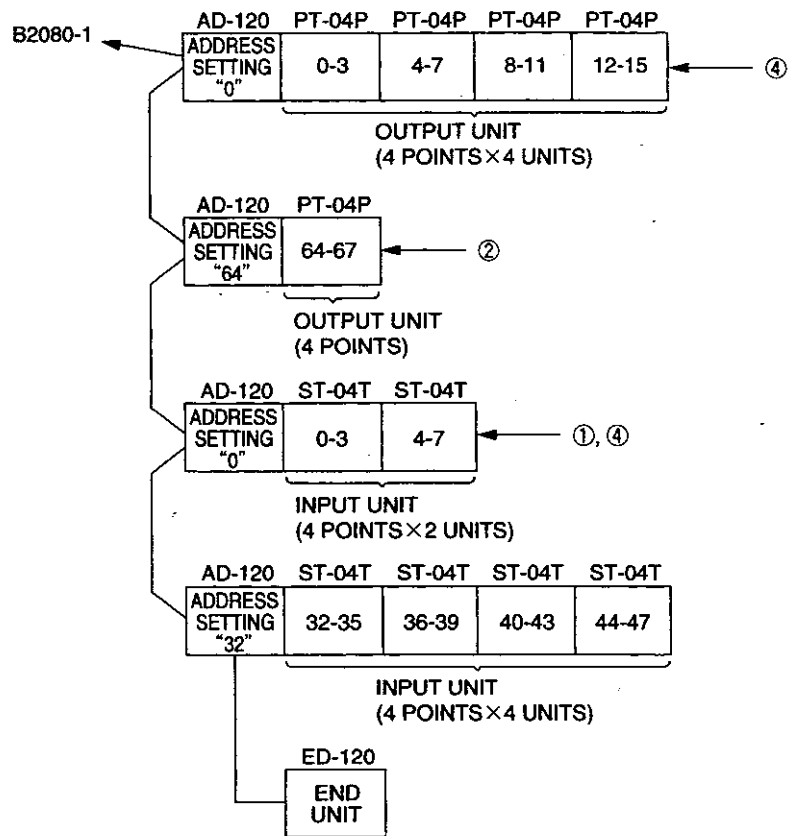

NOTE

For address setting, pay special attention to the following points.

- ① Do not install the UNI-WIRE system input unit on the address to which output is assigned by B2808-1 I/O point selector switches. (If both input and output are installed on the same address by mistake, both the input and output signal are output.)
- ② Do not install the UNI-WIRE system output unit on the address to which input is assigned by B2808-1 I/O point selector switches. (Installing it means inputting the OFF signal.)
- ③ If more than one input unit is installed with the same bit number, the signals are overlapped.
- ④ Do not install an input unit and output unit with the same bit number. Otherwise, the data cannot be input or output correctly. (In this case, inputting and outputting signal contents are the same as those of ① and ②.)
- ⑤ If more than one output unit is installed with the same bit number, the same signal is output.

4.4 B2808T USAGE

B2808T usage is basically the same as B2808-1, 2 usages. The following describes different items between them.

- (1) Each type of terminals and modules for use with the UNI-WIRE system are specified as M (transmission distance 500 m, 256 point for exclusive use). For further details, contact your Yaskawa Control representative.
- (2) Setting of I/O Point Selector Switches
Set I/O point selector switch according to UNI-WIRE output and input points.

Table 4.3 Functions of I/O Point Selector Switches

I/O Point Selector Switch	Number of Input Relays	Number of Input Register Sets	Number of Output Coils	Number of Output Register Sets
0	128	7	16	0
1	128	6	32	0
2	128	4	64	0
3	128	2	96	0
4	128	0	128	0
5	96	0	128	2
6	64	0	128	4
7	32	0	128	6
8 to E	0	0	128	8
*F	Test mode (Prohibited)			

NOTE *Do not use this switch since it is for test mode only.

- (3) Setting of Transmission Mode Selector Switches

Set the transmission mode selector switch according to CPU module models. When using the MEMOCON-SC GL60 series, set it to "0".

Table 4.4 Functions of Transmission Selector Switches

Transmission Mode Selector Switch	Transmission Specifications	Applicable CPU Modules
0	500 m	GL40S GL60S GL60H GL70H
1	(Disabled)	
2	(Disabled)	
3	(Disabled)	
4 to 7	500 m Same as "0" select	CP3300
8	500 m	
9	(Disabled)	
A	(Disabled)	
B	(Disabled)	
C to E	500 m Same as "8" select	
*F	Test mode (Prohibited)	

NOTE *Do not use this switch since it is for test mode only.

(4) I/O Allocation and Signal Processing on UNI-WIRE System

- (a) B2808T can send a maximum of 256 points for input or output. Input and output registers are used for the input relays and output coils exceeding 128 points.

Because the input relay signal and input register signal sequence (LSB and MSB) are in reverse order, be careful when using a ladder program to input a signal to the input register.

In the same way, because the output coil signal and output register signal sequence (LSB and MSB) are also in reverse order, be careful when converting the output coil to the output register.

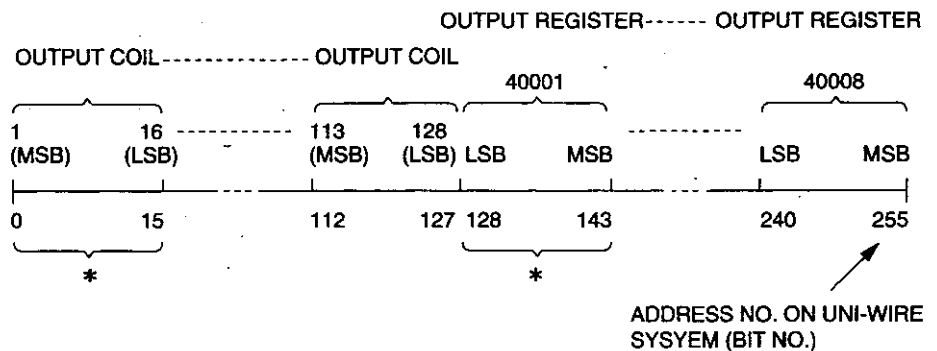

NOTE * The output coil signal sequence (LSB and MSB) and output register signal sequence (LSB and MSB) are in reverse order.

- (b) When using output coils 1 to 256 in UNI-WIRE system, output coils 129 to 256 are used for the output register. If a ladder program is not created, signal sequence (LSB and MSB) as shown in the above chart will be in reverse order. Typical ladder program corresponding output coils 1 to 256 to address 0 to 255 in UNI-WIRE system is shown below.

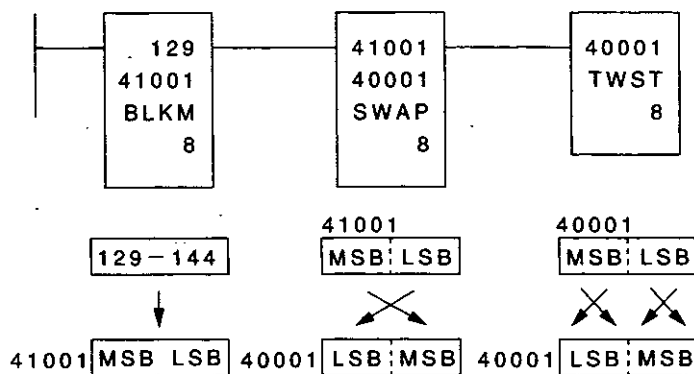

UNI-WIRE system handles addresses 0 to 127 without creating ladder program for output coils 1 to 128. After replacing output coils 129 to 256 in a holding register, bits are laid out in a row. Outputting output coils 129 to 256 after this procedure restores them to the same order as signal sequence (LSB and MSB) as output coils 1 to 128.

5 STATUS DISPLAY · TRANSMISSION DISTANCE

5.1 I/O STATUS DISPLAY SELECTION · TRANSMISSION DISTANCE SELECTION

According to Tables 5.1, 5.2 and 5.3, set the bit No. to be indicated in the I/O status indicators by using the LED status display selector switch.

Table 5.1 Status Display Selector Switch Functions (for B2808)

Setting of LED Status Display Selector Switch	I/O Status Indicators	Transmission Distance
0	Status of bit Nos. 0 to 31 are indicated in 1 to 32.	200 m
1	Status of bit Nos. 32 to 63 are indicated in 1 to 32.	
2	Status of bit Nos. 64 to 95 are indicated in 1 to 32.	
3	Status of bit Nos. 96 to 127 are indicated in 1 to 32.	
4	Status of bit Nos. 0 to 31 are indicated in 1 to 32.	500 m
5	Status of bit Nos. 32 to 63 are indicated in 1 to 32.	
6	Status of bit Nos. 64 to 95 are indicated in 1 to 32.	
7	Status of bit Nos. 96 to 127 are indicated in 1 to 32.	
8 ⋮ F	Do not use since these are in the test mode.	

NOTE

Read-in the transmission distance switching only when CPU supply is turned ON or module reset PB is depressed. Do not use selector switches "8 to F" since they are for test mode only.

Table 5.2 Status Display Selector Switch Functions (for B2808-1, -2)

Setting of LED Status Display Selector Switch	I/O Status Indicators
0	Status of bit Nos. 0 to 31 are indicated in 1 to 32.
1	Status of bit Nos. 32 to 63 are indicated in 1 to 32.
2	Status of bit Nos. 64 to 95 are indicated in 1 to 32.
3	Status of bit Nos. 96 to 127 are indicated in 1 to 32.
4	Status of bit Nos. 0 to 31 are indicated in 1 to 32.
5	Status of bit Nos. 32 to 63 are indicated in 1 to 32.
6	Status of bit Nos. 64 to 95 are indicated in 1 to 32.
7	Status of bit Nos. 96 to 127 are indicated in 1 to 32.
8 ⋮ F	Do not use since these are in the test mode.

NOTE Do not use selector switches "8 to F" since they are for test mode only.

Table 5.3 Status Display Selector Switch Functions (for B2808T)

Setting of LED Status Display Selector Switch	I/O Status Indicators
0	Status of bit Nos. 0 to 31 are indicated in 1 to 32.
1	Status of bit Nos. 32 to 63 are indicated in 1 to 32.
2	Status of bit Nos. 64 to 95 are indicated in 1 to 32.
3	Status of bit Nos. 96 to 127 are indicated in 1 to 32.
4	Status of bit Nos. 128 to 159 are indicated in 1 to 32.
5	Status of bit Nos. 160 to 191 are indicated in 1 to 32.
6	Status of bit Nos. 192 to 223 are indicated in 1 to 32.
7	Status of bit Nos. 224 to 255 are indicated in 1 to 32.
8 ⋮ F	Do not use since these are in the test mode.

NOTE Do not use selector switches "8 to F" since they are for test mode only.

5.2 LED DISPLAY AT FAULT OCCURRENCE

The fault error contents are indicated by LEDs of READY, SEND, ERR 1, 2 and 3.

Table 5.4 Error Display

●: Blinks, ○: Lights, ×: Extinguished

	LED Indicating Status					Starting Input Register Lower 4 Bits	Fault Contents	Corrective Action	Relay Contact	I/O Service on UNI-WIRE System	Input Data to PC
	READY	SEND	ERR1	ERR2	ERR3						
At Normal Operation	○	○	×	×	×	1111			Closed		
①	●	×	×	×	×	0000	Main CPU ROM/RAM fault diagnosis	Replace the module.	Open	"0" is output Transmission stops	OFF
②	×	○	×	○	×	0000	Main CPU watchdog timer fault	Replace the module.			
③	×	×	●	×	×	0000	Sub-CPU ROM fault diagnosis	Replace the module.			
④	×	×	×	●	×	0000	Sub-CPU RAM fault diagnosis	Replace the module.			
⑤	×	×	×	×	×	0000	Sub-CPU watchdog timer fault	Replace the module.			
⑥	○	○	×	×	×	(1111)	CPU RUN stop	Run the CPU by PP.	Closed		
⑦	×	○	×	×	×	0111	Main CPU communication error	Replace the module.	Open	"0" is output	OFF
⑧	○	○	×	×	●	0111	Sub-CPU communication error	Replace the module.			
⑨	○	○	○	×	×	1110	Shortcircuit between UNI-WIRE D and G	Recheck the wiring. Automatic recovery.			
⑩	○	○	○	×	○	1010	Shortcircuit between UNI-WIRE D and G. Reverse connection between D and G	Recheck the wiring. Automatic recovery.			
⑪	○	○	○	○	○	1010	Shortcircuit between UNI-WIRE D and G. Reverse connection between D and G.	Recheck the wiring. Automatic recovery.	Open	"0" is output	OFF
⑫	○	○	○	○	○	1011	Reverse connection between D and G.	Recheck the wiring. Automatic recovery.			

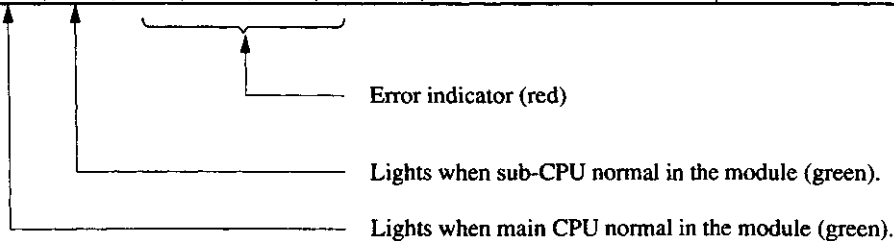

NOTE

- 1 The status information of the UNI-WIRE system can be monitored by the input register lower 4 bits. (See the NOTE in 4.2.)
- 2 In order to prevent improper output by communication error, build a safe circuit such as cutting the UNI-WIRE system output module power supply line by using B2808 relay contacts.

Table 5.4 Error Display (Cont'd)

●: Blinks, ○: Lights, ×: Extinguished

	LED Indicating Status					Starting Input Register Lower 4 Bits	Fault Contents	Corrective Action	Relay Contact	I/O Service on UNI-WIRE System	Input Data to PC
	READY	SEND	ERR1	ERR2	ERR3						
13	○	-○	×	○	×	1101	Shortcircuit between uni-wire D and 24 V. 24 VDC power not supplied.	Recheck the wiring. Automatic recovery. Recheck 24 VDC power supply.	Open	"0" is output	OFF
14	○	○	×	○	○	1011	Shortcircuit between UNI-WIRE D and G. Shortcircuit between UNI-WIRE D and 24 V. End unit fault. Reverse connection between D and G. D line disconnect.	Recheck the wiring. Automatic recovery.			
15	○	○	×	○	○	1001	Shortcircuit between UNI-WIRE D and 24 V 24 VDC power not supplied	Recheck the wiring. Automatic recovery. Recheck 24 VDC power supply.			
16	○	○	×	×	○	1011	Shortcircuit between UNI-WIRE D and G. Shortcircuit between UNI-wire D and 24 V. End unit fault. Reverse connection between D and G. D line disconnect.	Recheck the wiring Automatic recovery.			

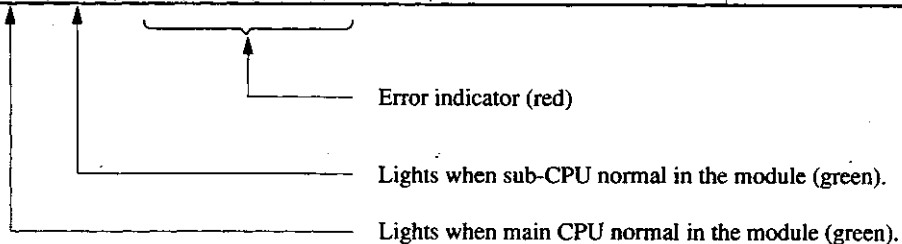

NOTE

- 1 The status information of the UNI-WIRE system can be monitored by the input register lower 4 bits. (See the NOTE in 4.2.)
- 2 In order to prevent improper output by communication error, build a safe circuit such as cutting the UNI-WIRE system output module power supply line by using B2808 relay contacts.

6 TYPICAL CONNECTIONS (B2808-1)

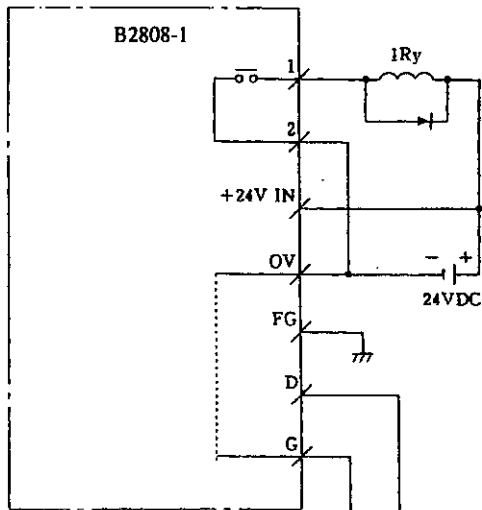

Precautions on handling

1. Use a 24 VDC regulated power supply (22.8 to 26.4 VDC) with UNI-WIRE system devices.
2. Separate communication and I/O cables from high voltage or power lines as much as possible in order to protect the system from electrical interference.
3. +24 V-0 V is used for power supply and D-G is used for the serial communication between devices. Use one cabtyre cable per UNI-WIRE system. Do not combine several systems on one multi-conductor cable. Communications errors may occur due to cross talk.
4. The total distance between units is up to 200 m. When the load capacity (consumed power) of sensors, lamps and coils connected to the UNI-WIRE system modules becomes too large, voltage drop of the power supply line (+24 V-0 V) can become large enough to cause the sensors, coils and modules to malfunction. In this case, provide power at the modules and connect between the modules with only 2 conductor cable for D and G. The total distance from the module to last UNI-WIRE system module may be up to 200 m with a maximum number of 20 connected units (AD-120). 2 conductor cable of 0.5 mm² or more should be used.

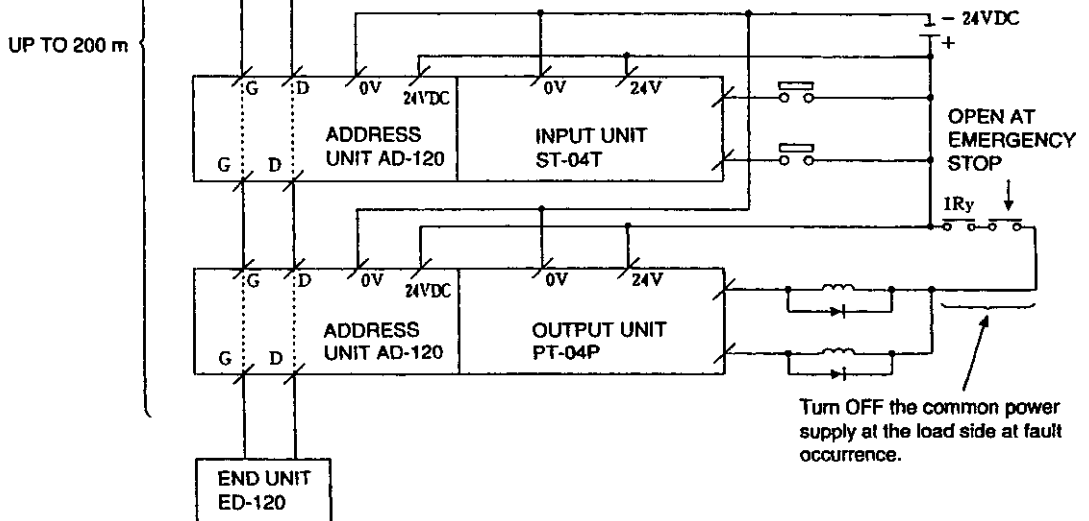

NOTE

When transmission distance is 500 m (B2808-2), a 500 m compatible UNI-WIRE system must also be used.

7 TYPICAL SYSTEM CONFIGURATION

The following describes the typical system configuration using UNI-WIRE Interface Module B2808-1.

(1) Communication Contents

Use the UNI-WIRE Interface Module B2808-1 to perform the following communications.

- Digital output: 32 points
- Register (numerical value) output: 2 sets
- Digital input: 32 points
- Register (numerical value) input: 2 sets

(2) Allocation to CPU Module

Reference number allocated to CPU module is as follows:

- Digital output: 00001 32 points
- Register (numerical value) output: 40001 2 sets
- Digital input: 10001 32 points
- Register (numerical value) input: 30001 3 sets

NOTE

Add 1-set to register input set numbers for UNI-WIRE system. UNI-WIRE system status information is stored in the leading register.

(3) Allocation to B2808-1

Selector switch settings for UNI-WIRE Interface Module B2808-1 I/O points are shown below.

- Output point selector switch setting: D (digital 32 points, register 2 sets)
- Input point selector switch setting: D (digital 32 points, register 2 sets)

(4) UNI-WIRE System Settings

Typical UNI-WIRE system setting is shown in Fig. 7.1.

(5) UNI-WIRE System Configuration

Typical UNI-WIRE system configuration model as described above is shown in Fig. 7.2.

M-SC GL60 SERIES (APPLICABLE REMOTE I/O SECTION)

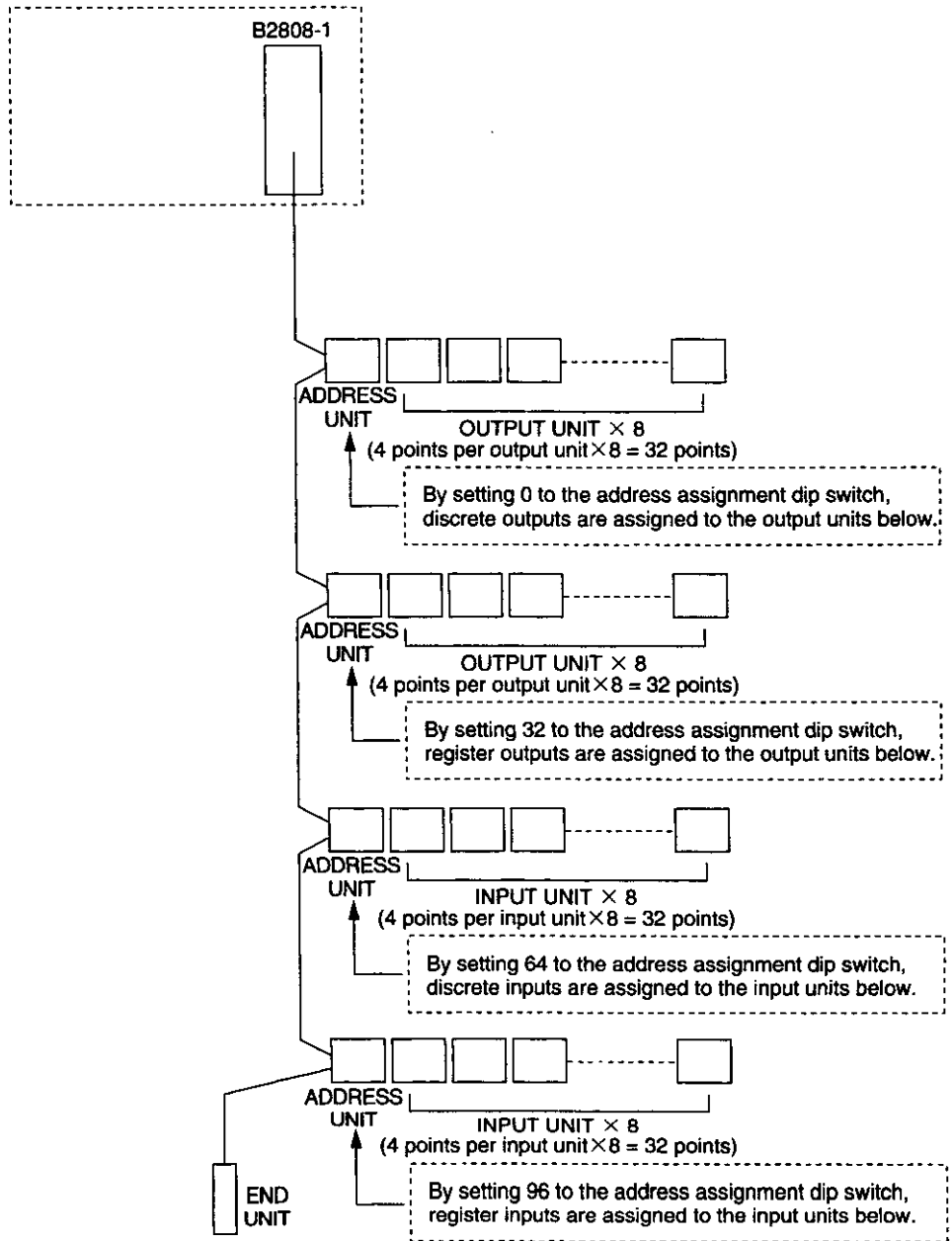

Fig. 7.1 Typical UNI-WIRE System Setting

M-SC GL60 SERIES (APPLICABLE REMOTE I/O SECTION)

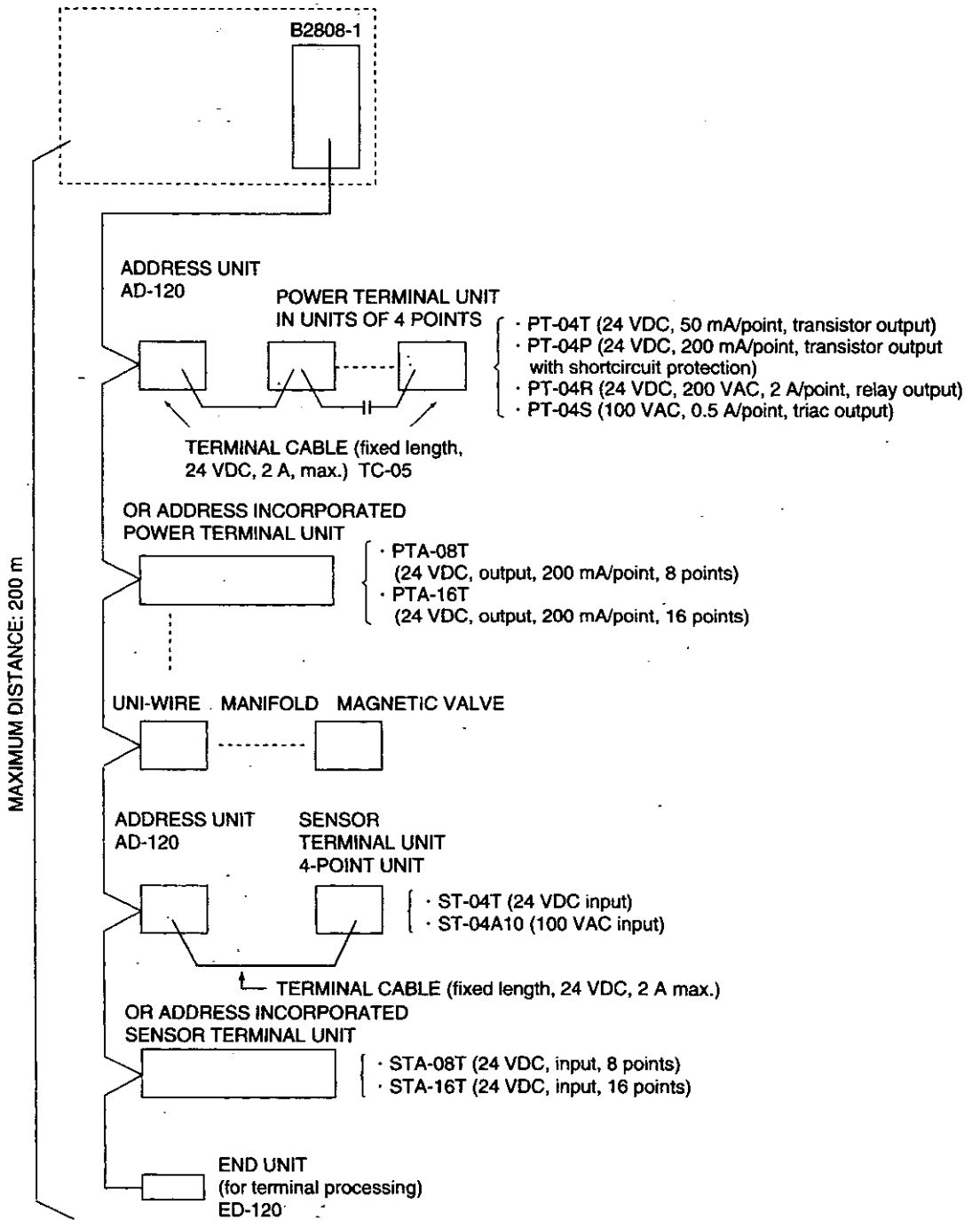

Fig. 7.2 Typical UNI-WIRE System Configuration

(6) Cautions for UNI-WIRE System Configuration

Observe the following cautions when using the UNI-WIRE Interface Module B2808-1 for UNI-WIRE system construction.

- ① Distance between units when using the B2808-01 should be 200 m.
- ② When the load capacity (consumed power) of sensors, coils and lamps connected with I/O units becomes too large, voltage drop of the power supply line (+24 V-0 V) will become large enough to cause malfunction of the UNI-WIRE system. In this case, provide power (22.8 to 26.4 VDC) at the modules.
- ③ Even when not using the input register, enter 1 input register set to the CPU module. UNI-WIRE system status information is stored in the head input register.

NOTE

When transmitting distance is 500 m, the following construction equipment must be used.

UNI-WIRE Interface Module: JAMSC-B2808-2, JAMSC-B2808T

UNI-WIRE System Configuration Equipment:

500 m compatible UNI-WIRE System Configuration Equipment

8 DIMENSIONS in mm (inches)

(1) JAMSC-B2808, -1, -2

When using B2808-1, "B2808-1" is marked.
When using B2808-2, "B2808-2" is marked.

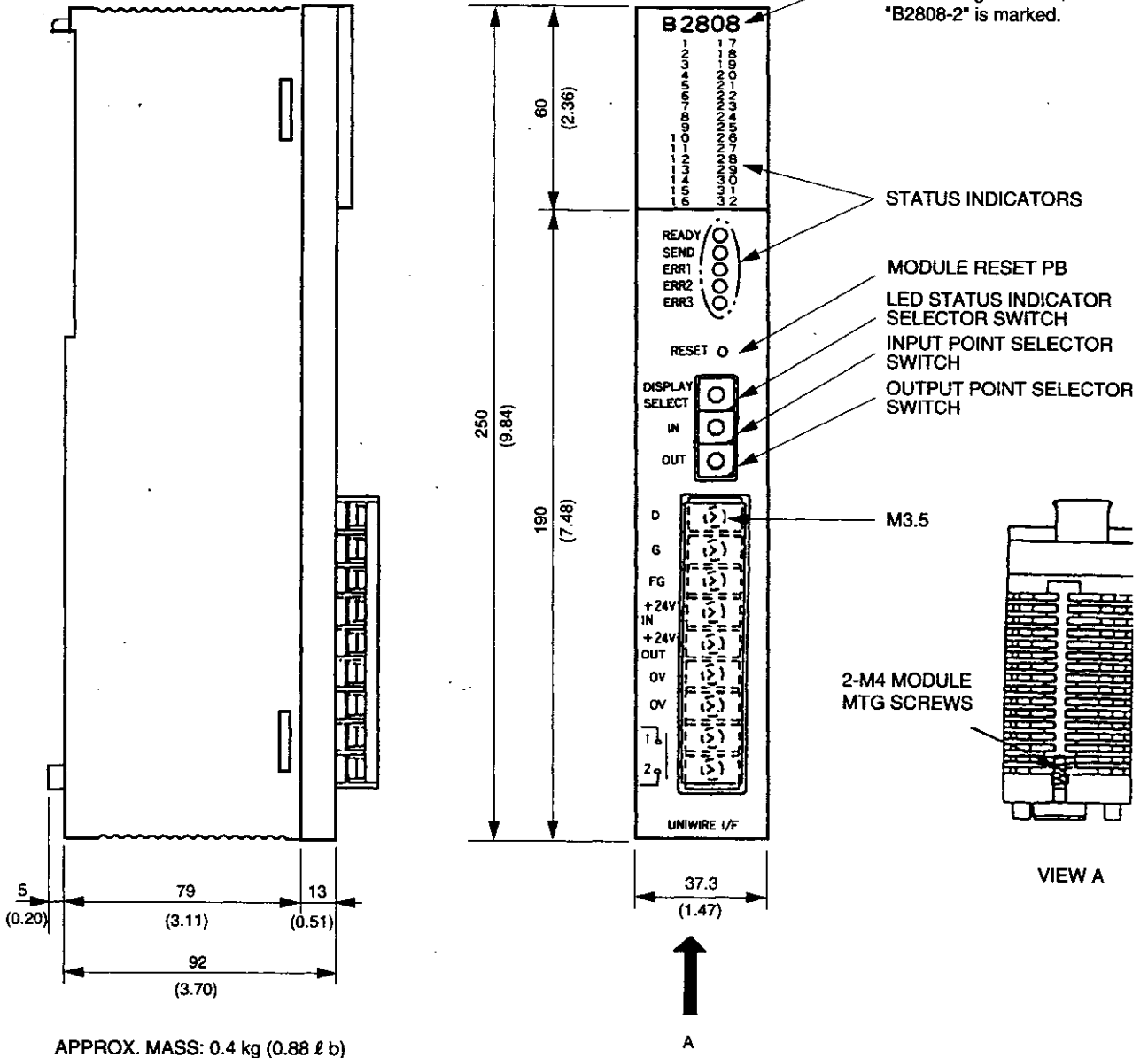

(2) JAMSC-B2808T

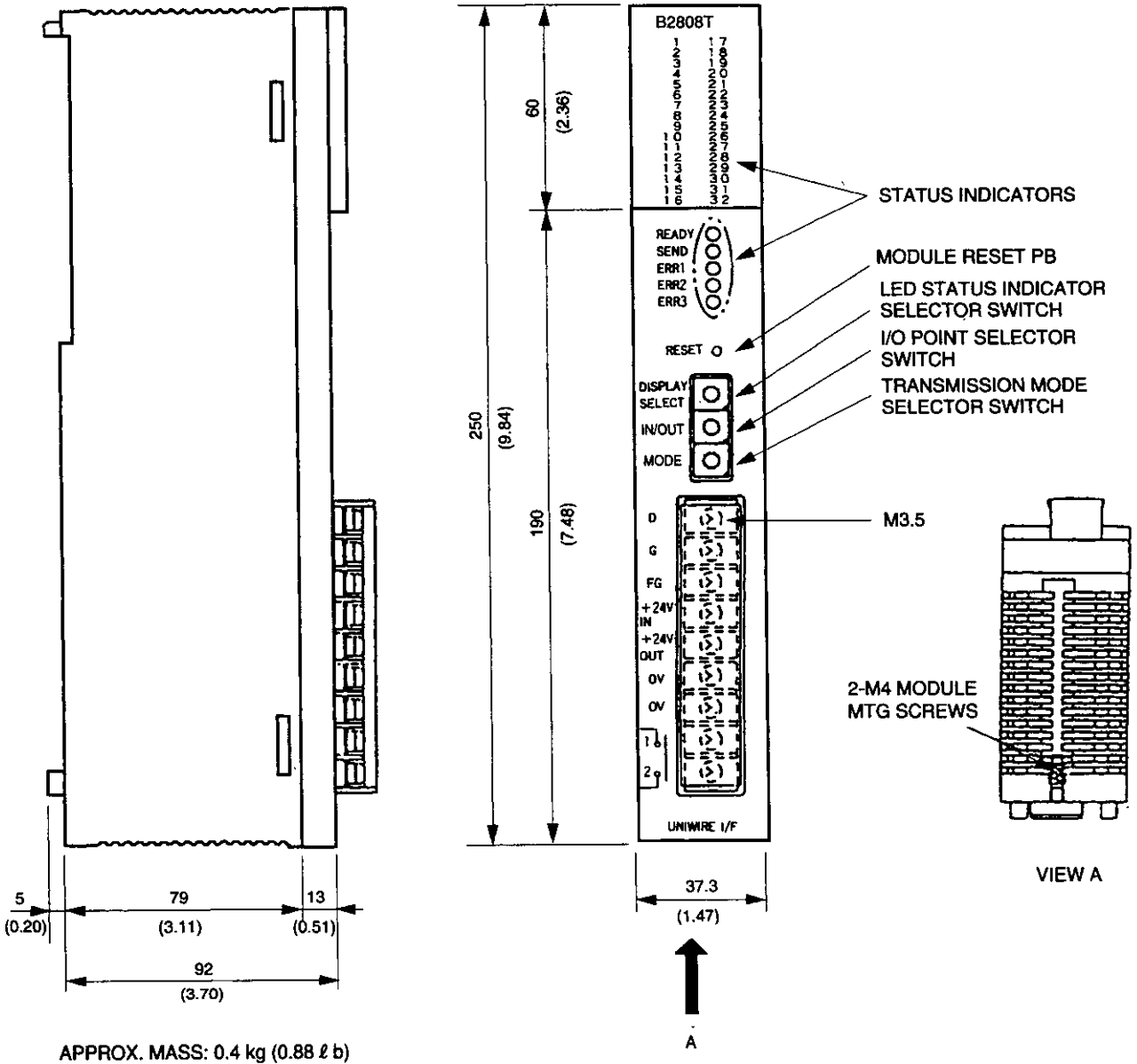

UNI-WIRE INTERFACE MODULE DESCRIPTIVE INFORMATION

TOKYO OFFICE

New Pier Takeshiba South Tower, 1-16-1, Kaigan, Minatoku, Tokyo 105-6891 Japan
Phone 81-3-5402-4511 Fax 81-3-5402-4580

YASKAWA ELECTRIC AMERICA, INC.

2121 Norman Drive South, Waukegan, IL 60085, U.S.A.
Phone 1-847-887-7000 Fax 1-847-887-7370

MOTOMAN INC. HEADQUARTERS

805 Liberty Lane West Carrollton, OH 45449, U.S.A.
Phone 1-937-847-6200 Fax 1-937-847-6277

YASKAWA ELÉTRICO DO BRASIL COMÉRCIO LTDA.

Avenida Fagundes Filho, 620 Bairro Saude-Sao Paulo-SP, Brazil CEP: 04304-000
Phone 55-11-5071-2552 Fax 55-11-5581-8795

YASKAWA ELECTRIC EUROPE GmbH

Am Kronberger Hang 2, 65824 Schwalbach, Germany
Phone 49-6196-569-300 Fax 49-6196-888-301

Motoman Robotics Europe AB

Box 504 S38525 Torsås, Sweden
Phone 46-486-48800 Fax 46-486-41410

Motoman Robotec GmbH

Kammerfeldstraße 1, 85391 Altershausen, Germany
Phone 49-8166-900 Fax 49-8166-9039

YASKAWA ELECTRIC UK LTD.

1 Hunt Hill Orchardton Woods Cumbernauld, G68 9LF, United Kingdom
Phone 44-1236-735000 Fax 44-1236-458182

YASKAWA ELECTRIC KOREA CORPORATION

Ktpa Bldg #1201, 35-4 Youido-dong, Yeongdungpo-Ku, Seoul 150-010, Korea
Phone 82-2-784-7844 Fax 82-2-784-8495

YASKAWA ELECTRIC (SINGAPORE) PTE. LTD.

151 Lorong Chuan, #04-01, New Tech Park Singapore 556741, Singapore
Phone 65-282-3003 Fax 65-289-3003

YASKAWA ELECTRIC (SHANGHAI) CO., LTD.

4F No.18 Aona Road, Waigaoqiao Free Trade Zone, Pudong New Area, Shanghai 200131, China
Phone 86-21-5866-3470 Fax 86-21-5866-3889

YATEC ENGINEERING CORPORATION

Shen Hsiang Tang Sung Chiang Building 10F 146 Sung Chiang Road, Taipei, Taiwan
Phone 886-2-2563-0010 Fax 886-2-2567-4677

YASKAWA ELECTRIC (HK) COMPANY LIMITED

Rm. 2909-10, Hong Kong Plaza, 186-191 Connaught Road West, Hong Kong
Phone 852-2803-2385 Fax 852-2547-5773

BEIJING OFFICE

Room No. 301 Office Building of Beijing International Club, 21
Jianguomenwai Avenue, Beijing 100020, China
Phone 86-10-6532-1850 Fax 86-10-6532-1851

TAIPEI OFFICE

Shen Hsiang Tang Sung Chiang Building 10F 146 Sung Chiang Road, Taipei, Taiwan
Phone 886-2-2563-0010 Fax 886-2-2567-4677

SHANGHAI YASKAWA-TONGJI M & E CO., LTD.

27 Hui He Road Shanghai China 200437
Phone 86-21-6531-4242 Fax 86-21-6553-6060

BEIJING YASKAWA BEIKE AUTOMATION ENGINEERING CO., LTD.

30 Xue Yuan Road, Haidian, Beijing P.R. China Post Code: 100083
Phone 86-10-6233-2782 Fax 86-10-6232-1536

SHOUGANG MOTOMAN ROBOT CO., LTD.

7, Yongchang-North Street, Beijing Economic Technological Investment & Development Area,
Beijing 100076, P.R. China
Phone 86-10-6788-0551 Fax 86-10-6788-2878



YASKAWA ELECTRIC CORPORATION