

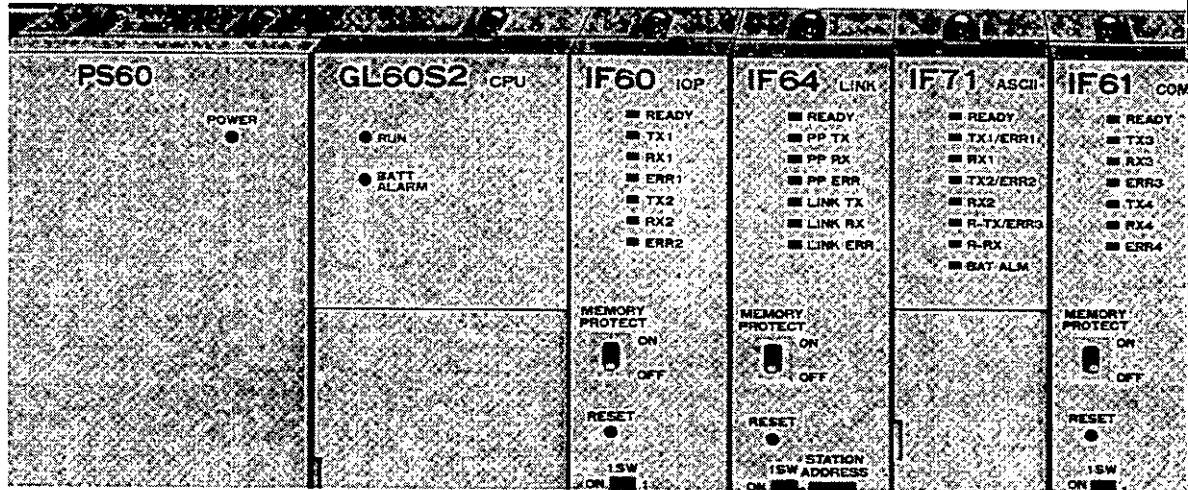

PC LINK MODULE USER'S MANUAL

PROGRAMMABLE CONTROLLER: MEMOCON-SC GL60S
TYPE JAMSC-IF64



NOTES FOR SAFE OPERATION

Read these manuals thoroughly before use of MEMOCON-SC GL60S. In these manuals, NOTES FOR SAFE OPERATION are classified as "WARNING" and "CAUTION."

 **WARNING** : Indicates a potentially hazardous situation which, if not avoided, could result in death or serious injury to personnel.

 **CAUTION** : Indicates a potentially hazardous situation which, if not avoided, may result in minor or moderate injury to personnel and damage to equipment. It may also be used to alert against unsafe practices.

Even items described in  **CAUTION** may result in a vital accident in some situations. In either case, follow these important notes.

The following shows the symbols of prohibition and mandatory action.

 **PROHIBITION** : Specifies prohibited handling.

 **MANDATORY ACTION** : Specifies actions that must be taken.

After reading these manuals, keep them readily available for those using the equipment.

1 INSTALLATION



CAUTION

- The installation environment must meet the environmental conditions given in the product catalog and manuals.

Using the MEMOCON-SC in environments subject to high temperatures, high humidity, excessive dust, corrosive gases, vibration, or shock can lead to electric shock, fire, or faulty operation.

Do not use the MEMOCON-SC in the following locations.

- Locations subject to direct sunlight or ambient temperatures not between 0 and 55°C.
- Locations subject to relative humidity in excess of 95%, rapid changes in humidity, or condensation.
- Locations subject to corrosive or flammable gas.
- Locations that would subject the MEMOCON-SC to direct vibration or shock.
- Locations subject to contact with water, oil, chemicals, etc.

- Do not remove the cover of the connector where a module is not mounted. Foreign matter can cause malfunction.

- Be sure all screws are tight.

All screws for installation and terminal board should be securely tightened and checked for loosening.

Malfunctions in the MEMOCON-SC may occur as a result of loose screws.

2 WIRING



CAUTION

- Wiring must be performed by qualified personnel. Mistakes in wiring can cause fires, product failure, or malfunctions.
- When wiring, do not allow foreign matter such as wire chips to enter the mounting base or the module. Foreign matter can cause fires, product failures, or malfunctions.
- Ground the shielded tape of the coaxial cable for the PC Link module to one point (a resistance of 100 Ω max).



MANDATORY ACTION

- Ground the protective ground terminal to a resistance of 100 Ω max. Failure to observe this instruction may result in electric shock or malfunction.

SEPARATE THE INTERFACE CABLES FROM OTHER CABLES

- Interface cables connecting to PC Link Module must be separated from other control cables. Failure to observe this instruction may result in malfunctions.

3 PRECAUTION UPON USE



CAUTION

- Operations such as RUN, STOP, forced outputs, and program changes during operation must be carried out with care. Operational errors may damage the machine or cause accidents.

4 MAINTENANCE



PROHIBITION

- Do not attempt to disassemble or modify the MEMOCON-SC in any way. Doing so can cause fires, product failure, or malfunctions.

5 GENERAL PRECAUTION

- MEMOCON-SC was not designed or manufactured for use in devices or systems that concern peoples' lives.

Users who intend to use the product described in this manual for special purposes such as devices or systems relating to transportation, medical, space aviation, atomic power control, or underwater use must contact YASKAWA representatives beforehand.

- This product has been manufactured under strict quality control guidelines. However, if this product is to be installed in any location in which a failure of MEMOCON-SC involves a life and death situation or in a facility where failure may cause a serious accident, safety devices must be installed to minimize the likelihood of any accident.
- Any illustrations, photographs, or example used in this manual are provided as examples only and may not apply to all product to which this manual is applicable.
- The products and specifications described in this manual or the content and presentation of the manual may be changed without notice to improve the product and/or the manual.
A new version of the manual will be re-released under a revised document number when any changes are made.
- Contact your YASKAWA representative listed on the back of this manual to order a new manual whenever this manual is damaged or lost.
Please provide the document number listed on the front cover of this manual when ordering.
- Contact your YASKAWA representative listed on the back of this manual to order new nameplates whenever a nameplate becomes worn or damaged.
- YASKAWA cannot make any guarantee for products which have been modified.
YASKAWA assumes no responsibility for any injury or damage caused by a modified product.

OVERVIEW OF MANUAL

- This manual describes specifications, handling, transmission procedure, etc. of the PC Link module.
- Read this manual carefully in order to use the MEMOCON-SC properly. Also, keep this manual in a safe place so that it can be used whenever necessary.
- Refer to the following manuals as necessary.

	Manual	Manual Number	Contents
CPU Module	MEMOCON-SC GL60S DESCRIPTIVE INFORMATION	SIE-C815-14.1	Describes system configuration devices and their functions, specifications, application methods, etc., for the MEMOCON-SC GL60S.
	MEMOCON-SC GL40S DESCRIPTIVE INFORMATION	SIE-C815-15.1	Describes system configuration devices and their functions, specifications, application methods, etc., for the MEMOCON-SC GL40S.
	MEMOCON-SC GL60H/GL70H DESCRIPTIVE INFORMATION	SIE-C815-17.1	Describes system configuration devices and their functions, specifications, application methods, etc., for the MEMOCON-SC GL60H/GL70H.
Man/ Machine Interface	MEMOCON-SC GL60S P150 PROGRAMMING PANEL DESCRIPTIVE INFORMATION	SIE-C815-14.2	Describes the function, specifications, application methods, etc., for the P150 Programming Panel.
	MEMOCON-SC GL60S P150 PROGRAMMING PANEL DESCRIPTIVE INFORMATION	SIE-C815-14.3	Describes the SFC function, specifications, application methods, etc., for the P150 Programming Panel

- Thoroughly check the specification and conditions of the product before use.

USING THIS MANUAL

This Manual is compiled for readers who already have a basic knowledge of the Yaskawa MEMOCON products. We strongly recommend you read the User's Manual for MEMOCON-SC GL40S, GL60S, GL60H, GL70H before you start reading this manual.

- **Meaning of Basic Terms**

In this manual, the following terms indicate the meanings as described below, unless otherwise specified.

- IF64 = PC Link Module
- PC = Programmable Controller
- PP = Programming Panel
- GL40S, GL60S, GL60H, GL70H = MEMOCON-SC GL40S, GL60S, GL60H, GL70H Programmable Controllers

CONTENTS

1. FEATURES AND SYSTEM CONFIGURATION	1
1.1 FEATURES	1
1.2 SYSTEM CONFIGURATION	2
2. SPECIFICATIONS	4
2.1 GENERAL SPECIFICATIONS	4
2.2 MODULE SPECIFICATIONS	4
2.3 TRANSMISSION SPECIFICATIONS	5
2.4 FUNCTIONS	9
3. INDICATIONS AND SWITCH SETTINGS	10
3.1 INDICATIONS	10
3.2 SWITCH SETTINGS	11
4. INTER-PC LINK FUNCTION	14
4.1 TRANSMISSION/RECEPTION OF LINK DATA	14
4.2 ALLOCATION AND ITS OPERATION	15
5. LINK FUNCTION WITH HOST COMPUTER BY PP PORT	34
5.1 MONITORING LINK DATA	34
5.2 CONNECTION OF PROGRAMMING PANEL	35
6. TRANSMISSION TIME	36
6.1 TRANSMISSION TIME FOR LINK BETWEEN PCs	36
6.2 TRANSMISSION TIME FROM PP PORT	39
7. MOUNTING	45
7.1 ENVIRONMENTAL CONDITIONS	45
7.2 WIRING	45
8. INITIALIZING SYSTEM	48
9. TRANSMISSION CONTROL PROCEDURE	48
9.1 TOKEN PASS	48
9.2 ERROR PROCESSING	49
9.3 SCAN AND TRANSMISSION OF LINK DATA	52
10. MAINTENANCE	53
APPENDIX A DIMENSIONS in mm (inches)	54
APPENDIX B MEMOBUS COMMAND LIST	55

INDEX

Subject	Chapter	Section No.	Page
A Allocation	4	4.2.1	15
ALLOCATION AND ITS OPERATION	4	4.2	15
C Coaxial Cable Connector	2	2.3.4	7
Coaxial Cable Specifications	2	2.3.3	6
Connection	7	7.2.1	45
CONNECTION OF PROGRAMMING PANEL	5	5.2	35
D DIMENSIONS in mm (inches)	APPENDIX	A	54
E ERROR PROCESSING	9	9.2	49
F FEATURES	1	1.1	1
FUNCTIONS	2	2.4	9
G GENERAL SPECIFICATIONS	2	2.1	4
I INDICATIONS	3	3.1	10
INDICATIONS AND SWITCH SETTINGS	3		10
Influence of Message Transmission	6	6.2.3	44
INITIALIZING SYSTEM	8		48
INTER-PC LINK FUNCTION	4		14
L LINK FUNCTION WITH HOST COMPUTER BY PP PORT	5		34
Link Port Specifications	2	2.3.1	5
M MAINTENANCE	10		53
MEMOBUS Cable Specifications	2	2.3.5	8
MEMOBUS COMMAND LIST	APPENDIX	B	55
Memory Protect	3	3.2.1	11
MODULE SPECIFICATIONS	2	2.2	4
MONITORING LINK DATA	5	5.1	34
MOUNTING	7		45
N Notes on Changing the Allocation	4	4.2.3	33
O Operation for Allocation	4	4.2.2	16
Other Settings	3	3.2.4	13
P PP Port Specifications	2	2.3.2	5
R Required Transmission Time	6	6.2.2	41
S SCAN AND TRANSMISSION OF LINK DATA	9	9.3	52
Setting Transmission Rate	3	3.2.3	13
SPECIFICATIONS	2		4
Station Address	3	3.2.2	12
SWITCH SETTINGS	3	3.2	11
SYSTEM CONFIGURATION	1	1.2	2
T TOKEN PASS	9	9.1	48
TRANSMISSION CONTROL PROCEDURE	9		48
Transmission Delay	6	6.1.1	36
Transmission Delay	6	6.2.1	39
TRANSMISSION SPECIFICATIONS	2	2.3	5
TRANSMISSION TIME	6		36
Transmission Time	6	6.1.2	37
Transmission Time	6	6.2.2	41
TRANSMISSION TIME FOR LINK BETWEEN PCs	6	6.1	36
TRANSMISSION TIME FROM PP PORT	6	6.2	39
TRANSMISSION/RECEPTION OF LINK DATA	4	4.1	14
W WIRING	7	7.2	45

1. FEATURES AND SYSTEM CONFIGURATION

1.1 FEATURES

Mutual data exchange between GL60S's can be performed at high speed, by using the IF64. A special reference for the link is prepared, and there is no need for any communication program.

- High-speed LAN

Coaxial cable is used for the transmission line, to allow N : N communication by token passing bus method. Communication can be accomplished with the GL60S, as well as with the CP series, including the master controller CP-3300 and the system controller CP-3500.

- High-speed, Long-distance Communication

Transmission of maximum 1 km in 4 Mbps transmission speed is enabled by selecting the coaxial cable.

- No Communication Program Required

The special reference for the link eliminates the necessity for a communication program in the GL60S.

- MEMOBUS Port

The one MEMOBUS port is offered to permit programming and monitoring of up to 32 GL60S's with no modem. These operations are available by connecting a programming panel to this port. The port also accepts ACGC, computer, etc.

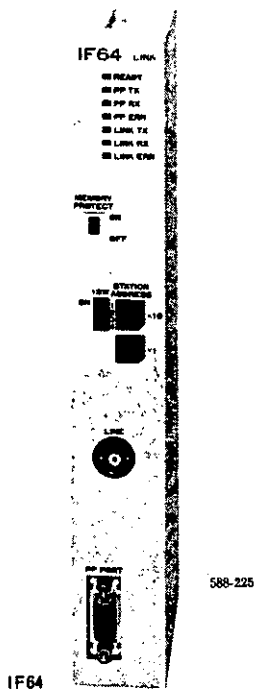

1.2 SYSTEM CONFIGURATION

Examples of PC link system configuration are shown below:

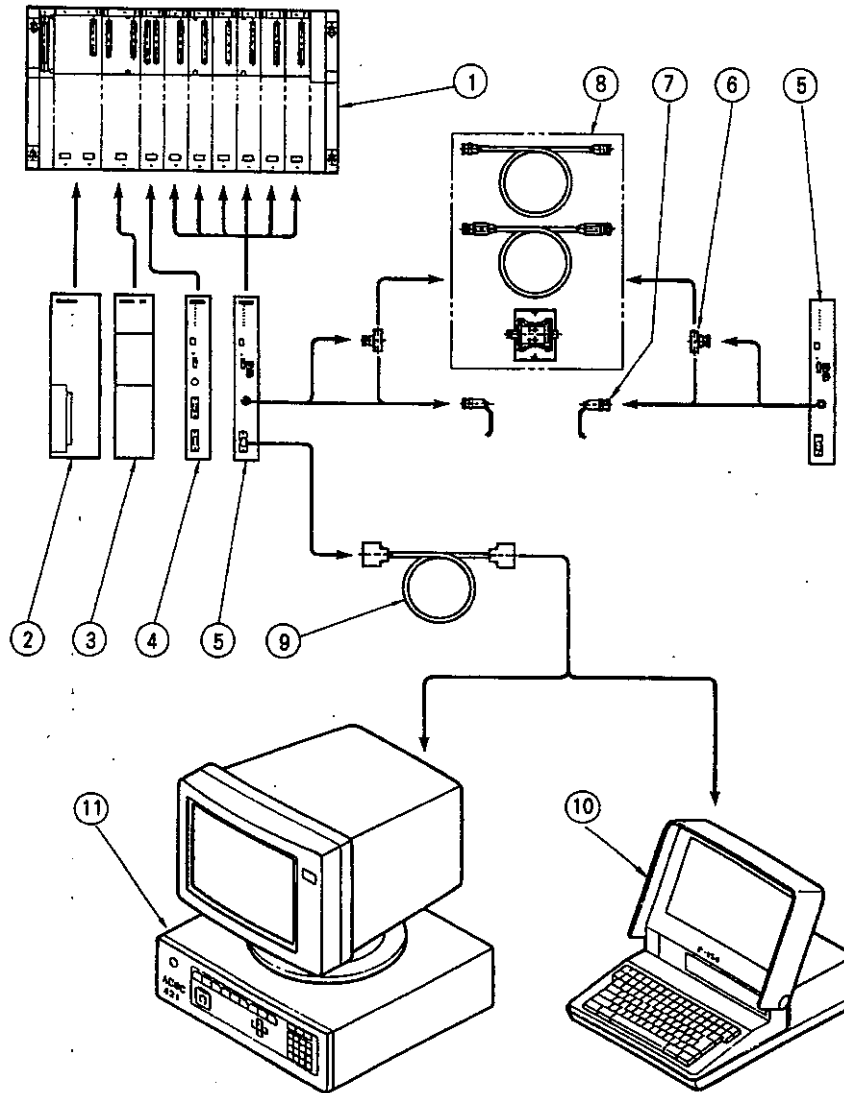

No.	Name	Type	Remarks
1	CPU Base	JRMSI-MB60	
2	Power Supply Module	JRMSP-PS60	
3	CPU Module	DDSCR-GL60S2	
4	IOP Module	JZMSC-IF60	
5	PC LINK Module	JAMSC-IF64	Only one module
6	T-type Connector	BNC-TA-JPJ-Ni-CAu	
7	Terminator	BNC-RC-75Ω-Ni-CAu	
8	Coaxial Cable Conversion Connector	JZMSZ-W60 JZMSZ-W61 T-0298	Select and use in accordance with user applications.
9	RS-232C Cable	JZMSZ-W1015	
10	Programming Panel	DISCT-P150	
11	FA Monitor	ACGC 411 ACGC 421	

Fig. 1.1 System Configuration (1)

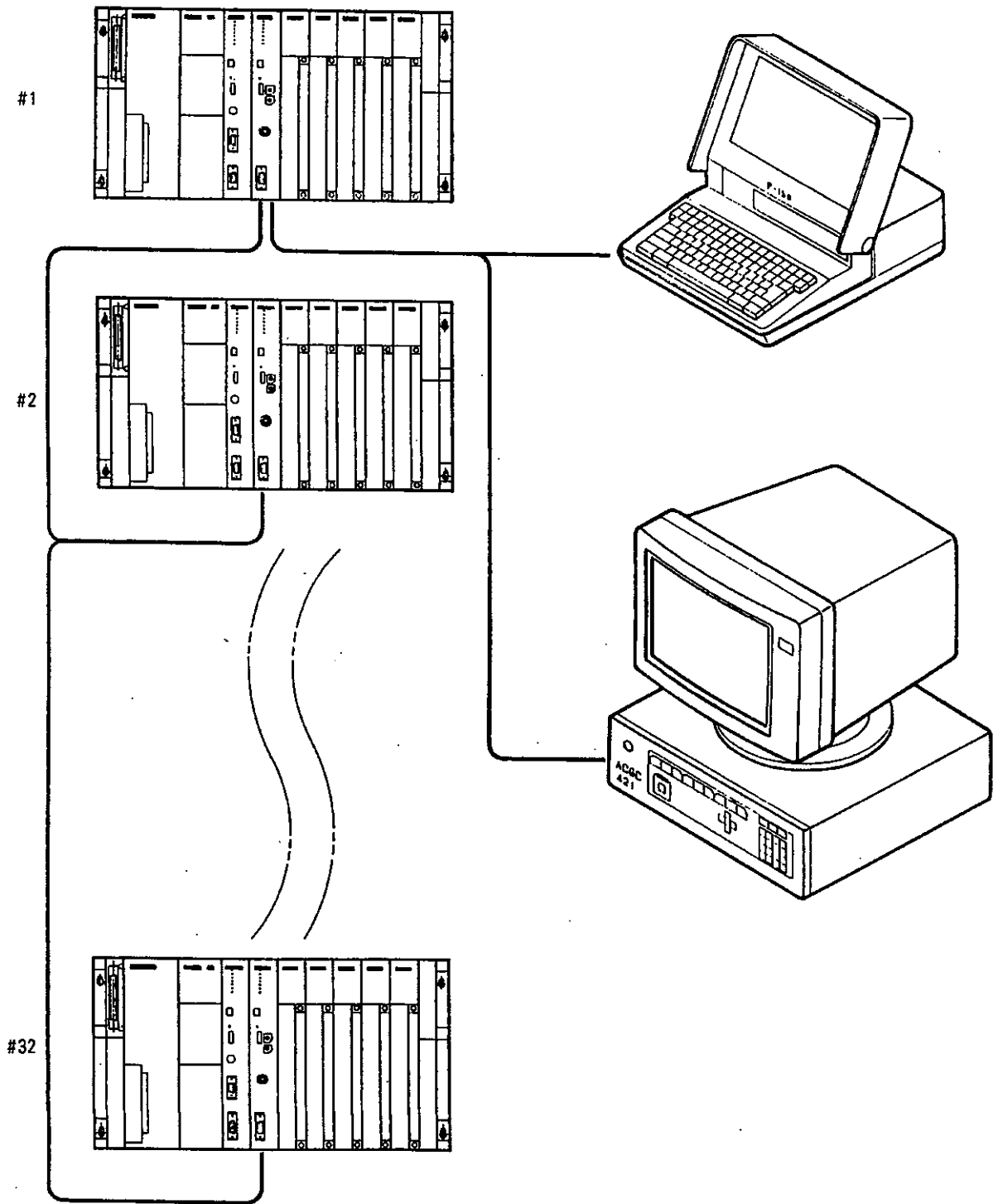

Fig. 1.2 System Configuraiton (2)

2. SPECIFICATIONS

2.1 GENERAL SPECIFICATIONS

Table 2.1 shows general specifications for IF64.

Table 2.1 General Specifications

Items	Specifications				
Ambient Temperature	0 to + 55°C				
Storage Temperature	- 20 to + 85°C				
Humidity	30 to 95% relative (Non-condensing)				
Vibration-Resistance	In compliance with JIS* C0911	Frequency	Acceleration	Amplitude	No. of Sweep
		10. to 55 Hz	—	0.075 mm	10 (1 octave/min.)
Shock-Resistance	In compliance with JIS* C0912 (10 G, each 3-time in 3 directions)				
Atmosphere	Free from inflammable, corrosive gases or dust				
Noise Immunity	1500 Vp-p, pulse width: 1 μ s, rising time: 1 ns (Noise applied to AC power side by noise simulator.)				
Cooling Method	Natural air-cooled				

* Japanese Industrial Standard

2.2 MODULE SPECIFICATIONS

Table 2.2 shows IF64 module specifications.

Table 2.2 Module Specifications

Items	Specifications
Type	JAMSC-IF64
Function	To communicate between PCs using special reference.
Indicators	READY: Lights at normal module. PP TX: Lights while data sent from PP port. PP RX: Lights while data received to PP port. PP ERR: Lights at PP port communication error. LINK TX: Lights while data sent from link port. LINK RX: Lights while data received to link port. LINK ERR: Lights at link port communication error.
Switches	<ul style="list-style-type: none"> • Memory protect • Reset • Station address • Transmission speed setting
Consumed Current	5 VDC: 1.3 A
Mounting Base	MB60 mounting base (CPU base)
Dimensions in mm (inch)	37.5 (1.48) W \times 250 (9.84) H \times 94 (3.70) D
Approx. Weight	0.6 kg 1.3 lb

2.3 TRANSMISSION SPECIFICATIONS

2.3.1 Link Port Specifications

Table 2.3 shows link port specifications of IF64.

Table 2.3 Link Port Specifications

Items	Specifications
Topology	Bus (Party line)
Media Access Control Method	Token passing bus (n:n communication)
Transmission Medium	Coaxial cable (75 Ω)
Transmission Method	Baseband (Manchester coding)
Data Transmission Rate	500 Kbps/1 Mbps/2 Mbps/4 Mbps (Selected by DIP switch.) Selectable in accordance with transmission distance.
Max. Cable Length*	1 km (Depends on data baud rate and cable to be used.)
RAS	<ul style="list-style-type: none"> • Failure station: Automatically disconnected from the line. • Recovered station: Automatically connected to the line.
Synchronous	Frame synchronous
Frame Format	HDLC
Insulation	Pulse transformer
No. of Stations	Up to 32 stations
Station Address	1 to 32 (Set by rotary switch.)
Connector	BNC connector

* For more information, refer to "GL60S Remote I/O User's Manual" (SIE-C815-14.7).

2.3.2 PP Port Specifications

Table 2.4 shows PP port specifications of IF64.

Table 2.4 PP Port Specifications

Items	Specifications
Standard	In compliance with EIA RS-232C
Synchronous	Half duplex, asynchronous
Baud Rate	9600 bps
Data Bits	8 bits
Stop Bits	1 bit
Parity Check	Even
Protocol	MEMOBUS protocol
Station Address	1 to 32 Same as station address of link port.
Connector	Mini D-SUB 9-pin connector

2.3.3 Coaxial Cable Specifications

The coaxial cable to be used is similar to the cable for the GL60S remote I/O system. Refer to the SIE-C815-14.7 Memocon-SC GL60S remote I/O System User's Manual. Table 2.5 is a list of standard coaxial cables.

Table 2.5 List of Standard Coaxial Cables

Type JZMSZ-	Cable Length in m (inch)	Cable Type to be Used	Connector
W60-1	2 (78.74)	3C-2V For in-panel	BNC connectors at both ends
W60-2	3 (118.11)		
W60-3	5 (196.85)		
W61-1	2 (78.74)	5C-FB For panel-to-panel	F-Type connectors (F-5FB) at both ends
W61-2	5 (196.85)		
W61-3	10 (393.7)		
W453-001	2 (78.74)	5C-FL For panel-to-panel	F-Type connector (FSPW-5PEF) at both ends
W453-002	5 (196.85)		
W453-003	10 (393.7)		

Table 2.6 shows coaxial cable specifications.

Table 2.6 Coaxial Cable Specifications

Type (Fujikura Ltd.)	Shielded for Static Electricity and Magnet	Application	Conditions	Signal Attenuation: Pas (dB/km)			
				0.5 MHz	1 MHz	2 MHz	4 MHz
3C-2V 3C-2V (Cu, Fe) ZV	Not provided	In-panel	Exclusive duct	9.0	12.0	17.0	25.0
	Provided		Low power electrical duct				
5C-2V 5C-2V (Cu, Fe) ZV	Not provided	Panel-to-panel	Exclusive duct	5.1	7.6	11.0	16.0
	Provided		Low power electrical duct				
5C-FB 5C-FB (Cu, Fe) ZV	Not provided	Panel-to-panel	Exclusive duct	4.8	7.4	10.5	14.0
	Provided		Low power electrical duct				
7C-FB 7C-FB (Cu, Fe) ZV	Not provided	Panel-to-panel	Exclusive duct	4.2	5.8	7.6	10.0
	Provided		Low power electrical duct				
7C-FL 7C-FL (Cu, Fe) ZV	Not provided	Panel-to-panel	Exclusive duct	2.9	3.8	5.6	8.1
	Provided		Low power electrical duct				
11C-4AF 11C-4AF (Cu, Fe) ZV	Not provided	Panel-to-panel	Exclusive duct	1.5	2.3	3.2	4.6
	Provided		Low power electrical duct				
12C-5AF 12C-5AF (Cu, Fe) ZV	Not provided	Panel-to-panel	Exclusive duct	1.46	2.2	3.2	4.5
	Provided		Low power electrical duct				

Note:

1. Coaxial cables equivalent to the above can be applicable.
2. Signal attenuation: Pas (dB/km) shows typical values.

2.3.4 Coaxial Cable Connector

Table 2.7 lists connectors for coaxial cables.

Table 2.7 Coaxial Cable Connectors

Connector	Name	Type	Remarks	Manufacturer
Connection	BNC connector	BNC-P-3-Ni-CAu	For 3C-2V, Gold-plated contact	Dai-Ichi Electronic Ind.
	F-type connector	FSPW-5PEF	For 5C-2V, Silver-plated contact	Fujikura Ltd.
		Not specified	For 5C-FL, Silver-plated contact	Fujikura Ltd.
		F-5FB	For 5C-FB, Gold-plated contact	Fujikura Ltd.
		FSPW-7-Ni-CAu	For 7C-FL, Gold-plated contact	Fujikura Ltd.
		F-7FB	For 7C-FB, Gold-plated contact	Fujikura Ltd.
	Fitting connector	FI-12C-2.9-TC	For 12C-5AF, Gold-plated contact	Fujikura Ltd.
		FI-11C-4AF	For 11C-4AF, Gold-plated contact	Fujikura Ltd.
		FI-7CFL	For 7C-FB, Gold-plated contact	Fujikura Ltd.
Branch	T-type connector	BNC-TA-JPJ-Ni-CAu	For connection and branch of RIOD and RIOR modules.	Dai-Ichi Electronic Ind.
Conversion	Conversion adapter	T-0298	For conversion of BNC and F-type connectors	Yaskawa Electric
	Conversion connector	FTR-FJ	For conversion of fitting and F-type connectors	Fujikura Ltd.
Junction	Junction connector	F-A	For connecting F-type connectors to each other	Fujikura Ltd.
		FI-A	For connecting fitting connectors to each other	Fujikura Ltd.
Termination	Terminator	BNC-RC-75-Ni-CAu	For connection and termination of both ends of transmission line	Dai-Ichi Electronic Ind.

Note:

1. The connection loss of the above connectors is all 0 dB.
2. Waterproof the junction of the coaxial cable (e.g. wrap with self sealing tape). Also insulate the junction.
3. For connection, see par.7.2.1 "Connection".

2.3.5 MEMOBUS Cable Specifications

The RS-232C cable is used to connect the PP port with the PP or ACGC, host computer, etc. for communication. Standard cables shown in Table 2.8 are provided.

Table 2.8 List of Standard MEMOBUS Cables

Cable Type JZMSZ-	Length m (inch)	Equipment to be Connected
W1015-T1	2.5 (98.43)	P150
W1015-T2	15 (590.55)	
W1015-21	2.5 (98.43)	ACGC
W1015-22	15 (590.55)	

Table 2.9 Connection of JZMSZ-W1015

Pin No.	Signal Name	Direction	Pin No.	Signal Name
1	PGND	↔	1	PGND
2	TXD	→	3	RXD
3	RXD	←	2	TXD
4	RTS	↔	4	RTS
5	CTS	↔	5	CTS
6	DSR	→	9	DTR
20	DTR	←	6	DSR
7	SGND	↔	7	SGND

Note: In Table 2.9, the meanings of abbreviations are as follows:

- | | | | |
|--------|-------------------|-----------|---------------------|
| 1 PGND | protection ground | 5 CTS | clear to send |
| 2 TXD | transmission data | 6 DSR | data set ready |
| 3 RXD | received data | 7 SGND | signal ground |
| 4 RTS | request to send | 9, 20 DTR | data terminal ready |

2.4 FUNCTIONS

The IF64 has the following two functions.

- (a) Link between PCs
- (b) Link with the host computer, programming panel, ACGC, etc.

(a) Link between PCs

This function is used to interconnect PCs from the link port via the link line (coaxial cable). The PC link function allows the following link data to be shared among all stations.

Discrete: D0001 to D1024 (1024 points)

Register: R0001 to R1024 (1024 registers, 16 bits per register)

(b) Link with Host Computer

The computer can communicate with GL60S thru IF64 PP port by MEMOBUS protocol. The GL60S's of all stations interconnected with the link line can be monitored from the PP port. Multiple (maximum 32) GL60S's become MEMOBUS slaves, without using the modem.

3. INDICATIONS AND SWITCH SETTINGS

3.1 INDICATIONS

(1) There are seven LEDs on the front side of the IF64 to indicate the conditions. Table 3.1 shows the status indications.

- READY
- PP TX
- PP RX
- PP ERR
- LINK TX
- LINK RX
- LINK ERR

Fig. 3.1 LED Indications

Table 3.1 LED Indications

Indication	Description	LED Color
READY	Indicates that the IF64 is operating normally.	Green
PP TX	Lights during data transmission from the PP port. This LED lights by the bit stream of the transmission data.	Green
PP RX	Lights when data are received from the PP port. This LED lights by the bit stream of the reception data.	Green
PP ERR	Lights for about 10 ms in case error occurs in the communication (reception) at the PP port. Parity error, overrun error, framing error, CRC error, reception of illegal data	Red
LINK TX	Lights when transmitting data from the link port. This LED lights by the bit stream of the transmission data.	Green
LINK RX	Lights when receiving data from the link port. This LED lights by the bit stream of the reception data.	Green
LINK ERR	Lights for about 10 ms in case error occurs in the communication at the link port. Time-out error, reception of illegal data	Red

The above indications all light when power is initially supplied or after reset, but only the READY lamp will light after the self diagnosis of the module is completed. Other indicators light according to the condition of the communication.

(2) Status error is indicated by 3 LEDs ("READY," "PP ERR," "LINK ERR") on the front of the module.

Table 3.2 Errors and LED Indications

Errors	LED Indications			Remarks
	READY	PP ERR	LINK ERR	
ROM Error	●	●	○	Always checked.
RAM Error	●	○	●	Checked at power ON.
Common Memory Error	●	●	●	
Watchdog Error	●	●	●	Always checked.
Station Address Error	●	●	●	Checked at power ON.

Note: ○ : Lit ● : Extinguished ◐ : Blinded

Corrective Action

- In the events of ROM, RAM, common memory and watchdog errors, replace the module with new one.
- In the event of station address error, update the station address (using 32 or less) and reset the module.

3.2 SWITCH SETTINGS

The switches can be set before or after mounting the module. The condition of the switches is read and stored when power supply is turned on. When the setting is changed after power is supplied, depress the reset switch.

However, the current condition of the memory protect switch is always reflected.

3.2.1 Memory Protect

This switch is used to enable and prohibit changes in the program on the CPU on the base where the IF64 is mounted. The functions are the same as the memory protect switch for IOP, COMM.

This also functions as a memory protect for CPU of other stations connected via the link line. Note that the memory protect cannot be functioned from the programming panel of the other stations. This switch is effective to access from the in-station PP port.



Fig. 3.2 Memory Protect Switch

3.2.1 Memory Protect (Cont'd)

Table 3.3 Memory Protect Switch Function

Switch Position	Function
ON	Prohibits changes to be made in the CPU program from the PP port. Memory protect functions to access to the in-station CPU and CPU of other stations. However, the program can be changed from the PP of other stations.
OFF	Allows changes to be made to the CPU program from the PP port.

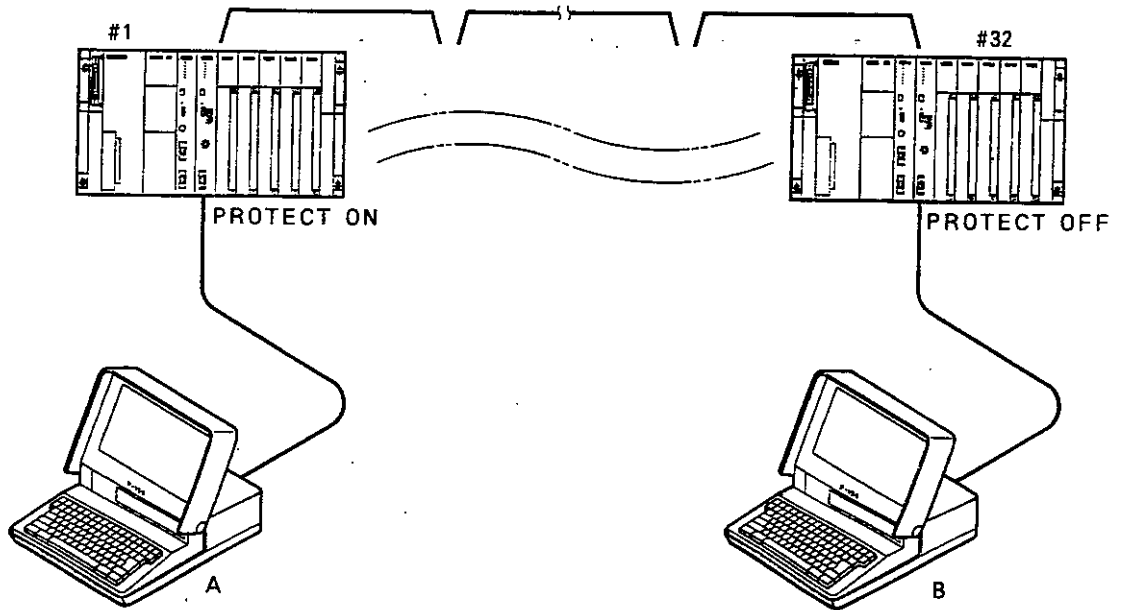

Fig. 3.3 Example of Memory Protect

As shown in Fig. 3.3, changing any CPU program of stations 1 to 32 from the PP of A is prohibited. Change of any CPU program of stations 1 to 32 from the PP of B is enabled.

3.2.2 Station Address

The address of IF64 is set by the two rotary switches on the front of the module. Setting for 1 to 32 (decimal 2-digit) is available. The module does not operate if other settings have been made.

When the address is changed after the power is supplied, depress the reset switch and initialize again. The change in the address will not be reflected unless the reset switch is depressed.

This address becomes the link port and PP port address of that station. Therefore, when communicating with the CPU of that station with the PP, the value set by this switch is the device address.

3.2.3 Setting Transmission Rate

The transmission rate of the link port is set by the DIP switch (1SW) on the front of the module. (See Table 3.4.)

If the transmission rate setting is changed after the power is supplied, depress the reset switch of the module and initialize again. The change of the transmission rate setting will not be reflected unless the reset switch is depressed.

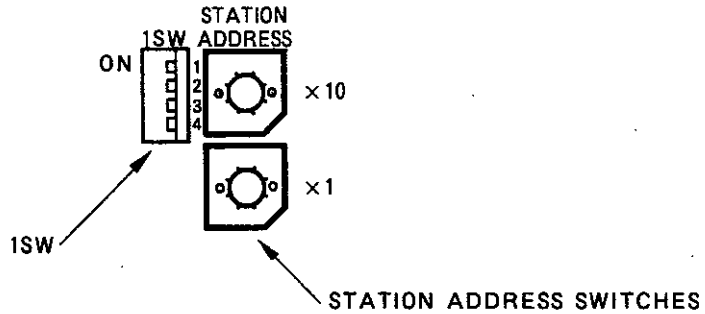

Fig. 3.4 Station Address Switches and DIP Switch 1SW

3.2.4 Other Settings

Selection can be made on whether to hold the link data state on the failure station or to clear the state. This selection can be made on each station. Select either mode on the DIP switch (1SW) on the front of the module. (See Table 3.4.)

Table 3.4 1SW Setting

SW Mode No.	Settings		
1	Must be OFF position.		
2	ON	Hold mode: Holds the link data immediately before the station* malfunctions.	
	OFF	Clear mode: Resets the link data on the failure station* to "OFF" or "0."	
3, 4	3SW	4SW	Transmission rate
	ON	ON	4 Mbps
	OFF	ON	2 Mbps
	ON	OFF	1 Mbps
	OFF	OFF	0.5 Mbps

* This station is disconnected from the transmission line by some erroneous state, as power off.

Note: The same baud rate should be set to all stations in the system.

4. INTER-PC LINK FUNCTION

4.1 TRANSMISSION/RECEPTION OF LINK DATA

The IF64 has a memory for link data (hereafter called link memory). The CPU of each station exchanges the link data by reading-out/writing-in each IF64 link memory, according to the allocation (see par. 4.2). The IF64 also transmits data according to the allocation (see par. 4.2), to exchange inter-station link data.

The link memory area written for each station is determined by the allocation (see par. 4.2). The IF64 of each station periodically transmits the link data written by the CPU to all stations. The IF64 writes the received link data into the in-station link memory. Thus, the contents of the link memory of all stations are kept the same.

Fig. 4.1 shows the link data flow in 4-station system.

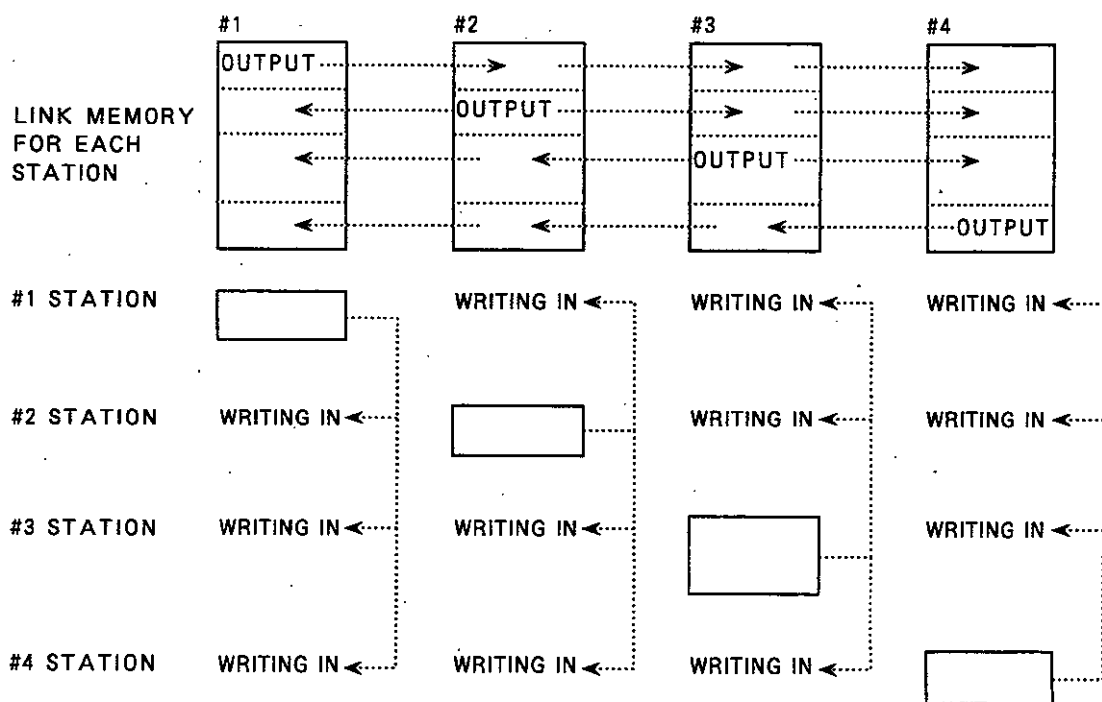

Fig. 4.1 Link Data Flow in 4-Station System

NOTE

The link data shown in Fig. 4.1 is written into the link memory of IF64. Allocation (see par. 4.2) is required for the CPU to refer to this link data. If no allocation is set for reference, it becomes "0" or "OFF."

The link data includes discrete and register types. The reference numbers are determined, as shown in Table 4.1.

Table 4.1 Link Reference Number

Type	Reference Number
Discrete	D0001, D0002, D0003, D0004, ..., D1024
Register	R0001, R0002, R0003, R0004, ..., R1024

4.2 ALLOCATION AND ITS OPERATION

4.2.1 Allocation

Allocation is required to prescribe the exchange of link data between PCs. The allocation is performed from the programming panel. Operation for the allocation is described in the next section.

Allocation of each station is made against each CPU. The allocation is stored in the backup memory of the CPU of each station.

The allocation includes the following write MAP (WMAP) and read MAP (RMAP.)

(1) WMAP

Decides the link data transmitted by the CPU as the output to other stations via the IF64. Without setting the WMAP, the link data of the station cannot be transmitted to other stations.

(2) RMAP

Decides the link data that the CPU refers to.

When the CPU refers to link data not set on the RMAP, the link data becomes "0" or "OFF."

NOTE

The link data referred by the CPU is link data transmitted from other stations. Therefore, the WMAP corresponding to the RMAP should also be set on other stations.

The above allocation of the WMAP and RMAP must be set on the CPU of each station. The allocation is made by the reference and size of the link data, as shown in Table 4.2.

4.2.1 ALLOCATION (Cont'd)

Table 4.2 Allocation Data

Allocation Item	Description
Head Reference of Link Data	Specifies the start number of the link data. Discrete: DX (D0001 to D1009) $X = 16n + 1$ ($n = 0, 1, 2 \dots 63$) Register: RY (R0001 to R1024)
Link Data Size	The link data is specified by sequential numbers. The allocation is made by the head reference and the size. Discrete: 16-point unit Register: 1-register unit

Note: The maximum value of the WMAP of a single station is a total of 512 bytes of discrete and register.

(Discrete points \div 8 + registers \times 2 \leq 512)

4.2.2 Operation for Allocation

The operation for allocation is accomplished in one of the two following allocation modes.

- (1) Batch allocation mode
- (2) Individual allocation mode

(1) Batch Allocation Mode

Allocation under this mode is always made from the PP port of the IF64. The compatibility of the WMAP between all stations and the RMAP of each station is checked under this mode.

There are two operations; the "create link" operation and the "edit link" operation.

Figs. 4.2 and 4.3 show examples of batch allocation displays.

DISCRETE LINK T-COP					UNIT:001	PROGRAM MODE			
LINK STATION NO:01									
READ LINK					WRITE LINK				
NO	REF #	POINTS	REF #	POINTS	NO	REF #	POINTS	REF #	POINTS
1			D0001	0016	17	---	---	---	---
2	D0017	0016	D0017	0016	18	---	---	---	---
3	D0033	0016	D0033	0016	19	---	---	---	---
4	D0049	0016	D0049	0016	20	---	---	---	---
5	D0065	0016	D0065	0016	21	---	---	---	---
6	D0081	0016	D0081	0016	22	---	---	---	---
7	D0097	0016	D0097	0016	23	---	---	---	---
8	D0113	0016	D0113	0016	24	---	---	---	---
9	D0129	0016	D0129	0016	25	---	---	---	---
10	D0145	0016	D0145	0016	26	---	---	---	---
11	D0161	0016	D0161	0016	27	---	---	---	---
12	D0177	0016	D0177	0016	28	---	---	---	---
13	D0193	0016	D0193	0016	29	---	---	---	---
14	D0209	0016	D0209	0016	30	---	---	---	---
15	D0225	0016	D0225	0016	31	---	---	---	---
16	D0241	0016	D0241	0016	32	---	---	---	---

STOPPED SC

1 SELECT 2+DISCRETE3 4 5 6 AR:00000 7PREVIOUS8 9 NEXT MENU MENU

(a) Example 1

DISCRETE LINK T-COP					UNIT:001	PROGRAM MODE			
LINK STATION NO:01									
READ LINK					WRITE LINK				
NO	REF #	POINTS	REF #	POINTS	NO	REF #	POINTS	REF #	POINTS
1			D0001	0016	17	---	---	---	---
2	D0017	0240	D0017	0016	18	---	---	---	---
3	---	---	D0033	0016	19	---	---	---	---
4	---	---	D0049	0016	20	---	---	---	---
5	---	---	D0065	0016	21	---	---	---	---
6	---	---	D0081	0016	22	---	---	---	---
7	---	---	D0097	0016	23	---	---	---	---
8	---	---	D0113	0016	24	---	---	---	---
9	---	---	D0129	0016	25	---	---	---	---
10	---	---	D0145	0016	26	---	---	---	---
11	---	---	D0161	0016	27	---	---	---	---
12	---	---	D0177	0016	28	---	---	---	---
13	---	---	D0193	0016	29	---	---	---	---
14	---	---	D0209	0016	30	---	---	---	---
15	---	---	D0225	0016	31	---	---	---	---
16	---	---	D0241	0016	32	---	---	---	---

STOPPED SC

1 SELECT 2+DISCRETE3 4 5 6 AR:00000 7PREVIOUS8 9 NEXT MENU MENU

(b) Example 2

Note: Each allocation of the above examples has the same meaning, i.e. the link operation is identical.

Fig. 4.2 Discrete Batch Allocation

4.2.2 Operation for Allocation (Cont'd)

REGISTER LINK T-COP					UNIT:001		PROGRAM MODE		
LINK STATION NO:01									
READ LINK					WRITE LINK				
NO	REF #	SIZE	REF #	SIZE	NO	REF #	SIZE	REF #	SIZE
1			R0001	0008	17				
2	R0009	0008	R0009	0008	18				
3	R0017	0008	R0017	0008	19				
4	R0025	0008	R0025	0008	20				
5	R0033	0008	R0033	0008	21				
6	R0041	0008	R0041	0008	22				
7	R0049	0008	R0049	0008	23				
8	R0057	0008	R0057	0008	24				
9	R0065	0008	R0065	0008	25				
10	R0073	0008	R0073	0008	26				
11	R0081	0008	R0081	0008	27				
12	R0089	0008	R0089	0008	28				
13	R0097	0008	R0097	0008	29				
14	R0105	0008	R0105	0008	30				
15	R0113	0008	R0113	0008	31				
16	R0121	0008	R0121	0008	32				

STOPPED SC

1 SELECT 2 DISCRETE 3 4 5 6 AR:00000 7 PREVIOUS 8 NEXT
 STATION +REGISTER MENU MENU

(a) Example 1

REGISTER LINK T-COP					UNIT:001		PROGRAM MODE		
LINK STATION NO:01									
READ LINK					WRITE LINK				
NO	REF #	SIZE	REF #	SIZE	NO	REF #	SIZE	REF #	SIZE
1			R0001	0008	17				
2	R0009	0120	R0009	0008	18				
3			R0017	0008	19				
4			R0025	0008	20				
5			R0033	0008	21				
6			R0041	0008	22				
7			R0049	0008	23				
8			R0057	0008	24				
9			R0065	0008	25				
10			R0073	0008	26				
11			R0081	0008	27				
12			R0089	0008	28				
13			R0097	0008	29				
14			R0105	0008	30				
15			R0113	0008	31				
16			R0121	0008	32				

STOPPED SC

1 SELECT 2 DISCRETE 3 4 5 6 AR:00000 7 PREVIOUS 8 NEXT
 STATION +REGISTER MENU MENU

(b) Example 2

Note: Each allocation of the above examples has the same meaning, i.e. the link operation is identical.

Fig. 4.3 Register Batch Allocation

(a) Create Link

The allocation data of all stations on the PP are newly created. After creating the allocation data on the PP, the data are loaded onto the GL60S, and the allocation of each station is updated.

Operation Procedure

Connect the PP to the IF64 PP port.

(Any IF64 port is available as long as it is connected to the link line.)

Allocate according to the following operation flow.

Critical Points

- Connect the PP to the PP port of the IF64.
- Be sure to connect a single PP per system.
- Duplicate allocation is prohibited in link allocation.

4.2.2 Operation for Allocation (Cont'd)

■ Link Allocation Storing

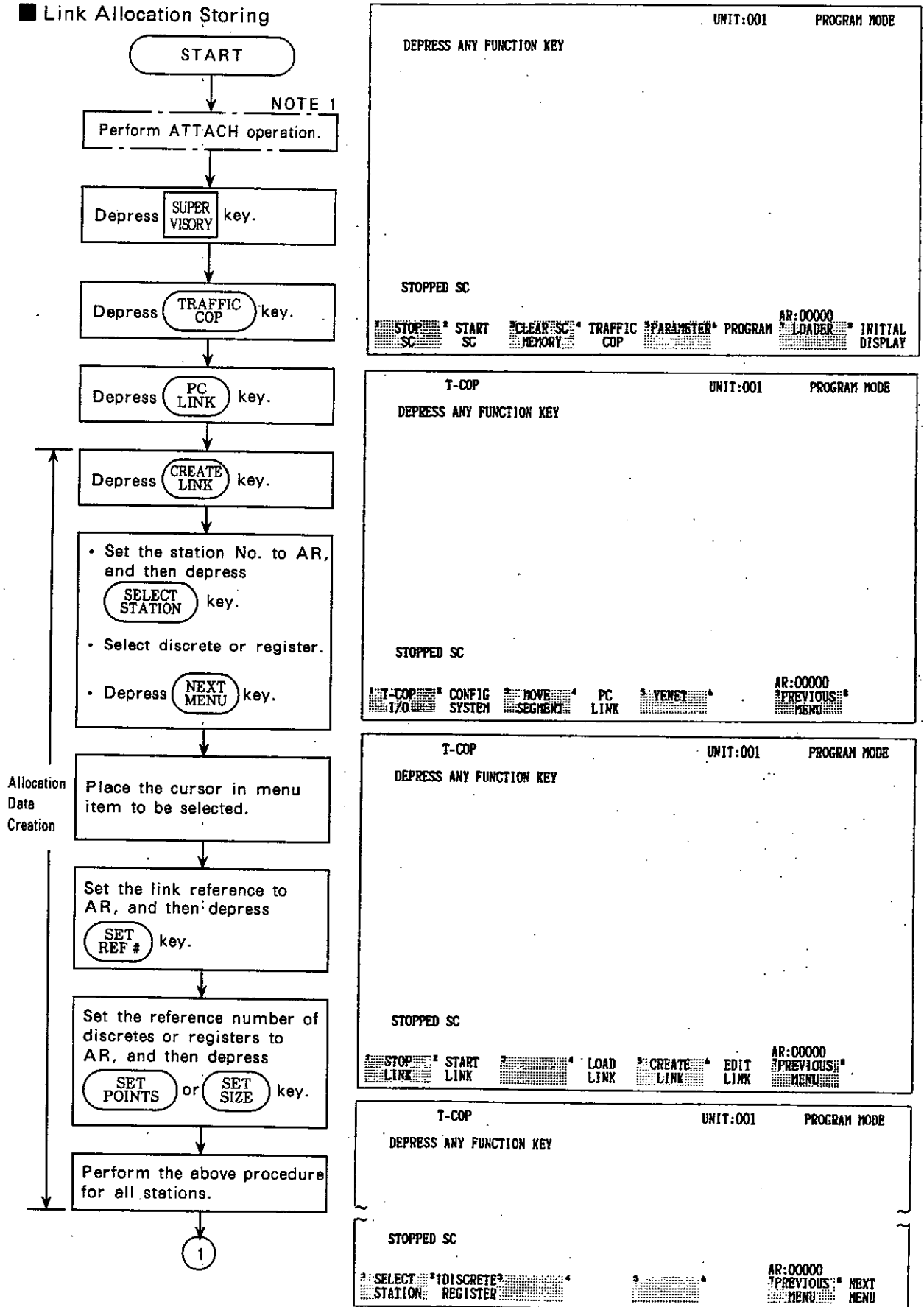

Fig. 4.4 Allocation Flow — No.1

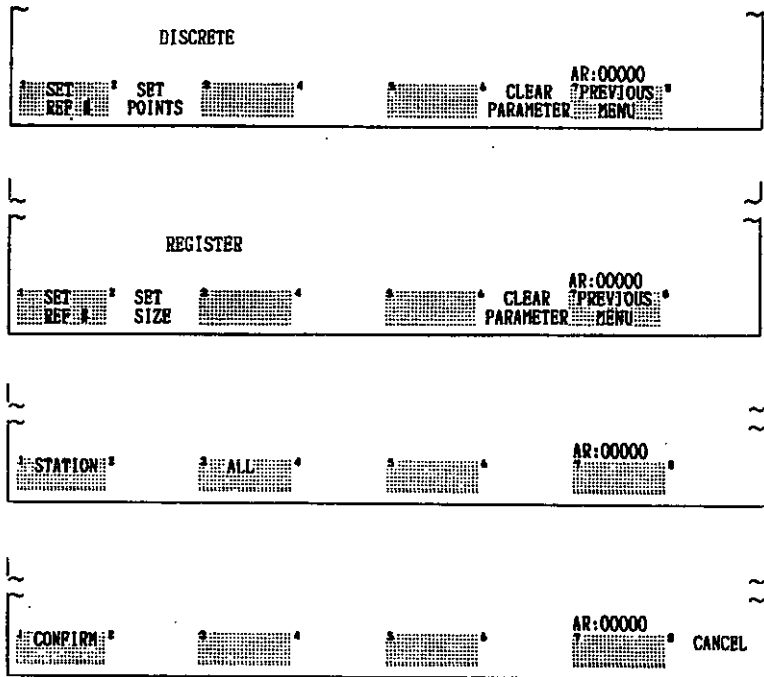
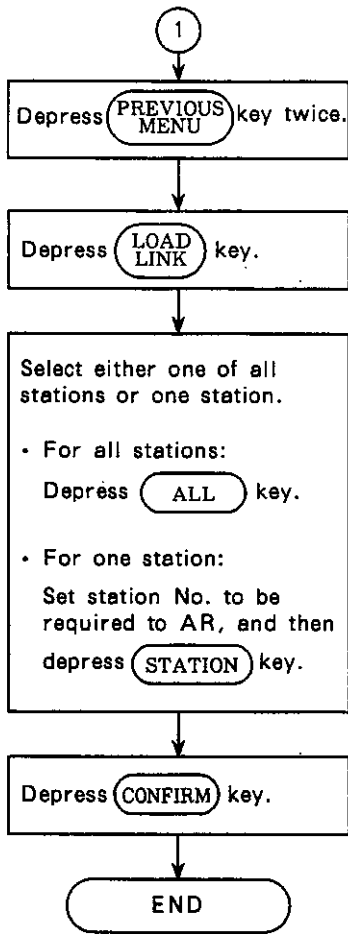

Fig. 4.4 Allocation Flow — No.2

NOTE

1. When ATTACH operation has already been completed, this step can be skipped.
2. When the values are set to REF#POINTS or REF#SIZE, they are stored in the allocation table.
3. Depressing (CLEAR PARAMETER) key clears the link allocation shown at the cursor.
4. Depress (CREATE LINK) to automatically display the station #1 discrete.
5. The WMAP of all stations are displayed in a batch, so the contents are the same for stations #1 through 32. No duplicate allocation in the WMAP is permitted.
6. Duplicate allocation of the RMAP within a single station is also prohibited.
7. Stop the link data communication to load the allocation data using (STOP LINK). (START LINK) restarts the communication.

4.2.2. Operation for Allocation (Cont'd)

(b) Edit Link

The PP reads the allocation data of the GL60S connected to the link line, and automatically checks for duplication. The read allocation can also be changed and reset.

Operation Procedure

Connect the PP to the IF64 PP port.

(Any IF64 port is available as long as it is connected to the link line.)

Allocate according to the following operation flow.

Critical Points

- Connect the PP to the PP port of the IF64.
- Be sure to connect a single PP per system.
- Duplicate allocation is prohibited in link allocation.

■ Link Allocation Storing

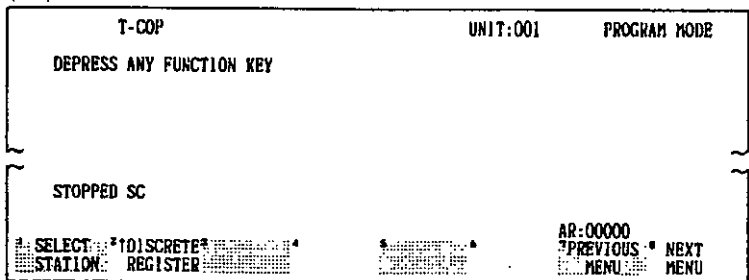
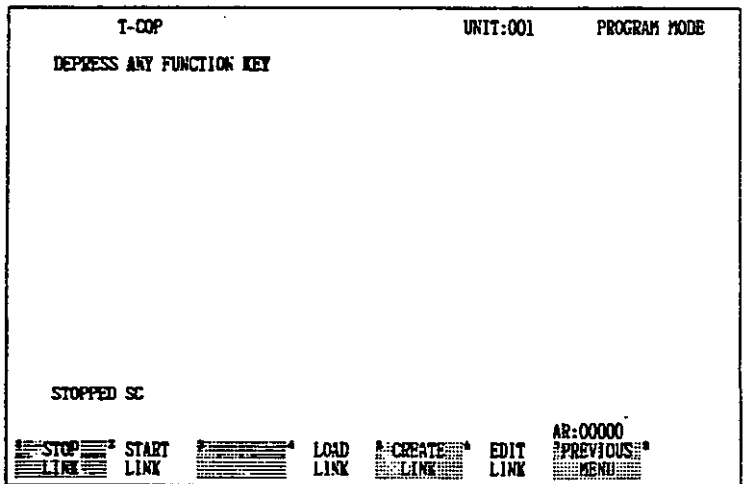
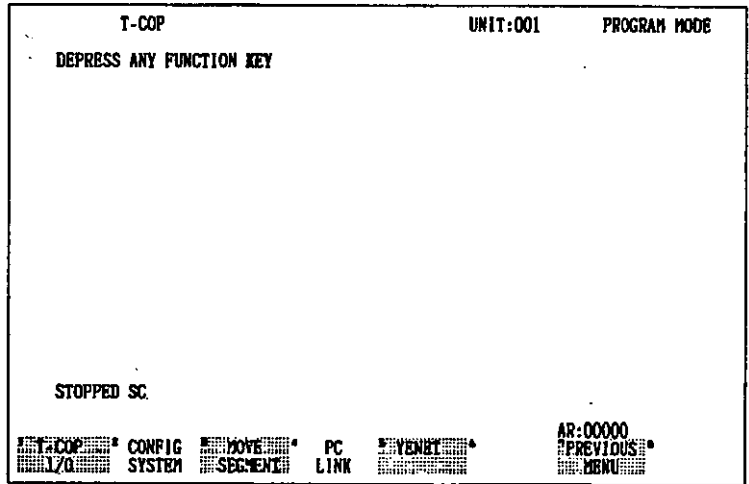
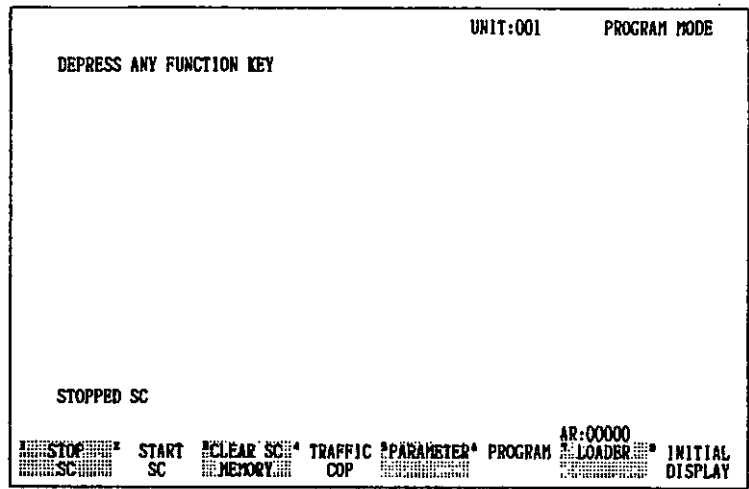
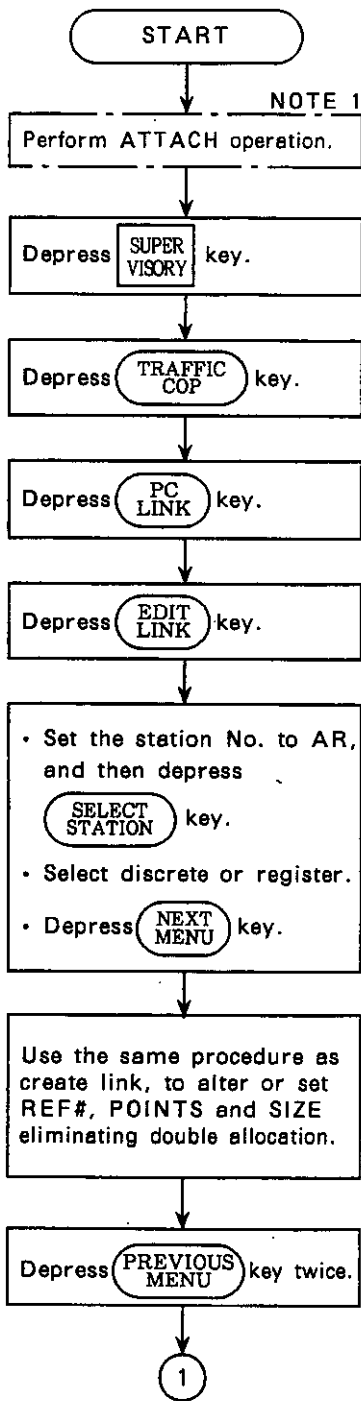

Fig. 4.5 Allocation Flow — No.1

4.2.2 Operation for Allocation (Cont'd)

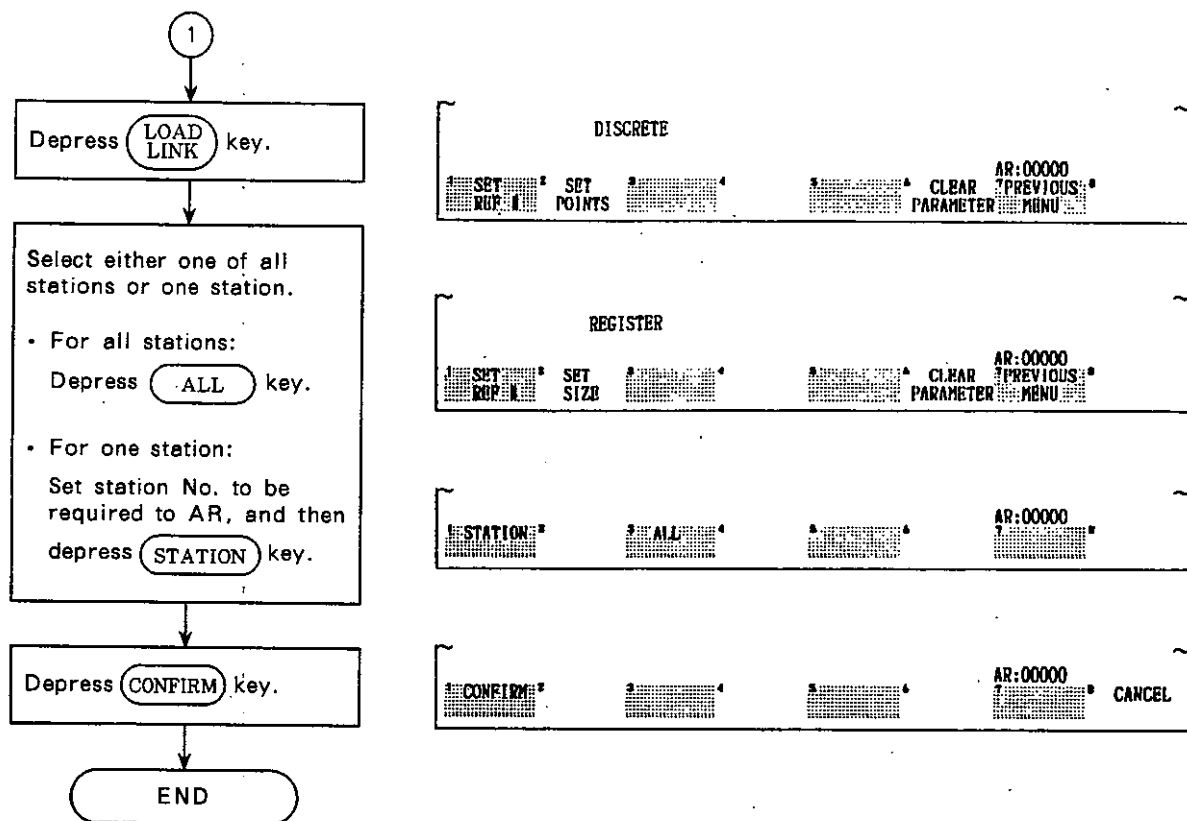

Fig. 4.5 Allocation Flow — No.2

NOTE

1. When ATTACH operation has already been completed, this step can be skipped.
2. When the values are set to REF#POINTS or REF#SIZE, they are stored in the allocation table.
3. Depressing CLEAR PARAMETER key clears the link allocation shown at the cursor.
4. Depress EDIT LINK key to read the allocation of all stations. The following error message is displayed if duplication is found in the WMAP.
"REFERENCE MULTIPLY IN WRITE LINK T-COP ST XX ST XX ..."
There can be no duplication in the RMAP.
5. Completely clear all allocation duplications. If a duplication remains, no writing into the station is permitted.
6. If exited from the supervisory mode during the allocation operation, all previously allocated data will be lost.
7. Stop the link data communication using STOP LINK.
START LINK restarts the communication.

(c) Stop and Restart of Link Data Communication

During link data communication, changing an allocation may occur erroneous link operation. In this case the link data communication can be stopped as needed.

(i) Link data communication stop (STOP LINK) operation procedure

Connect the PP to the IF64 PP port.

(Any IF64 port is available as long as it is connected to the link line.)

Stop the link data communication according to the following operation flow.

Critical Points

- Connect the PP to the PP port of the IF64.
- Be sure to connect a single PP per system.
- Especially, in use of batch allocation mode, it is recommended that the link data communication be stopped.

4.2.2 Operation for Allocation (Cont'd)

■ Link Data Communication Stop

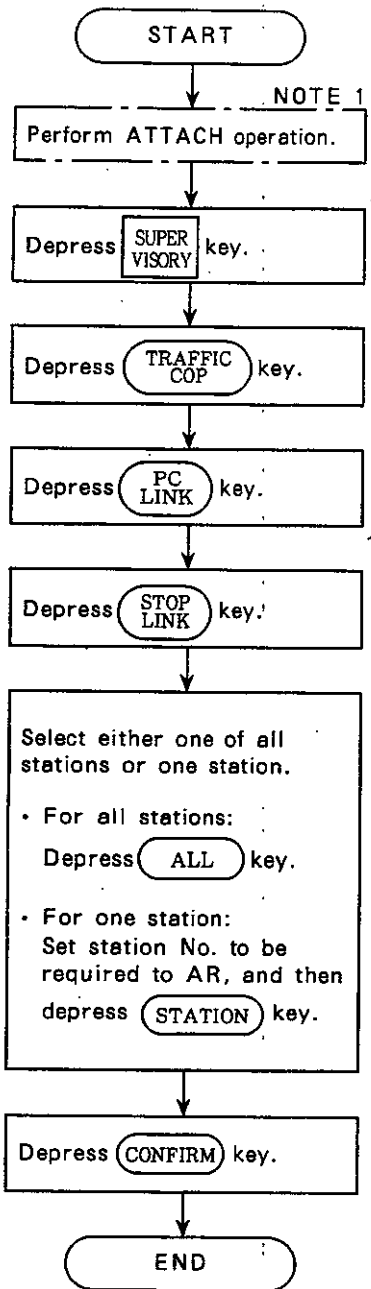

NOTE

1. When ATTACH operation has already been completed, this step can be skipped.
2. When this procedure has already been completed, it can be skipped.

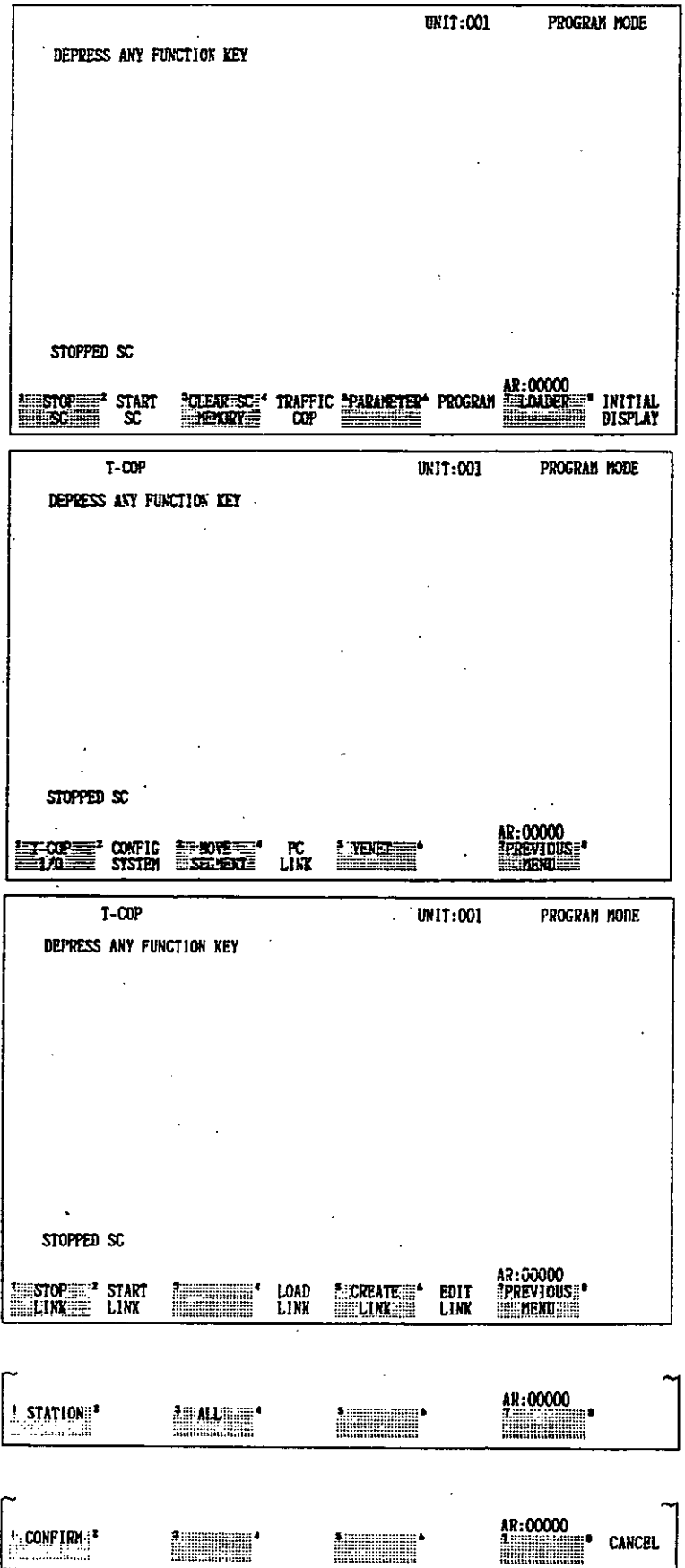

Fig. 4.6 Operation Flow for Link Data Communication Stop

(ii) Link data communication restart (START LINK)

Operation Procedure

Connect the PP to the IF64 PP port.

(Any IF64 port will suffice as long as it is connected to the link line.)

Restart the link data communication according to the following operation flow.

Critical Points

- Connect the PP to the PP port of the IF64.
- Be sure to connect a single PP per system.

4.2.2 Operation for Allocation (Cont'd)

■ Link Data Communication Restart

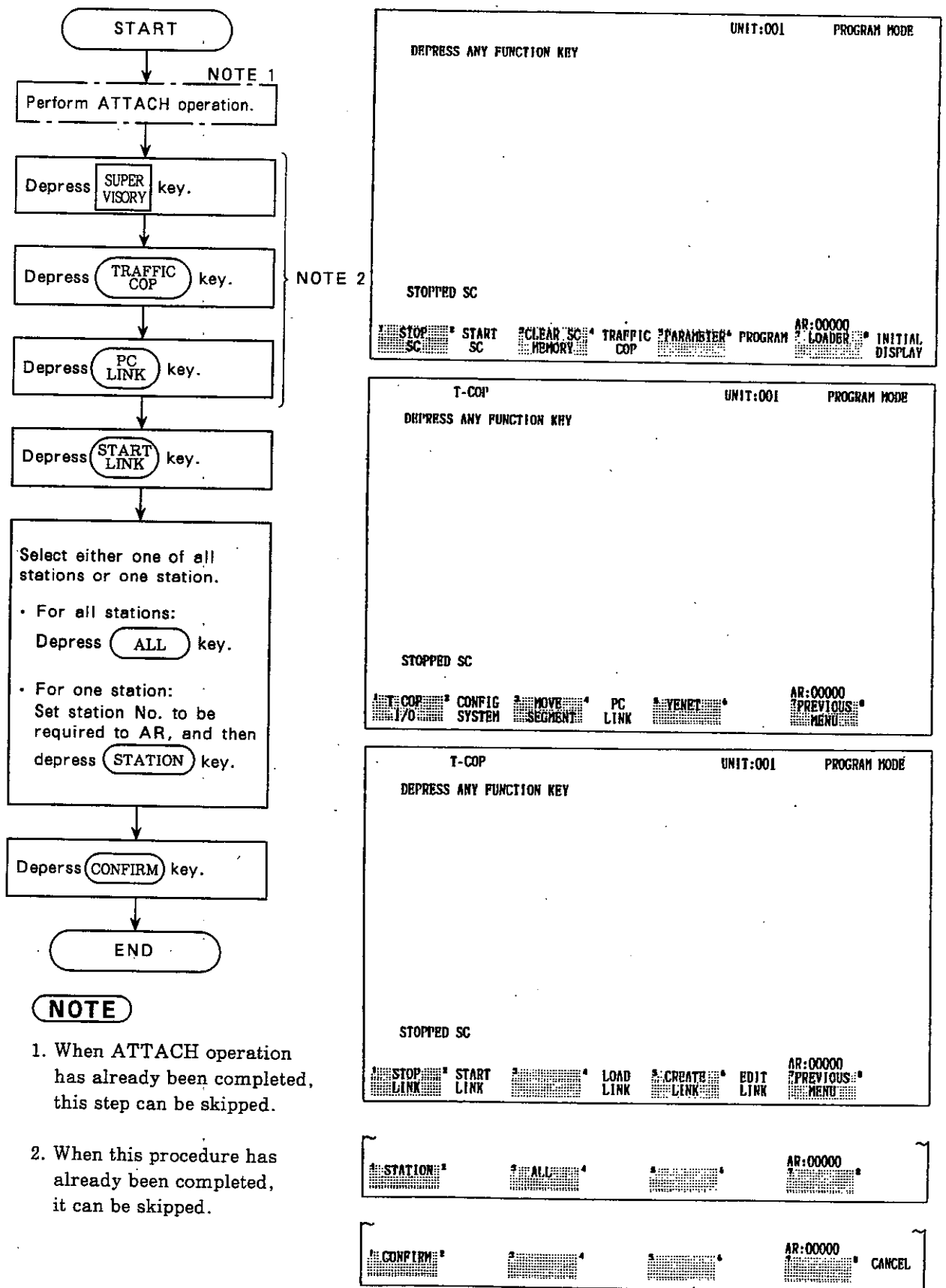

Fig. 4.7 Operation Flow for Link Data Communication Restart

(2) Individual Allocation Mode

Under this mode, the link allocation is made on the specified station alone. The operator should check the compatibility with the allocation of other stations. In other words, no alarm occurs when WMAP duplicates that of other stations. However, the compatibility of the RMAP is checked by the PP, and alarm does occur if any duplication is found.

Fig. 4.8 shows example of individual allocation displays.

T-COP LINK					UNIT:001					PROGRAM MODE				
NO	DISCRETE		REGISTER		NO	DISCRETE		REGISTER		NO	DISCRETE		REGISTER	
	REF #	POINTS	REF #	SIZE		REF #	POINTS	REF #	SIZE		REF #	POINTS	REF #	SIZE
1	D0001	0016	R0001	0008	17	---	---	---	---	17	---	---	---	---
2	D0017	0240	R0009	0120	18	---	---	---	---	18	---	---	---	---
3	---	---	---	---	19	---	---	---	---	19	---	---	---	---
4	---	---	---	---	20	---	---	---	---	20	---	---	---	---
5	---	---	---	---	21	---	---	---	---	21	---	---	---	---
6	---	---	---	---	22	---	---	---	---	22	---	---	---	---
7	---	---	---	---	23	---	---	---	---	23	---	---	---	---
8	---	---	---	---	24	---	---	---	---	24	---	---	---	---
9	---	---	---	---	25	---	---	---	---	25	---	---	---	---
10	---	---	---	---	26	---	---	---	---	26	---	---	---	---
11	---	---	---	---	27	---	---	---	---	27	---	---	---	---
12	---	---	---	---	28	---	---	---	---	28	---	---	---	---
13	---	---	---	---	29	---	---	---	---	29	---	---	---	---
14	---	---	---	---	30	---	---	---	---	30	---	---	---	---
15	---	---	---	---	31	---	---	---	---	31	---	---	---	---
16	---	---	---	---	32	---	---	---	---	32	---	---	---	---

STOPPED SC

1 SET REF# 2 SET POINTS 3 [] 4 [] 5 [] 6 CLEAR PARAMETER 7 PREVIOUS MENU 8 [] AR:00000

(a) Example 1

T-COP LINK					UNIT:001					PROGRAM MODE				
NO	DISCRETE		REGISTER		NO	DISCRETE		REGISTER		NO	DISCRETE		REGISTER	
	REF #	POINTS	REF #	SIZE		REF #	POINTS	REF #	SIZE		REF #	POINTS	REF #	SIZE
1	D0001	0016	R0001	0008	17	---	---	---	---	17	---	---	---	---
2	D0017	0016	R0009	0008	18	---	---	---	---	18	---	---	---	---
3	D0033	0016	R0017	0008	19	---	---	---	---	19	---	---	---	---
4	D0049	0016	R0025	0008	20	---	---	---	---	20	---	---	---	---
5	D0065	0016	R0033	0008	21	---	---	---	---	21	---	---	---	---
6	D0081	0016	R0041	0008	22	---	---	---	---	22	---	---	---	---
7	D0097	0016	R0049	0008	23	---	---	---	---	23	---	---	---	---
8	D0113	0016	R0057	0008	24	---	---	---	---	24	---	---	---	---
9	D0129	0016	R0065	0008	25	---	---	---	---	25	---	---	---	---
10	D0145	0016	R0073	0008	26	---	---	---	---	26	---	---	---	---
11	D0161	0016	R0081	0008	27	---	---	---	---	27	---	---	---	---
12	D0177	0016	R0089	0008	28	---	---	---	---	28	---	---	---	---
13	D0193	0016	R0097	0008	29	---	---	---	---	29	---	---	---	---
14	D0209	0016	R0105	0008	30	---	---	---	---	30	---	---	---	---
15	D0225	0016	R0113	0008	31	---	---	---	---	31	---	---	---	---
16	D0241	0016	R0121	0008	32	---	---	---	---	32	---	---	---	---

STOPPED SC

1 SET REF# 2 SET POINTS 3 [] 4 [] 5 [] 6 CLEAR PARAMETER 7 PREVIOUS MENU 8 [] AR:00000

(b) Example 2

Fig. 4.8 Individual Allocation

4.2.2 . Operation for Allocation (Cont'd)

NOTE

1. Each allocation of the examples in Fig.4.8 has the same meaning, i.e. the link operation is identical.
2. RMAP and WMAP are allocated in one station. Up to 512 bytes (See Note of Table 4.2.) are available in total of maximum discrettes and registers for both RMAP and WMAP each station.

Operation Procedure

Connect the PP to the PP port.

(Any of the IOP, COMM, RIOR, or IF64 PP ports.)

Allocate according to the following operation flow.

Critical Points

- Stop the GL60S when allocating the link.
- Duplicate allocation is prohibited in link allocation.

■ Link Allocation Storing

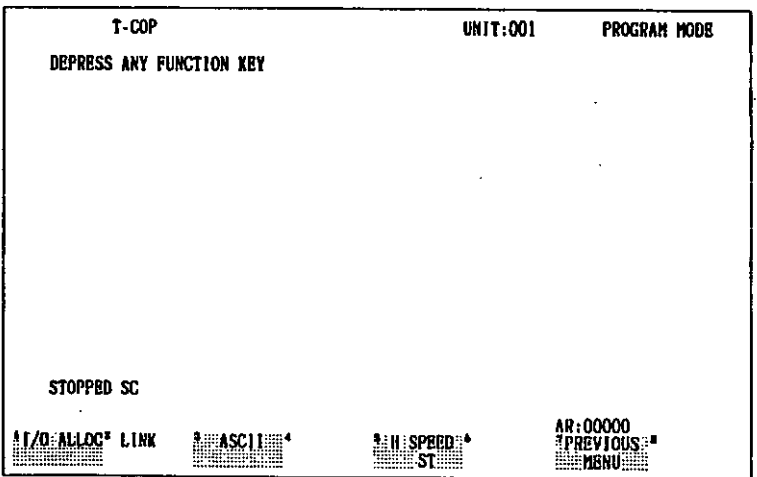
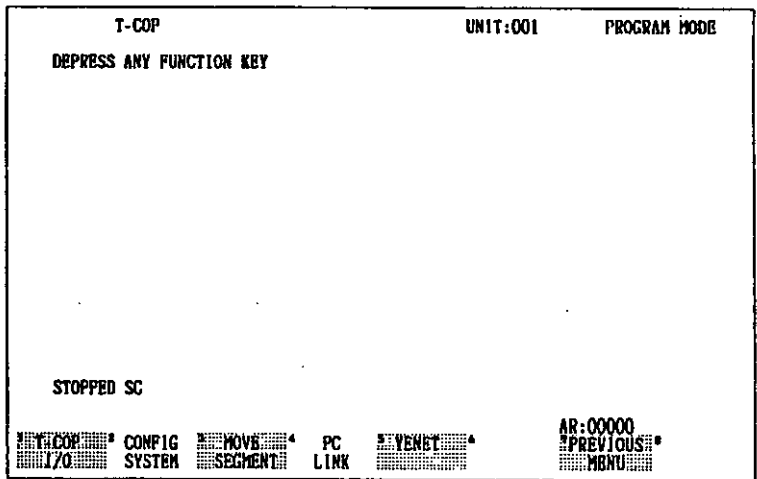
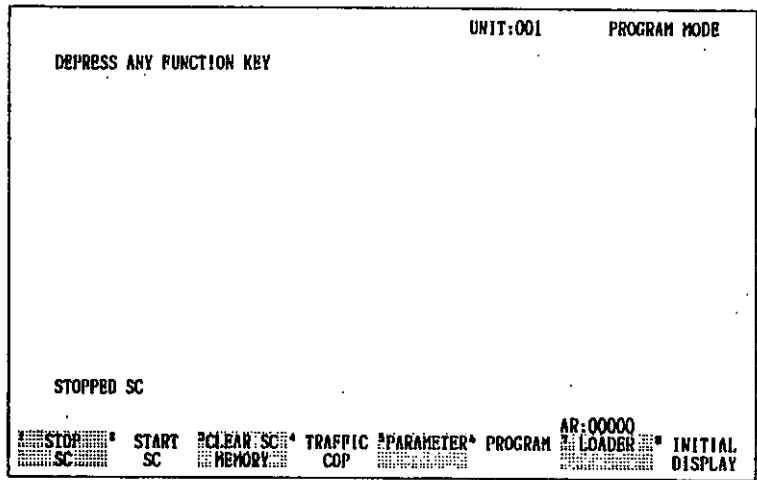
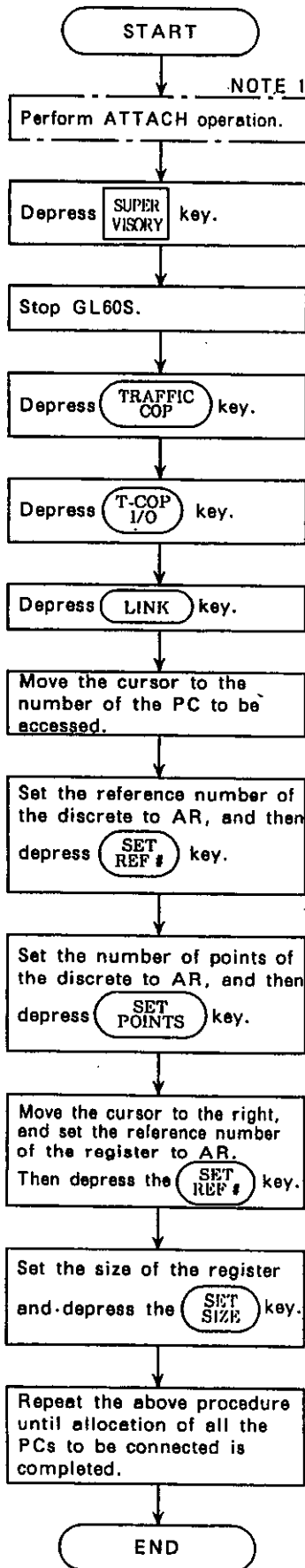

Fig. 4.9 Allocation Flow

4.2.2 Operation for Allocation (Cont'd)

NOTE

1. When ATTACH operation has already been completed, this step can be skipped.
2. When the values are set to REF#POINTS or REF#SIZE, they are stored in the allocation table.
3. Depressing **CLEAR PARAMETER** key clears the link allocation shown at the cursor.

T-COP LINK					UNIT:XXX			PROGRAM MODE	
NO	DISCRETE		REGISTER		NO	DISCRETE		REGISTER	
	REF #	POINTS	REF #	SIZE		REF #	POINTS	REF #	SIZE
1	-----	-----	-----	---	17	-----	-----	-----	---
2	-----	-----	-----	---	18	-----	-----	-----	---
3	-----	-----	-----	---	19	-----	-----	-----	---
4	-----	-----	-----	---	20	-----	-----	-----	---
5	-----	-----	-----	---	21	-----	-----	-----	---
6	-----	-----	-----	---	22	-----	-----	-----	---
7	-----	-----	-----	---	23	-----	-----	-----	---
8	-----	-----	-----	---	24	-----	-----	-----	---
9	-----	-----	-----	---	25	-----	-----	-----	---
10	-----	-----	-----	---	26	-----	-----	-----	---
11	-----	-----	-----	---	27	-----	-----	-----	---
12	-----	-----	-----	---	28	-----	-----	-----	---
13	-----	-----	-----	---	29	-----	-----	-----	---
14	-----	-----	-----	---	30	-----	-----	-----	---
15	-----	-----	-----	---	31	-----	-----	-----	---
16	-----	-----	-----	---	32	-----	-----	-----	---

STOPPED SC

1 SET 2 SET 3 4 5 6 CLEAR 7PREVIOUS 8
REF # POINTS PARAMETER MENU

AR:XXXXX

Fig. 4.10 Allocation Display

The allocation on the screen corresponding to its unit number is the WMAP. The remaining parts are the RMAP. (See Fig.4.10. The allocation at No.1 is the WMAP of this station.)



The RMAP has no relation to the station number. Set the head reference and size of the link data at other numbered position. In other words, it is not necessary to be in a form corresponding to the WMAP of other stations.

4.2.3 Notes on Changing the Allocation

- (1) The compatibility of the allocation temporarily breaks during the allocation. If link data communication is made at this time, reference to the link data cannot be done correctly.

Normally, stop the link data communication before changing the allocation.

- (2) In case change was made with the wrong reference area, as shown below, the old data before change will be referred to.

In the example of Fig. 4.11, the WMAP of station #3 was reduced, but the RMAPs of other stations were left as they were. In this case, the shaded part  will not be sent to other stations. Therefore, the shaded part  will have the data before the allocation was changed.

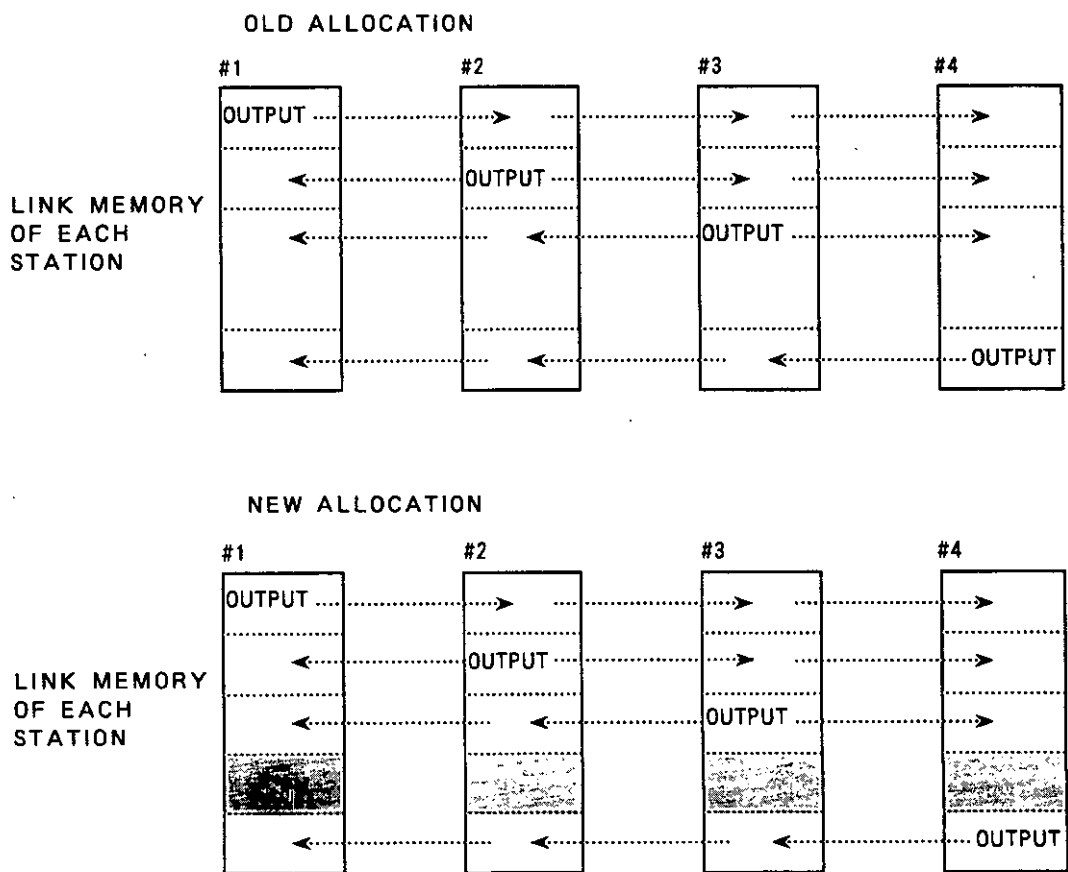

Fig. 4.11 Wrong Compatibility in Allocation

- (3) When allocation is made under batch allocation mode, all stations must be ready state. The allocation is not written into inactive stations. The allocation must be made once more, if any of the stations is inactive.

5. LINK FUNCTION WITH HOST COMPUTER BY PP PORT

5.1 MONITORING LINK DATA

The PP port supports the MEMOBUS protocol communication. Connect the personal computer, programming panel, or ACGC to the PP port to monitor all link data. Monitoring and changing status not only of the link data, but also of the coil, holding register, etc. of all the stations connected to the link line can be accomplished. Since all the GL60S's are connected by the link line, no modem is required between GL60S's. A maximum of 32 MEMOBUS slaves are considered to be connected to a single link line.

- Connection can be made to the IF64 PP port of any station.
- Multiple programming panels, ACGCs, and personal computers can be connected to a single system.
- The device address of the destination of communication is the station number of the IF64 of each station.
- There are 14 reception buffers in a station. One slave can simultaneously communicate with 14 masters. If communication exceeds this limit, the 15th and later reception messages are disregarded.
- The transmission/reception buffer of the MEMOBUS slave and the transmission/reception buffer of the link data are different. Therefore, increase in the traffic of the MEMOBUS will not affect the communication of the link data.

5.2 CONNECTION OF PROGRAMMING PANEL

The PP can be connected to the PP port to set allocations or to change and monitor the program.

- Connection can be made to the IF64 PP port of any station.
- Multiple PPs can be connected to a single system.
- The device address is the station number of the IF64 of each station, when attaching.
- When multiple PPs are attached to a single station under the program mode, the last attached PP will come to the program mode.
- There is a single program mode PP for the CPU of each station. When already attached under the program mode from the IOP or COMM, the following error message will be given.
"CANNOT LOGIN-UNIT HAS PROGRAMMER ATTACHED"

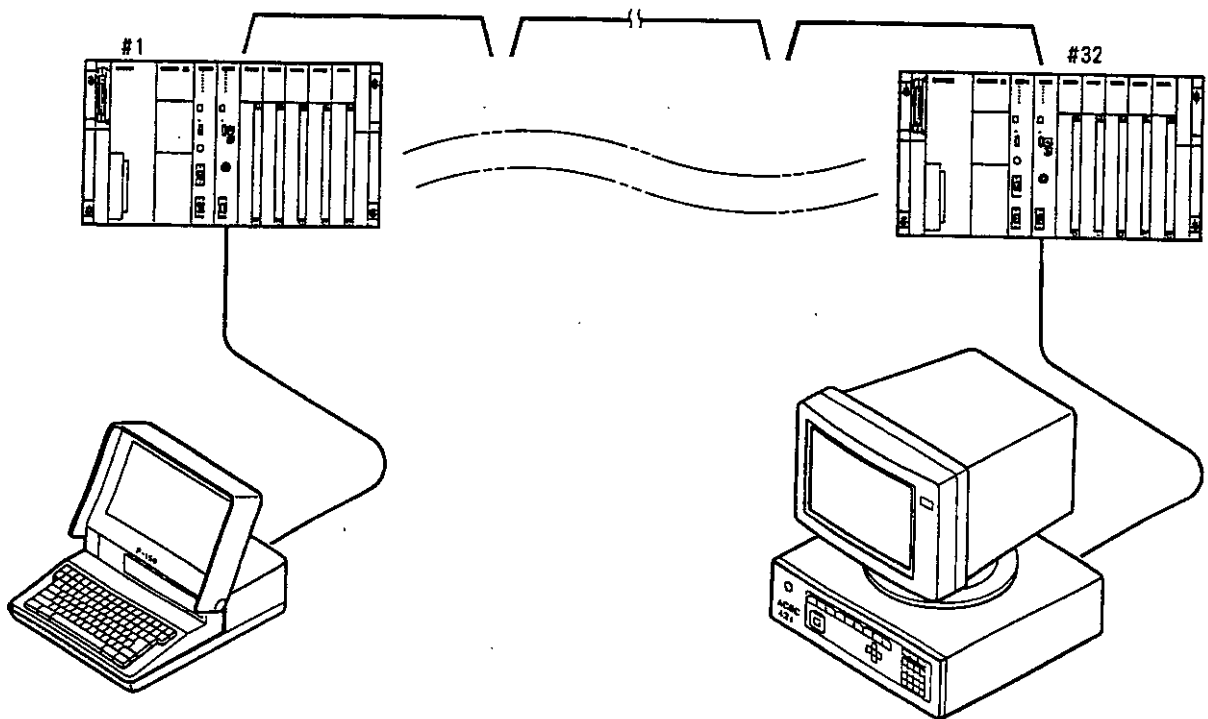

Fig. 5.1 Connection to PP Port

6. TRANSMISSION TIME

The approximate amount of required transmission time can be calculated by the method given here. Use the approximate time as a standard when designing the system.

6.1 TRANSMISSION TIME FOR LINK BETWEEN PCs

6.1.1 Transmission Delay

(1) Transmission Time

The frame format of the link data transmitted onto the link line is as follows.

HEADER	DATA	FCS	EOF
--------	------	-----	-----

Header: 32 bytes

Data: 1 to 512 bytes

FCS (Frame Check Sequence): 2 bytes

EOF (End Of Frame): 1 byte

Therefore, the fixed part of the frame is 35 bytes. The transmission time is calculated as follows:

$$T_{\text{snd}} [\mu\text{s}] = (35 + N_d) \times 8 \div f$$

N_d : Number of data [bytes]

f : Transmission rate [Mbps]

The number of data is the number of data allocated in the WMAP of each station.

(Example)

When allocated (WMAP);

Discrete: 32 points

Register: 32 registers

The number of data is 68 bytes.

The transmission time for this allocation is as follows:

Transmission rate	4 Mbps	2 Mbps	1 Mbps	0.5 Mbps
Transmission time	0.21 ms	0.41 ms	0.82 ms	1.65 ms

(2) Transmission Processing Time

The transmission processing time is the time required after acquiring the token for link data transmission processing, when there are transmission data. The time is about 1 ms per station, independent of the transmission data amount and transmission rate.

(3) Token Rotation Time

The token moves around the transmission path, and transmission is enabled in each station only when the token is held.

The processing time for each station to acquire the token and to pass the token to the next station is approximately 1 ms. The token transmission time is also included in this time. (Fixed, regardless of the transmission rate)

Therefore, the maximum time T_g from the release of the token at a station to the next acquirement of the token is calculated as;

$$T_g[\text{ms}] = N_s \times 1 + T_s + \Sigma T_{\text{snd}}$$

N_s : Number of stations

T_s : Transmission processing time of other station $\{ = (N_s - 1) \times 1 \}$

ΣT_{snd} : Sum of data transmission time at other station

6.1.2 Transmission Time

Fig. 6.1 shows the transmission timing when there are two stations. The logic is also the same with more stations.

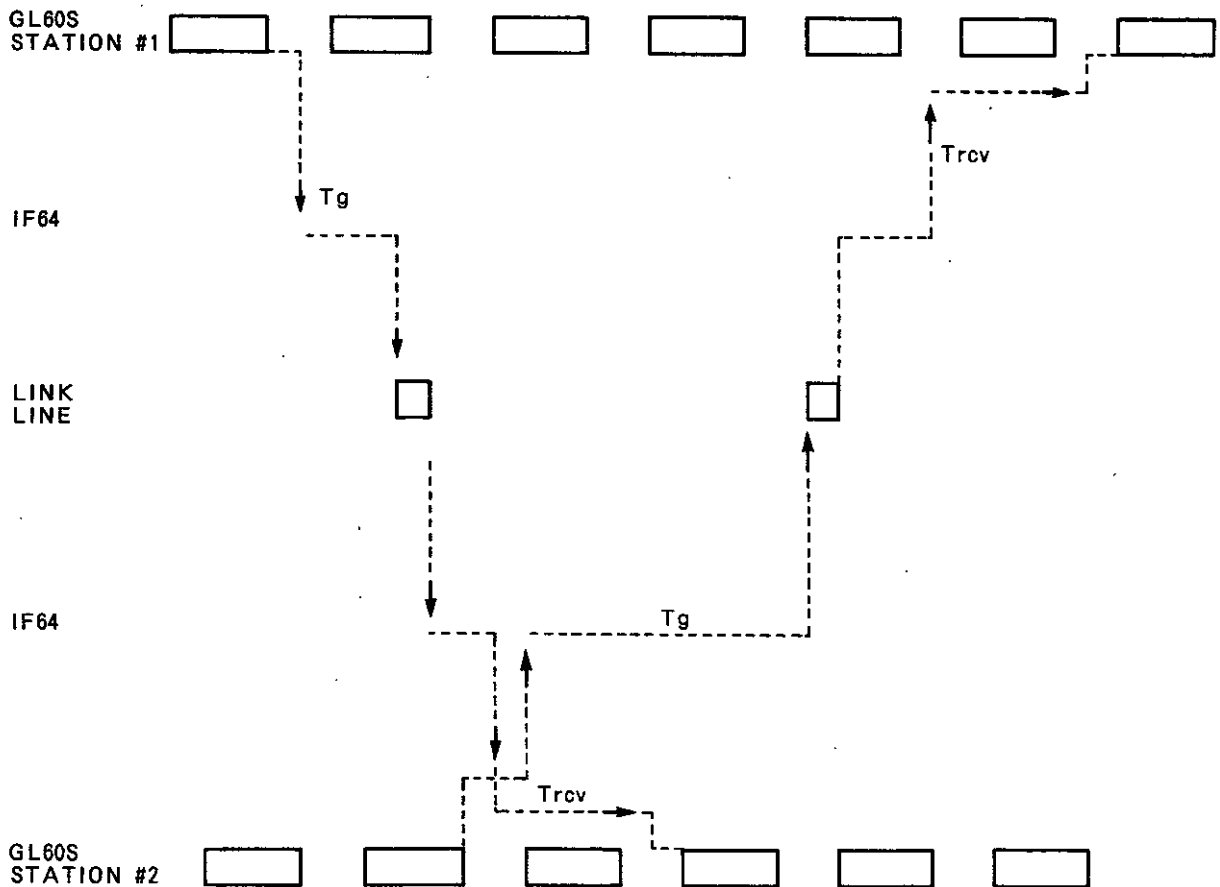

Fig. 6.1 Timing of Transmission

6.1.2 Transmission Time (Cont'd)

The time of the link data to reach the CPU of station 2 from the CPU of station 1 is given by the sum of the following:

- Token acquirement time (T_g)
- Station 1 link data transmission time (T_{snd})
- Reception processing time (T_{rcv})

The above T_{rcv} depends on the scan time and timing of the GL60S. The maximum value is;

$$T_{rcv} = 2 \times \text{scan period (Applied to only 30 ms or more)}$$

When processing the received link data by the ladder and sending the result to other stations or outputting the result, add one scan period as the ladder processing time.

(Example of calculation)

Conditions:

Number of stations = 4

Number of link data = 68 bytes/station

- Discrete: 32 points
- Register: 32 registers

Transmission rate = 4 Mbps

Scan period = 30 ms (Scan period is the same for all stations)

Transmission data: Prepared for all stations

No PP transmission

(1) Station 1 → Station 2 Reach Time

$$T_g = 7.63 \text{ [ms]}$$

$$T_{snd} = 0.21 \text{ [ms]}$$

$$T_{rcv} = 60 \text{ [ms]}$$

Therefore, the maximum time is 67.84 ms.

(2) Station 1 → Station 2 → Station 1 Reach Time

(a) Station 1 → Station 2 : 67.84 ms

(b) Station 2 → Station 1 :

The sum of; $T_g = 7.63$ [ms]

$T_{snd} = 0.21$ [ms]

$T_{rcv} = 60$ [ms]

Plus

the 1 scan period (30 ms) at station 2.

Therefore, the time is 97.84 ms.

The total time is (a) plus (b), which is approximately 165.7 ms.

6.2 TRANSMISSION TIME FROM PP PORT

6.2.1 Transmission Delay

(1) Transmission Time on Link Line

The frame format of the message data transmitted onto the link line is as follows.

HEADER	DATA	FCS	EOF
--------	------	-----	-----

Header: 18 bytes

Data: 7 to 255 bytes

FCS (Frame Check Sequence): 2 bytes

EOF (End Of Frame): 1 byte

Therefore, the fixed part of the frame is 21 bytes. The transmission time is calculated as follows.

$$T_{snd} [\mu s] = (21 + N_{md}) \times 8 \div f$$

N_{md} : Number of data [bytes]

f : Transmission rate [Mbps]

The number of data depends on the transmission message from the device connected to the PP port or the response message from the destination station.

6.2.1 Transmission Delay (Cont'd)

(2) Transmission Time on RS-232C Line

The time for transmission between the PP port and the connected device (PP, etc.) is calculated by the following expression.

$$T_{232c} = \frac{Nmd \times 11 \times 1000}{9600} \text{ (ms)}$$

Nmd: Number of data in (1)

(3) Processing Time of Transmission to Link Line

The time required for transmitting the data received from the PP port or the response message from the CPU to the link line. This time is the time required for the transmission processing after acquiring the token. The time is about 0.5 ms, independent of the transmission data amount and transmission rate.

(4) Token Rotation Time

As with the link data transmission, the station can transmit the message data to the link line, only when the token is held.

The processing time for each station to acquire the token and to pass the token to the next station is approximately 1 ms. The token transmission time is also included in this time. (Fixed, regardless of the transmission rate)

Therefore, the maximum time T_g from the release of the token at a station to the next acquirement of the token is calculated as;

$$T_g[\text{ms}] = N_s \times 1 + T_s + \Sigma T_{snd}$$

N_s : Number of stations

T_s : Transmission processing time of other station

$$\{= (N_s - 1) \times 1 + N_f \times 0.5\}$$

ΣT_{snd} : Sum of data transmission time at other station
(both link data and message data)

N_f : Number of message data frames at other station

(5) Token Holding Time

The token holding time is 10 ms. The data can be transmitted onto the link line after the token is acquired for as long as this token holding time. The token is passed on to the next station if there is no other transmission data, even before the token holding time has elapsed.

NOTE

The transmission processing time, token rotation time, token holding time are not individual for each of link data and message data. They are mutually related.

6.2.2 Transmission Time

The transmission time required for communication from the PP port to a station is the sum of the following.

- ① Command transmission time to the PP port
- ② Token rotation time
- ③ Command transmission time to the link line
- ④ Reception processing time at the destination station
- ⑤ Token rotation time
- ⑥ Response transmission time to the link line
- ⑦ Response transmission time from the PP port

The following is an example of calculation of the required transmission time.

(Example of calculation)

The following example is a calculation of the time required for reading 125 holding registers until the response is returned. The link data are also transmitted here.

Conditions:

Number of stations = 4

Number of link data = 68 bytes/station

- Discrete: 32 points
- Register: 32 registers

Transmission speed = 4 Mbps

Scan period = 30 ms (Scan period is the same for all stations)

Transmission data: Prepared for all stations

6.2.2 Transmission Time (Cont'd)

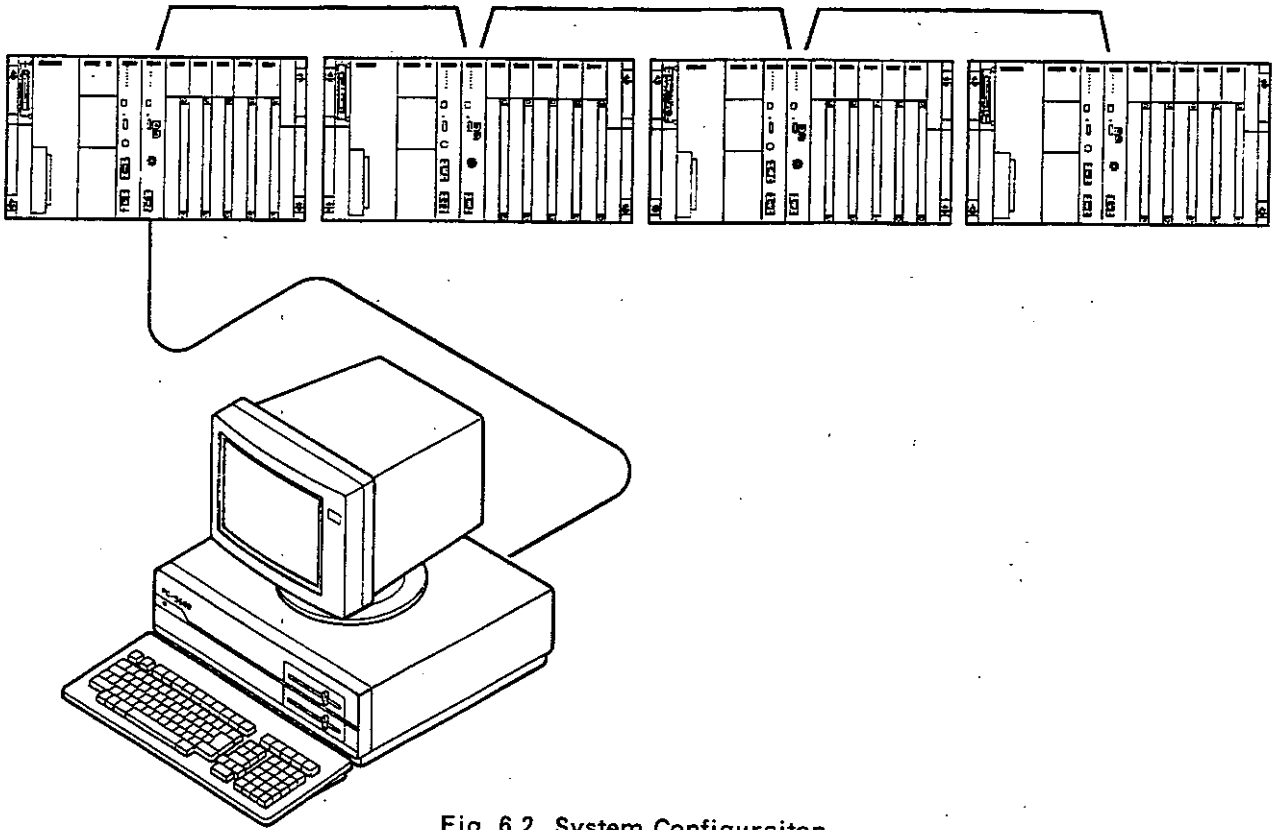

Fig. 6.2 System Configuraiton

① Command transmission time to the PP port

The number of command characters is 8 bytes. Therefore, the transmission time is;

$$\frac{8 \times 11 \times 1000}{9600} \approx 9.17 \text{ ms}$$

② Token rotation time

As all stations transmit link data, the token rotation time is;

$$4 \times 1 + 3 \times 1 + 3 \times 0.21 = 7.63 \text{ ms}$$

③ Command transmission time to the link line

The transmission time of the command to the link line is the sum of the link data transmission processing time and transmission time, plus the message data (command) transmission processing time and transmission time.

- Link data transmission processing time: 1 ms
- Link data transmission time: 0.21 ms
- Command transmission processing time: 0.5 ms
- Command transmission time:
 $(21 + 8) \times 8 \div 4 = 58 \text{ } [\mu\text{s}]$

Therefore, the command transmission time is;
Approximately 1.77 ms.

NOTE

This value indicates that all data can be transmitted within the token holding time.

④ Reception processing time at the destination station

Maximum 2 scan periods are required. Therefore;

$$2 \times \text{Scan period} + \text{Command processing time} = 2 \times 30 + 2 = 62 \text{ [ms]}$$

NOTE

There are some commands that are divided into 2 scans. In this case, add one more scan period and command processing time = 2 ms.

⑤ Token rotation time

As in ②, the token rotation time is;

$$4 \times 1 + 3 \times 1 + 3 \times 0.21 = 7.63 \text{ [ms]}$$

⑥ Response transmission time to the link line

The transmission time of the response to the link line is the sum of the link data transmission processing time and transmission time, plus the message data (response) transmission processing time and transmission time.

- Link data transmission processing time: 1 ms
- Link data transmission time: 0.21 ms
- Response transmission processing time: 0.5 ms
- As the number of response characters is 255 bytes, the response transmission time is;
$$(21 + 255) \times 8 \div 4 = 552 \text{ [\mu s]}$$

Therefore, the response transmission time is;
Approximately 2.26 ms.

NOTE

This value indicates that all data can be transmitted within the token holding time.

6.2.2 Transmission Time (Cont'd)

⑦ Response transmission time from the PP port

The number of response characters is 255 bytes. Therefore, the transmission time is;

$$\frac{255 \times 11 \times 1000}{9600} \approx 292.19 \text{ [ms]}$$

The grand total of ① to ⑦ is 382.65.ms, which is the target communication time (maximum value.)

6.2.3 Influence of Message Transmission

The following four factors prolong the transmission period of the link data when PP, etc. are connected to the PP ports.

- Transmission processing time of the command to the link line (0.5 ms)
- Transmission time of the command to the link line
- Transmission processing time of the response to the link line (0.5 ms)
- Transmission time of the response to the link line

In the example of par. 6.2.2, the link data transmission period for transmission of the message data is prolonged for:

- Approx. 0.56 ms (influence of command transmission)
- Approx. 1.05 ms (influence of response transmission)

Each transmission of the command and the response is not on the same transmission cycle, which is individually influenced. When multiple PPs, etc. are connected to the PP ports, each value is accumulated on the transmission period.

7. MOUNTING

7.1 ENVIRONMENTAL CONDITIONS

The environmental conditions for installation of the GL60S follows the general specifications and the environmental conditions of each module. In general, the following environments are to be avoided.

- Where the ambient temperature exceeds the range of 0 to 55°C.
- Where the humidity exceeds the range of 30 to 90%RH.
- Where condensation occurs by rapid change of temperature.
- Where vibration or shock is directly applied on the main body.
- Near inflammable or corrosive gas.
- Where exposed to dust, oil mist, conductive powder, salt, organic solvents, etc.
- Where strong electric fields or strong magnetic fields are generated.
- Where exposed to direct sunlight.

Also take care of the wiring path of the coaxial cable that interconnects the IF64.

7.2 WIRING

7.2.1 Connection

The wiring in the panel and between panels must be considered. The wiring must conform to the specifications of the "GL60S Remote I/O User's Manual."

Fig. 7.1 shows the connection between the IF64 and the conversion adapter (T-0298). Connect the branching T-type connector with the BNC connector (LINE) on the front of the module. Connect one end of the coaxial cable with BNC connector at both ends to the conversion adapter, and the other to the right side (or left side) of the T-type connector.

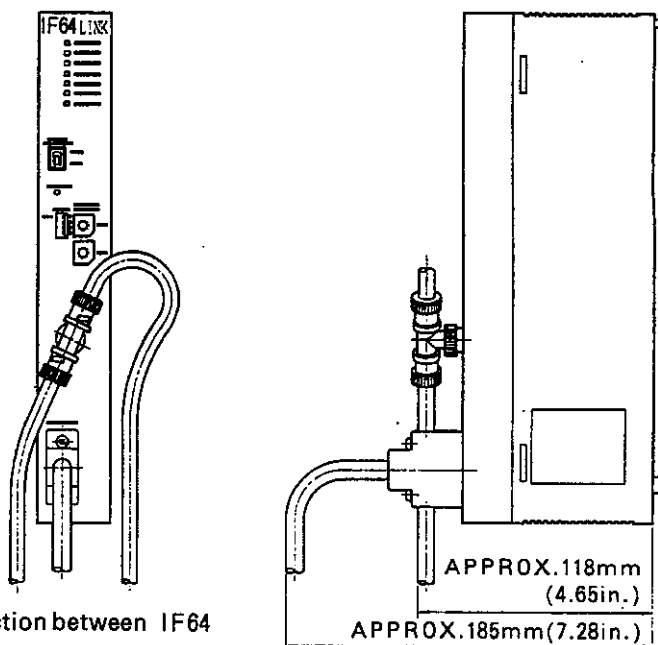

Fig. 7.1(a) Connection between IF64 and Conversion Adapter

7.2.1 Connection (Cont'd)

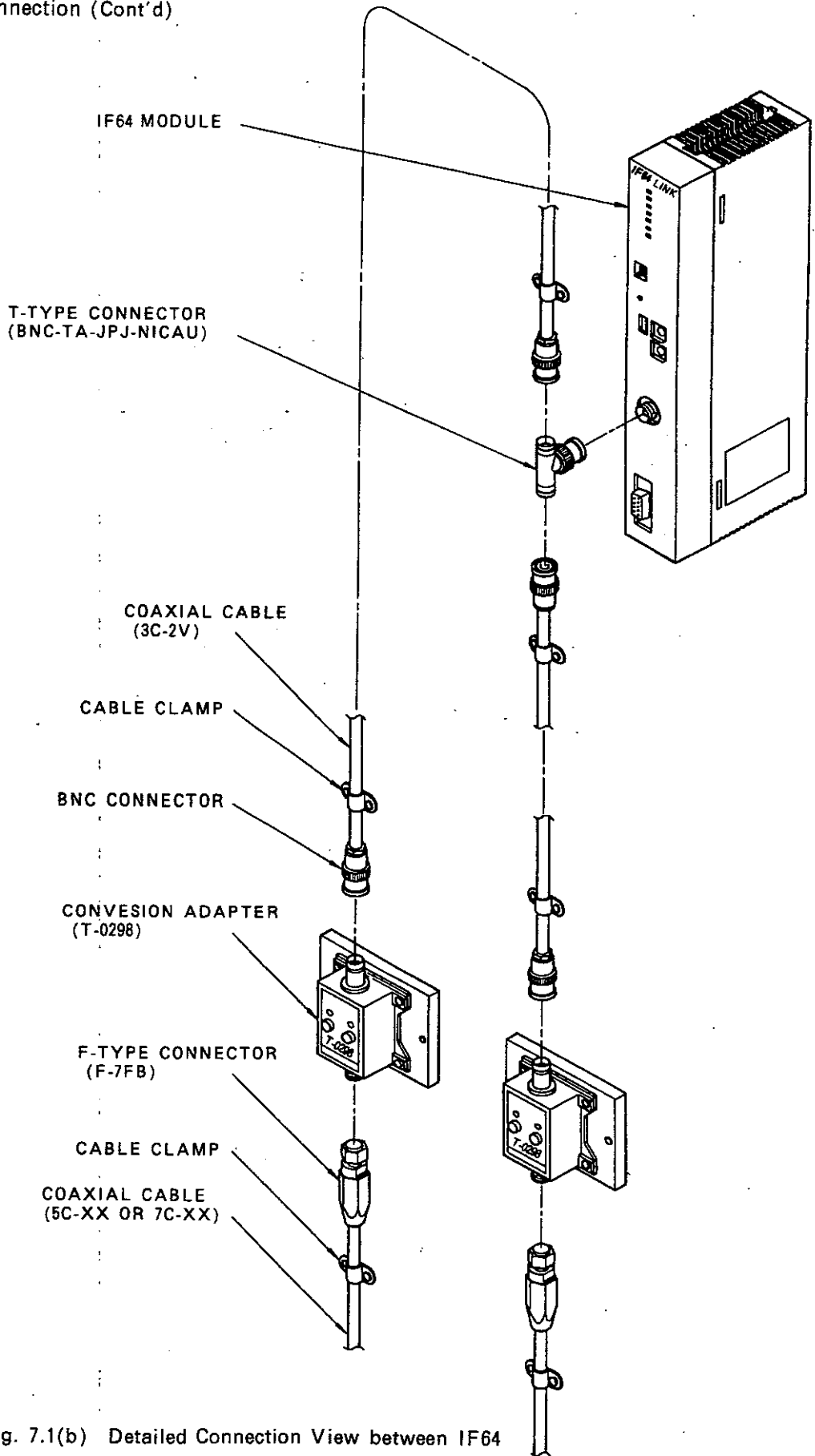

Fig. 7.1(b) Detailed Connection View between IF64 and Connection Adapter

Figs. 7.2 and 7.3 show the inter-connections of the IF64s.

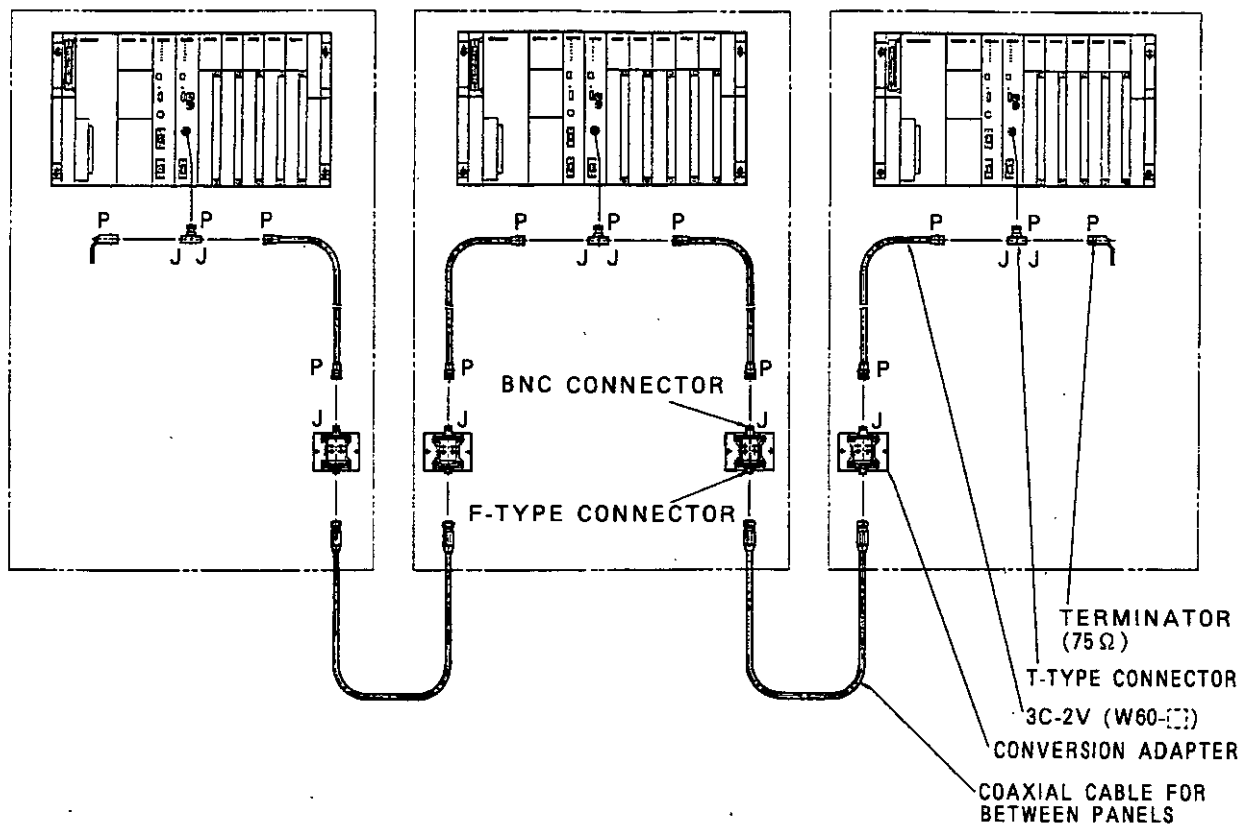

Fig. 7.2 Inter-connection of IF64s (Panel-to-Panel)

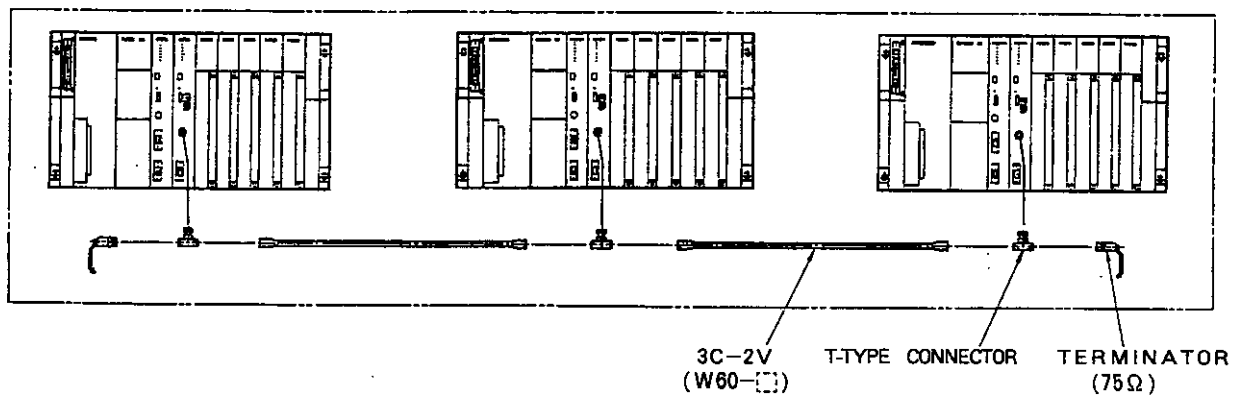

Fig. 7.3 Inter-connection of IF64s (In-panel)

8. INITIALIZING SYSTEM

Transmission/reception of the link data is executed automatically as the initial process after power has been applied. See par. 4.2 for details on the allocation. The allocation data are stored in the backup memory of the CPU. Therefore, once set, there is no need to reset the data again, unless change becomes necessary.

There is no restriction for the power supply sequence. Any power supply sequence allows to start the link data communication. This system performs transmission by the token passing method, as will be mentioned in Section 9. Communication of link data starts between stations where power is supplied.

9. TRANSMISSION CONTROL PROCEDURE

9.1 TOKEN PASS

The transmission mechanism of the PC link is of the token passing method. The station that acquired the token (right to transmit) is allowed to transmit data. When a station has completed transmitting data frames it passes the token to the next station. The token will be passed station to station in station-address order, ascending numerically except that the station with highest address will pass the token to the station with the lowest address, in order to close the logical ring. See Fig. 9.1.

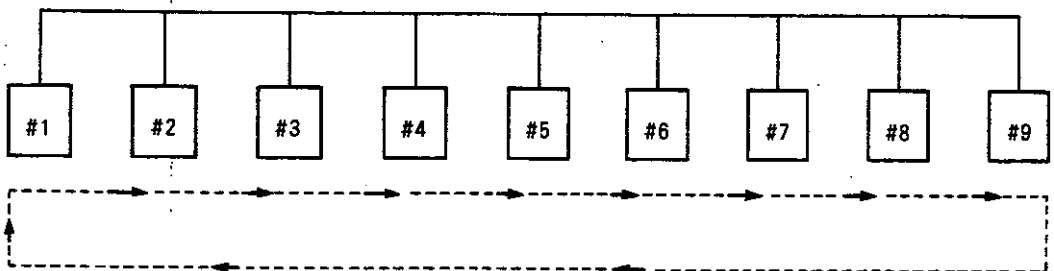

Fig. 9.1 Token Pass

The physical arrangement of the station need not be the sequence of the station number.

- (1) If a station has transmission data, it can transmit the data during the token holding time, each time it receives the token. The token holding time of the IF64 is 10 ms.
- (2) If the station has no transmission data, it passes the token to the next station.

9.2 ERROR PROCESSING

(1) Removal of Failure Station

As shown in Fig. 9.2, the token is not passed to stations that cannot perform transmission because of failure, or stations where power is not supplied. These stations are removed from the logical ring. The logical ring is re-established by the remaining stations.

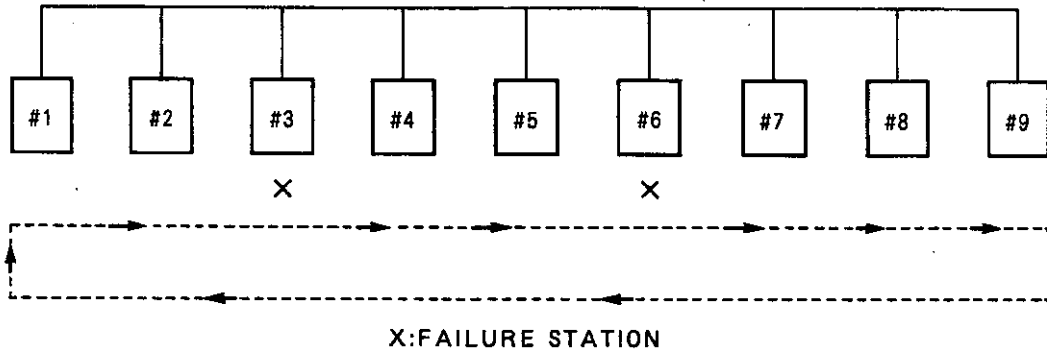

Fig. 9.2 Removal of Failure Station

(2) Disconnection of Transmission Line

The token is passed among stations connected by the same transmission line in ascending order of the station number. Therefore, as shown in Fig. 9.3, there will be three tokens if the transmission line is disconnected at two positions.

In such cases, the terminator will be missing, and reflection causes the transmission to become fault.

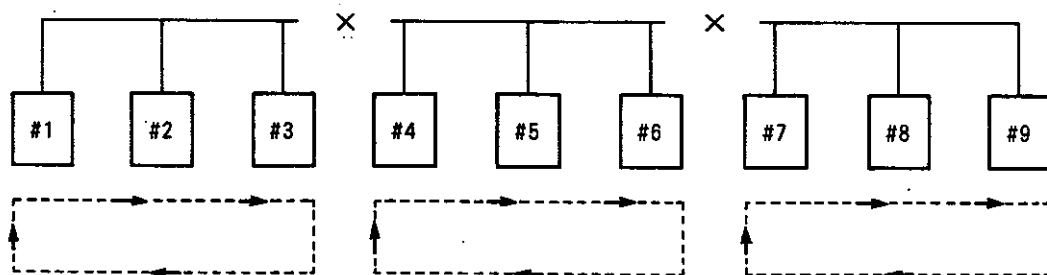

Fig. 9.3 Disconnection of Transmission Line

9.2 ERROR PROCESSING (Cont'd)

(3) Entering Logical Ring

When all station (32 stations) are not connected to the transmission line, a periodical check (every second) checks for new stations. This function maintains the logical ring for the token pass. When a new station enters the ring, the logical ring is re-established in the ascending order of the station numbers at most of 8 seconds.

Therefore, a station is correctly connected to the transmission path whenever power is supplied. Stations that recovered from failure also automatically enter to the logical ring.

(4) Status

All IF64 status data are stored in the GL60S system status area. The contents can be referred by the "STAT instruction" in the ladder.

(a) Machine status

Indicates if the mounted IF64 module has error.

Fig. 9.4 Machine Status

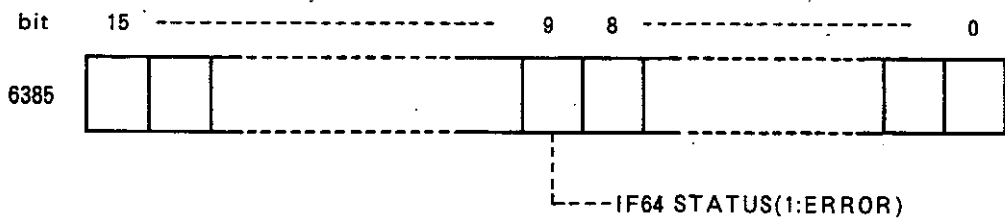

(b) PC link status

The IF64 module status is set and stored in "638A." The following are the status codes. If any error status code is set, the bit 9 of the above machine status is set to 1.

Table 9.1 Status Code

Status Code	Status
XX00H	Normal
XX01H	ROM error
XX02H	RAM error
XX03H	Common memory error
XX08H	Link data communication stop
XX0FH	IF64 watchdog timer error

Link data communication stop (code XX08H) does not mean error status code.

NOTE

Higher-order byte of the PC link status is used to monitor a DIP switch, a memory protect switch, etc.

(c) Station status

The storage area and bit allocation of the status of each station are as shown in Fig. 9.5. This status reflects the communication status.

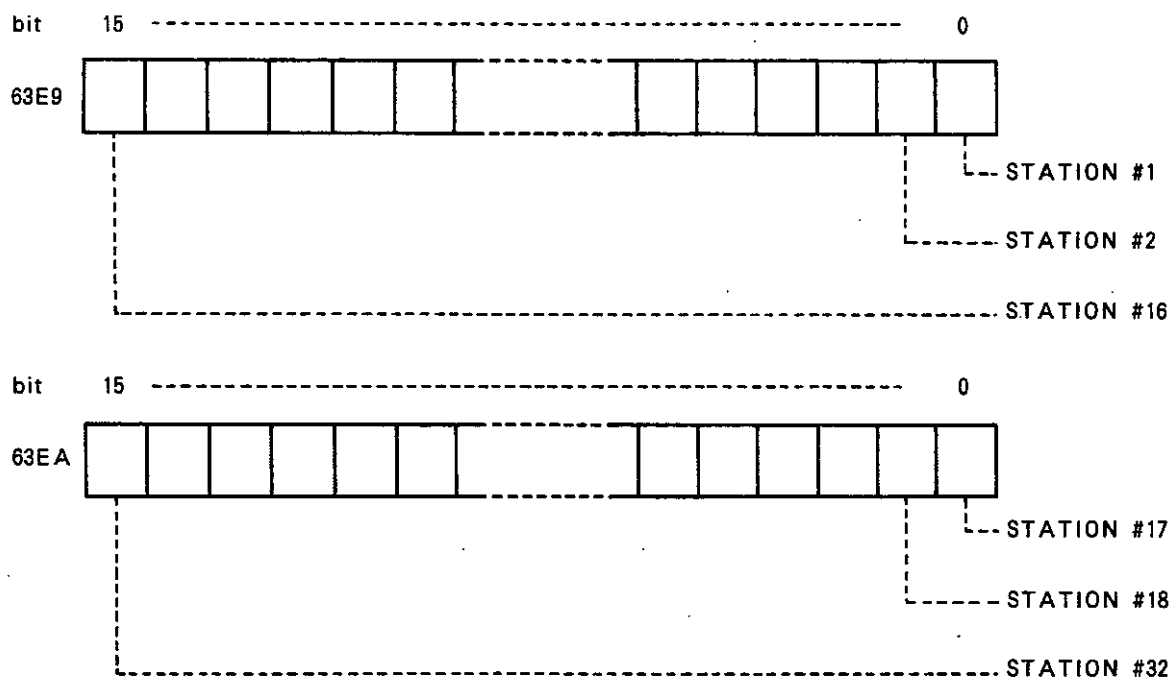

Fig. 9.5 Link Station Status

The IF64 station status is updated every scan.

- 1: Connected to the link line
- 0: Failure station

9.3 SCAN AND TRANSMISSION OF LINK DATA

As shown in Fig. 9.6, the link data are not transmitted every reception of the token, but on acquirement of the token immediately after the link data from the CPU is updated.

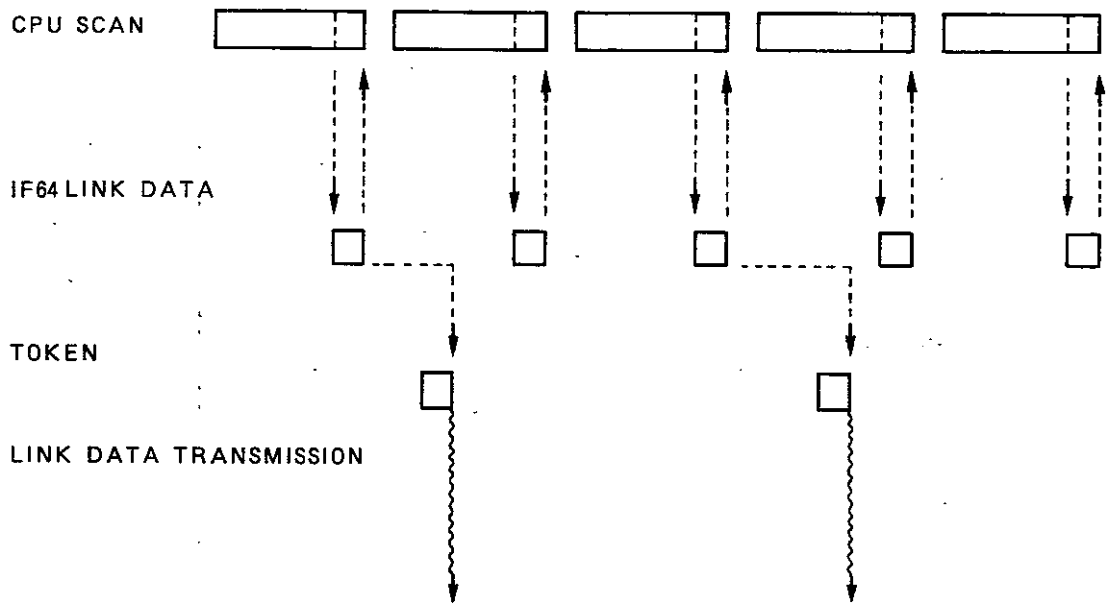

(a) Where Token Rotation Time Longer than Scan Period

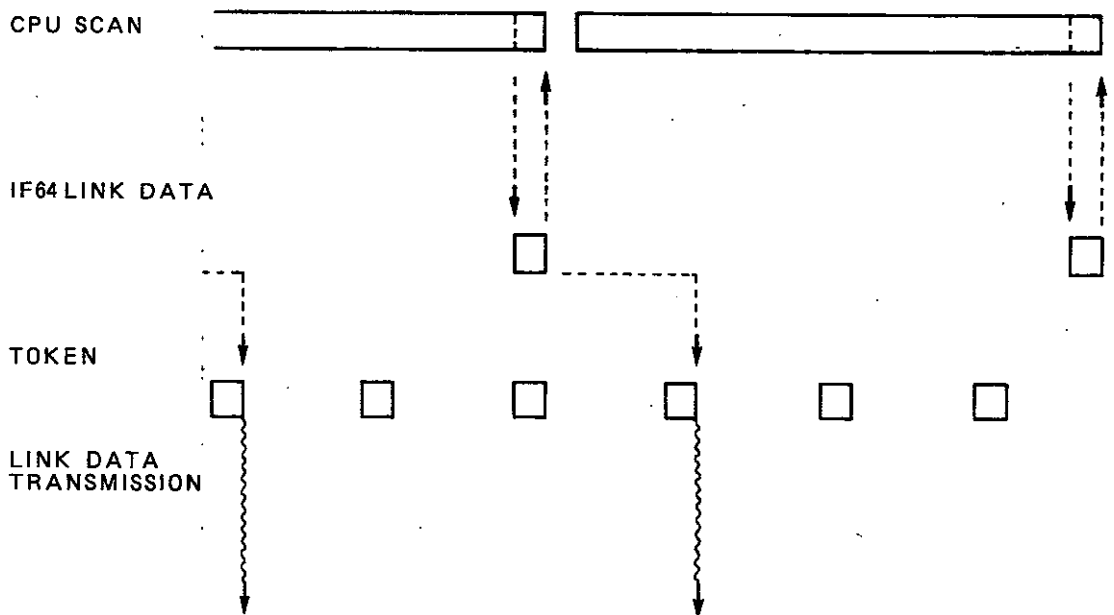

(b) Where Token Rotation Time Shorter than Scan Period

Fig. 9.6 Timing of Link Data Transmission

NOTE

In two-level scan, the link data are updated in low-speed scan level.

10. MAINTENANCE

The checking flow for link module is shown below. Use it in maintenance.

NOTE

The symbols used in the flow chart have the following meanings:

- ▭ : Action
- : Terminal or comment
- ◇ : Decision

■ Link Module Check

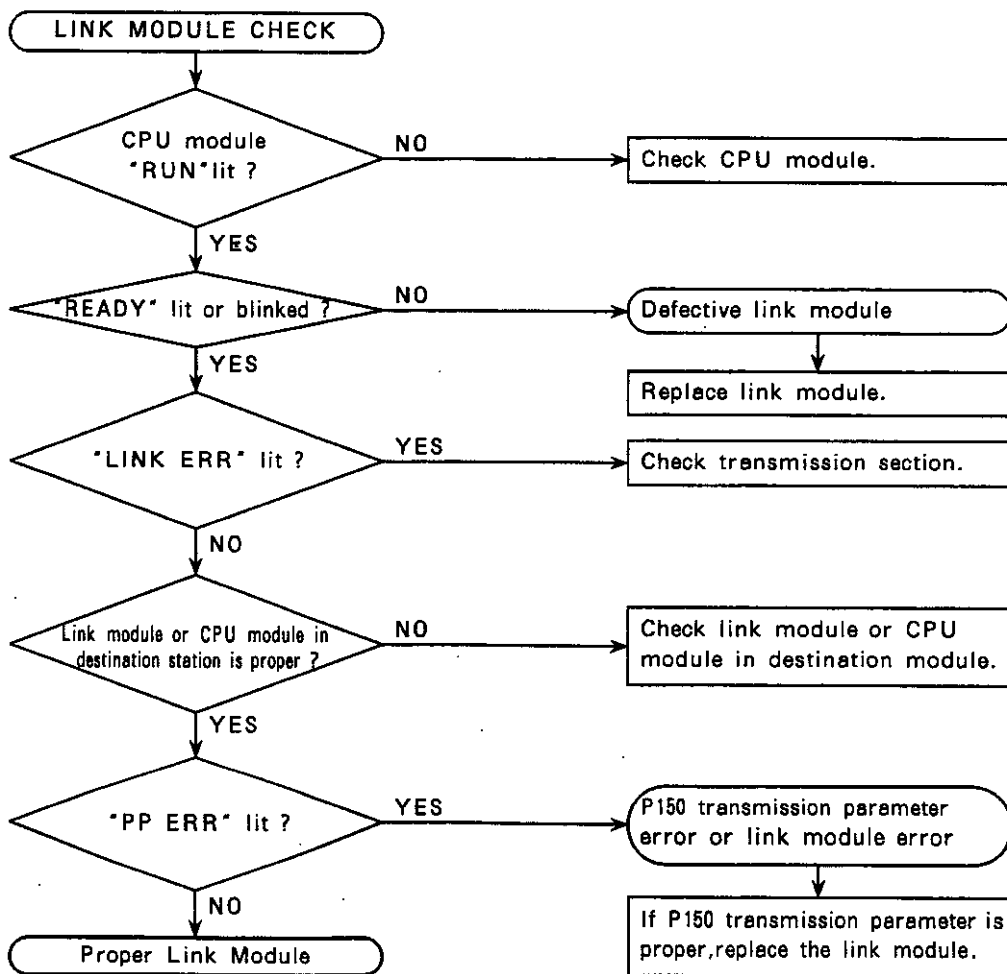

APPENDIX A

DIMENSIONS in mm (inches)

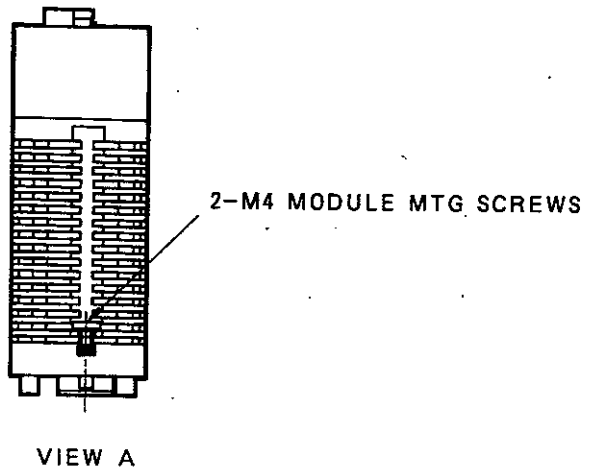
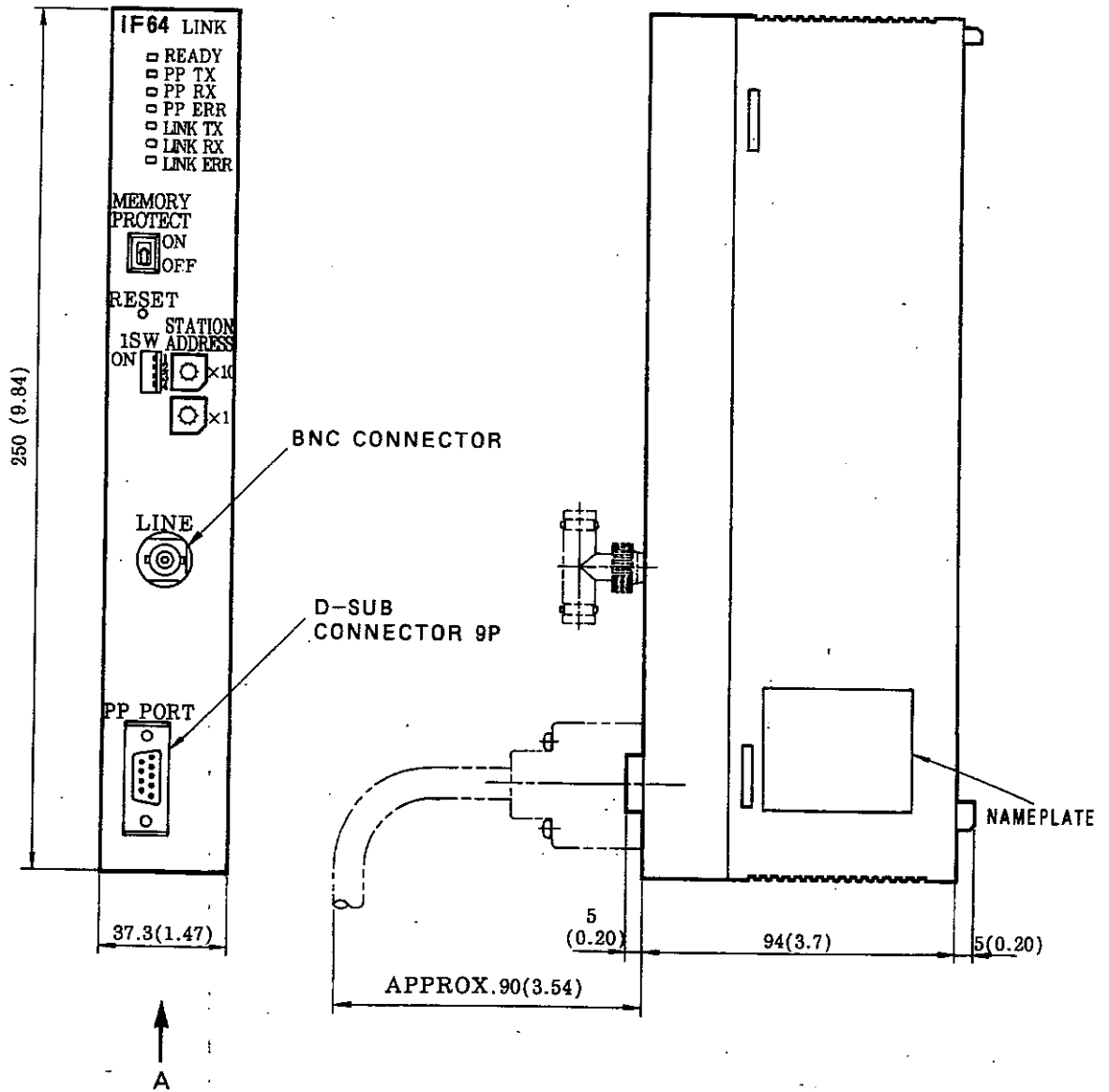

APPENDIX B

MEMOBUS COMMAND LIST

Function Code		Function	Max. No. of Bytes Used in 1 Scan	Max. No. of Bytes Processed in 1 Scan	In Unit of Byte			
Hex.	Decimal				Instruction Message		Response Message	
					Min.	Max.	Min.	Max.
1	1	Reading out specified coil state	2000	2000	8	8	6	255
2	2	Reading out specified input relay state	2000	2000	8	8	6	255
3	3	Reading out holding register contents	125	125	8	8	7	255
4	4	Reading out input register contents	125	125	8	8	7	255
5	5	Changing state of specified single coil	1	1 (in 2 scans)	8	8	8	8
6	6	Writing in specified single holding register	1	1	8	8	8	8
7	7	Reading out particular coil state	8	8	4	4	5	5
8	8	Loopback test	—	—	8	8	8	8
F	15	Changing multi-coil states	800	800 (in 2 scans)	10	109	8	8
10	16	Writing in multi-holding registers	100	100	11	209	8	8
12	18	Reading out specified link relay state	1024	1024	8	8	6	133
13	19	Reading out constant register contents	125	125	8	8	7	255
14	20	Reading out step-elapsed time register contents	125	125	8	8	7	255
15	21	Reading out link register contents	125	125	8	8	7	255
16	22	Reading out extended register contents	125	125	8	8	7	255
17	23	Reading out step state	512	512	8	8	6	69
19	25	Changing specified link relay state	1	1 (in 2 scans)	8	8	8	8
1A	26	Writing in specified constant register	1	1	8	8	8	8
1B	27	Writing in specified link register	1	1	8	8	8	8
1C	28	Writing in specified extended register	1	1	8	8	8	8
1D	29	Changing multi-link relay state	1024	1024 (in 2 scans)	10	137	8	8
1E	30	Writing in multi-constant register	123	123	11	255	8	8
1F	31	Writing in multi-link register	123	123	11	255	8	8
20	32	Writing in multi-extended register	123	123	11	255	8	8

Note: All message lengths are represented in RTU mode.

PC LINK MODULE USER'S MANUAL

TOKYO OFFICE

New Pier Takeshiba South Tower, 1-16-1, Kaigan, Minatoku, Tokyo 105-6891 Japan
Phone 81-3-5402-4511 Fax 81-3-5402-4580

YASKAWA ELECTRIC AMERICA, INC.

2121 Norman Drive South, Waukegan, IL 60085, U.S.A.
Phone 1-847-887-7000 Fax 1-847-887-7370

MOTOMAN INC. HEADQUARTERS

805 Liberty Lane West Carrollton, OH 45449, U.S.A.
Phone 1-937-847-6200 Fax 1-937-847-6277

YASKAWA ELÉTRICO DO BRASIL COMÉRCIO LTDA.

Avenida Fagundes Filho, 620 Bairro Saude-Sao Paulo-SP, Brazil CEP: 04304-000
Phone 55-11-5071-2552 Fax 55-11-5581-8795

YASKAWA ELECTRIC EUROPE GmbH

Am Kronberger Hang 2, 65824 Schwalbach, Germany
Phone 49-6196-569-300 Fax 49-6196-888-301

Motoman Robotics Europe AB

Box 504 S38525 Torås, Sweden
Phone 46-486-48800 Fax 46-486-41410

Motoman Robotec GmbH

Kammerfeldstraße 1, 85391 Allershausen, Germany
Phone 49-8166-900 Fax 49-8166-9039

YASKAWA ELECTRIC UK LTD.

1 Hunt Hill Orchardton Woods Cumbernauld, G68 9LF, United Kingdom
Phone 44-1236-735000 Fax 44-1236-458182

YASKAWA ELECTRIC KOREA CORPORATION

Kpa Bldg #1201, 35-4 Youido-dong, Yeongdeungpo-Ku, Seoul 150-010, Korea
Phone 82-2-784-7844 Fax 82-2-784-8495

YASKAWA ELECTRIC (SINGAPORE) PTE. LTD.

151 Lorong Chuan, #04-01, New Tech Park Singapore 556741, Singapore
Phone 65-282-3003 Fax 65-289-3003

YASKAWA ELECTRIC (SHANGHAI) CO., LTD.

4F No. 18 Aona Road, Waigaoqiao Free Trade Zone, Pudong New Area, Shanghai 200131, China
Phone 86-21-5866-3470 Fax 86-21-5866-3869

YATEC ENGINEERING CORPORATION

Shen Hsiang Tang Sung Chiang Building 10F 146 Sung Chiang Road, Taipei, Taiwan
Phone 886-2-2563-0010 Fax 886-2-2567-4677

YASKAWA ELECTRIC (HK) COMPANY LIMITED

Rm. 2909-10, Hong Kong Plaza, 186-191 Connaught Road West, Hong Kong
Phone 852-2803-2385 Fax 852-2547-5773

BEIJING OFFICE

Room No. 301 Office Building of Beijing International Club, 21
Jianguomenwai Avenue, Beijing 100020, China
Phone 86-10-6532-1850 Fax 86-10-6532-1851

TAIPEI OFFICE

Shen Hsiang Tang Sung Chiang Building 10F 146 Sung Chiang Road, Taipei, Taiwan
Phone 886-2-2563-0010 Fax 886-2-2567-4677

SHANGHAI YASKAWA-TONGJI M & E CO., LTD.

27 Hui He Road Shanghai China 200437
Phone 86-21-6531-4242 Fax 86-21-6553-6060

BEIJING YASKAWA BEIKE AUTOMATION ENGINEERING CO., LTD.

30 Xue Yuan Road, Haidian, Beijing P.R. China Post Code: 100083
Phone 86-10-6233-2782 Fax 86-10-6232-1536

SHOUGANG MOTOMAN ROBOT CO., LTD.

7, Yongchang-North Street, Beijing Economic Technological Investment & Development Area,
Beijing 100076, P.R. China
Phone 86-10-6788-0551 Fax 86-10-6788-2878



YASKAWA ELECTRIC CORPORATION