

DC Power Input Σ -II Series SGM□J/SGDJ USER'S MANUAL

AC Servodrives

SGMMJ/SGMAJ Servomotor
SGDJ SERVOPACK



YASKAWA

MANUAL NO. SIE-S800-38C

Copyright © 2000 YASKAWA ELECTRIC CORPORATION

All rights reserved. No part of this publication may be reproduced, stored in a retrieval system, or transmitted, in any form, or by any means, mechanical, electronic, photocopying, recording, or otherwise, without the prior written permission of Yaskawa. No patent liability is assumed with respect to the use of the information contained herein. Moreover, because Yaskawa is constantly striving to improve its high-quality products, the information contained in this manual is subject to change without notice. Every precaution has been taken in the preparation of this manual. Nevertheless, Yaskawa assumes no responsibility for errors or omissions. Neither is any liability assumed for damages resulting from the use of the information contained in this publication.

About this Manual

■ Intended Audience

This manual is intended for the following users.

- Those selecting Σ -II Series servodrives or peripheral devices for Σ -II Series servodrives.
- Those wanting to know about the ratings and characteristics of Σ -II Series servodrives.
- Those designing Σ -II Series servodrive systems.
- Those installing or wiring Σ -II Series servodrives.
- Those performing trial operation or adjustments of Σ -II Series servodrives.
- Those maintaining or inspecting Σ -II Series servodrives.

■ Description of Technical Terms

The terms in this manual are defined as follows:

- Servomotor or motor = DC power input Σ -II Series SGMMJ and SGMAJ servomotor.
- SERVOPACK = DC power input Σ -II Series SGDJ amplifier.
- Servodrive = A set including a servomotor and servo amplifier.
- Servo System = A servo control system that includes the combination of a servodrive with a host computer and peripheral devices.
- Parameter number = Numbers that the user inputs toward the SERVOPACK.

■ Indication of Reverse Signals

In this manual, the names of reverse signals (ones that are valid when low) are written with a forward slash (/) before the signal name, as shown in the following example:

- $\overline{\text{S-ON}}$ = /S-ON
- $\overline{\text{P-CON}}$ = /P-CON

■ Quick access to your required information

Read the chapters marked with ✓ to get the information required for your purpose.

Chapter	SERVOPACKs, Servomotors, and Peripheral Devices	Ratings and Characteristics	System Design	Panel Configuration and Wiring	Trial Operation and Servo Adjustment	Inspection and Maintenance
Chapter 1 Outline	✓					
Chapter 2 Selections	✓					
Chapter 3 Specifications and Dimensional Drawings	✓	✓	✓	✓		
Chapter 4 SERVOPACK Specifications and Dimensional Drawings	✓	✓	✓	✓		
Chapter 5 Specifications and Dimensional Drawings of Cables and Peripheral Devices	✓	✓	✓	✓		
Chapter 6 Wiring			✓	✓	✓	
Chapter 7 Digital Operator			✓		✓	
Chapter 8 Operation					✓	
Chapter 9 Adjustments						✓
Chapter 10 Inspection, Maintenance, and Troubleshooting	✓		✓		✓	✓

■ Visual Aids

The following aids are used to indicate certain types of information for easier reference.



- Indicates important information that should be memorized, including precautions such as alarm displays to avoid damaging the devices.



- Indicates supplemental information.



- Indicates application examples.

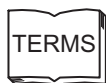

- Indicates definitions of difficult terms or terms that have not been previously explained in this manual.

Related Manuals

Refer to the following manuals as required.

Manual Name	Manual Number	Contents
Σ -II Series SGM□H/SGDM Digital Operator Operation Manual	TOE-S800-34	Provides detailed information on the operating method of JUSP-OP02A-2 type Digital Operator (option device).
Σ -II Series SERVOPACKs Personal Computer Monitoring Software Operation Manual	SIE-S800-35	Describes the using and the operating methods on software that changes the local personal computer into the monitor equipment for the Σ -II Series servomotor.

Safety Information

The following conventions are used to indicate precautions in this manual. Failure to heed precautions provided in this manual can result in serious or possibly even fatal injury or damage to the products or to related equipment and systems.



Indicates precautions that, if not heeded, could possibly result in loss of life or serious injury.



Indicates precautions that, if not heeded, could result in relatively serious or minor injury, damage to the product, or faulty operation.

In some situations, the precautions indicated could have serious consequences if not heeded.



Indicates prohibited actions that must not be performed. For example, this symbol would be used as follows to indicate that fire is prohibited: .



Indicates compulsory actions that must be performed. For example, this symbol would be used as follows to indicate that grounding is compulsory: .

The warning symbols for ISO and JIS standards are different, as shown below.

ISO	JIS
	



The ISO symbol is used in this manual.

Both of these symbols appear on warning labels on Yaskawa products. Please abide by these warning labels regardless of which symbol is used.

Notes for Safe Operation

Read this manual thoroughly before checking products on delivery, storage and transportation, installation, wiring, operation and inspection, and disposal of the AC servodrive.

WARNING

- Never touch any rotating motor parts while the motor is running.
Failure to observe this warning may result in injury.
- Before starting operation with a machine connected, make sure that an emergency stop can be applied at any time.
Failure to observe this warning may result in injury.
- Never touch the inside of the SERVOPACKs.
Failure to observe this warning may result in electric shock.
- Do not touch terminals for five minutes after the power is turned OFF.
Residual voltage may cause electric shock.
- Follow the procedures and instructions for trial operation precisely as described in this manual.
Malfunctions that occur after the servomotor is connected to the equipment not only damage the equipment, but may also cause an accident resulting in death or injury.
- The multiturn limit value must be changed only for special applications.
Changing it inappropriately or unintentionally can be dangerous.
- If the Multiturn Limit Disagreement alarm (A.CC) occurs, check the setting of parameter Pn205 in the SERVOPACK to be sure that it is correct.
If Fn013 is executed when an incorrect value is set in Pn205, an incorrect value will be set in the encoder. The alarm will disappear even if an incorrect value is set, but incorrect positions will be detected, resulting in a dangerous situation where the machine will move to unexpected positions.
- Do not remove the cables and connector items while the power is ON.
Failure to observe this warning may result in electric shock.
- Do not damage, press, exert excessive force or place heavy objects on the cables.
Failure to observe this warning may result in electric shock, stopping operation of the product, or burning.
- Provide an appropriate stopping device on the machine side to ensure safety. A holding brake for a servomotor with brake is not a stopping device for ensuring safety.
Failure to observe this warning may result in injury.
- Do not come close to the machine immediately after resetting momentary power loss to avoid an unexpected restart. Take appropriate measures to ensure safety against an unexpected restart.
Failure to observe this warning may result in injury.
-  Connect the ground terminal to electrical codes (ground resistance: 100 Ω or less).
Improper grounding may result in electric shock or fire.
-  Installation, disassembly, or repair must be performed only by authorized personnel.
Failure to observe this warning may result in electric shock or injury.
-  Do not modify the product.
Failure to observe this warning may result in injury or damage to the product.

■ Checking on Delivery

CAUTION

- Always use the servomotor and SERVOPACK in one of the specified combinations.
Failure to observe this caution may result in fire or malfunction.

■ Storage and Transportation

CAUTION

- Do not store or install the product in the following places.
 - Locations subject to direct sunlight.
 - Locations subject to temperatures outside the range specified in the storage or installation temperature conditions.
 - Locations subject to humidity outside the range specified in the storage or installation humidity conditions.
 - Locations subject to condensation as the result of extreme changes in temperature.
 - Locations subject to corrosive or flammable gases.
 - Locations subject to dust, salts, or iron dust.
 - Locations subject to exposure to water, oil, or chemicals.
 - Locations subject to shock or vibration.Failure to observe this caution may result in fire, electric shock, or damage to the product.
- Do not hold the product by the cables or motor shaft while transporting it.
Failure to observe this caution may result in injury or malfunction.
- Do not place any load exceeding the limit specified on the packing box.
Failure to observe this caution may result in injury or malfunction.

■ Installation

CAUTION

- Never use the products in an environment subject to water, corrosive gases, inflammable gases, or combustibles.
Failure to observe this caution may result in electric shock or fire.
- Do not step on or place a heavy object on the product.
Failure to observe this caution may result in injury.
- Do not cover the inlet or outlet parts and prevent any foreign objects from entering the product.
Failure to observe this caution may cause internal elements to deteriorate resulting in malfunction or fire.
- Be sure to install the product in the correct direction.
Failure to observe this caution may result in malfunction.
- Provide the specified clearances between the SERVOPACK and the control panel or with other devices.
Failure to observe this caution may result in fire or malfunction.
- Do not apply any strong impact.
Failure to observe this caution may result in malfunction.

■ Wiring

CAUTION

- Do not connect a three-phase power supply to the U, V, or W output terminals.
Failure to observe this caution may result in injury or fire.
- Securely connect the power supply terminals and motor output terminals.
Failure to observe this caution may result in fire.
- Do not bundle or run power and signal lines together in the same duct. Keep power and signal lines separated by at least 30 cm (11.81 in).
Failure to observe this caution may result in malfunction.
- Use twisted-pair shielded wires or multi-core twisted pair shielded wires for signal and encoder (PG) feedback lines.
The maximum length is 3 m (118.11 in) for reference input lines and is 20 m (787.40 in) for PG feedback lines.
- Do not touch the power terminals for five minutes after turning power OFF because high voltage may still remain in the SERVOPACK.
Make sure the charge indicator is turned OFF first before starting an inspection.
- Avoid frequently turning power ON and OFF. Do not turn power ON or OFF more than once per minute.
A high charging current flows for 0.2 seconds in the SERVOPACK when power is turned ON. Frequently turning power ON and OFF causes main power devices such as capacitors and fuses to deteriorate, resulting in unexpected problems.
- Observe the following precautions when wiring main circuit terminal blocks.
 - Remove the terminal block from the SERVOPACK prior to wiring.
 - Insert only one wire per terminal on the terminal block.
 - Make sure that the core wire is not electrically shorted to adjacent core wires.
- Install the battery at either the host controller or the SERVOPACK of the encoder.
It is dangerous to install batteries at both simultaneously, because that sets up a loop circuit between the batteries.
- Be sure to wire correctly and securely.
Failure to observe this caution may result in motor overrun, injury, or malfunction.
- Always use the specified power supply voltage.
An incorrect voltage may result in damage to the SERVOPACK and burning.
- Take appropriate measures to ensure that the input power supply is supplied within the specified voltage fluctuation range. Be particularly careful in places where the power supply is unstable.
An incorrect power supply may result in damage to the product.
- Install external breakers or other safety devices against short-circuiting in external wiring.
Failure to observe this caution may result in fire.
- Take appropriate and sufficient countermeasures for each when installing systems in the following locations.
 - Locations subject to static electricity or other forms of noise.
 - Locations subject to strong electromagnetic fields and magnetic fields.
 - Locations subject to possible exposure to radioactivity.
 - Locations close to power supplies including power supply lines.Failure to observe this caution may result in damage to the product.
- Do not reverse the polarity of the battery when connecting it.
Failure to observe this caution may damage the battery or cause it to explode.

■ Operation

CAUTION

- Conduct trial operation on the servomotor alone with the motor shaft disconnected from machine to avoid any unexpected accidents.
Failure to observe this caution may result in injury.
- Before starting operation with a machine connected, change the settings to match the parameters of the machine.
Starting operation without matching the proper settings may cause the machine to run out of control or malfunction.
- Forward run prohibited (P-OT) and reverse run prohibited (N-OT) signals are not effective during zero point search mode using parameter Fn003.
- When using the servomotor for a vertical axis, install the safety devices to prevent workpieces to fall off due to occurrence of alarm or overtravel. Set the servomotor so that it will stop in the zero clamp state at occurrence of overtravel.
Failure to observe this caution may cause workpieces to fall off due to overtravel.
- When not using the normal autotuning, set to the correct moment of inertia ratio.
Setting to an incorrect moment of inertia ratio may cause vibration.
- Do not touch the SERVOPACK heatsinks or servomotor while power is ON or soon after the power is turned OFF.
Failure to observe this caution may result in burns due to high temperatures.
- Do not make any extreme adjustments or setting changes of parameters.
Failure to observe this caution may result in injury due to unstable operation.
- When an alarm occurs, remove the cause, reset the alarm after confirming safety, and then resume operation.
Failure to observe this caution may result in injury.
- Do not use the servo brake of the servomotor for ordinary braking.
Failure to observe this caution may result in malfunction.

■ Maintenance and Inspection

CAUTION

- When replacing the SERVOPACK, transfer the previous SERVOPACK parameters to the new SERVOPACK before resuming operation.
Failure to observe this caution may result in damage to the product.
- Do not attempt to change wiring while the power is ON.
Failure to observe this caution may result in electric shock or injury.
-  • Do not disassemble the servomotor.
Failure to observe this caution may result in electric shock or injury.

■ Disposal

CAUTION

- When disposing of the products, treat them as ordinary industrial waste.

■ General Precautions

Note the following to ensure safe application.

- The drawings presented in this manual are sometimes shown without covers or protective guards. Always replace the cover or protective guard as specified first, and then operate the products in accordance with the manual.
- The drawings presented in this manual are typical examples and may not match the product you received.
- This manual is subject to change due to product improvement, specification modification, and manual improvement. When this manual is revised, the manual code is updated and the new manual is published as a next edition.
- If the manual must be ordered due to loss or damage, inform your nearest Yaskawa representative or one of the offices listed on the back of this manual.
- Yaskawa will not take responsibility for the results of unauthorized modifications of this product. Yaskawa shall not be liable for any damages or troubles resulting from unauthorized modification.

CONTENTS

About this Manual	iii
Related Manuals	v
Safety Information	vi
Notes for Safe Operation	vii

1 Outline

1.1 Checking Products	1-2
1.1.1 Check Items	1-2
1.1.2 Servomotors	1-2
1.1.3 SERVOPACKs	1-3
1.2 Product Part Names	1-4
1.2.1 Servomotors Without Gears and Brakes	1-4
1.2.2 SERVOPACKs	1-5
1.3 Examples of Servo System Configurations	1-6
1.4 Applicable Standards	1-7
1.4.1 North American Safety Standards (UL, CSA)	1-7
1.4.2 CE Marking	1-7

2 Selections

2.1 Servomotor Model Designations	2-2
2.1.1 Model SGMMJ	2-2
2.1.2 Model SGMAJ	2-4
2.2 SERVOPACK Model Designations	2-6
2.3 SGDJ SERVOPACKs and Applicable Servomotors	2-7
2.4 Selecting Cables	2-8
2.5 Selecting Peripheral Devices	2-12
2.5.1 Special Options	2-12
2.5.2 Molded-case Circuit Breaker and Fuse Capacity	2-13
2.5.3 AC/DC Power Supply and Power Supply Input Capacitor	2-14
2.5.4 Noise Filters, Surge Suppressors, Magnetic Conductors, and Brake Power Supply	2-15

3 Specifications and Dimensional Drawings

3.1 Ratings and Specifications of SGMMJ (3000 min ⁻¹)	3-2
3.1.1 SGMMJ Servomotors Without Gears	3-2
3.1.2 SGMMJ Servomotors With Standard Backlash Gears	3-4

3.2	Ratings and Specifications of SGMAJ (3000min ⁻¹)	3-5
3.2.1	SGMAJ Servomotors Without Gears	3-5
3.2.2	SGMAJ Servomotors With Standard Backlash Gears	3-8
3.2.3	SGMAJ Servomotors With Low-backlash Gears	3-10
3.3	Mechanical Specifications of SGMMJ and SGMAJ Servomotors	3-12
3.3.1	Precautions on Servomotor Installation	3-12
3.3.2	Mechanical Characteristics of SGMMJ Servomotors	3-14
3.3.3	Mechanical Characteristics of SGMAJ Servomotors	3-15
3.4	Terms and Data for Servomotors With Gears	3-17
3.5	Dimensional Drawings of SGMMJ Servomotors (3000min ⁻¹)	3-19
3.5.1	SGMMJ Servomotors (3000min ⁻¹) Standard and Without Brakes	3-19
3.5.2	SGMMJ Servomotors (3000min ⁻¹) Standard and With Brakes	3-20
3.5.3	SGMMJ Servomotor (3000min ⁻¹) With Gears and Without Brakes	3-21
3.5.4	SGMMJ Servomotors (3000min ⁻¹) With Gears and Brakes	3-23
3.6	Dimensional Drawings of SGMAJ Servomotors (3000 min ⁻¹)	3-25
3.6.1	SGMAJ Servomotors (3000 min ⁻¹) Without Gears	3-25
3.6.2	SGMAJ Servomotors (3000 min ⁻¹) Without Gears and With Brakes	3-28
3.6.3	SGMAJ Servomotors (3000 min ⁻¹) With Standard Backlash Gears and Without Brakes	3-30
3.6.4	SGMAJ Servomotors (3000 min ⁻¹) With Standard Backlash Gears and Brakes	3-35
3.6.5	SGMAJ Servomotors (3000 min ⁻¹) With Low-backlash Gears and Without Brakes	3-39
3.7	Dimensional Drawing of Output Shafts With Oil Seals	3-43
4	SERVOPACK Specifications and Dimensional Drawings	
4.1	SERVOPACK Ratings and Specifications	4-2
4.1.1	SERVOPACK Ratings and Specifications 1	4-2
4.1.2	SERVOPACK Ratings and Specifications 2	4-3
4.2	SERVOPACK Installation	4-5
4.3	SERVOPACK Internal Block Diagrams	4-7
4.3.1	Speed and Torque Control (SGDJ-□□□S)	4-7
4.3.2	Position Control (SGDJ-□□□P)	4-8
4.4	SERVOPACK's Power Supply Capacities and Power Losses	4-9
4.5	SERVOPACK Overload Characteristics and Allowable Load Moment of Inertia	4-10
4.5.1	Overload Characteristics	4-10
4.5.2	Starting and Stopping Time	4-11
4.5.3	Load Moment of Inertia	4-11
4.5.4	Overhanging Loads	4-12

4.6	Dimensional Drawings	4-13
4.6.1	24 VDC: 10/50 W (A1C□/A5C□)	
	48 VDC: 50 W to 200 W (A5E□ to 02E□)	4-13
4.6.2	24 VDC: 80 W (A8C□)	
	48 VDC: 300 W (03E□)	4-13

5 Specifications and Dimensional Drawings of Cables and Peripheral Devices

5.1	Specifications and Dimensional Drawings of Servomotor Main Circuit Cable	5-2
5.1.1	Cables for SGMMJ and SGMAJ Servomotors Without Brakes	5-2
5.1.2	Cables for SGMMJ and SGMAJ Servomotors With Brakes	5-3
5.2	Servomotor and SERVOPACK Main Circuit Wire Size and Connectors	5-4
5.2.1	Wire Size	5-4
5.2.2	SGMMJ Servomotor Connectors for Standard Environments	5-5
5.2.3	SGMAJ Servomotor Connectors for Standard Environments	5-6
5.3	Encoder Cables for CN4 Connector	5-10
5.3.1	Encoder Cable With Connectors	5-10
5.3.2	Encoder Cable With a SERVOPACK Connector and Encoder Loose Leads	5-10
5.4	Connectors and Cables for Encoder Signals	5-11
5.4.1	Connectors and Cables	5-11
5.5	I/O Signal Cables for CN1 Connector	5-13
5.5.1	Standard Cables	5-13
5.5.2	Connector Type and Cable Size	5-13
5.5.3	Connection Diagram	5-15
5.6	Peripheral Devices	5-16
5.6.1	Cables for Connecting Personal Computers	5-16
5.6.2	Digital Operator	5-17
5.6.3	Cables for Analog Monitor	5-18
5.6.4	Connector Terminal Block Converter Unit	5-19
5.6.5	Noise Filter	5-21
5.6.6	Surge Suppressor	5-21
5.6.7	Variable Resistor for Speed and Torque Setting	5-21
5.6.8	Encoder Signal Converter Unit	5-22

6 Wiring

6.1	Wiring Main Circuit	6-2
6.1.1	Names and Functions of Main Circuit Terminals	6-2
6.1.2	Wiring Main Circuit Power Supply Connector	6-3
6.1.3	Typical Main Circuit Wiring Examples	6-4

6.2	Wiring Encoders-----	6-5
6.2.1	Connecting an Encoder (CN2) and Output Signals from the SERVOPACK (CN1)-----	6-5
6.2.2	Encoder Connector (CN2) Terminal Layout-----	6-6
6.3	Examples of I/O Signal Connections-----	6-7
6.3.1	SGDJ-□□□S for Speed Control Mode-----	6-7
6.3.2	SGDJ-□□□P for Position Control Mode-----	6-8
6.3.3	SGDJ-□□□S for Torque Control Mode-----	6-9
6.3.4	I/O Signal Connector (CN1) Terminal Layout-----	6-10
6.3.5	I/O Signal (CN1) Names and Functions-----	6-12
6.3.6	Interface Circuit-----	6-14
6.4	Others-----	6-17
6.4.1	Wiring Precautions-----	6-17
6.4.2	Wiring for Noise Control-----	6-18
6.4.3	Installation Conditions of EMC Directives-----	6-21
6.4.4	Using More Than One SERVOPACK-----	6-23
6.4.5	Extending Encoder Cables-----	6-24

7 Digital Operator

7.1	Functions on Digital Operator-----	7-2
7.1.1	Connecting the Digital Operator-----	7-2
7.1.2	Key Names and Functions-----	7-3
7.1.3	Basic Mode Selection and Operation-----	7-4
7.1.4	Status Display-----	7-5
7.2	Operation in Utility Function Mode (Fn□□□)-----	7-7
7.2.1	List of Utility Function Modes-----	7-7
7.2.2	Alarm Traceback Data Display (Fn000)-----	7-8
7.2.3	Zero-point Search Mode (Fn003)-----	7-9
7.2.4	Parameter Settings Initialization (Fn005)-----	7-10
7.2.5	Alarm Traceback Data Clear (Fn006)-----	7-11
7.2.6	Automatic Offset-adjustment of Motor Current Detection Signal (Fn00E)-----	7-12
7.2.7	Manual Offset-adjustment of Motor Current Detection Signal (Fn00F)-----	7-13
7.2.8	Password Setting (Protects Parameters from Being Changed) (Fn010)-----	7-14
7.2.9	Motor Models Display (Fn011)-----	7-15
7.2.10	Software Version Display (Fn012)-----	7-16
7.3	Operation in Parameter Setting Mode (Pn□□□)-----	7-17
7.3.1	Setting Parameters-----	7-17
7.3.2	Input Circuit Signal Allocation-----	7-21
7.3.3	Output Circuit Signal Allocation-----	7-24
7.4	Operation in Monitor Mode (Un□□□)-----	7-26
7.4.1	List of Monitor Modes-----	7-26

8 Operation

8.1 Trial Operation - - - - -	8-4
8.1.1 Trial Operation for Servomotor without Load- - - - -	8-6
8.1.2 Trial Operation for Servomotor without Load from Host Reference - - -	8-9
8.1.3 Trial Operation with the Servomotor Connected to the Machine - - - -	8-15
8.1.4 Servomotor with Brakes - - - - -	8-16
8.1.5 Position Control by Host Controller - - - - -	8-16
8.2 Control Mode Selection- - - - -	8-17
8.3 Setting Common Basic Functions - - - - -	8-18
8.3.1 Setting the Servo ON Signal - - - - -	8-18
8.3.2 Switching the Servomotor Rotation Direction - - - - -	8-19
8.3.3 Setting the Overtravel Limit Function - - - - -	8-20
8.3.4 Setting for Holding Brakes - - - - -	8-22
8.3.5 Selecting the Stopping Method After Servo OFF - - - - -	8-25
8.3.6 Instantaneous Power Loss Settings- - - - -	8-26
8.4 Absolute Encoders - - - - -	8-27
8.4.1 Interface Circuits - - - - -	8-28
8.4.2 Selecting an Absolute Encoder - - - - -	8-29
8.4.3 Handling Batteries - - - - -	8-29
8.4.4 Replacing Batteries - - - - -	8-29
8.4.5 Absolute Encoder Setup (Fn008)- - - - -	8-30
8.4.6 Absolute Encoder Reception Sequence - - - - -	8-31
8.4.7 Multiturn Limit Setting - - - - -	8-35
8.4.8 Multiturn Limit Setting When Multiturn Limit Disagreement (A.CC) Occurred- - - - -	8-36
8.5 Operating Using Speed Control with Analog Reference - - -	8-37
8.5.1 Setting Parameters - - - - -	8-37
8.5.2 Setting Input Signals - - - - -	8-38
8.5.3 Adjusting Offset - - - - -	8-39
8.5.4 Soft Start- - - - -	8-42
8.5.5 Speed Reference Filter- - - - -	8-42
8.5.6 Using the Zero Clamp Function- - - - -	8-42
8.5.7 Encoder Signal Output - - - - -	8-44
8.5.8 Speed Coincidence Output - - - - -	8-46
8.6 Operating Using Position Control- - - - -	8-47
8.6.1 Setting Parameters - - - - -	8-47
8.6.2 Setting the Electronic Gear- - - - -	8-49
8.6.3 Position Reference- - - - -	8-52
8.6.4 Smoothing- - - - -	8-56
8.6.5 Positioning Completed Output Signal- - - - -	8-57
8.6.6 Positioning Near Signal - - - - -	8-58
8.6.7 Reference Pulse Inhibit Function (INHIBIT) - - - - -	8-59

8.7	Operating Using Torque Control-----	8-60
8.7.1	Setting Parameters-----	8-60
8.7.2	Torque Reference Input-----	8-60
8.7.3	Adjusting the Reference Offset-----	8-61
8.7.4	Limiting Servomotor Speed during Torque Control-----	8-63
8.8	Operating Using Speed Control with an Internally Set Speed-----	8-65
8.8.1	Setting Parameters-----	8-65
8.8.2	Input Signal Settings-----	8-66
8.8.3	Operating Using an Internally Set Speed-----	8-66
8.9	Limiting Torque-----	8-68
8.9.1	Internal Torque Limit (Limiting Maximum Output Torque)-----	8-68
8.9.2	External Torque Limit (Output Torque Limiting by Input Signals)-----	8-69
8.9.3	Torque Limiting Using an Analog Voltage Reference-----	8-71
8.9.4	Torque Limiting Using an External Torque Limit and Analog Voltage Reference-----	8-72
8.9.5	Checking Output Torque Limiting during Operation-----	8-73
8.10	Control Mode Selection-----	8-74
8.10.1	Setting Parameters-----	8-74
8.10.2	Switching the Control Mode-----	8-74
8.11	Other Output Signals-----	8-76
8.11.1	Servo Alarm Output (ALM) and Alarm Code Output (ALO1, ALO2, ALO3)-----	8-76
8.11.2	Warning Output (/WARN)-----	8-77
8.11.3	Running Output Signal (/TGON)-----	8-77
8.11.4	Servo Ready (/S-RDY) Output-----	8-78

9 Adjustments

9.1	Autotuning-----	9-2
9.1.1	Servo Gain Adjustment Methods-----	9-2
9.1.2	List of Servo Adjustment Functions-----	9-3
9.2	Online Autotuning-----	9-5
9.2.1	Online Autotuning-----	9-5
9.2.2	Online Autotuning Procedure-----	9-6
9.2.3	Selecting the Online Autotuning Execution Method-----	9-7
9.2.4	Machine Rigidity Setting for Online Autotuning-----	9-8
9.2.5	Method for Changing the Machine Rigidity Setting-----	9-9
9.2.6	Saving the Results of Online Autotuning-----	9-10
9.2.7	Procedure for Saving the Results of Online Autotuning-----	9-10
9.3	Manual Tuning-----	9-11
9.3.1	Explanation of Servo Gain-----	9-11
9.3.2	Servo Gain Manual Tuning-----	9-12
9.3.3	Position Loop Gain-----	9-12
9.3.4	Speed Loop Gain-----	9-13
9.3.5	Speed Loop Integral Time Constant-----	9-13

9.4	Servo Gain Adjustment Functions	9-14
9.4.1	Feed-forward Reference	9-14
9.4.2	Torque Feed-forward	9-15
9.4.3	Proportional Control Operation (Proportional Operation Reference)	9-16
9.4.4	Using the Mode Switch (P/PI Switching)	9-17
9.4.5	Setting the Speed Bias	9-20
9.4.6	Speed Feedback Filter	9-20
9.4.7	Speed Feedback Compensation	9-21
9.4.8	Switching Gain Settings	9-23
9.4.9	Torque Reference Filter	9-24
9.5	Analog Monitor	9-26
9.5.1	Related Parameters	9-27
9.5.2	Manual Zero Adjustment and Gain Adjustment of Analog Monitor Output (Fn00C, Fn00D)	9-28
10	Inspection, Maintenance, and Troubleshooting	
10.1	Troubleshooting	10-2
10.1.1	Alarm Display Table	10-2
10.1.2	Warning Display	10-4
10.1.3	Troubleshooting of Alarm and Warning	10-5
10.1.4	Troubleshooting for Malfunction without Alarm Display	10-13
10.2	Inspection and Maintenance	10-18
10.2.1	Servomotor Inspection	10-18
10.2.2	SERVOPACK Inspection	10-18
10.2.3	SERVOPACK's Parts Replacement Schedule	10-19
10.3	Connection to Host Controller	10-20
10.3.1	Example of Connection to MP920 4-axes Analog Module SVA-01	10-20
10.3.2	Example of Connection to CP-9200SH Servo Controller Module SVA (SERVOPACK in Speed Control Mode)	10-21
10.3.3	Example of Connection to MEMOCON GL120/130 Series Motion Module MC20	10-22
10.3.4	Example of Connection to MEMOCON GL60/70 Series Positioning Module B2813 (SERVOPACK in Position Control Mode)	10-23
10.3.5	Example of Connection to OMRON's Motion Control Unit	10-24
10.3.6	Example of Connection to OMRON's Position Control Unit	10-25
10.3.7	Example of Connection to OMRON's Position Control Unit C500-NC221 (SERVOPACK in Speed Control Mode)	10-26
10.3.8	Example of Connection to OMRON's Position Control Unit C500-NC112 (SERVOPACK in Position Control Mode)	10-27
10.3.9	Example of Connection to MITSUBISHI's AD72 Positioning Unit (SERVOPACK in Speed Control Mode)	10-28
10.3.10	Example of Connection to MITSUBISHI's AD75 Positioning Unit (SERVOPACK in Position Control Mode)	10-29
10.4	List of Parameters	10-30
10.4.1	Utility Functions List	10-30
10.4.2	List of Parameters	10-31
10.4.3	Monitor Modes	10-47

INDEX

Revision History

Outline

1.1 Checking Products	1-2
1.1.1 Check Items	1-2
1.1.2 Servomotors	1-2
1.1.3 SERVOPACKs	1-3
1.2 Product Part Names	1-4
1.2.1 Servomotors Without Gears and Brakes	1-4
1.2.2 SERVOPACKs	1-5
1.3 Examples of Servo System Configurations	1-6
1.4 Applicable Standards	1-7
1.4.1 North American Safety Standards (UL, CSA)	1-7
1.4.2 CE Marking	1-7

1.1 Checking Products

The following procedure is used to check the AC servodrives of Σ -II Series products on delivery.

1.1.1 Check Items

Check the following items when Σ -II Series products are delivered.

Check Items	Comments
Are the delivered products the ones that were ordered?	Check the model numbers marked on the nameplates on the servomotor and SERVOPACK. (Refer to the descriptions of model numbers in the following section.)
Does the servomotor shaft rotate smoothly?	The servomotor shaft is normal if it can be turned smoothly by hand. Servomotors with brakes, however, cannot be turned manually.
Is there any damage?	Check the overall appearance, and check for damage or scratches that may have occurred during shipping.

If any of the above items are faulty or incorrect, contact your Yaskawa representative or the dealer from whom you purchased the products.

1.1.2 Servomotors

(1) SGMMJ

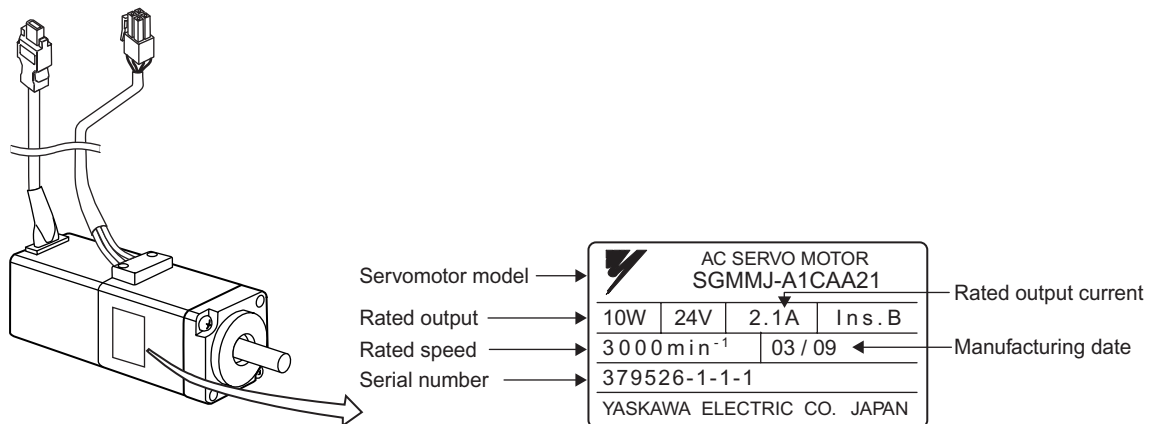

(2) SGMAJ

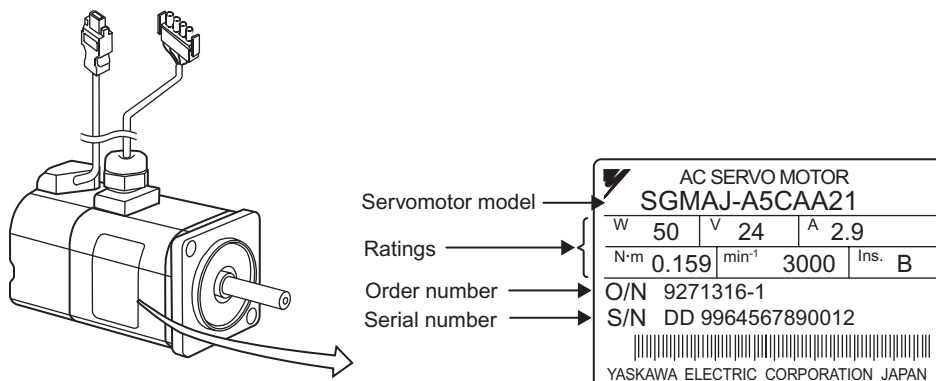

1.1.3 SERVOPACKs

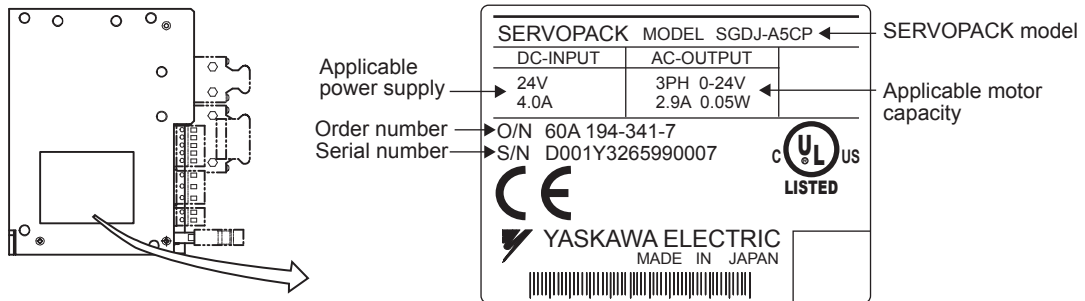

1.2 Product Part Names

1.2.1 Servomotors Without Gears and Brakes

(1) SGMMJ

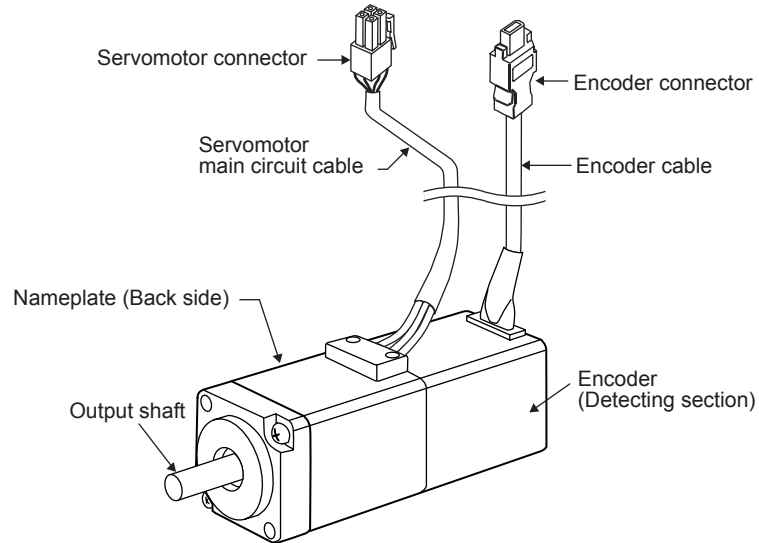

(2) SGMAJ

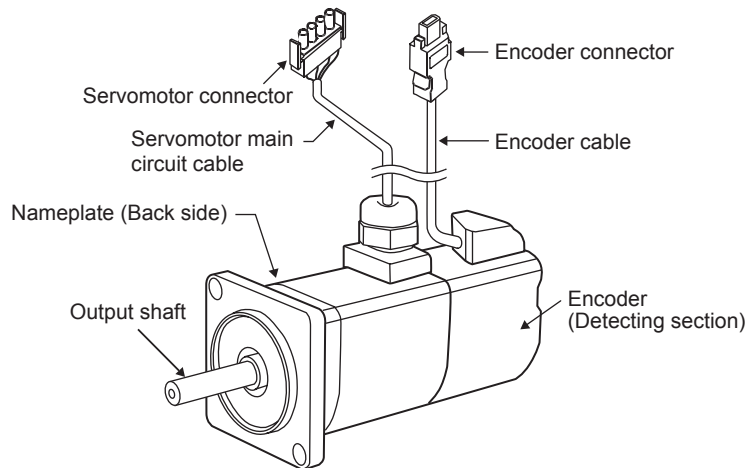

1.2.2 SERVOPACKs

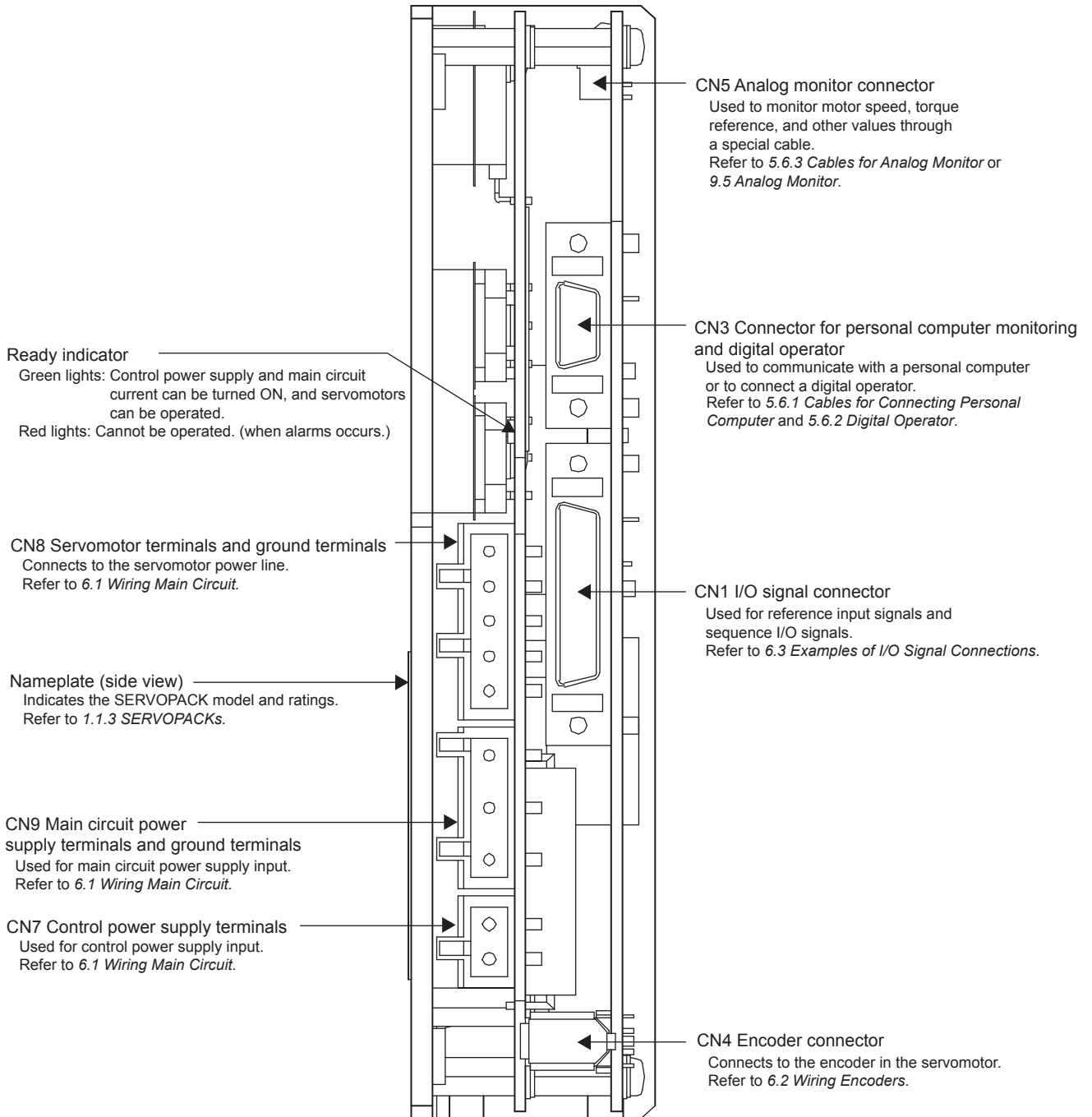

1

1.3 Examples of Servo System Configurations

This section describes examples of basic servo system configuration.

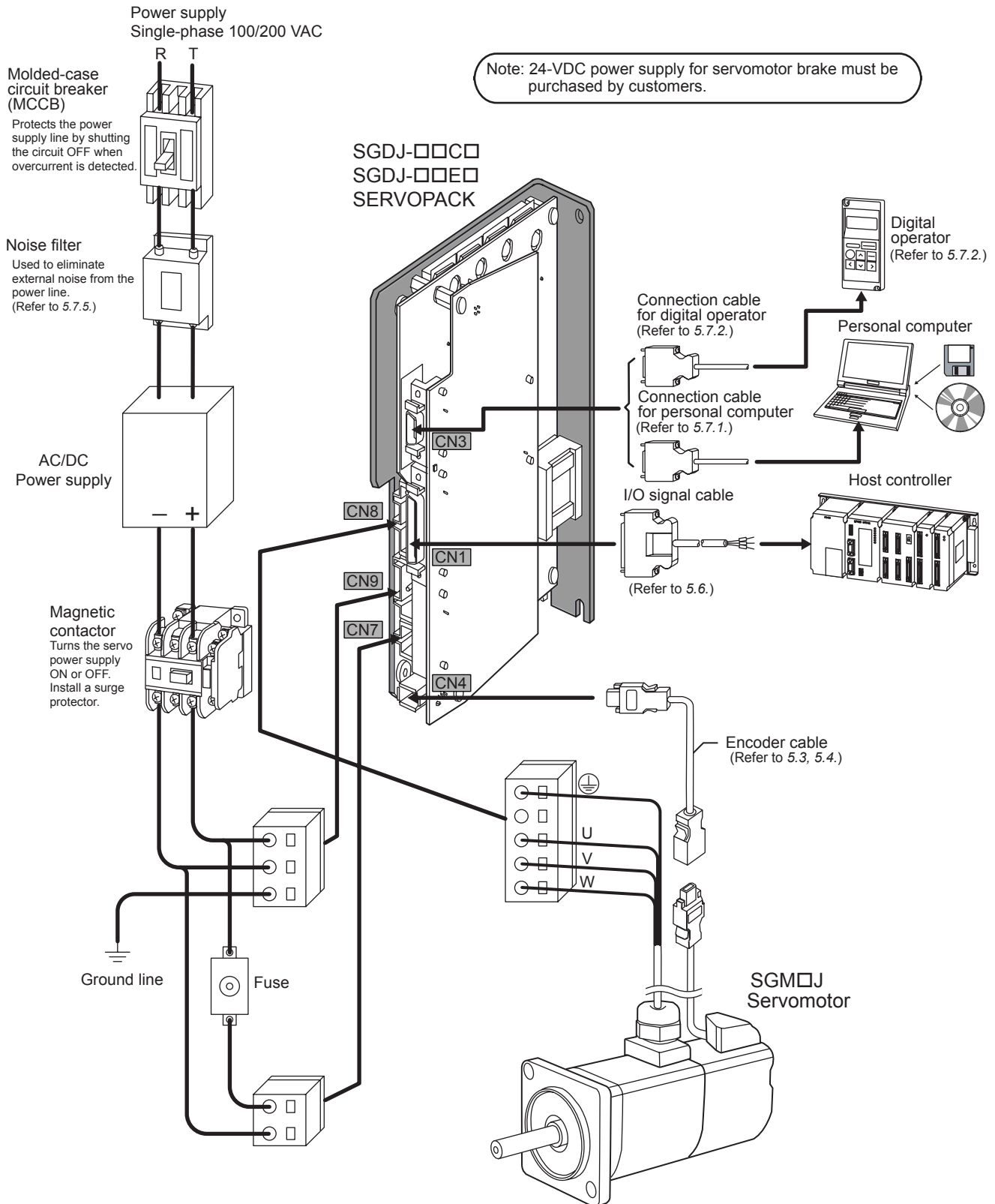

1.4 Applicable Standards

Σ-II Series servodrives conform to the following overseas standards.

1.4.1 North American Safety Standards (UL, CSA)



Model		UL *1 Standards (UL File No.)	CSA *2 Standards	Certifications
SERVOPACK	• SGDJ	UL508C(E147823)	CSA C22.2 No.14	UL
Servomotor	• SGMMJ • SGMAJ	UL1004(E165827)	CSA C22.2 No.100	

* 1. Underwriters Laboratories Inc.

* 2. Canadian Standards Association.

1.4.2 CE Marking



Model		Low Voltage Directive	EMC Directive		Certifications
			EMI	EMS	
SERVOPACK	• SGDJ	EN50178	EN55011 group 1 class A	EN50082-2 or EN61000-6-2	TÜV PS*
Servomotor	• SGMMJ • SGMAJ	IEC60034-1 IEC60034-5 IEC60034-8 IEC60034-9			

* TÜV Product Services GmbH

Note: For installation conditions, refer to 6.4.2 *Wiring for Noise Control*.

Because SERVOPACKs and servomotors are built-in type, reconfirmation is required after being installed in the final product.

2.1 Servomotor Model Designations	2-2
2.1.1 Model SGMMJ	2-2
2.1.2 Model SGMAJ	2-4
2.2 SERVOPACK Model Designations	2-6
2.3 SGDJ SERVOPACKs and Applicable Servomotors	2-7
2.4 Selecting Cables	2-8
2.5 Selecting Peripheral Devices	2-12
2.5.1 Special Options	2-12
2.5.2 Molded-case Circuit Breaker and Fuse Capacity	2-13
2.5.3 AC/DC Power Supply and Power Supply Input Capacitor	2-14
2.5.4 Noise Filters, Surge Suppressors, Magnetic Conductors, and Brake Power Supply	2-15

2.1 Servomotor Model Designations

This section explains how to check the servomotor model and ratings. The alphanumeric codes after SGM□H indicate the specifications.

2.1.1 Model SGMMJ

(1) Standard Type

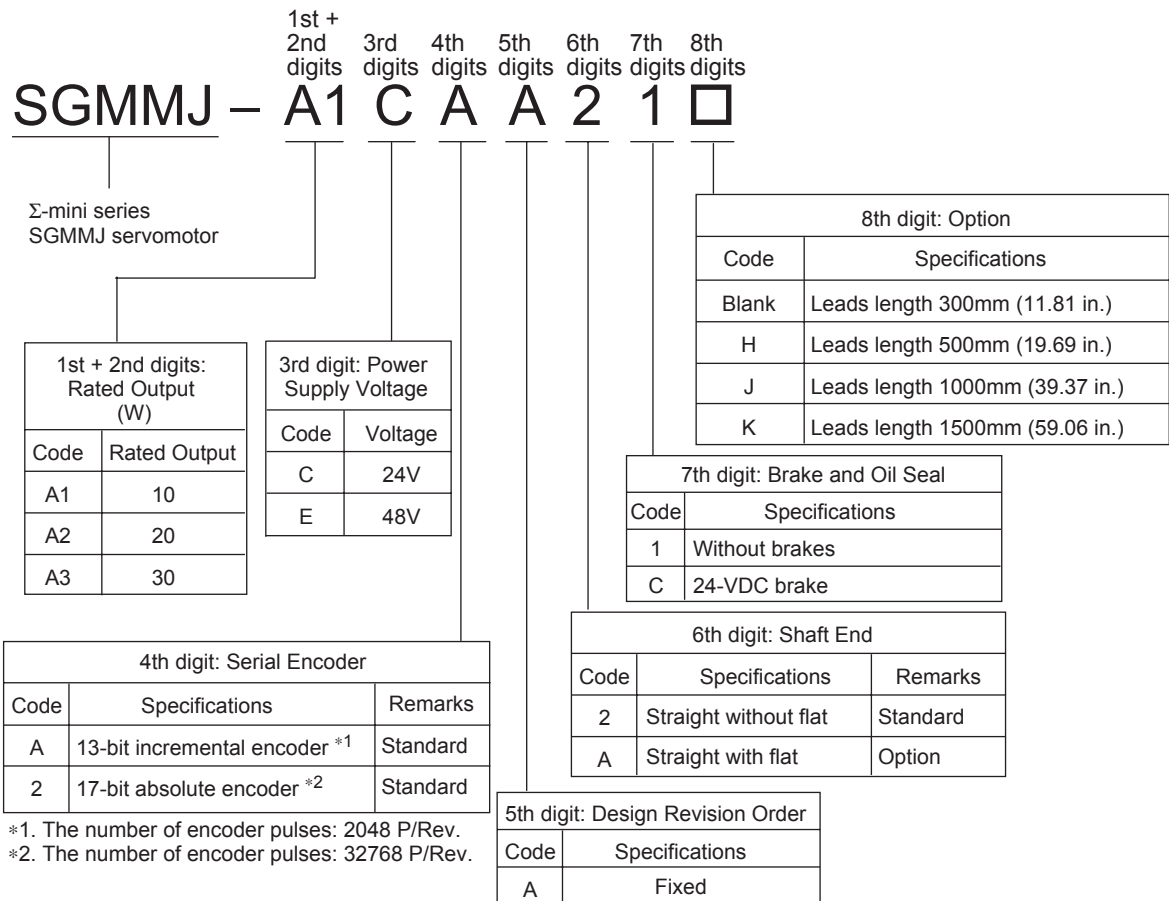

(2) With Gears

1st + 2nd digits: Rated Output (W)
 3rd digit: Power Supply Voltage
 4th digit: Serial Encoder
 5th digit: Design Revision Order
 6th digit: Gears
 7th digit: Gear Ratio
 8th digit: Shaft End
 9th digit: Brake and Oil Seal
 10th digit: Option

SGMMJ – A1 C A A J 1 2 1 □

Σ-mini series
SGMMJ servomotor

1st + 2nd digits: Rated Output (W)	
Code	Rated Output
A1	10
A2	20
A3	30

3rd digit: Power Supply Voltage	
Code	Voltage
C	24V
E	48V

4th digit: Serial Encoder		
Code	Specifications	Remarks
A	13-bit incremental encoder *1	Standard
2	17-bit absolute encoder *2	Standard

*1. The number of encoder pulses: 2048 P/Rev.
 *2. The number of encoder pulses: 32768 P/Rev.

5th digit: Design Revision Order	
Code	Specifications
A	Fixed

6th digit: Gears	
Code	Specifications
J	With gears

10th digit: Option	
Code	Specifications
Blank	Leads length 300mm (11.81 in.)
H	Leads length 500mm (19.69 in.)
J	Leads length 1000mm (39.37 in.)
K	Leads length 1500mm (59.06 in.)

9th digit: Brake and Oil Seal	
Code	Specifications
1	Without brakes
C	24-VDC brake

8th digit: Shaft End		
Code	Specifications	Remarks
2	Straight without flat	Standard
6	Straight with key and tap	Option

7th digit: Gear Ratio		
Code	Specifications	Remarks
1	1/5	For SGMMJ-A3 (Gear ratio flange: □40)
2	1/16	
3	1/25	
A	1/5	For SGMMJ-A1 and A2 (Gear ratio flange: □25)
B	1/16	
C	1/25	

2

2.1.2 Model SGMAJ

(1) Standard Type

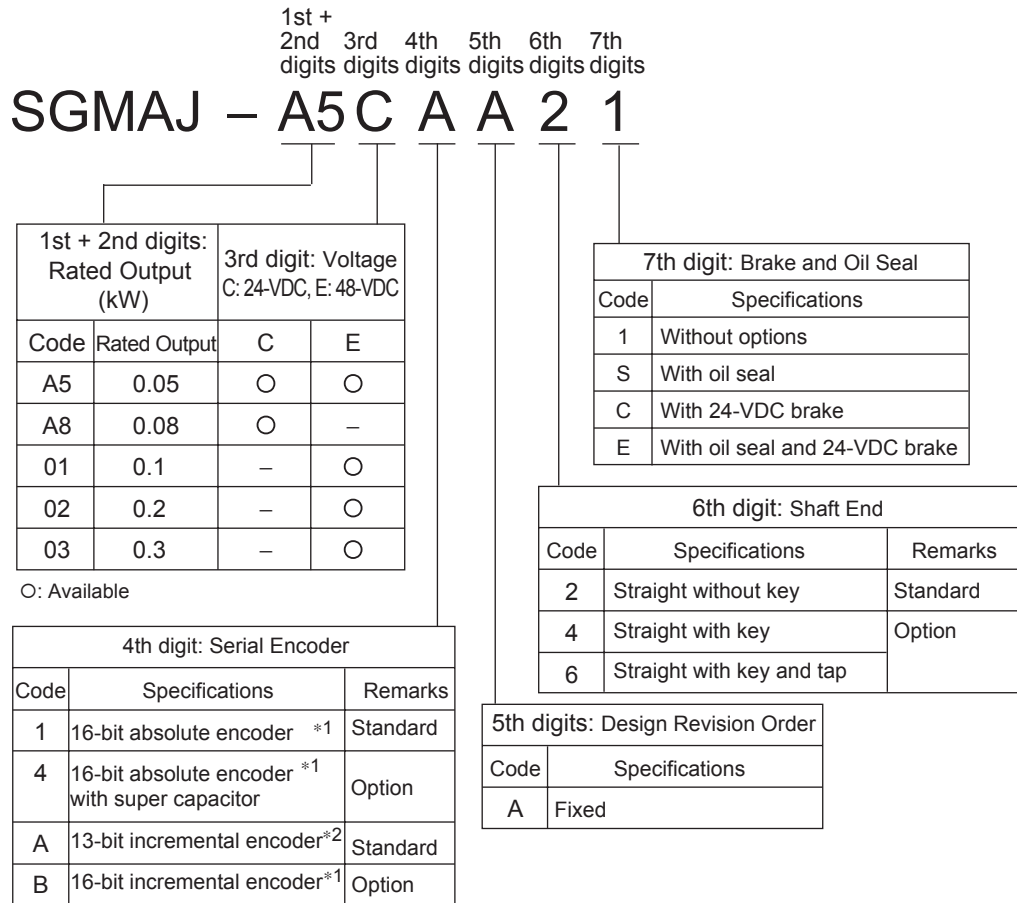

*1 The number of encoder pulses: 16384 P/Rev.

*2 The number of encoder pulses: 2048 P/Rev.

(2) With Gears

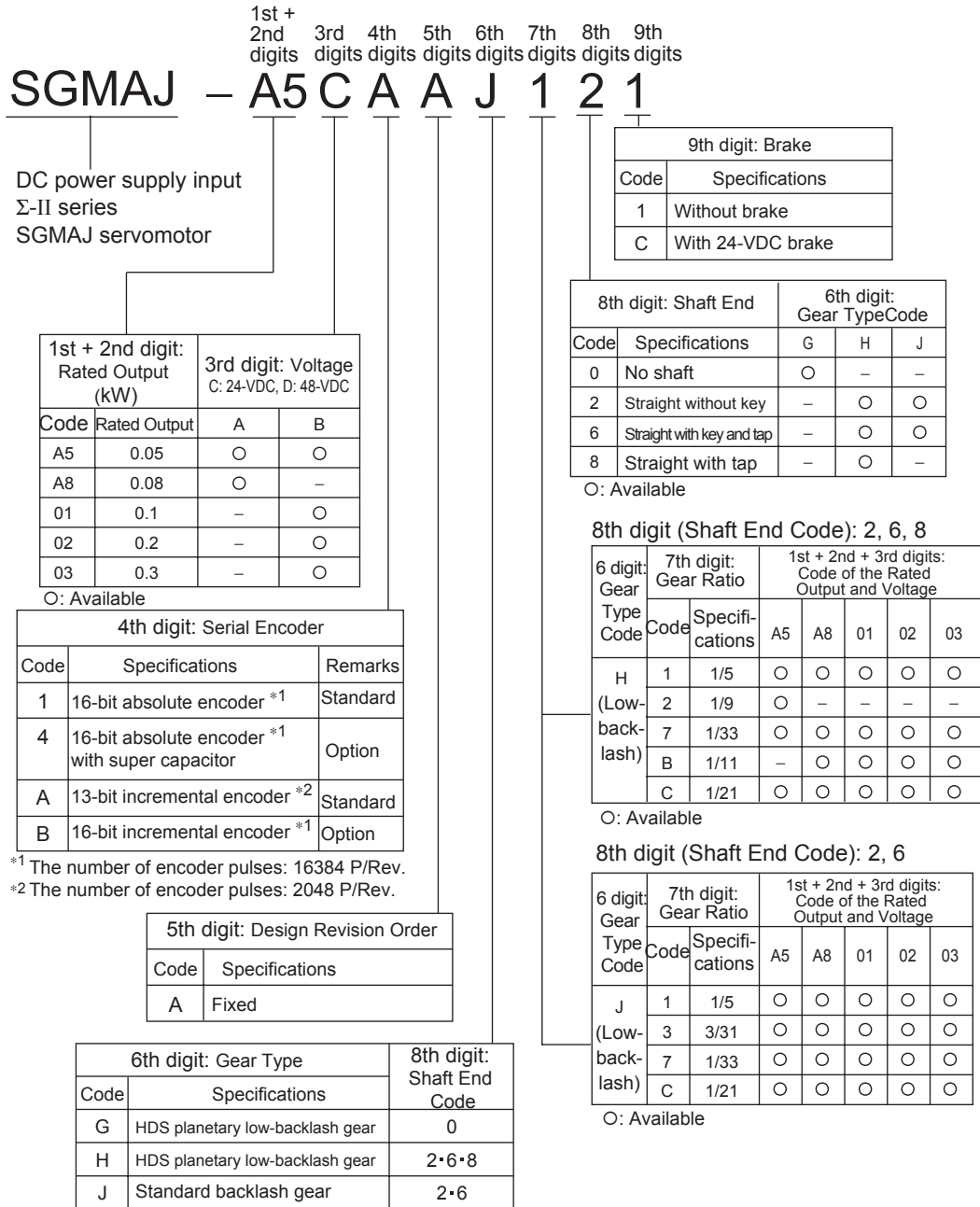

2

2.2 SERVOPACK Model Designations

Select the SERVOPACK according to the applied servomotor.

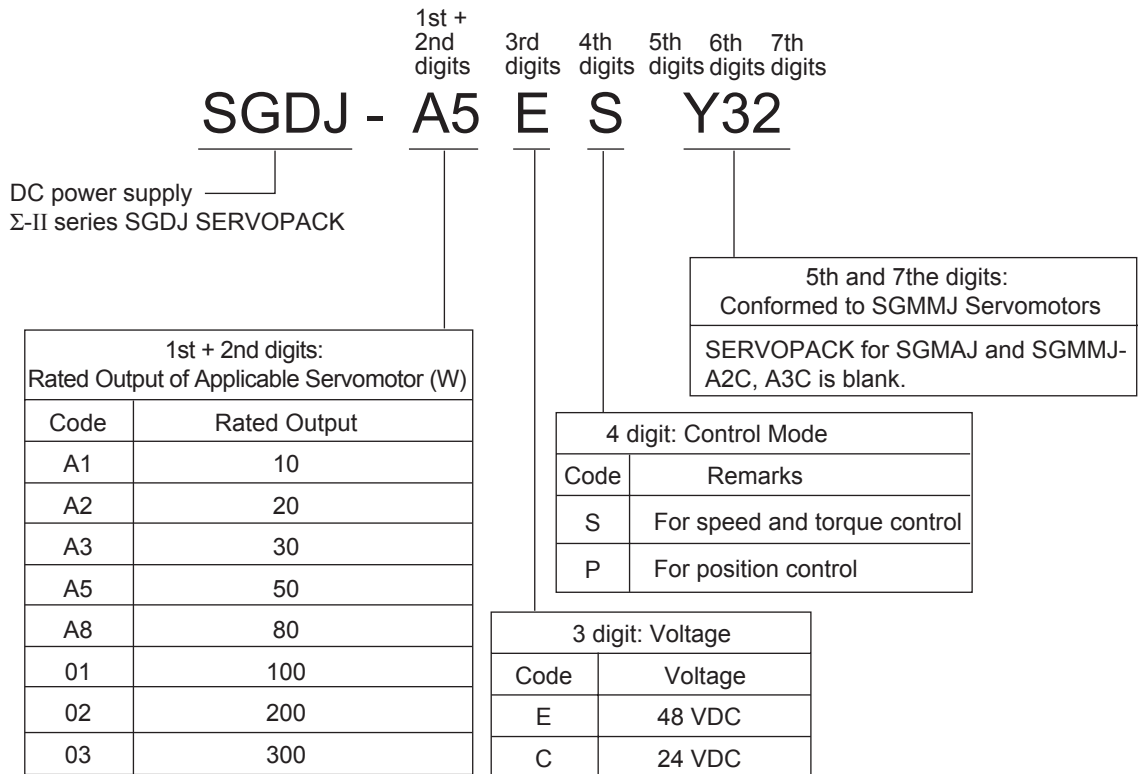





2.3 SGDJ SERVOPACKs and Applicable Servomotors

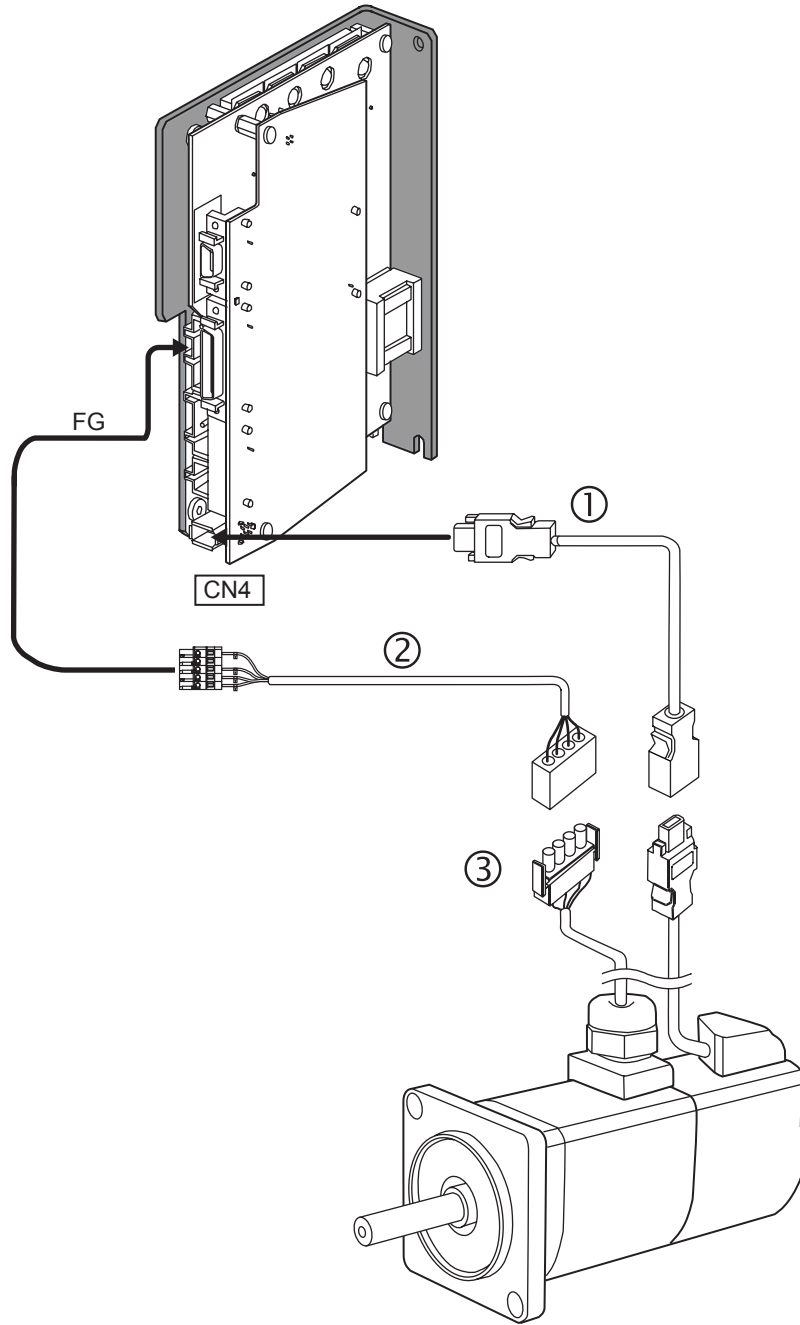

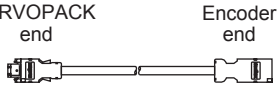
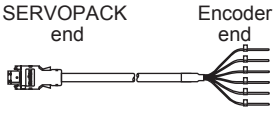
Servomotor			SGDJ SERVOPACK	
			24 VDC	48 VDC
24 VDC	SGMMJ	A1C	A1C□Y32	–
		A2C	A5C□	–
		A3C	A8C□	–
	SGMAJ	A5C	A5C□	–
		A8C	A8C□	–
48 VDC	SGMMJ	A1E	–	A1E□Y32
		A2E	–	A2E□Y32
		A3E	–	A3E□Y32
	SGMAJ	A5E	–	A5E□
		01E	–	01E□
		02E	–	02E□
		03E	–	03E□

2.4 Selecting Cables

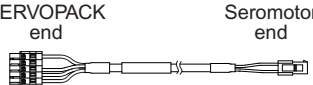
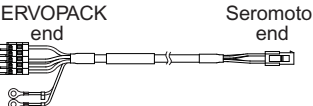
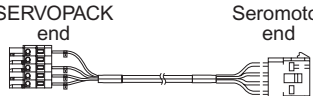
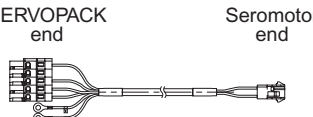

Name		Length	Type	Specifications	Reference	
① CN4 Encoder Cable	Cable with connectors at both ends	3 m (9.84 ft)	JZSP-CMP00-03		5.3.1	
		5 m (16.4 ft)	JZSP-CMP00-05			
		10 m (32.8 ft)	JZSP-CMP00-10			
		15 m (49.2 ft)	JZSP-CMP00-15			
		20 m (65.6 ft)	JZSP-CMP00-20			
	Cable with loose wire at encoder end	3 m (9.84 ft)	JZSP-CMP03-03		5.3.2	
		5 m (16.4 ft)	JZSP-CMP03-05			
		10 m (32.8 ft)	JZSP-CMP03-10			
		15 m (49.2 ft)	JZSP-CMP03-15			
		20 m (65.6 ft)	JZSP-CMP03-20			
	SERVOPACK end connector kit			JZSP-CMP9-1	Soldered 	5.4.1
	Encoder end connector kit			JZSP-CMP9-2	Soldered 	
	Cables	5 m (16.4 ft)	JZSP-CMP09-05	20 m (65.6 ft) max. 		
		10 m (32.8 ft)	JZSP-CMP09-10			
		15 m (49.2 ft)	JZSP-CMP09-15			
		20 m (65.6 ft)	JZSP-CMP09-20	50 m (164.0 ft) max. 		
		30 m (98.4 ft)	JZSP-CMP19-30			
		40 m (131.2 ft)	JZSP-CMP19-40			
		50 m (164.0 ft)	JZSP-CMP19-50			

(cont'd)

Name		Length	Type	Specifications	Reference
② Servomotor Main Circuit Cables and Con- nectors	SGMMJ Without brakes	3 m (9.84 ft)	JZSP-CDM00-03		5.2.2
		5 m (16.4 ft)	JZSP-CDM00-05		
		10 m (32.8 ft)	JZSP-CDM00-10		
		15 m (49.2 ft)	JZSP-CDM00-15		
		20 m (65.6 ft)	JZSP-CDM00-20		
	SGMMJ With brakes	3 m (9.84 ft)	JZSP-CDM10-03		
		5 m (16.4 ft)	JZSP-CDM10-05		
		10 m (32.8 ft)	JZSP-CDM10-10		
		15 m (49.2 ft)	JZSP-CDM10-15		
		20 m (65.6 ft)	JZSP-CDM10-20		
	SGMAJ Without brakes	3 m (9.84 ft)	JZSP-CJM00-03		5.1.1
		5 m (16.4 ft)	JZSP-CJM00-05		
		10 m (32.8 ft)	JZSP-CJM00-10		
		15 m (49.2 ft)	JZSP-CJM00-15		
		20 m (65.6 ft)	JZSP-CJM00-20		
	SGMAJ With brakes	3 m (9.84 ft)	JZSP-CJM10-03		5.1.2
		5 m (16.4 ft)	JZSP-CJM10-05		
		10 m (32.8 ft)	JZSP-CJM10-10		
		15 m (49.2 ft)	JZSP-CJM10-15		
		20 m (65.6 ft)	JZSP-CJM10-20		
SGMMJ connector kit without brakes			JZSP-CFM9-2		5.2.2
SGMMJ connector kit with brakes			JZSP-CFM9-3		

(cont'd)

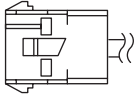
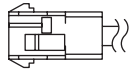
Name		Length	Type	Specifications	Reference
② Servomotor Main Circuit Cables and Connectors (Cont'd)	SGMAJ connector kit with brakes		JZSP-CMM9-1		5.2.2
	SGMAJ connector kit with brakes		JZSP-CMM9-2		
③ Servomotor Connection Connector Kit	For SERVOPACK power supply input connector kit		JZSP-CJG9-2	The following connectors sets are available for purchase. <ul style="list-style-type: none"> • For the control power supply (CN7) • For the main circuit power supply (CN9) 	5.2.2
	SERVOPACK power supply input + servomotor cables connection connector kit		JZSP-CJG9-3	The following connectors sets are available for purchase. <ul style="list-style-type: none"> • For the control power supply (CN7) • For the servomotor main circuit (CN8) • For the main circuit power supply (CN9) 	



For a flexible cable, contact your Yaskawa representative.

2.5 Selecting Peripheral Devices

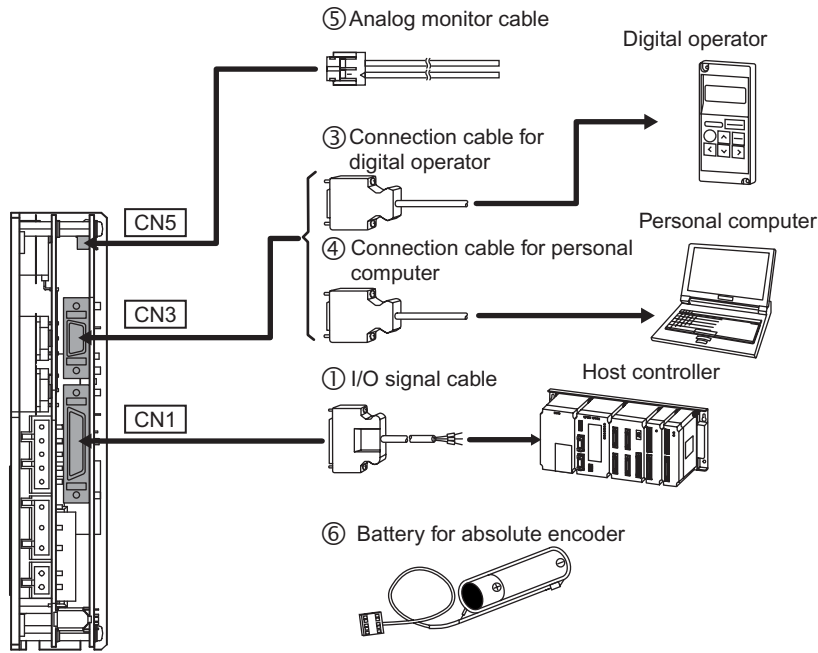





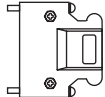

2.5.1 Special Options

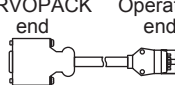

* Install the battery for the absolute encoder on the side of the host controller.

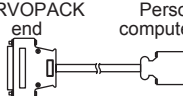
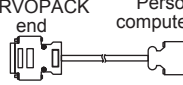
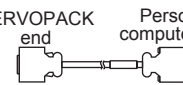
Name	Length	Type	Specifications	Reference	
① CN1 I/O Signal Cables	Connector terminal block converter unit		Terminal block and 0.5 m (1.64 ft) connection cable 	5.6.4	
	Cable with loose wires at one end	1 m (3.28 ft)	JZSP-VAI01-1	Loose wires at host controller end 	5.5.1
		2 m (6.56 ft)	JZSP-VAI01-2		
		3 m (9.84 ft)	JZSP-VAI01-3		
Connector kit		JZSP-VAI09		5.5.2	

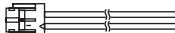
(cont'd)

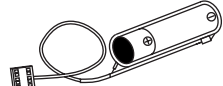
Name	Length	Type	Specifications	Reference
② Digital Operator		JUSP-OP02A-2	With connection cable (1 m (3.28 ft)) 	5.6.2
③  Connection Cable for Digital Operator	1 m (3.28 ft)	JZSP-CMS00-1	Only required when using Σ series Digital Operator JUSP-OP02A-1. 	
	1.5 m (4.92 ft)	JZSP-CMS00-2		
	2 m (6.56 ft)	JZSP-CMS00-3		
④  Connection Cable for Personal Computer	2 m (6.56 ft)	JZSP-CMS01	D-Sub 25-pin (For PC98) 	5.6.1
	2 m (6.56 ft)	JZSP-CMS02	D-Sub 9-pin (For DOS/V) 	
	2 m (6.56 ft)	JZSP-CMS03	Half-pitch 14-pin (For PC 98) 	
⑤  Analog Monitor Cable	1 m (3.28 ft)	JZSP-CA01 or DE9404559	SERVOPACK end Monitor end 	5.6.3
⑥  Battery for Absolute Encoder		ER6VC3	To connect to a host controller (provided by a customer) 3.6 V 2000 mAh, manufactured by Toshiba Battery Co., Ltd. 	5.6.8

2.5.2 Molded-case Circuit Breaker and Fuse Capacity

SERVOPACK model	Voltage	Capacity (W)	Power Supply Capacity per SERVOPACK (kVA)		Current Capacity of the Fuse and the Molded-case Circuit Breaker	
			Continuous Rating (W)	Momentary Rating (W)	Power Supply 100 VAC (Arms)	Power Supply 200 VAC (Arms)
SGDJ-A5C	24 VDC	50	96.6	220	15	7.5
SGDJ-A8C		80	144	320	20	10
SGDJ-A5E	48 VDC	50	92.1	210	15	7.5
SGDJ-01E		100	170	380	22	11
SGDJ-02E		200	322	700	40	20
SGDJ-03E		300	467	1000	60	30

Note: 1. Connect the fuse or the molded-case circuit breaker to the DC side on the control power supply.

2. Select a fuse and a molded-case circuit breaker that are certified by the UL and the CSA and have CE Marking.

The following table shows the fuse or the molded-case circuit breaker specifications.

Control Power Supply Voltage	Applicable SERVOPACK	Fuse or Molded-case Circuit Breaker Specifications	
		Rating Voltage (V)	Rating Current (Arms)
24 VDC	□□C□	30	2.0
48 VDC	□□E□	60	1.0

IMPORTANT

The SGDJ SERVOPACK does not include a protective grounding circuit. Install a ground-fault protector to protect the system against overload and short-circuit or protective grounding combined with the molded-case circuit breaker.

2.5.3 AC/DC Power Supply and Power Supply Input Capacitor

The SGDJ SERVOPACK requires DC power supply. Select an AC/DC power supply that corresponds with the voltage of the SERVOPACK. The following table shows the recommended power supply and the power supply input capacitor.

SERVOPACK Model	Applicable SERVOPACK	Recommended AC/DC Power Supply	
	Voltage	Model	Manufacturer
SGDJ-□□C□	24 VDC	JWS240P-24	Densei-Lambda K.K.
SGDJ-□□E□	48 VDC	JWS480P-48	

* Use a power supply with double insulation that is certified and meets safety standards (UL1950 or EN 60950).

SERVOPACK Model	Voltage	Power Supply Input	Recommended Power Supply Input Capacitor Specification per SERVOPACK					Manufacturer	
			Voltage [V]	Capacity [μ F]	Ripple Current [Arms]	Recommended Model	Number		
SGDJ-□□C□	24 VDC	Control Power Supply Input	50	180	0.64	UPJ1H181MPH	1	NICHICON CORPORATION	
		Main Circuit Power Supply		A5C□	1200	2.2	UPJ1H122MHH		1
				A8C□	2400	4.4	UPJ1H122MHH		2
SGDJ-□□E□	48 VDC	Control Power Supply Input	100	39	0.32	UPJ2A390MPH	1		
		Main Circuit Power Supply		A5E□	330	1.5	UPJ2A331MPH		1
				01E□	1000	4.1	UPJ2A561MHH		2
				02E□	1500	5.7	LGQ2A152MHSA	1	
				03E□	2000	7.5	LGQ2A102MHSA	2	

Note: To limit the voltage variation of the power supply that results from changes in the load of the servomotor, insert the power supply input capacitor as close as possible to the SERVOPACK so that it is parallel to the output side of the AC/DC power supply.

2.5.4 Noise Filters, Surge Suppressors, Magnetic Conductors, and Brake Power Supply

SERVOPACK Model			Noise Filter* ¹		Surge Suppressor* ²	
SGDJ-	Voltage (V)	Capacity (W)	Model	Manufacturer	Model	Manufacturer
A5C□	24 VDC	50	SUP-P8HEPR-4	Okaya Electric Industries Co., Ltd.	CR50500BA	Okaya Electric Industries Co., Ltd.
A8C□		80				
A5E□	48 VDC	50				
01E□		100				
02E□		200				
03E□		300				

Note: 1. Connect a noise filter on the AC side of an AC/DC power supply.

2. Mount the surge suppressor on the magnetic conductors to prevent noise from the power supply and to protect the contacts.

(1) Magnetic Conductors

Connect the magnetic conductors on the DC side of an AC/DC power supply. Select the magnetic conductors according to the capacity of the power supply. If several servo system are being used at the same time, select the magnetic conductors according to the total capacity.

(2) Brake Power Supply

The brakes of the SGMMJ and SGMAJ servomotors are 24 VDC. The 24-VDC brake power supply must be provided by the customer. Be careful when connecting the power supply for 24 VDC brake to the local power supply. The local power supply cannot apply the overvoltage such as surge to the output side, and the output side may be damaged even if the voltage is applied. Never fail to use the surge suppressor.

Specifications and Dimensional Drawings

3.1 Ratings and Specifications of SGMMJ (3000 min ⁻¹)	3-2
3.1.1 SGMMJ Servomotors Without Gears	3-2
3.1.2 SGMMJ Servomotors With Standard Backlash Gears	3-4
3.2 Ratings and Specifications of SGMAJ (3000min ⁻¹)	3-5
3.2.1 SGMAJ Servomotors Without Gears	3-5
3.2.2 SGMAJ Servomotors With Standard Backlash Gears	3-8
3.2.3 SGMAJ Servomotors With Low-backlash Gears	3-10
3.3 Mechanical Specifications of SGMMJ and SGMAJ Servomotors	3-12
3.3.1 Precautions on Servomotor Installation	3-12
3.3.2 Mechanical Characteristics of SGMMJ Servomotors	3-14
3.3.3 Mechanical Characteristics of SGMAJ Servomotors	3-15
3.4 Terms and Data for Servomotors With Gears	3-17
3.5 Dimensional Drawings of SGMMJ Servomotors (3000min ⁻¹)	3-19
3.5.1 SGMMJ Servomotors (3000min ⁻¹) Standard and Without Brakes	3-19
3.5.2 SGMMJ Servomotors (3000min ⁻¹) Standard and With Brakes	3-20
3.5.3 SGMMJ Servomotor (3000min ⁻¹) With Gears and Without Brakes	3-21
3.5.4 SGMMJ Servomotors (3000min ⁻¹) With Gears and Brakes	3-23
3.6 Dimensional Drawings of SGMAJ Servomotors (3000 min ⁻¹)	3-25
3.6.1 SGMAJ Servomotors (3000 min ⁻¹) Without Gears	3-25
3.6.2 SGMAJ Servomotors (3000 min ⁻¹) Without Gears and With Brakes	3-28
3.6.3 SGMAJ Servomotors (3000 min ⁻¹) With Standard Backlash Gears and Without Brakes	3-30
3.6.4 SGMAJ Servomotors (3000 min ⁻¹) With Standard Backlash Gears and Brakes	3-35
3.6.5 SGMAJ Servomotors (3000 min ⁻¹) With Low-backlash Gears and Without Brakes	3-39
3.7 Dimensional Drawing of Output Shafts With Oil Seals	3-43

3.1 Ratings and Specifications of SGMMJ (3000 min⁻¹)

3.1.1 SGMMJ Servomotors Without Gears

(1) Ratings and Specifications

- Time Rating: Continuous
- Vibration Class: 15 μm or below
- Insulation Resistance: 500 VDC, 10 M Ω min.
- Ambient Temperature: 0 to 40°C (32 to 104°F)
- Excitation: Permanent magnet
- Mounting: Flange method
- Thermal Class: B
- Withstand Voltage: 1000 VAC for one minute
400 V Servomotors: 1800 VAC for one minute
- Ambient Humidity: 20% to 80% (no condensation)
- Drive Method: Direct drive

Voltage		For 24 VDC			For 48 VDC			
Servomotor Model SGMMJ-		A1C	A2C	A3C	A1E	A2E	A3E	
Rated Output *1	W	10	20	30	10	20	30	
Rated Torque *1,*2	N·m	0.0318	0.0638	0.0955	0.0318	0.0638	0.0955	
	oz·in *3	4.50	9.03	13.5	4.50	9.03	13.5	
Instantaneous Peak Torque *1	N·m	0.0955	0.191	0.287	0.0955	0.191	0.287	
	oz·in *3	13.5	27.0	40.6	13.5	27.0	40.6	
Rated Current *1	A _{rms}	2.1	2.0	2.9	2.1	2.0	2.9	
Instantaneous Max. Current *1	A _{rms}	6.0	5.7	8.6	6.0	5.7	8.6	
Rated Speed *1	min ⁻¹	3000						
Max. Speed *1	min ⁻¹	5000						
Torque Constant	N·m/A _{rms}	0.0172	0.0358	0.0358	0.0172	0.0358	0.0358	
	oz·in/A _{rms} *3	2.44	5.07	5.07	2.44	5.07	5.07	
Rotor Moment of Inertia J	Incremental	x10 ⁻⁴ kg·m ²	0.00354	0.00548	0.00750	0.00354	0.00548	0.00750
		x10 ⁻³ oz·in·s ² *3	0.0501	0.00776	0.106	0.0501	0.00776	0.106
	Absolute	x10 ⁻⁴ kg·m ²	(0.00272)	(0.00466)	(0.00668)	(0.00272)	(0.00466)	(0.00668)
		x10 ⁻³ oz·in·s ² *3	(0.0385)	(0.0660)	(0.0946)	(0.0385)	(0.0660)	(0.0946)
Rated Power Rate *1	kW/s	2.87	7.41	12.2	2.87	7.41	12.2	
Rated Angular Acceleration *1	rad/s ²	90000	116000	127000	90000	116000	127000	

* 1. These items and torque-motor speed characteristics quoted in combination with an SGDJ SERVOPACK are at an armature winding temperature of 100°C (212°F). Other values quoted at 20°C (68°F). All values are typical.

* 2. Rated torques are continuous allowable torque values at 40°C (104°F) with an aluminum plate (heat sink) attached.

A1 and A2: 150 × 150 × 3 (mm), [5.9 × 5.9 × 0.12 (in.)]

A3: 250 × 250 × 6 (mm), [10 × 10 × 0.24 (in.)]

* 3. These values are reference values.

(2) Holding Brake Moment of Inertia

The moment of inertia of the servomotor with holding brake is expressed using the following equation.

$$(\text{The moment of inertia of the servomotor with holding brake}) = (\text{rotor moment of inertia}) + (\text{brake moment of inertia})$$

Servomotor Model SGMMJ-		A1□	A2□	A3□
Holding Brake Moment of Inertia J	$\times 10^{-4} \text{ kg}\cdot\text{m}^2$	0.00125		
	$\times 10^{-3} \text{ oz}\cdot\text{in}\cdot\text{s}^2$	0.0177		

* These values are reference values.

(3) Holding Brake Electrical Specifications

Holding Brake Rated Voltage	Servomotor Model	Servomotor Capacity W	Holding Brake Specifications			
			Capacity W	Holding Torque N·m (oz·in)	Coil Resistance Ω(at 20°C (68 °F))	Rated Current A (at 20°C (68 °F))
24 VDC	SGMMJ-A1□	10	2.0	0.0318 (4.50)	320	0.08
	SGMMJ-A2□	20	2.6	0.0638 (9.03)	222	0.11
	SGMMJ-A3□	30	2.6	0.0955 (13.5)	220	0.11

Note: The holding brake is only used to hold the load and cannot be used to stop the servomotor.

(4) Torque-motor Speed Characteristics

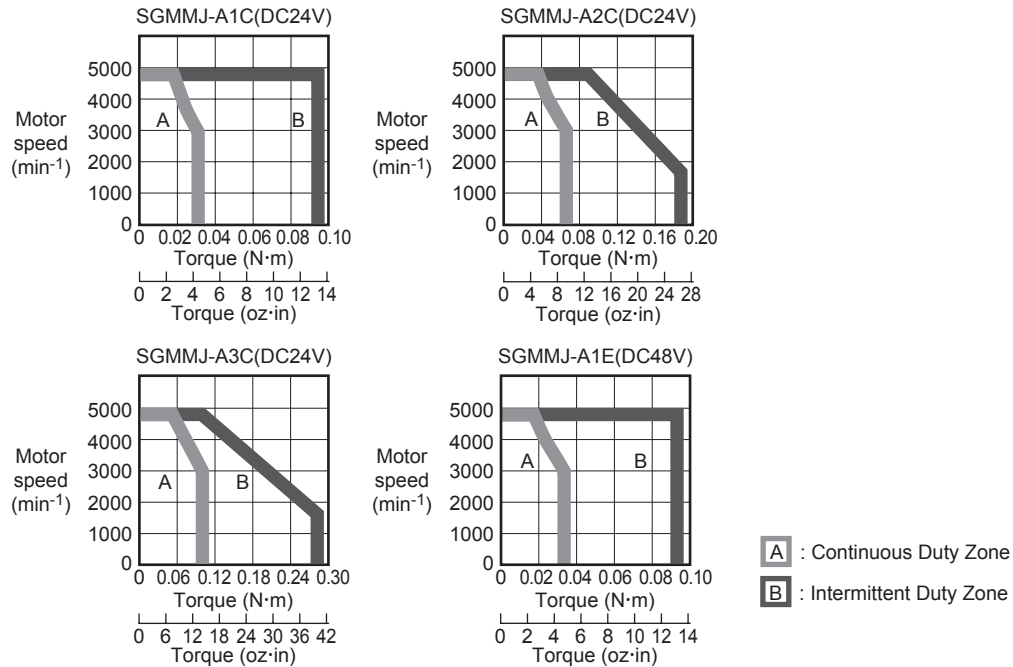

3.1.2 SGMMJ Servomotors With Standard Backlash Gears

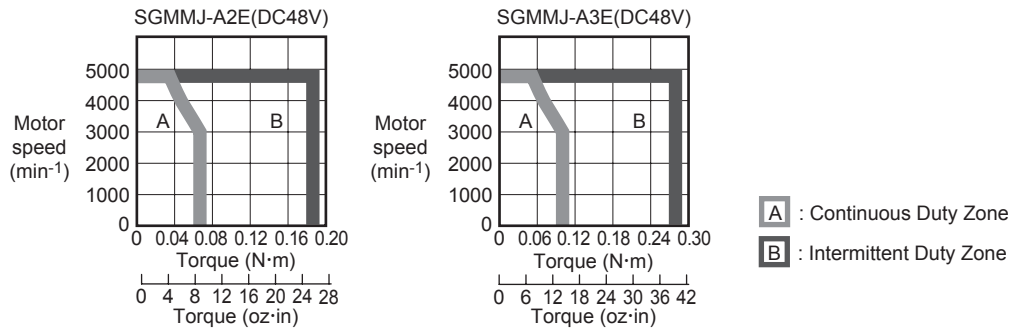

3.1.2 SGMMJ Servomotors With Standard Backlash Gears

- Time Rating: Continuous
- Insulation Resistance: 500 VDC, 10 MΩ min.
- Ambient Temperature: 0 to 40°C (32 to 104°F)
- Excitation: Permanent magnet
- Mounting: Flange method
- Gear Mechanism: Planetary gear mechanism
- Thermal Class: B
- Withstand Voltage: 1000 VAC for one minute
- Enclosure: Totally enclosed, self-cooled, IP55 (except for shaft opening)
- Ambient Humidity: 20% to 80% (no condensation)
- Drive Method: Direct drive
- Backlash: 15 to 20 min max.
- Gear Rotation Direction: Same direction as servomotor

Servomotor Model SGMMJ-	Servomotor			Gear Output					Moment of Inertia J ×10 ⁻⁴ kg·m ² (× 10 ⁻³ oz·in·s ²)	
	Out-put W	Rated Speed min ⁻¹	Rated Torque N·m (oz·in)	Gear Ratio	Rated Torque/ Efficiency*2 N·m/% (oz·in/%)	Instantaneous Peak Torque N·m (oz·in)	Rated Speed min ⁻¹	Max. Speed *1 min ⁻¹	Motor + Gears	Gears
A1□□AJA□□□	10	3000	0.0318 (4.50)	1/5	0.127/80 (18.0/80)	0.43 (60.9)	600	1000	0.00529 (0.0749)	0.00175 (0.0248)
A1□□AJB□□□				1/16	0.407/80 (57.6/80)	1.38 (195)	188	313	0.00454 (0.0643)	0.00100 (0.0142)
A1□□AJC□□□				1/25	0.636/80 (90.1/80)	2.15 (304)	120	200	0.00418 (0.0592)	0.00064 (0.00906)
A2□□AJA□□□	20	3000	0.0638 (9.03)	1/5	0.255/80 (36.1/80)	0.86 (122)	600	1000	0.00723 (0.102)	0.00175 (0.0248)
A2□□AJB□□□				1/16	0.815/80 (115/80)	2.55*4 (361)	188	313	0.00648 (0.0918)	0.00100 (0.0142)
A2□□AJC□□□				1/25	1.27/80 (180/80)	2.26*4 (320)	120	200	0.00612 (0.0867)	0.00064 (0.00906)
A3□□AJ1□□□	30	3000	0.0955 (13.5)	1/5	0.382/80 (54.1/80)	1.29 (183)	600	1000	0.00917 (0.130)	0.00167 (0.0236)
A3□□AJ2□□□				1/16	1.22/80 (173/80)	3.23*4 (457)	188	313	0.00842 (0.119)	0.00092 (0.0130)
A3□□AJ3□□□				1/25	1.91/80 (270/80)	4.31*4 (610)	120	200	0.0806 (1.14)	0.0731 (1.04)

- * 1. Gear output torque is expressed using the following equation.
(Gear output torque) = (servomotor output torque) × (gear) × (efficiency)
- * 2. Maximum motor speed is up to 5000 min⁻¹ at the shaft.
- * 3. This brake is for holding (de-energization operation) and cannot be used to stop the servomotor.
- * 4. The allowable torque is limited by gear.

3.2 Ratings and Specifications of SGMAJ (3000min⁻¹)

3.2.1 SGMAJ Servomotors Without Gears

(1) Ratings and Specifications

- Time Rating: Continuous
- Vibration Class: 15 μm or below
- Insulation Resistance: 500 VDC, 10 MΩ min.
- Ambient Temperature: 0 to 40°C (32 to 104°F)
- Excitation: Permanent magnet
- Mounting: Flange method
- Thermal Class: B
- Withstand Voltage: 1000 VAC for one minute
- Enclosure: Totally enclosed, self-cooled, IP55 (except for shaft opening)
- Ambient Humidity: 20% to 80% (no condensation)
- Drive Method: Direct drive

Voltage		For 24 VDC		For 48 VDC			
Servomotor Model SGMAJ-		A5C	A8C	A5E	01E	02E	03E
Rated Output *1	kW	50	80	50	100	200	300
Rated Torque *1,*2	N·m	0.159	0.255	0.159	0.318	0.637	0.955
	oz·in *3	22.5	36.1	22.5	45.0	90.2	135
Instantaneous Peak Torque *1	N·m	0.318	0.509	0.318	0.637	1.27	1.91
	oz·in *3	45.0	72.1	45.0	90.2	180	270
Rated Current *1	A _{rms}	2.9	6.1	2.0	2.8	6.4	8.6
Instantaneous Max. Current *1	A _{rms}	5.8	11.8	4.0	5.6	12.6	16.8
Rated Speed *1	min ⁻¹	3000					
Max. Speed *1	min ⁻¹	4500					
Torque Constant	N·m/A _{rms}	0.0599	0.0461	0.0880	0.126	0.109	0.123
	oz·in /A _{rms} *3	8.48	6.53	12.5	17.8	15.4	17.4
Rotor Moment of Inertia J	x10 ⁻⁴ kg·m ²	0.0225	0.0364	0.0225	0.0364	0.106	0.173
	x10 ⁻³ oz·in·s ² *3	0.319	0.515	0.319	0.515	1.50	2.45
Rated Power Rate *1	kW/s	11.3	17.8	11.3	27.9	38.3	52.9
Rated Angular Ac- celeration *1	rad/s ²	70900	70000	70900	87500	60100	55300

- * 1. These items and torque-motor speed characteristics quoted in combination with an SGDJ SERVOPACK are at an armature winding temperature of 100°C (212°F). Other values quoted at 20°C (66.2°F). All values are typical.
- * 2. Rated torques are continuous allowable torque values at 40°C (104°F) with an 250 × 250 × 6 (mm) [10 × 10 × 0.24 (in.)] aluminum plate (heat sink) attached.
- * 3. These values are reference values.

(2) Holding Brake Moment of Inertia

The moment of inertia of the servomotor with holding brake is expressed using the following equation.

(The moment of inertia of the servomotor with holding brake) =
(rotor moment of inertia) + (brake moment inertia)

Servomotor Model SGMAJ-		A5C A5E	A8C	01E	02E	03E
Holding Brake Moment of Inertia J	$\times 10^{-4} \text{ kg}\cdot\text{m}^2$	0.0085			0.058	
	$\times 10^{-3} \text{ oz}\cdot\text{in}\cdot\text{s}^2^*$	0.12			0.82	

* These values are reference values.

(3) Derating Rate for Servomotor With Oil Seal

For a motor with oil seal, use the following derating rate because of the higher friction torque.

Servomotor Model SGMAJ-		A5C A5E	A8C	01E	02E	03E
Derating Rate	(%)	70	80	90		95

(4) Torque-motor Speed Characteristics

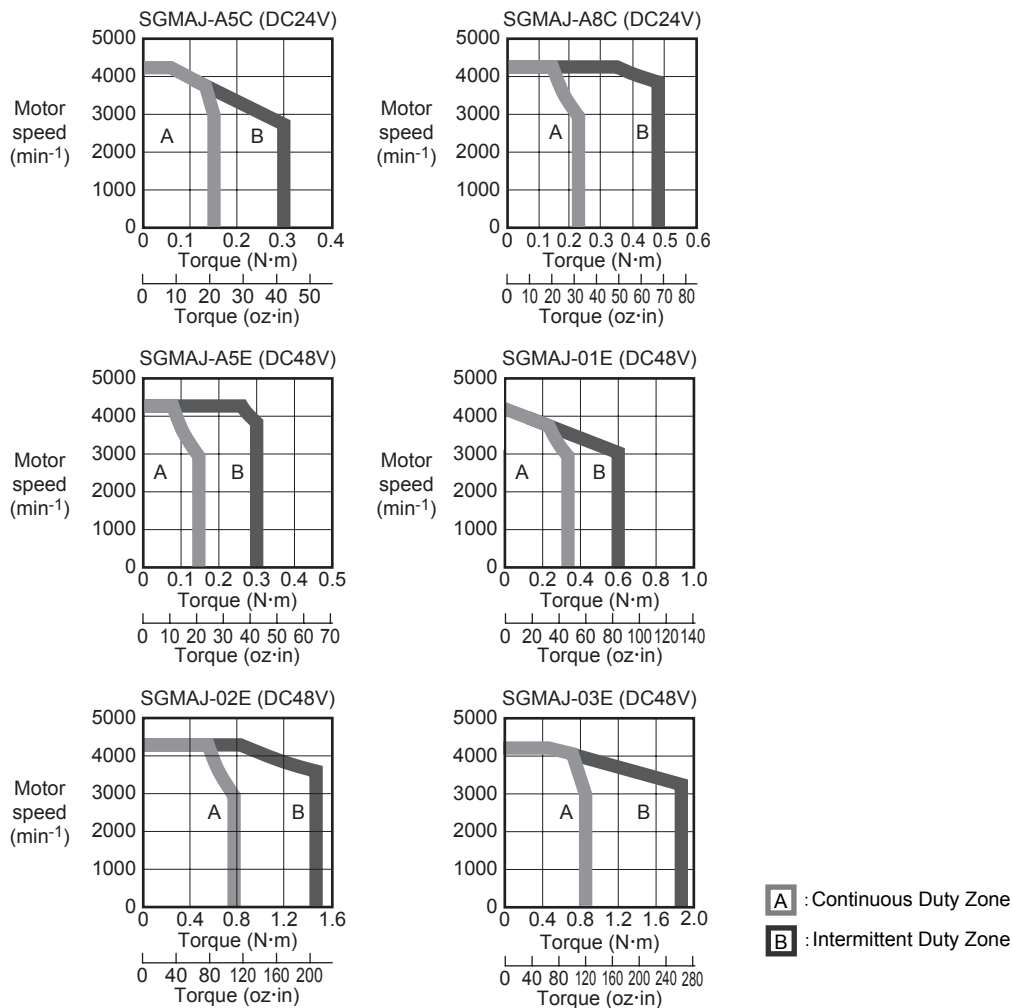

(5) Holding Brake Electrical Specifications

Holding Brake Rated Voltage	Servomotor Model	Servomotor Capacity W	Holding Brake Specifications			
			Capacity W	Holding Torque N·m (oz·in)	Coil Resistance Ω (at 20 °C)	Rated Current A (at 20 °C)
24 VDC	SGMAJ-A5	50	6	0.159 (22.5)	96	0.25
	SGMAJ-A8	80	6	0.255 (36.1)	96	0.25
	SGMAJ-01	100	6	0.318 (45.0)	96	0.25
	SGMAJ-02	200	6.9	0.637 (338)	83.5	0.29
	SGMAJ-03	300	6.9	0.955 (90.2)	83.5	0.29

Note: The holding brake is only used to hold the load and cannot be used to stop the servomotor.

3.2.2 SGMAJ Servomotors With Standard Backlash Gears

- Time Rating: Continuous
- Insulation Resistance: 500 VDC, 10 M Ω min.
- Ambient Temperature: 0 to 40°C (32 to 104°F)
- Excitation: Permanent magnet
- Mounting: Flange method
- Gear Mechanism: Planetary gear mechanism
- Thermal Class: B
- Withstand Voltage:
100V, 200V Servomotors: 1500 VAC for one minute
400V Servomotors: 1800 VAC for one minute
- Enclosure: Totally enclosed, self-cooled, IP55 (except for shaft opening)
- Ambient Humidity: 20% to 80% (no condensation)
- Drive Method: Direct drive
- Backlash: 15 to 20 min max.
- Gear Rotation Direction: Same direction as servomotor

Servomotor Model SGMAJ-	Servomotor			Gear Output					Moment of Inertia J $\times 10^{-4}$ kg·m ² ($\times 10^{-3}$ oz·in·s ²)	
	Output W	Rated Speed min ⁻¹	Rated Torque N·m (oz·in)	Gear Ratio	Rated Torque/ Efficiency* ² N·m/% (oz·in/%)	Instantaneous Peak Torque N·m (oz·in)	Rated Speed min ⁻¹	Max. Speed* ¹ min ⁻¹	Motor + Gears	Gears
A5□□AJ1□□	50	3000	0.159 (22.5)	1/5	0.557/70 (78.9/70)	1.92 (272)	600	800	0.050 (0.708)	0.028 (0.396)
A5□□AJ3□□				3/31	1.15/70 (163/70)	3.95 (559)	290	387	0.040 (0.566)	0.018 (0.255)
A5□□AJC□□				1/21	2.67/80 (378/80)	9.07 (1284)	143	190	0.036 (0.510)	0.014 (0.198)
A5□□AJ7□□				1/33	4.20/80 (595/80)	14.3 (2025)	91	121	0.032 (0.453)	0.010 (0.142)
A8C□AJ1□□	80		0.255 (36.1)	1/5	1.02/80 (144/80)	3.44 (487)	600	800	0.099 (1.40)	0.063 (0.892)
A8C□AJ3□□				3/31	2.10/80 (297/80)	7.11 (1007)	290	387	0.054 (0.765)	0.018 (0.255)
A8C□AJC□□				1/21	4.27/80 (605/80)	14.5 (2053)	143	190	0.071 (1.01)	0.035 (0.496)
A8C□AJ7□□				1/33	6.72/80 (952/80)	22.7 (3214)	91	121	0.057 (0.807)	0.021 (0.297)
01E□AJ1□□	100		0.318 (45.0)	1/5	1.27/80 (180/80)	4.32 (612)	600	800	0.099 (1.40)	0.063 (0.892)
01E□AJ3□□				3/31	2.63/80 (372/80)	8.88 (1257)	290	387	0.054 (0.765)	0.018 (0.255)
01E□AJC□□				1/21	5.34/80 (756/80)	18.1 (2563)	143	190	0.071 (1.01)	0.035 (0.496)
01E□AJ7□□				1/33	8.40/80 (1189/80)	28.4 (4021)	91	121	0.057 (0.807)	0.021 (0.297)

(cont'd)

Servomotor Model SGMAJ-	Servomotor			Gear Output					Moment of Inertia J ×10 ⁻⁴ kg·m ² (× 10 ⁻³ oz·in·s ²)	
	Output W	Rated Speed min ⁻¹	Rated Torque N·m (oz·in)	Gear Ratio	Rated Torque/ Effi- ciency* ² N·m/% (oz·in/%)	Instanta- neous Peak Torque N·m (oz·in)	Rated Speed min ⁻¹	Max. Speed* ¹ min ⁻¹	Motor + Gears	Gears
02E□AJ1□□	200	3000	0.637 (90.2)	1/5	2.55/80 (361/80)	8.6 (1218)	600	800	0.299 (4.23)	0.193 (2.73)
02E□AJ3□□				3/31	5.27/80 (746/80)	17.8 (2520)	290	387	0.196 (2.78)	0.090 (1.27)
02E□AJC□□				1/21	10.7/80 (1515/80)	36.1 (5112)	143	190	0.211 (2.99)	0.105 (1.49)
02E□AJ7□□				1/33	16.8/80 (2379/80)	56.7 (8029)	91	121	0.181 (2.56)	0.075 (1.06)
03E□AJ1□□	300	3000	0.955 (135)	1/5	3.82/80 (541/80)	17.2 (2436)	600	800	0.366 (5.18)	0.193 (2.73)
03E□AJ3□□				3/31	7.89/80 (1117/80)	35.5 (5027)	290	387	0.353 (5.00)	0.180 (2.55)
03E□AJC□□				1/21	16.0/80 (2266/80)	72.2 (10224)	143	190	0.403 (5.71)	0.230 (3.26)
03E□AJ7□□				1/33	25.2/80 (3568/80)	113.0 (16001)	91	121	0.338 (4.79)	0.165 (2.34)

* 1. Maximum motor speed is up to 4000 min⁻¹ at the shaft.

* 2. Gear output torque is expressed using the following equation.

* 3. (Gear output torque) = (servomotor output torque) × ($\frac{1}{\text{gear ratio}}$) × (efficiency)

3.2.3 SGMAJ Servomotors With Low-backlash Gears

- Time Rating: Continuous
- Insulation Resistance: 500 VDC, 10 M Ω min.
- Ambient Temperature: 0 to 40°C (32 to 104°F)
- Excitation: Permanent magnet
- Mounting: Flange method
- Gear Mechanism: Planetary gear mechanism
- Thermal Class: B
- Withstand Voltage:
100V, 200V Servomotors: 1500 VAC for one minute
400V Servomotors: 1800 VAC for one minute
- Enclosure: Totally enclosed, self-cooled, IP55 (except for shaft opening)
- Ambient Humidity: 20% to 80% (no condensation)
- Drive Method: Direct drive
- Backlash: 3 min max.
- Gear Rotation Direction: Same direction as servomotor

Servomotor Model SGMAJ-	Servomotor			Gear Output					Moment of Inertia J $\times 10^{-4}$ kg·m ² ($\times 10^{-3}$ oz·in·s ²)	
	Output W	Rated Speed min ⁻¹	Rated Torque N·m (oz·in)	Gear Ratio	Rated Torque/Efficiency*2 N·m/% (oz·in/%)	Instantaneous Peak Torque N·m (oz·in)	Rated Speed min ⁻¹	Max. Speed*1 min ⁻¹	Motor + Gears	Gears
A5□□AH1□□	50	3000	0.159 (22.5)	1/5	0.557/70 (78.9/70)	1.92 (272)	600	800	0.058 (0.821)	0.036 (0.510)
A5□□AH2□□				1/9	1.00/70 (142/70)	3.89 (551)	333	444	0.055 (0.779)	0.033 (0.467)
A5□□AHC□□				1/21	2.67/80 (378/80)	9.12 (1291)	143	190	0.040 (0.566)	0.018 (0.255)
A5□□AH7□□				1/33	4.2/80 (595/80)	14.3 (2025)	91	121	0.035 (0.496)	0.013 (0.184)
A8C□AH1□□	80		0.255 (36.1)	1/5	1.02/80 (144/80)	3.06 (433)	600	800	0.114 (1.61)	0.078 (1.10)
A8C□AHB□□				1/11	2.24/80 (317/80)	6.73 (953)	273	363	0.084 (1.19)	0.048 (0.680)
A8C□AHC□□				1/21	4.27/80 (605/80)	14.5 (2053)	143	190	0.079 (1.19)	0.043 (0.609)
A8C□AH7□□				1/33	6.72/80 (952/80)	22.7 (3214)	91	121	0.069 (0.977)	0.033 (0.467)
01E□AH1□□	100		0.318 (45.0)	1/5	1.27/80 (180/80)	4.34 (615)	600	800	0.114 (1.61)	0.078 (1.10)
01E□AHB□□				1/11	2.8/80 (396/80)	9.55 (1352)	273	363	0.084 (1.19)	0.048 (0.680)
01E□AHC□□				1/21	5.34/80 (756/80)	18.2 (2577)	143	190	0.079 (1.19)	0.043 (0.609)
01E□AH7□□				1/33	8.4/80 (1189/80)	28.7*3 (4064)	91	121	0.069 (0.977)	0.033 (0.467)

(cont'd)

Servomotor Model SGMAJ-	Servomotor			Gear Output					Moment of Inertia J ×10 ⁻⁴ kg·m ² (×10 ⁻³ oz·in·s ²)	
	Out-put W	Rated Speed min ⁻¹	Rated Torque N·m (oz·in)	Gear Ratio	Rated Torque/Effi- ciency* ² N·m/% (oz·in/%)	Instanta- neous Peak Torque N·m (oz·in)	Rated Speed min ⁻¹	Max. Speed* ¹ min ⁻¹	Motor + Gears	Gears
02E□AH1□□	200	3000	0.637 (90.2)	1/5	2.55/80 (361/80)	8.4 (1189)	600	800	0.441 (6.24)	0.335 (4.74)
02E□AHB□□				1/11	5.96/85 (844/85)	19.3 (2733)	273	363	0.191 (2.70)	0.085 (1.20)
02E□AHC□□				1/21	11.4/85 (1614/85)	37.3 (5282)	143	190	0.216 (3.06)	0.110 (1.56)
02E□AH7□□				1/33	17.9/85 (2535/85)	58.6* ³ (8298)	91	121	0.171 (2.42)	0.065 (0.920)
03E□AH1□□	300	3000	0.955 (135)	1/5	4.06/85 (575/85)	17.2 (2436)	600	800	0.508 (7.19)	0.335 (4.74)
03E□AHB□□				1/11	8.93/85 (1264/85)	35* ³ (4956)	273	363	0.368 (5.21)	0.195 (0.276)
03E□AHC□□				1/21	17.0/85 (2407/85)	72.2 (10224)	143	190	0.368 (5.21)	0.195 (0.276)
03E□AH7□□				1/33	25.2/80 (3568/80)	93* ³ (13169)	91	121	0.346 (4.90)	0.173 (2.45)

* 1. Maximum motor speed is up to 4000 min⁻¹ at the shaft.

* 2. Gear output torque is expressed using the following equation.

$$(\text{Gear output torque}) = (\text{servomotor output torque}) \times \left(\frac{1}{\text{gear ratio}}\right) \times (\text{efficiency})$$

* 3. The instantaneous peak torque values indicated with *3 are limited by the gear, so use the following servomotor instantaneous peak torque. In this case, set torque limit parameters Pn402 and 403 for the SERVOPACK at 250%.

3.3 Mechanical Specifications of SGMMJ and SGMAJ Servomotors

3.3.1 Precautions on Servomotor Installation

Servomotors can be installed either horizontally or vertically.

The service life of the servomotor will be shortened or unexpected problems will occur if the servomotor is installed incorrectly or in an inappropriate location. Always observe the following installation instructions.

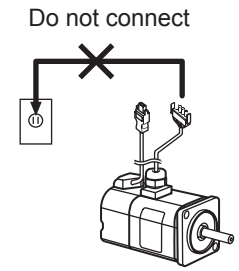
 CAUTION	
<ul style="list-style-type: none"> Do not connect the servomotor directly to a commercial power line. This will damage the servomotor. The servomotor cannot operate without the proper SERVOPACK. 	<p>Do not connect</p> 

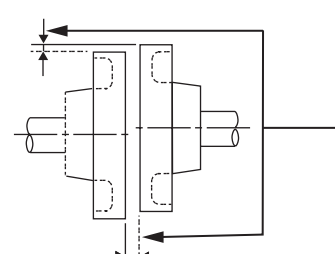
Storage Temperature and Humidity	Store the servomotor within the following temperature range if it is stored with the power cable disconnected. Ambient temperature during storage: -20 to 60°C (-4 to 140°F) Ambient humidity during storage: 80%RH or less (with no condensation)
Installation Site	Servomotors are designed for indoor use. Install the servomotor in environments that satisfy the following conditions. <ul style="list-style-type: none"> Free of corrosive or explosive gases. Well-ventilated and free of dust and moisture. Ambient temperature of 0 to 40°C (32 to 104° F) Relative humidity of 20 to 80% with no condensation. Facilitates inspection and cleaning
Alignment	<div style="display: flex; justify-content: space-between;"> <div style="width: 45%;"> <p>Alignment Accuracy</p> <div style="border: 1px solid black; padding: 5px; margin-bottom: 10px;"> Measure this distance at four different positions on the circumference. The difference between the maximum and minimum measurements must be 0.03 mm (0.0012 in) or less. (Turn together with coupling.) </div>  </div> <div style="width: 50%;"> <p>Align the shaft of the servomotor with the shaft of the equipment, and then couple the shafts. Install the servomotor so that alignment accuracy falls within the range described on the left.</p> <p>Vibration may occur and damage the bearings and encoders if the shafts are not correctly aligned.</p> </div> </div>
Orientation	Servomotors can be installed either horizontally or vertically.

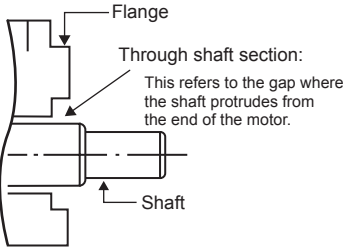
Handling Oil and Water		<p>If the servomotor is used in a location that is subject to water drops, make sure of the servomotor protective specifications (except for through shaft section).</p> <p>If the servomotor is used in a location that is subject to water or oil mist, use a servomotor with an oil seal to seal the through shaft section.</p> <p>Precautions on Using Servomotor With Oil Seal</p> <ul style="list-style-type: none"> • The oil surface must be under the oil seal lip. • Use an oil seal in favorably lubricated condition. • When using a servomotor with its shaft pointed upward, be sure that oil will not stay in the oil seal lips.
Cable Stress	<p>Make sure there are no bends or tension on the power lines. Especially be careful to wire signal line cables so that they are not subject to stress because the core wires are very thin at only 0.2 to 0.3 mm (0.0079 to 0.012 in).</p>	
Connectors	<p>Observe the following precautions:</p> <ul style="list-style-type: none"> • Make sure there is no foreign matters such as dust and metal chips in the connector before connecting. • When the connectors are connected to the motor, be sure to connect the end of servomotor main circuit cables before connecting the encoder cable's end. If the encoder cable's end is connected first, the encoder may be damaged because of the voltage differences between FGs. • Make sure of the pin arrangement. • Do not apply shock to resin connectors. Otherwise, they may be damaged. • When handling a servomotor with its cables connected, hold the servomotor or the connectors. Otherwise, the cables will be damaged. • When bending cables are used, wiring must be performed so that excessive stress will not be applied to the connector section. Failure to observe this caution may damage the connector. 	

IMPORTANT

1. Before starting installation, thoroughly remove the anticorrosive paint that coats the end of the motor shaft.

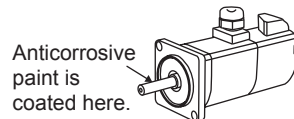

2. Vibration from improper alignment of shafts will damage the bearings.
3. Do not allow direct impact to be applied to the shafts when installing the coupling as the encoder mounted on the opposite end of the shaft may be damaged.

3.3.2 Mechanical Characteristics of SGMMJ Servomotors

(1) Mechanical Tolerance

This section describes the mechanical specifications of SGMMJ servomotor.

Tolerance T. I. R. (Total Indicator Reading)		Standard	With gears	Reference Diagram
A	Perpendicularity between the flange face and output shaft	0.04 mm (0.00157 in)	0.06 mm (0.00236 in)	
B	Mating concentricity of the flange O.D.	0.04 mm (0.00157 in)	0.05 mm (0.00197 in)	
C	Run-out at the end of the shaft	0.02 mm (0.000787 in)	0.04 mm (0.00157 in)	

(2) Direction of Servomotor Rotation

Positive rotation of the servomotor is counterclockwise when viewed from the load.

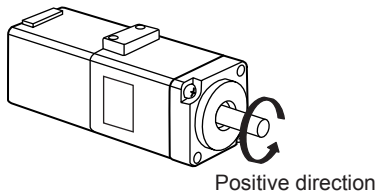

(3) Impact Resistance

Mount the servomotor with the axis horizontal. The servomotor will withstand the following vertical impacts:

- Impact acceleration: 490 m/s²
- Impact occurrences: 2

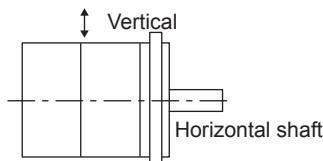

IMPORTANT

Because the detector of the servomotor is installed on the shaft end opposite the load, do not apply shock to the shaft. Failure to observe this caution may result in damage to the product.

(4) Vibration Resistance

Mount the servomotor with the axis horizontal. The servomotor will withstand the following vibration acceleration in three directions: Vertical, side to side, and front to back.

Vibration acceleration at flange: 49 m/s²

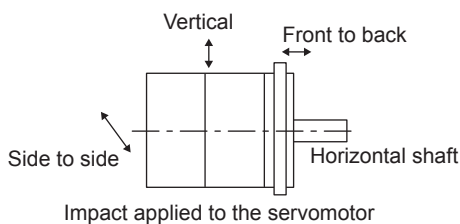

(5) Vibration Class

The vibration class for the servomotors at rated motor speed is shown below.

Vibration class: 15 μm or below

Position for measuring vibration

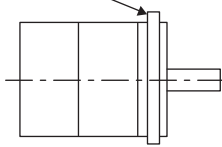

(6) Protective Structure

The standard protection class for the protective structure is IP55 except for shaft opening.

3.3.3 Mechanical Characteristics of SGMAJ Servomotors

(1) Mechanical Tolerance

The following table shows tolerances for the servomotor's output shaft and installation area. For more details on tolerances, refer to the dimensional drawing of the individual servomotor.

Tolerance T. I. R. (Total Indicator Reading)		Standard	With gears	Reference Diagram
A	Perpendicularity between the flange face and output shaft	0.04 mm (0.00157 in)	0.06 mm (0.00236 in)	
B	Mating concentricity of the flange O.D.	0.04 mm (0.00157 in)	0.05 mm (0.00197 in)	
C	Run-out at the end of the shaft	0.02 mm (0.000787 in)	0.04 mm (0.00157 in)	

(2) Direction of Servomotor Rotation

Positive rotation of the servomotor is counterclockwise when viewed from the load. (Same as for servomotors with gears.)

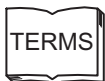
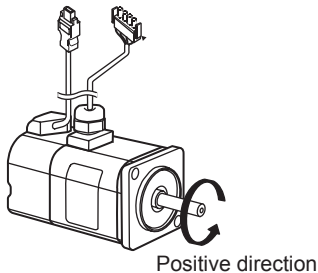

Vibration Class

A vibration class of 15 μm or below indicates a total vibration amplitude of 15 μm maximum on the servomotor during rated rotation.

(3) Impact Resistance

Mount the servomotor with the axis horizontal. The servomotor will withstand the following vertical impacts:

- Impact acceleration: 490 m/s^2
- Impact occurrences: 2

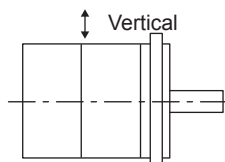

(4) Vibration Resistance

Mount the servomotor with the axis horizontal. The servomotor will withstand the following vibration acceleration in three directions: Vertical, side to side, and front to back.

Vibration acceleration at flange: 49 m/s^2

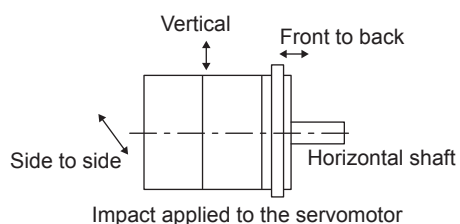

(5) Vibration Class

The vibration class for the servomotors at rated motor speed is $15 \mu\text{m}$ or below.

(6) Protective Structure

The standard protection class for the protective structure is IP55 except for shaft opening.

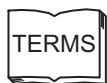

Vibration Class

A vibration class of $15 \mu\text{m}$ or below indicates a total vibration amplitude of $15 \mu\text{m}$ maximum on the servomotor during rated rotation.

3.4 Terms and Data for Servomotors With Gears

(1) Terms for Servomotors With Standard Backlash Gears and Low-backlash Gears

Terminology for Servomotors with Gears

Item	Measurement Method/Definition	Typical Value	
		Standard Backlash Gears	Low-backlash Gears
Rated Input Motor Speed (min^{-1})	—	3000	3000
Max. Allowable Input Motor Speed (min^{-1})	—	4000	4000
Rated Torque (N·m)	The rated output torque of the motor is the gear input torque. The rated torque is this value multiplied by the inverse of the gear ratio and efficiency.	—	—
Lost Motion (arc-min)*	Angular difference in the screw with a $\pm 5\%$ rated torque load. (Maximum value at any four positions during output.)	15 max.	3 max.
Torsion Rigidity (arc-min)*	Highest torsion angle value on one side with a \pm rated torque load	22 max.	10 max.
Angular Transmission Error Accuracy (arc-min)	Difference in absolute accuracy for one rotation under load and no-load conditions during output.	10 max.	6 max.

* See the following graph for lost motion and torsion rigidity.

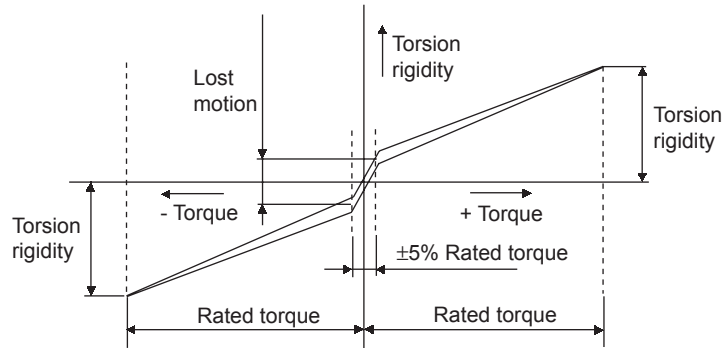

(2) Noise Data

The following noise data for a servomotor with a gear is for reference only and may slightly vary with the capacity and gear ratio of the servomotor.

Measurement Conditions:

- Scale A: 50 cm (19.7 in)
- Ground Noise: 28 dB

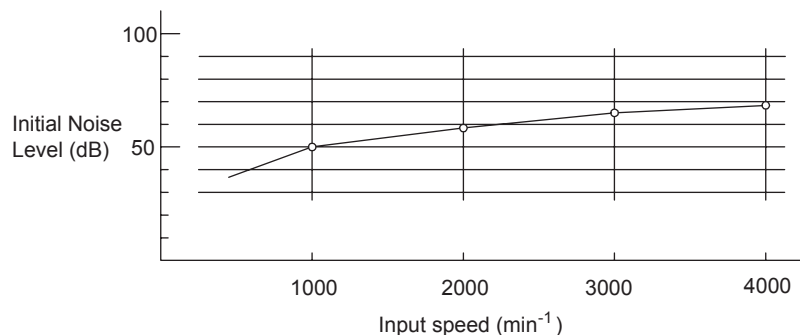

(3) Efficiency

The output torque and motor speed produce the following trends in efficiency. The values in the tables, Ratings and Specifications of SGMMJ and SGMAJ Servomotors with Gears, are at the rated motor torque and rated motor speed (3000 min^{-1}).

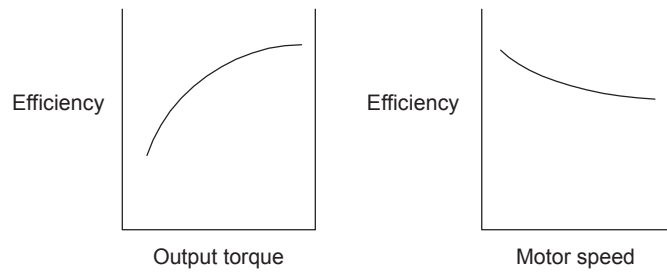

3.5 Dimensional Drawings of SGMMJ Servomotors (3000min⁻¹)

3.5.1 SGMMJ Servomotors (3000min⁻¹) Standard and Without Brakes

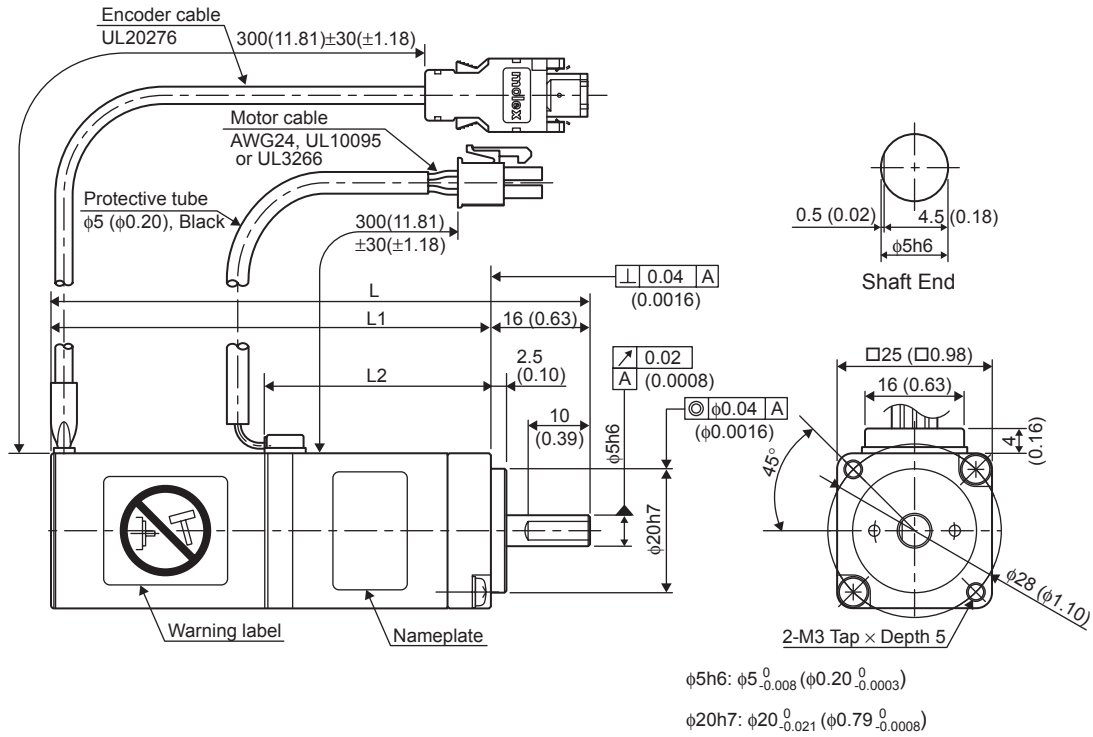

Units: mm (in)

Model SGMMJ-	L	L1	L2	Flat	Approx. Mass kg (lb)	Allowable Radial Load N (lbf)	Allowable Thrust Load N (lbf)
A1□□A21□	77	61	26.5	Not applied	130	34.3	14.7 (3.30)
A1□□AA1□	(3.03)	(2.40)	(1.04)	Applied	(287)	(7.71)	
A2□□A21□	87	71	36.5	Not applied	170	44.1 (9.91)	
A2□□AA1□	(3.43)	(2.80)	(1.44)	Applied	(375)		
A3□□A21□	97	81	46.5	Not applied	210	44.1 (9.91)	
A3□□AA1□	(3.82)	(3.19)	(1.83)	Applied	(463)		

3.5.2 SGMMJ Servomotors (3000min⁻¹) Standard and With Brakes

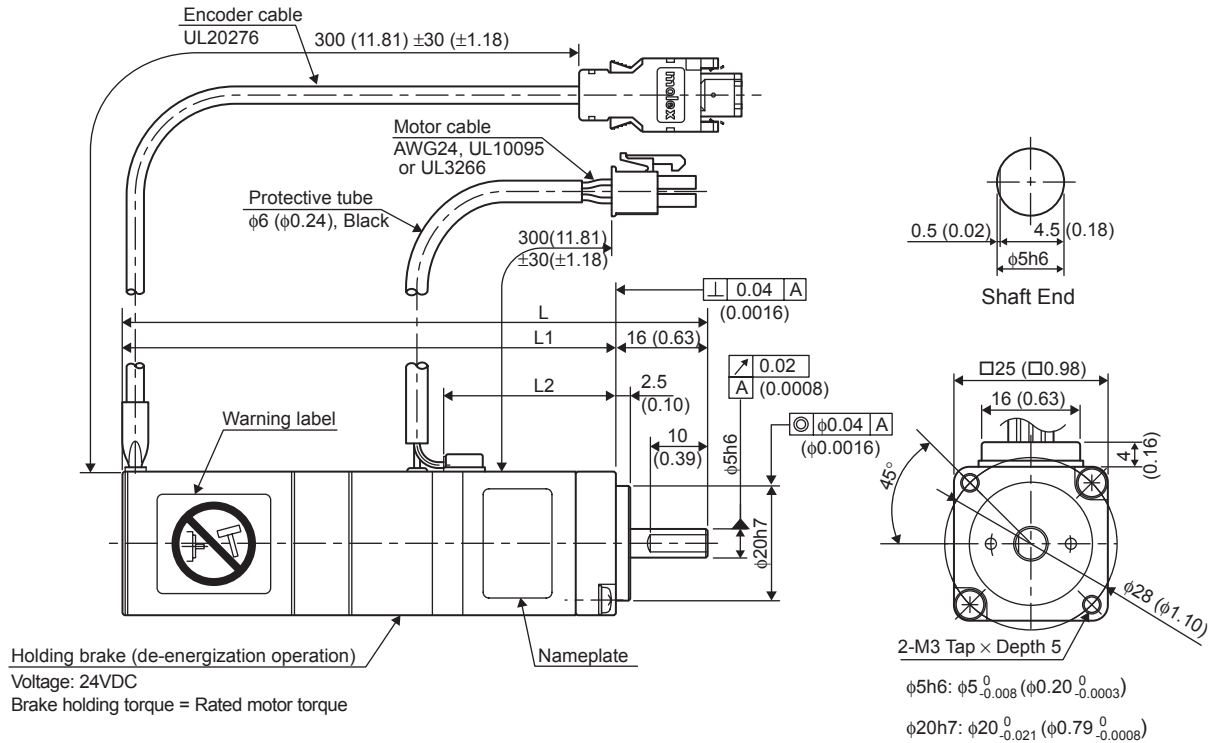

Units: mm (in)

Model SGMMJ-	L	L1	L2	Flat	Approx. Mass kg (lb)	Allowable Radial Load N (lbf)	Allowable Thrust Load N (lbf)
A1□□A2C□	101.5	85.5	26.5	Not applied	215	34.3	14.7 (3.30)
A1□□AAC□	(3.40)	(3.37)	(1.04)	Applied	(474)	(7.71)	
A2□□A2C□	115.5	99.5	36.5	Not applied	270	44.1 (9.91)	
A2□□AAC□	(4.55)	(3.92)	(1.44)	Applied	(595)		
A3□□A2C□	125.5	109.5	46.5	Not applied	310	44.1 (9.91)	
A3□□AAC□	(4.94)	(4.31)	(1.83)	Applied	(683)		

Note: The electromagnetic brake is only used to hold the position and cannot be used to stop the servomotor.

3.5.3 SGMMJ Servomotor (3000min⁻¹) With Gears and Without Brakes

(1) 10 W, 20 W

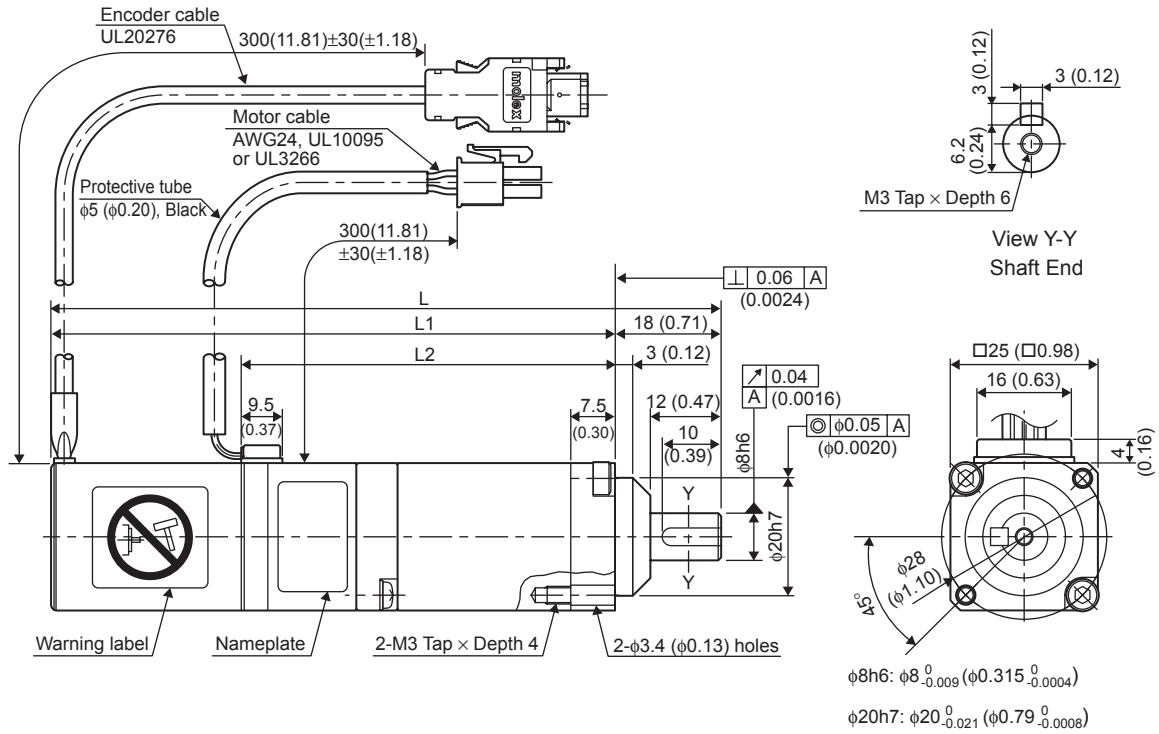

Units: mm (in)

Model SGMMJ-	L	L1	L2	Key	Tap × Depth	Approx. Mass kg (lb)	Allowable Radial Load N (lbf)	Allowable Thrust Load N (lbf)
A1□□AJA21□	113.5 (4.47)	95.5 (3.76)	61 (2.40)	None	No tap	240 (529)	52 (12)	47 (11)
A1□□AJA61□	124 (4.88)	106 (4.17)	71.5 (2.81)	Attached	M3 × 6L	275 (606)	76 (17)	
A1□□AJB21□				None	No tap	275 (606)	89 (20)	
A2□□AJB61□	123.5 (4.86)	105.5 (4.15)	71 (2.80)	Attached	M3 × 6L	280 (617)	52 (12)	
A2□□AJC21□	134 (5.28)	116 (4.57)	81.5 (3.21)	None	No tap	315 (694)	76 (17)	
A2□□AJC61□				Attached	M3 × 6L	315 (694)	89 (20)	

Note: The key slot conforms to the standard, JIS B 1301-1975 (fine class) and the parallel key is attached to it.

3.5.3 SGMMJ Servomotor (3000min⁻¹) With Gears and Without Brakes

(2) 30 W

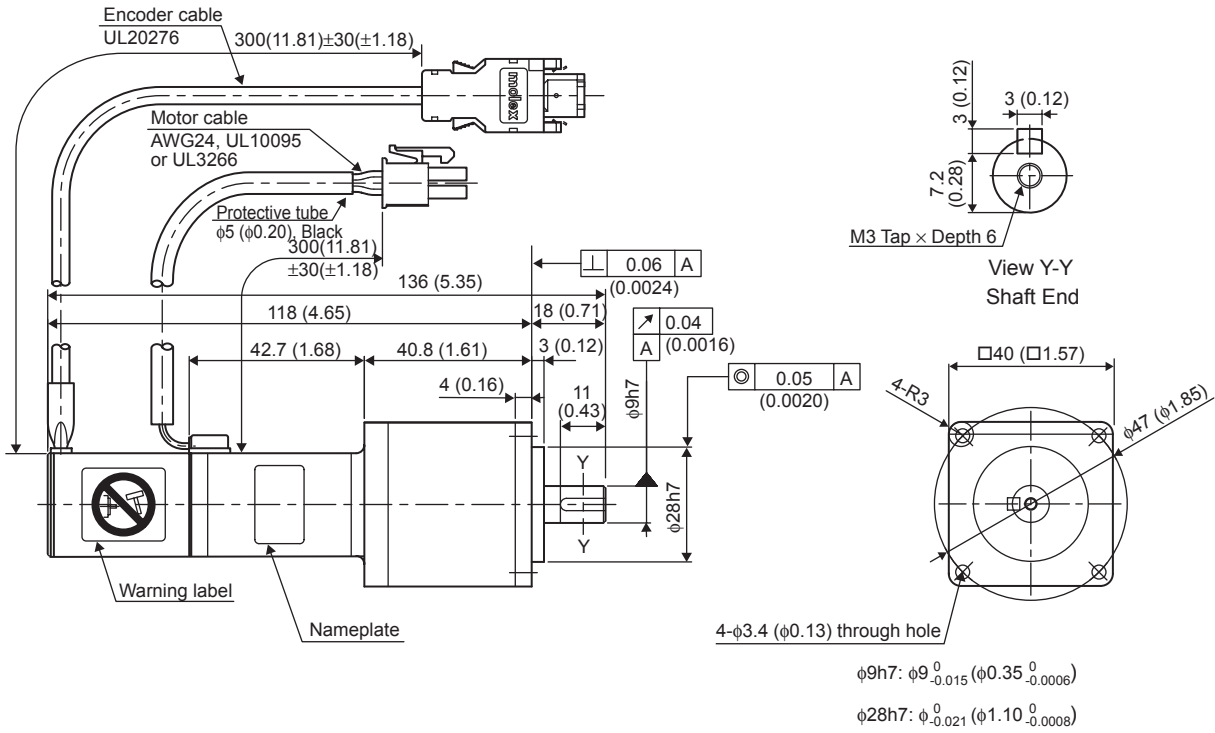

Units: mm (in)

Model SGMMJ-	Key	Tap × Depth	Approx. Mass kg (lb)	Allowable Radial Load N (lbf)	Allowable Thrust Load N (lbf)
A3□□AJ12□	None	No tap	410 (904)	69	59 (13)
A3□□AJ16□	Attached	M3 × 6L		(16)	
A3□□AJ22□	None	No tap		147	
A3□□AJ26□	Attached	M3 × 6L		(33)	
A3□□AJ32□	None	No tap		186	
A3□□AJ36□	Attached	M3 × 6L		(42)	

Note: The key slot conforms to the standard, JIS B 1301-1975 (fine class) and the parallel key is attached to it.

3.5.4 SGMMJ Servomotors (3000min⁻¹) With Gears and Brakes

(1) 10 W, 20 W

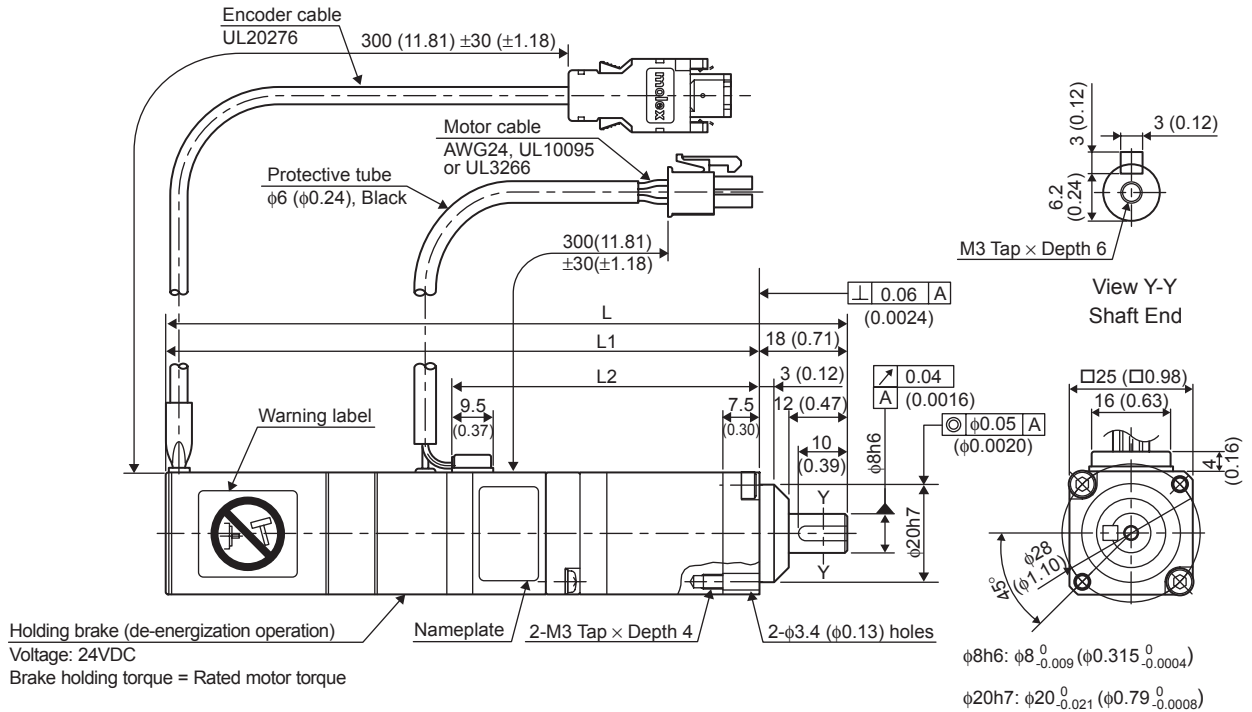

3

Units: mm (in)

Model SGMMJ-	L	L1	L2	Key	Tap × Depth	Approx. Mass kg (lb)	Allowable Radial Load N (lbf)	Allowable Thrust Load N (lbf)
A1□□AJA2C□	142 (5.59)	124 (4.88)	61 (2.40)	None	No tap	325 (717)	52 (12)	47 (11)
A1□□AJA6C□	152.5 (6.00)	134.5 (5.30)	71.5 (2.82)	Attached	M3 × 6L	360 (794)	76 (17)	
A1□□AJB2C□				None	No tap	360 (794)	89 (20)	
A2□□AJB6C□	152 (5.98)	134 (5.28)	71 (2.80)	Attached	M3 × 6L	380 (838)	52 (12)	
A2□□AJC2C□	162.5 (6.40)	144.5 (5.69)	81.5 (3.21)	None	No tap	415 (915)	76 (17)	
A2□□AJC6C□				Attached	M3 × 6L	415 (915)	89 (20)	

Note: The key slot conforms to the standard, JIS B 1301-1975 (fine class) and the parallel key is attached to it.

3.5.4 SGMMJ Servomotors (3000min⁻¹) With Gears and Brakes

(2) 30 W

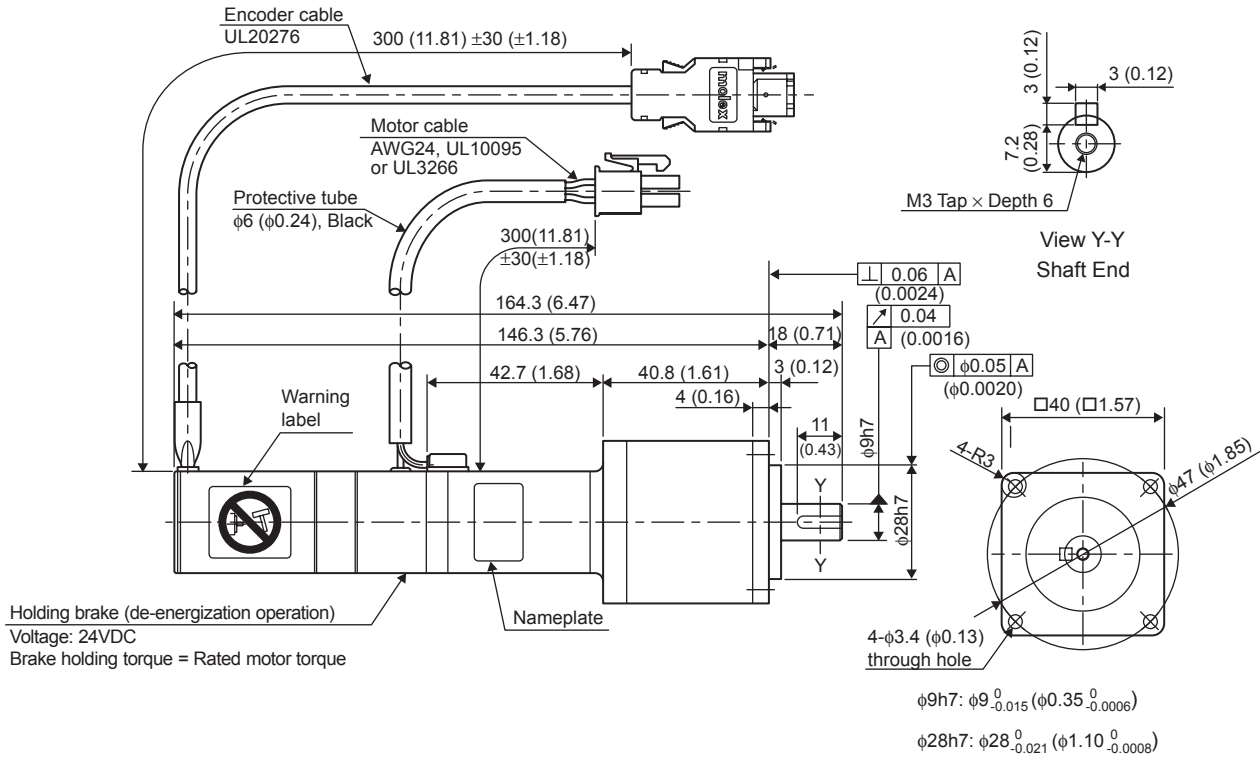

Units: mm (in)

Model SGMMJ-	Tap × Depth	Approx. Mass kg (lb)	Allowable Radial Load N (lbf)	Allowable Thrust Load N (lbf)
A3□□AJ12C□	No tap	555 (1224)	69 (16)	59 (13)
A3□□AJ16C□	M3 × 6L			
A3□□AJ22C□	No tap		147 (33)	
A3□□AJ26C□	M3 × 6L			
A3□□AJ32C□	No tap		186 (42)	
A3□□AJ36C□	M3 × 6L			

Note: 1. The key slot conforms to the standard, JIS B 1301-1975 (fine class) and the parallel key is attached to it.

2. The electromagnetic brake is only used to hold the position and cannot be used to stop the servo-motor.

3.6 Dimensional Drawings of SGMAJ Servomotors (3000 min⁻¹)

3.6.1 SGMAJ Servomotors (3000 min⁻¹) Without Gears

(1) 50 W, 80 W, 100 W

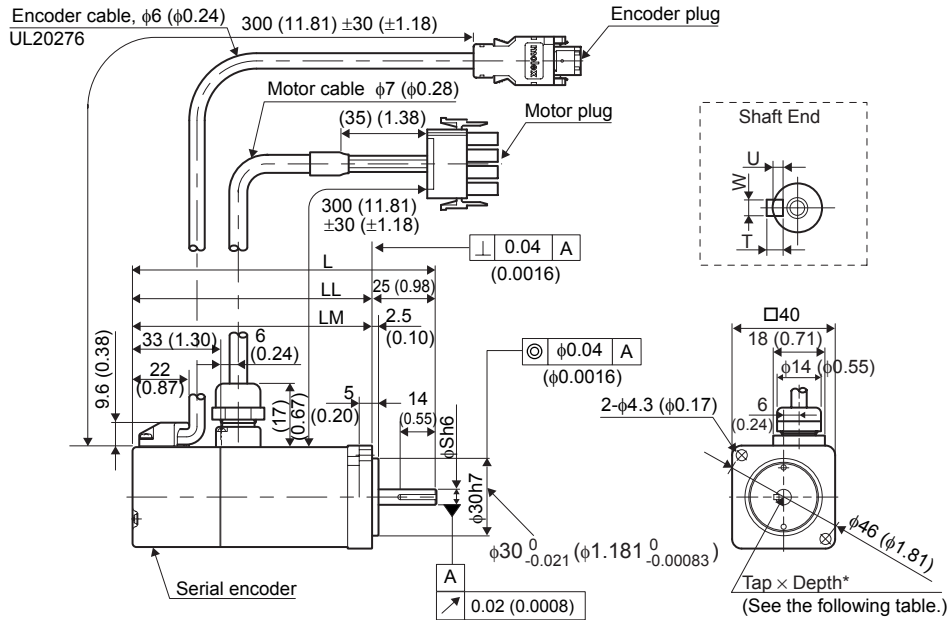

Units: mm (in)

Model SGMAJ-	L	LL	LM	Tap × Depth*	U	W	T	Approx. Mass kg (lb)	Allowable Radial Load N (lbf)	Allowable Thrust Load N (lbf)
A5□□A21	102.0 (4.02)	77.0 (3.03)	44.0 (1.73)	No tap	No key			0.4 (0.88)	68 (15)	54 (12)
A5□□A41					1.2 (0.047)	2 (0.079)	2 (0.079)			
A5□□A61					M2.5 × 5L					
A8C□A21	119.5 (4.70)	94.5 (3.72)	61.5 (2.45)	No tap	No key			0.5 (1.1)	78 (18)	54 (12)
A8C□A41					1.8 (0.071)	3 (0.12)	3 (0.12)			
A8C□A61					M3 × 6L					
01□□A21	119.5 (4.70)	94.5 (3.72)	61.5 (2.42)	No tap	No key			0.5 (1.1)	78 (18)	54 (12)
01□□A41					1.8 (0.071)	3 (0.12)	3 (0.12)			
01□□A61					M3 × 6L					



- The dimensions for L and LL of a servomotor incorporating an encoder with super-capacitor (model: SGMAJ-□□□□4) are as shown below.
SGMAJ-A5, A8, and 01: L-dimension +12 mm (0.47 in), LL-dimension +12 mm (0.47 in)
- The working point of the SGMAJ servomotor radial load is at the position of minus 5 mm from the shaft end.

3.6.1 SGMAJ Servomotors (3000 min⁻¹) Without Gears

• Dimensional Tolerances

Units: mm (in)

Model SGMAJ-	Shaft-end Dimensions	
	S	
A5□□A21	6 ⁰ _{-0.008}	(0.236 ⁰ _{-0.0003})
A5□□A41		
A5□□A61		
A8C□A21	8 ⁰ _{-0.009}	(0.315 ⁰ _{-0.0004})
A8C□A41		
A8C□A61		
01□□A21	8 ⁰ _{-0.009}	(0.315 ⁰ _{-0.0004})
01□□A41		
01□□A61		

(2) 200 W, 300 W

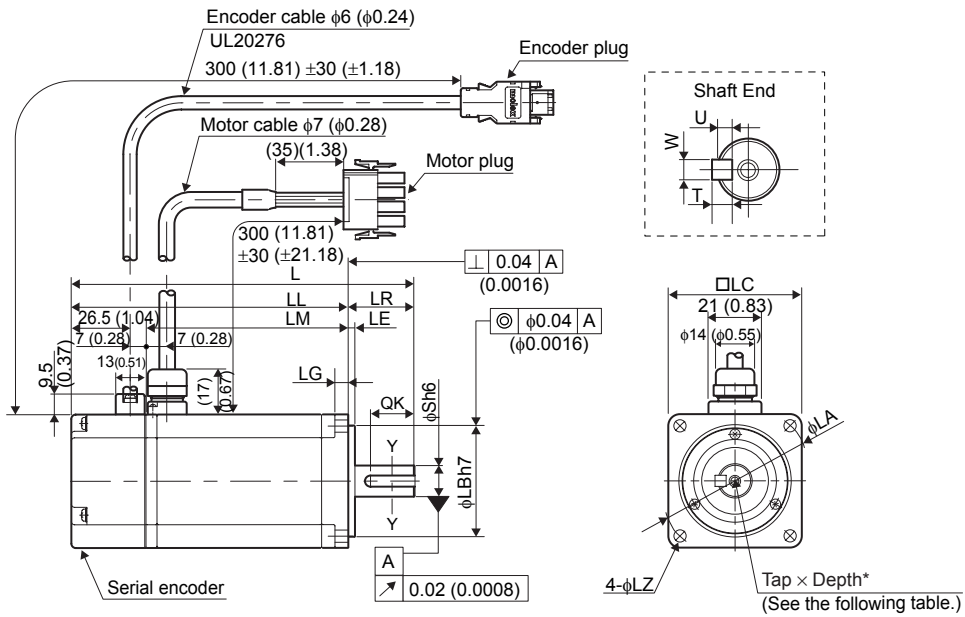

Units: mm (in)

Model SGMAJ-	L	LL	LM	LR	LE	LG	LA	LC	LZ
02E□A21	126.5 (4.98)	96.5 (3.80)	63 (2.48)	30 (1.18)	3 (0.12)	6 (0.24)	70 (2.76)	60 (2.36)	5.5 (0.22)
02E□A41									
02E□A61									
03E□A21	154.5 (6.08)	124.5 (4.90)	91 (3.58)	30 (1.18)	3 (0.12)	6 (0.24)	70 (2.76)	60 (2.36)	5.5 (0.22)
03E□A41									
03E□A61									

Units: mm (in)

Model SGMAJ-	Tap× Depth*	QK	U	W	T	Approx. Mass kg (lb)	Allowable Radial Load N (lbf)	Allowable Thrust Load N (lbf)
02E□A21	No tap	No key				1.1 (2.4)	245 (55)	74 (17)
02E□A41		20 (0.79)	3 (0.12)	5 (0.20)	5 (0.20)			
02E□A61	M5×8L							
03E□A21	No tap	No key				1.7 (3.7)	245 (55)	74 (17)
03E□A41		20 (0.79)	3 (0.12)	5 (0.20)	5 (0.20)			
03E□A61	M5×8L							



- The dimensions for L and LL of a servomotor incorporating an encoder with super-capacitor (model: SGMAJ-□□□4) are as shown below.

SGMAJ-02 and 03: L-dimension + 8.2 mm (0.32 in), LL-dimension +8.2 mm (0.32 in).

- The working point of the SGMAJ servomotor radial load is at the position of minus 5 mm from the shaft end.

• Dimensional Tolerances

Units: mm (in)

Model SGMAJ-	Shaft-end Dimensions	Flange Face Dimensions
	S	LB
02E□A21	$14 \begin{matrix} 0 \\ -0.011 \end{matrix} \left(0.5512 \begin{matrix} 0 \\ -0.00043 \end{matrix} \right)$	$50 \begin{matrix} 0 \\ -0.025 \end{matrix} \left(1.9685 \begin{matrix} 0 \\ -0.00098 \end{matrix} \right)$
02E□A41		
02E□A61		
03E□A21	$14 \begin{matrix} 0 \\ -0.011 \end{matrix} \left(0.5512 \begin{matrix} 0 \\ -0.00043 \end{matrix} \right)$	$50 \begin{matrix} 0 \\ -0.025 \end{matrix} \left(1.9685 \begin{matrix} 0 \\ -0.00098 \end{matrix} \right)$
03E□A41		
03E□A61		

3.6.2 SGMAJ Servomotors (3000 min⁻¹) Without Gears and With Brakes

(1) 50 W, 100 W

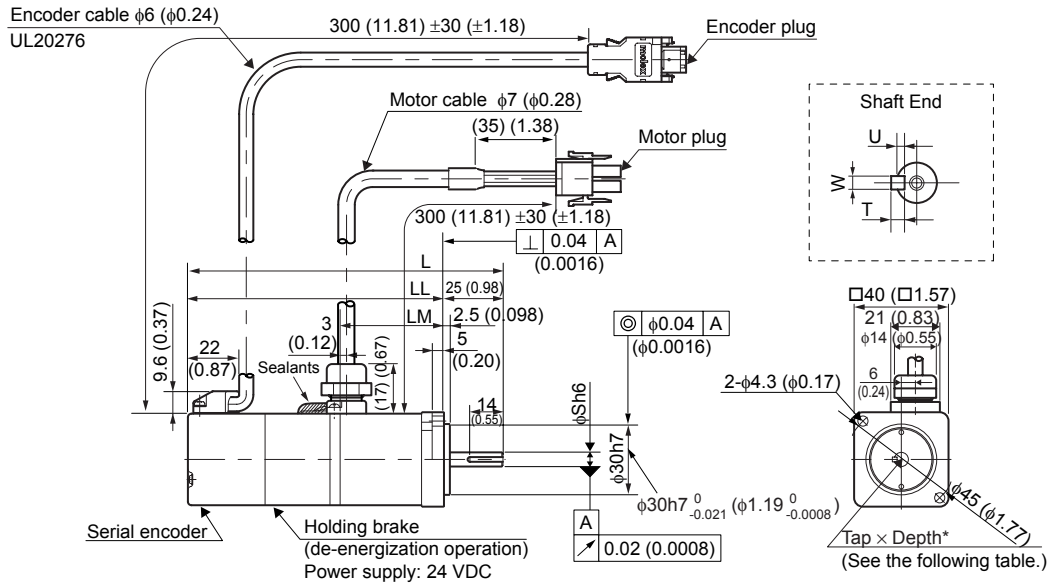

Units: mm (in)

Model SGMAJ-	L	LL	LM	Tap×Depth*	U	W	T	Approx. Mass kg (lb)	Allowable Radial Load N (lbf)	Allowable Thrust Load N (lbf)
A5□□A2□	133.5 (5.26)	108.5 (4.27)	44.0 (1.73)	No tap	No key			0.7 (1.54)	68 (15)	54 (12)
A5□□A4□				1.2 (0.047)	2 (0.079)	2 (0.079)				
A5□□A6□				M2.5×5L						
A8C□A2□	160 (6.30)	135 (5.31)	61.5 (2.42)	No tap	No key			0.8 (1.76)	78 (18)	54 (12)
A8C□A4□				1.8 (0.071)	3 (0.12)	3 (0.12)				
A8C□A6□				M3×6L						
01E□A2□	160.0 (6.30)	135.0 (5.31)	61.5 (2.42)	No tap	No key			0.8 (1.76)	78 (18)	54 (12)
01E□A4□				1.8 (0.071)	3 (0.12)	3 (0.12)				
01E□A6□				M3×6L						



1. The dimensions for L and LL of a servomotor incorporating an encoder with super-capacitor (model: SGMAJ-□□□□) are as shown below.

SGMAJ-A5, A8, and 01: L-dimension +12 mm (0.47 in), LL-dimension +12 mm (0.17 in).

2. The working point of the SGMAJ servomotor radial load is at the position of minus 5 mm from the shaft end.

• Dimensional Tolerances

Units: mm (in)

Model SGMAJ-	Shaft-end Dimensions mm (in)	
	S	
A5□□A2□		
A5□□A4□	$6 \begin{smallmatrix} 0 \\ -0.008 \end{smallmatrix} \begin{smallmatrix} (0.235 \ 0 \\ -0.0003) \end{smallmatrix}$	
A5□□A6□		
A8C□A2□		
A8C□A4□	$8 \begin{smallmatrix} 0 \\ -0.009 \end{smallmatrix} \begin{smallmatrix} (0.315 \ 0 \\ -0.0004) \end{smallmatrix}$	
A8C□A6□		
01□□A2□		
01□□A4□	$8 \begin{smallmatrix} 0 \\ -0.009 \end{smallmatrix} \begin{smallmatrix} (0.315 \ 0 \\ -0.0004) \end{smallmatrix}$	
01□□A6□		

(2) 200 W, 300 W

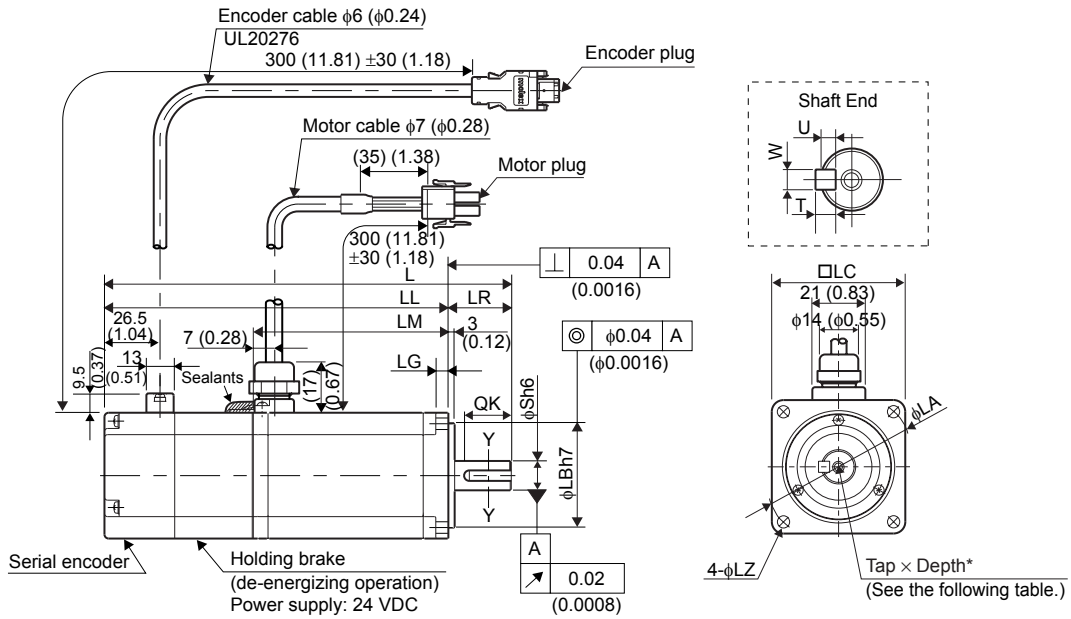

Units: mm (in)

Model SGMAJ-	L	LL	LM	LR	LG	LC	LA	LZ
02E□A2□	166 (6.54)	136 (5.35)	62.5 (2.46)	30 (1.18)	6 (0.24)	60 (2.36)	70 (2.76)	5.5 (0.22)
02E□A4□								
02E□A6□								
03E□A2□	194 (7.64)	164 (6.46)	90.5 (3.56)	30 (1.18)	6 (0.24)	60 (2.36)	70 (2.76)	5.5 (0.22)
03E□A4□								
03E□A6□								

3.6.3 SGMAJ Servomotors (3000 min⁻¹) With Standard Backlash Gears and Without Brakes

Units: mm (in)

Model SGMAJ-	Tap× Depth*	QK	U	W	T	Approx. Mass kg (lb)	Allowable Radial Load N (lbf)	Allowable Thrust Load N (lbf)
02E□A2□	No tap	No key				1.6 (3.53)	245 (55)	74 (17)
02E□A4□		20 (0.79)	3 (0.12)	5 (0.20)	5 (0.20)			
02E□A6□	M5×8L							
03E□A2□	No tap	No key				2.2 (4.85)	245 (55)	74 (17)
03E□A4□		20 (0.79)	3 (0.12)	5 (0.20)	5 (0.20)			
03E□A6□	M5×8L							



- The dimensions for L and LL of a servomotor incorporating an encoder with super-capacitor (model: SGMAJ-□□□4) are as shown below.
SGMAJ-02 and 03: L-dimension +8.2 mm (0.32 in), LL-dimension +8.2 mm (0.32 in)
- The working point of the SGMAJ servomotor radial load is at the position of minus 5 mm from the shaft end.

• Dimensional Tolerances

Units: mm (in)

Model SGMAJ-	Shaft-end Dimensions	Flange Face Dimensions
	S	LB
02E□A2□	14 ⁰ _{-0.011} (0.5512 ⁰ _{-0.00043})	50 ⁰ _{-0.025} (1.9685 ⁰ _{-0.00098})
02E□A4□		
02E□A6□		
03E□A2□	14 ⁰ _{-0.011} (0.5512 ⁰ _{-0.00043})	50 ⁰ _{-0.025} (1.9685 ⁰ _{-0.00098})
03E□A4□		
03E□A6□		

3.6.3 SGMAJ Servomotors (3000 min⁻¹) With Standard Backlash Gears and Without Brakes

(1) 50 W, 80 W, 100 W

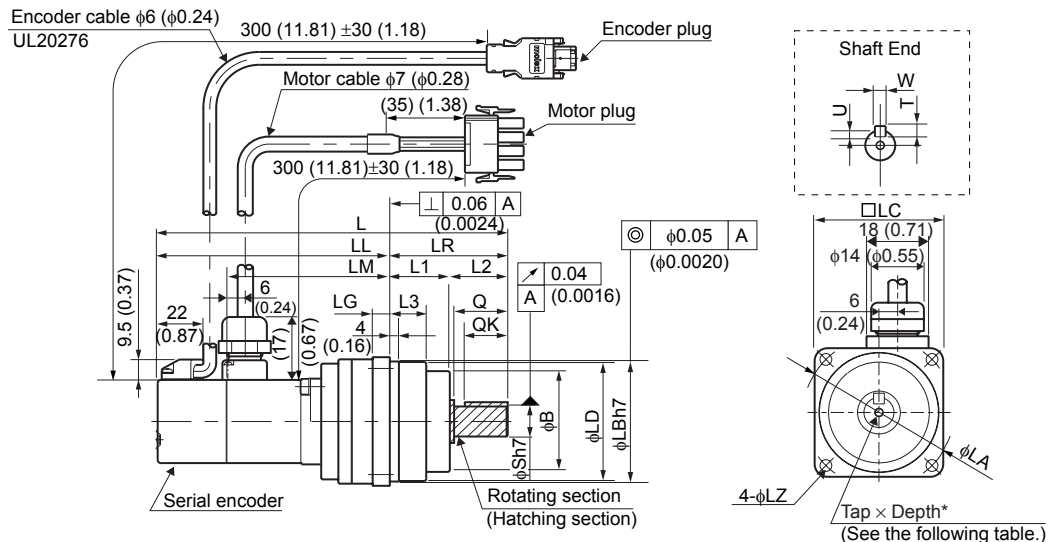

Units: mm (in)

Model SGMAJ-	Gear Ratio	L	LL	LM	LR	LG	B	LD	LB	L1	L2	L3	Q	QK	S
A5□□AJ1□1	1/5	164 (6.46)	109 (4.29)	76.0 (2.99)	55 (2.17)	8 (0.31)	47 (1.85)	55.5 (2.19)	56 (2.20)	28 (1.10)	27 (1.06)	17 (0.67)	25 (0.98)	20 (0.79)	14 (0.55)
A5□□AJ3□1	3/31	174 (6.85)	114 (4.49)	77.0 (3.03)	60 (2.36)	9 (0.35)	57 (2.24)	63 (2.48)	65 (2.56)	30 (1.18)	30 (1.18)	14.5 (0.57)	28 (1.10)	25 (0.98)	16 (0.63)
A5□□AJC□1	1/21	191 (7.52)	131 (5.16)	94.0 (3.70)	60 (2.36)	9 (0.35)	57 (2.24)	63 (2.48)	65 (2.56)	30 (1.18)	30 (1.18)	14.5 (0.57)	28 (1.10)	25 (0.98)	16 (0.63)
A5□□AJ7□1	1/33	191 (7.52)	131 (5.16)	94.0 (3.70)	60 (2.36)	9 (0.35)	57 (2.24)	63 (2.48)	65 (2.56)	30 (1.18)	30 (1.18)	14.5 (0.57)	28 (1.10)	25 (0.98)	16 (0.63)
A8C□AJ1□1	1/5	191.5 (7.54)	131.5 (5.18)	98.5 (3.88)	60 (2.36)	9 (0.35)	57 (2.24)	63 (2.48)	65 (2.56)	30 (1.18)	30 (1.18)	14.5 (0.57)	28 (1.10)	25 (0.98)	16 (0.63)
A8C□AJ3□1	3/31	191.5 (7.54)	131.5 (5.18)	98.5 (3.88)	60 (2.36)	9 (0.35)	57 (2.24)	63 (2.48)	65 (2.56)	30 (1.18)	30 (1.18)	14.5 (0.57)	28 (1.10)	25 (0.98)	16 (0.63)
A8C□AJC□1	1/21	227 (8.94)	153 (6.02)	120 (4.72)	74 (2.91)	10 (0.39)	69 (2.72)	83 (3.27)	85 (3.35)	36 (1.42)	38 (1.50)	19.5 (0.77)	36 (1.42)	32 (1.26)	20 (0.79)
A8C□AJ7□1	1/33	227 (8.94)	153 (6.02)	120 (4.72)	74 (2.91)	10 (0.39)	69 (2.72)	83 (3.27)	85 (3.35)	36 (1.42)	38 (1.50)	19.5 (0.77)	36 (1.42)	32 (1.26)	20 (0.79)
01E□AJ1□1	1/5	191.5 (7.54)	131.5 (5.18)	98.5 (3.88)	60 (2.36)	9 (0.35)	57 (2.24)	63 (2.48)	65 (2.56)	30 (1.18)	30 (1.18)	14.5 (0.57)	28 (1.10)	25 (0.98)	16 (0.63)
01E□AJ3□1	3/31	191.5 (7.54)	131.5 (5.18)	98.5 (3.88)	60 (2.36)	9 (0.35)	57 (2.24)	63 (2.48)	65 (2.56)	30 (1.18)	30 (1.18)	14.5 (0.57)	28 (1.10)	25 (0.98)	16 (0.63)
01E□AJC□1	1/21	227 (8.94)	153 (6.02)	120 (4.72)	74 (2.91)	10 (0.39)	69 (2.72)	83 (3.27)	85 (3.35)	36 (1.42)	38 (1.50)	19.5 (0.77)	36 (1.42)	32 (1.26)	20 (0.79)
01E□AJ7□1	1/33	227 (8.94)	153 (6.02)	120 (4.72)	74 (2.91)	10 (0.39)	69 (2.72)	83 (3.27)	85 (3.35)	36 (1.42)	38 (1.50)	19.5 (0.77)	36 (1.42)	32 (1.26)	20 (0.79)

Units: mm (in)

Model SGMAJ-	Gear Ratio	Tap×Depth*	LC	LA	LZ	U	W	T	Approx. Mass kg (lb)	Allowable Radial Load N (lbf)	Allowable Thrust Load N (lbf)
A5□□AJ1□1	1/5	M4×8L	60 (2.36)	70 (2.76)	5.5 (0.22)	3 (0.12)	5 (0.20)	5 (0.20)	1.0 (2.2)	145 (33)	125 (28)
A5□□AJ3□1	3/31	M4×8L	70 (2.76)	80 (3.15)	6.6 (0.26)	3 (0.12)	5 (0.20)	5 (0.20)	1.2 (2.7)	215 (49)	
A5□□AJC□1	1/21	M4×8L	70 (2.76)	80 (3.15)	6.6 (0.26)	3 (0.12)	5 (0.20)	5 (0.20)	1.3 (2.9)	230 (52)	145 (33)
A5□□AJ7□1	1/33	M4×8L	70 (2.76)	80 (3.15)	6.6 (0.26)	3 (0.12)	5 (0.20)	5 (0.20)	1.3 (2.9)	245 (56)	
A8C□AJ1□1	1/5	M4×8L	70 (2.76)	80 (3.15)	6.6 (0.26)	3 (0.12)	5 (0.20)	5 (0.20)	1.3 (2.9)	175 (40)	145 (33)
A8C□AJ3□1	3/31	M4×8L	70 (2.76)	80 (3.15)	6.6 (0.26)	3 (0.12)	5 (0.20)	5 (0.20)	1.3 (2.9)	215 (49)	
A8C□AJC□1	1/21	M5×10L	90 (3.54)	105 (4.13)	9 (0.35)	3.5 (0.14)	6 (0.24)	6 (0.24)	2.4 (5.3)	455 (103)	235 (53)
A8C□AJ7□1	1/33	M5×10L	90 (3.54)	105 (4.13)	9 (0.35)	3.5 (0.14)	6 (0.24)	6 (0.24)	2.4 (5.3)	480 (109)	
01E□AJ1□1	1/5	M4×8L	70 (2.76)	80 (3.15)	6.6 (0.26)	3 (0.12)	5 (0.20)	5 (0.20)	1.3 (2.9)	175 (40)	145 (33)
01E□AJ3□1	3/31	M4×8L	70 (2.76)	80 (3.15)	6.6 (0.26)	3 (0.12)	5 (0.20)	5 (0.20)	1.3 (2.9)	215 (49)	

3.6.3 SGMAJ Servomotors (3000 min^{-1}) With Standard Backlash Gears and Without Brakes

Units: mm (in) (cont'd)

Model SGMAJ-	Gear Ratio	Tap×Depth*	LC	LA	LZ	U	W	T	Approx. Mass kg (lb)	Allowable Radial Load N (lbf)	Allowable Thrust Load N (lbf)
01E□AJC□1	1/21	M5×10L	90 (3.54)	105 (4.13)	9 (0.35)	3.5 (0.14)	6 (0.24)	6 (0.24)	2.4 (5.3)	455 (103)	235 (53)
01E□AJ7□1	1/33	M5×10L	90 (3.54)	105 (4.13)	9 (0.35)	3.5 (0.14)	6 (0.24)	6 (0.24)	2.4 (5.3)	480 (109)	



- The dimensions for L and LL of a servomotor incorporating an encoder with super-capacitor (model: SGMAJ-□□□4) are as shown below.

SGMAJ-A5, A8, and 01: L-dimension +12 mm (0.47 in), LL-dimension +12 mm (0.47 in)

- The working point of the SGMAJ servomotor radial load is at the position of minus 5 mm from the shaft end.

- Dimensional Tolerances

Units: mm (in)

Model SGMAJ-	Flange Face Dimensions	Shaft-end Dimensions
	LB	S
A5□□AJ1□1	$56 \begin{matrix} 0 \\ -0.030 \end{matrix} \begin{pmatrix} 2.20 & 0 \\ & -0.0012 \end{pmatrix}$	$14 \begin{matrix} 0 \\ -0.018 \end{matrix} \begin{pmatrix} 0.55 & 0 \\ & -0.0007 \end{pmatrix}$
A5□□AJ3□1	$65 \begin{matrix} 0 \\ -0.030 \end{matrix} \begin{pmatrix} 2.56 & 0 \\ & -0.0012 \end{pmatrix}$	$16 \begin{matrix} 0 \\ -0.018 \end{matrix} \begin{pmatrix} 0.63 & 0 \\ & -0.0007 \end{pmatrix}$
A5□□AJC□1	$65 \begin{matrix} 0 \\ -0.030 \end{matrix} \begin{pmatrix} 2.56 & 0 \\ & -0.0012 \end{pmatrix}$	$16 \begin{matrix} 0 \\ -0.018 \end{matrix} \begin{pmatrix} 0.63 & 0 \\ & -0.0007 \end{pmatrix}$
A5□□AJ7□1	$65 \begin{matrix} 0 \\ -0.030 \end{matrix} \begin{pmatrix} 2.56 & 0 \\ & -0.0012 \end{pmatrix}$	$16 \begin{matrix} 0 \\ -0.018 \end{matrix} \begin{pmatrix} 0.63 & 0 \\ & -0.0007 \end{pmatrix}$
A8C□AJ1□1	$65 \begin{matrix} 0 \\ -0.030 \end{matrix} \begin{pmatrix} 2.56 & 0 \\ & -0.0012 \end{pmatrix}$	$16 \begin{matrix} 0 \\ -0.018 \end{matrix} \begin{pmatrix} 0.63 & 0 \\ & -0.0007 \end{pmatrix}$
A8C□AJ3□1	$65 \begin{matrix} 0 \\ -0.030 \end{matrix} \begin{pmatrix} 2.56 & 0 \\ & -0.0012 \end{pmatrix}$	$16 \begin{matrix} 0 \\ -0.018 \end{matrix} \begin{pmatrix} 0.63 & 0 \\ & -0.0007 \end{pmatrix}$
A8C□AJC□1	$85 \begin{matrix} 0 \\ -0.035 \end{matrix} \begin{pmatrix} 3.35 & 0 \\ & -0.0014 \end{pmatrix}$	$20 \begin{matrix} 0 \\ -0.021 \end{matrix} \begin{pmatrix} 0.79 & 0 \\ & -0.0008 \end{pmatrix}$
A8C□AJ7□1	$85 \begin{matrix} 0 \\ -0.035 \end{matrix} \begin{pmatrix} 3.35 & 0 \\ & -0.0014 \end{pmatrix}$	$20 \begin{matrix} 0 \\ -0.021 \end{matrix} \begin{pmatrix} 0.79 & 0 \\ & -0.0008 \end{pmatrix}$
01□□AJ1□1	$65 \begin{matrix} 0 \\ -0.030 \end{matrix} \begin{pmatrix} 2.56 & 0 \\ & -0.0012 \end{pmatrix}$	$16 \begin{matrix} 0 \\ -0.018 \end{matrix} \begin{pmatrix} 0.63 & 0 \\ & -0.0007 \end{pmatrix}$
01□□AJ3□1	$65 \begin{matrix} 0 \\ -0.030 \end{matrix} \begin{pmatrix} 2.56 & 0 \\ & -0.0012 \end{pmatrix}$	$16 \begin{matrix} 0 \\ -0.018 \end{matrix} \begin{pmatrix} 0.63 & 0 \\ & -0.0007 \end{pmatrix}$
01□□AJC□1	$85 \begin{matrix} 0 \\ -0.035 \end{matrix} \begin{pmatrix} 3.35 & 0 \\ & -0.0014 \end{pmatrix}$	$20 \begin{matrix} 0 \\ -0.021 \end{matrix} \begin{pmatrix} 0.79 & 0 \\ & -0.0008 \end{pmatrix}$
01□□AJ7□1	$85 \begin{matrix} 0 \\ -0.035 \end{matrix} \begin{pmatrix} 3.35 & 0 \\ & -0.0014 \end{pmatrix}$	$20 \begin{matrix} 0 \\ -0.021 \end{matrix} \begin{pmatrix} 0.79 & 0 \\ & -0.0008 \end{pmatrix}$

(2) 200 W, 300 W

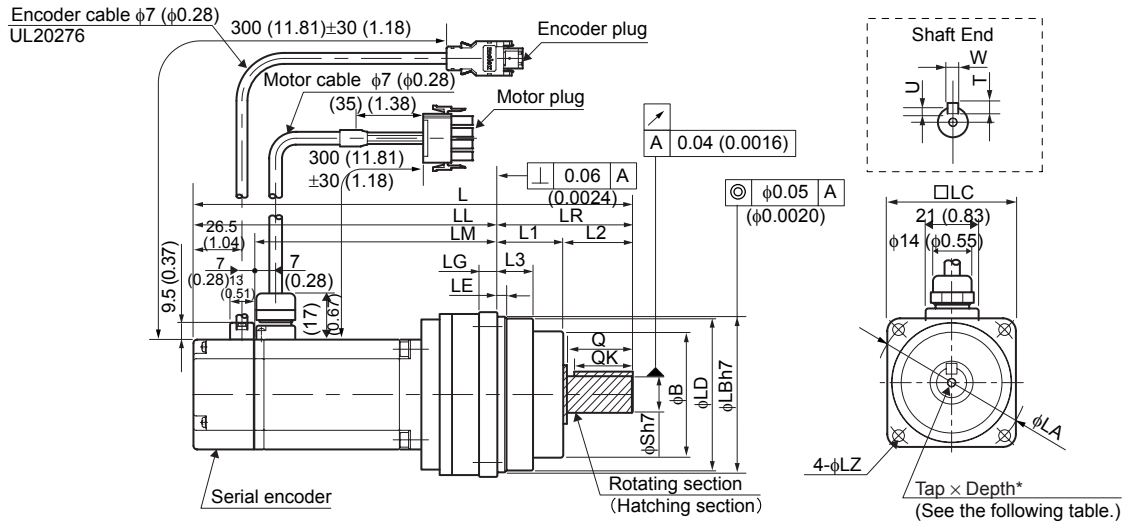

Units: mm (in)

Model SGMAJ-	Gear Ratio	L	LL	LM	LR	LE	LG	B	LD	LB	L1	L2	L3	Q	QK	S
02E□AJ1□1	1/5	212 (8.35)	138 (5.43)	104.5 (4.11)	74 (2.91)	4 (0.16)	10 (0.39)	69 (2.72)	83 (3.27)	85 (3.35)	36 (1.42)	38 (1.50)	19.5 (0.77)	36 (1.42)	32 (1.26)	20 (0.79)
02E□AJ3□1	3/31	212 (8.35)	138 (5.43)	104.5 (4.11)	74 (2.91)	4 (0.16)	10 (0.39)	69 (2.72)	83 (3.27)	85 (3.35)	36 (1.42)	38 (1.50)	19.5 (0.77)	36 (1.42)	32 (1.26)	20 (0.79)
02E□AJC□1	1/21	249.5 (9.82)	165.5 (6.52)	132 (5.20)	84 (3.31)	4 (0.16)	12 (0.47)	82 (3.23)	98 (3.86)	100 (3.94)	40 (1.57)	44 (1.73)	23 (0.91)	42 (1.65)	36 (1.42)	25 (0.98)
02E□AJ7□1	1/33	249.5 (9.82)	165.5 (6.52)	132 (5.20)	84 (3.31)	4 (0.16)	12 (0.47)	82 (3.23)	98 (3.86)	100 (3.94)	40 (1.57)	44 (1.73)	23 (0.91)	42 (1.65)	36 (1.42)	25 (0.98)
03E□AJ1□1	1/5	240 (9.45)	166 (6.54)	133 (5.24)	74 (2.91)	4 (0.16)	10 (0.39)	69 (2.72)	83 (3.27)	85 (3.35)	36 (1.42)	38 (1.50)	19.5 (0.77)	36 (1.42)	32 (1.26)	20 (0.79)
03E□AJ3□1	3/31	256.5 (10.10)	172.5 (6.79)	139 (5.47)	84 (3.31)	4 (0.16)	12 (0.47)	82 (3.23)	98 (3.86)	100 (3.94)	40 (1.57)	44 (1.73)	23 (0.91)	42 (1.65)	36 (1.42)	25 (0.98)
03E□AJC□1	1/21	305.5 (12.03)	200.5 (7.89)	167 (6.57)	105 (4.13)	5 (0.20)	13 (0.51)	93 (3.66)	112 (4.41)	115 (4.53)	45 (1.77)	60 (2.36)	26.5 (1.04)	58 (2.28)	50 (1.97)	32 (1.26)
03E□AJ7□1	1/33	305.5 (12.03)	200.5 (7.89)	167 (6.57)	105 (4.13)	5 (0.20)	13 (0.51)	93 (3.66)	112 (4.41)	115 (4.53)	45 (1.77)	60 (2.36)	26.5 (1.04)	58 (2.28)	50 (1.97)	32 (1.26)

Units: mm (in)

Model SGMAJ-	Gear Ratio	LC	LA	LZ	Tap \times Depth *	U	W	T	Approx. Mass kg (lb)	Allowable Radial Load N (lbf)	Allowable Thrust Load N (lbf)
02E□AJ1□1	1/5	90 (3.54)	105 (4.13)	9 (0.35)	M5 \times 10L	3.5 (0.14)	6 (0.24)	6 (0.24)	2.8 (6.2)	275 (62)	235 (53)
02E□AJ3□1	3/31	90 (3.54)	105 (4.13)	9 (0.35)	M5 \times 10L	3.5 (0.14)	6 (0.24)	6 (0.24)	2.8 (6.2)	360 (82)	
02E□AJC□1	1/21	105 (4.13)	120 (4.72)	9 (0.35)	M6 \times 12L	4 (0.16)	8 (0.31)	7 (0.28)	4.2 (9.3)	585 (133)	290 (66)
02E□AJ7□1	1/33	105 (4.13)	120 (4.72)	9 (0.35)	M6 \times 12L	4 (0.16)	8 (0.31)	7 (0.28)	4.2 (9.3)	635 (144)	
03E□AJ1□1	1/5	90 (3.54)	105 (4.13)	9 (0.35)	M5 \times 10L	3.5 (0.14)	6 (0.24)	6 (0.24)	3.4 (7.5)	275 (62)	235 (53)
03E□AJ3□1	3/31	105 (4.13)	120 (4.72)	9 (0.35)	M6 \times 12L	4 (0.16)	8 (0.31)	7 (0.28)	4.3 (9.5)	460 (104)	290 (66)

3.6.3 SGMAJ Servomotors (3000 min^{-1}) With Standard Backlash Gears and Without Brakes

Units: mm (in) (cont'd)

Model SGMAJ-	Gear Ratio	LC	LA	LZ	Tap×Depth *	U	W	T	Approx. Mass kg (lb)	Allowable Radial Load N (lbf)	Allowable Thrust Load N (lbf)
03E□AJC□1	1/21	120 (4.72)	135 (5.31)	11 (0.43)	M8×16L	5 (0.20)	10 (0.39)	8 (0.31)	6.4 (14.1)	655 (149)	310 (70)
03E□AJ7□1	1/33	120 (4.72)	135 (5.31)	11 (0.43)	M8×16L	5 (0.20)	10 (0.39)	8 (0.31)	6.4 (14.1)	755 (171)	



- The dimensions for L and LL of a servomotor incorporating an encoder with super-capacitor (model: SGMAJ-□□□4) are as shown below.

SGMAJ-02 and 03: L-dimension + 8.2 mm (0.32 in), LL-dimension +8.2 mm (0.32 in)

- The working point of the SGMAJ servomotor radial load is at the position of minus 5 mm from the shaft end.

- Dimensional Tolerances

Units: mm (in)

Model SGMAJ-	Flange Face Dimensions	Shaft-end Dimensions
	LB	S
02E□AJ1□1	$85 \begin{smallmatrix} 0 \\ -0.035 \end{smallmatrix} \begin{smallmatrix} (3.35 \\ -0.0014) \end{smallmatrix}$	$20 \begin{smallmatrix} 0 \\ -0.021 \end{smallmatrix} \begin{smallmatrix} (0.79 \\ -0.0008) \end{smallmatrix}$
02E□AJ3□1	$85 \begin{smallmatrix} 0 \\ -0.035 \end{smallmatrix} \begin{smallmatrix} (3.35 \\ -0.0014) \end{smallmatrix}$	$20 \begin{smallmatrix} 0 \\ -0.021 \end{smallmatrix} \begin{smallmatrix} (0.79 \\ -0.0008) \end{smallmatrix}$
02E□AJC□1	$100 \begin{smallmatrix} 0 \\ -0.035 \end{smallmatrix} \begin{smallmatrix} (3.94 \\ -0.0014) \end{smallmatrix}$	$25 \begin{smallmatrix} 0 \\ -0.021 \end{smallmatrix} \begin{smallmatrix} (0.98 \\ -0.0008) \end{smallmatrix}$
02E□AJ7□1	$100 \begin{smallmatrix} 0 \\ -0.035 \end{smallmatrix} \begin{smallmatrix} (3.94 \\ -0.0014) \end{smallmatrix}$	$25 \begin{smallmatrix} 0 \\ -0.021 \end{smallmatrix} \begin{smallmatrix} (0.98 \\ -0.0008) \end{smallmatrix}$
03E□AJ1□1	$85 \begin{smallmatrix} 0 \\ -0.035 \end{smallmatrix} \begin{smallmatrix} (3.35 \\ -0.0014) \end{smallmatrix}$	$20 \begin{smallmatrix} 0 \\ -0.021 \end{smallmatrix} \begin{smallmatrix} (0.79 \\ -0.0008) \end{smallmatrix}$
03E□AJ3□1	$100 \begin{smallmatrix} 0 \\ -0.035 \end{smallmatrix} \begin{smallmatrix} (3.94 \\ -0.0014) \end{smallmatrix}$	$25 \begin{smallmatrix} 0 \\ -0.021 \end{smallmatrix} \begin{smallmatrix} (0.98 \\ -0.0008) \end{smallmatrix}$
03E□AJC□1	$115 \begin{smallmatrix} 0 \\ -0.035 \end{smallmatrix} \begin{smallmatrix} (4.53 \\ -0.0014) \end{smallmatrix}$	$32 \begin{smallmatrix} 0 \\ -0.025 \end{smallmatrix} \begin{smallmatrix} (1.26 \\ -0.0010) \end{smallmatrix}$
03E□AJ7□1	$115 \begin{smallmatrix} 0 \\ -0.035 \end{smallmatrix} \begin{smallmatrix} (4.53 \\ -0.0014) \end{smallmatrix}$	$32 \begin{smallmatrix} 0 \\ -0.025 \end{smallmatrix} \begin{smallmatrix} (1.26 \\ -0.0010) \end{smallmatrix}$

3.6.4 SGMAJ Servomotors (3000 min⁻¹) With Standard Backlash Gears and Brakes (1) 50 W, 80 W, 100 W

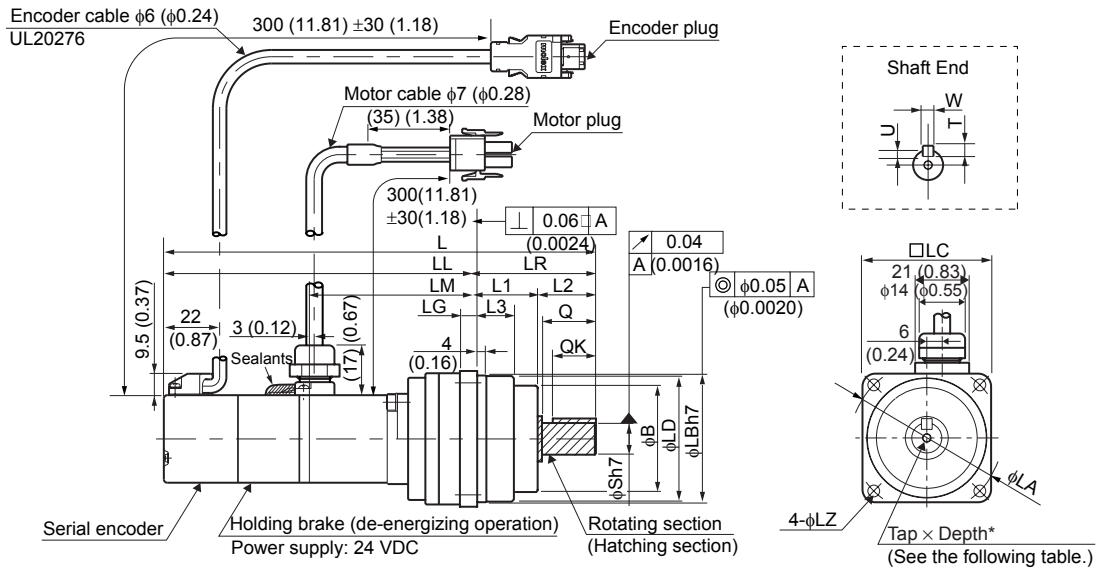

3

Units: mm (in)

Model SGMAJ-	Gear Ratio	L	LL	LM	LR	LG	B	LD	LB	L1	L2	L3	Q	QK	S
A5□□AJ1□□	1/5	196 (7.72)	141 (5.55)	76.0 (2.99)	55 (2.17)	8 (0.31)	47 (1.85)	55.5 (2.19)	56 (2.20)	28 (1.10)	27 (1.06)	17 (0.67)	25 (0.98)	20 (0.79)	14 (0.55)
A5□□AJ3□□	3/31	206 (8.11)	146 (5.75)	77.0 (3.03)	60 (2.36)	9 (0.35)	57 (2.24)	63 (2.48)	65 (2.56)	30 (1.18)	30 (1.18)	14.5 (0.57)	28 (1.10)	25 (0.98)	16 (0.63)
A5□□AJC□□	1/21	223 (8.78)	163 (6.42)	94.0 (3.70)	60 (2.36)	9 (0.35)	57 (2.24)	63 (2.48)	65 (2.56)	30 (1.18)	30 (1.18)	14.5 (0.57)	28 (1.10)	25 (0.98)	16 (0.63)
A5□□AJ7□□	1/33	223 (8.78)	163 (6.42)	94.0 (3.70)	60 (2.36)	9 (0.35)	57 (2.24)	63 (2.48)	65 (2.56)	30 (1.18)	30 (1.18)	14.5 (0.57)	28 (1.10)	25 (0.98)	16 (0.63)
A8C□AJ1□1	1/5	232 (9.13)	172 (6.77)	98.5 (3.88)	60 (2.36)	9 (0.35)	25 (0.98)	63 (2.48)	65 (2.56)	30 (1.18)	30 (1.18)	14.5 (0.57)	28 (1.10)	25 (0.98)	16 (0.63)
A8C□AJ3□1	3/31	232 (9.13)	172 (6.77)	98.5 (3.88)	60 (2.36)	9 (0.35)	25 (0.98)	63 (2.48)	65 (2.56)	30 (1.18)	30 (1.18)	14.5 (0.57)	28 (1.10)	25 (0.98)	16 (0.63)
A8C□AJC□1	1/21	268 (10.6)	194 (7.64)	120 (4.72)	74 (2.91)	10 (0.39)	69 (2.72)	83 (3.27)	85 (3.35)	36 (1.42)	38 (1.50)	19.5 (0.77)	36 (1.42)	32 (1.26)	20 (0.79)
A8C□AJ7□1	1/33	268 (10.6)	194 (7.64)	120 (4.72)	74 (2.91)	10 (0.39)	69 (2.72)	83 (3.27)	85 (3.35)	36 (1.42)	38 (1.50)	19.5 (0.77)	36 (1.42)	32 (1.26)	20 (0.79)
01E□AJ1□□	1/5	232 (9.13)	172 (6.77)	98.5 (3.88)	60 (2.36)	9 (0.35)	25 (0.98)	63 (2.48)	65 (2.56)	30 (1.18)	30 (1.18)	14.5 (0.57)	28 (1.10)	25 (0.98)	16 (0.63)
01E□AJ3□□	3/31	232 (9.13)	172 (6.77)	98.5 (3.88)	60 (2.36)	9 (0.35)	25 (0.98)	63 (2.48)	65 (2.56)	30 (1.18)	30 (1.18)	14.5 (0.57)	28 (1.10)	25 (0.98)	16 (0.63)
01E□AJC□□	1/21	268 (10.6)	194 (7.64)	120 (4.72)	74 (2.91)	10 (0.39)	69 (2.72)	83 (3.27)	85 (3.35)	36 (1.42)	38 (1.50)	19.5 (0.77)	36 (1.42)	32 (1.26)	20 (0.79)
01E□AJ7□□	1/33	268 (10.6)	194 (7.64)	120 (4.72)	74 (2.91)	10 (0.39)	69 (2.72)	83 (3.27)	85 (3.35)	36 (1.42)	38 (1.50)	19.5 (0.77)	36 (1.42)	32 (1.26)	20 (0.79)

Units: mm (in)

Model SGMAJ-	Gear Ratio	LC	LA	LZ	Tap×Depth	U	W	T	Approx. Mass kg (lb)	Allowable Radial Load N (lbf)	Allowable Thrust Load N (lbf)
A5□□AJ1□□	1/5	60 (2.36)	70 (2.76)	5.5 (0.22)	M4×8L	3 (0.12)	5 (0.20)	5 (0.20)	1.3 (2.9)	145 (33)	125 (28)
A5□□AJ3□□	3/31	70 (2.76)	80 (3.15)	6.6 (0.26)	M4×8L	3 (0.12)	5 (0.20)	5 (0.20)	1.5 (3.3)	215 (49)	
A5□□AJC□□	1/21	70 (2.76)	80 (3.15)	6.6 (0.26)	M4×8L	3 (0.12)	5 (0.20)	5 (0.20)	1.6 (3.5)	230 (52)	145 (33)
A5□□AJ7□□	1/33	70 (2.76)	80 (3.15)	6.6 (0.26)	M4×8L	3 (0.12)	5 (0.20)	5 (0.20)	1.6 (3.5)	245 (56)	
A8C□AJ1□1	1/5	70 (2.76)	80 (3.15)	6.6 (0.26)	M4×8L	3 (0.12)	5 (0.20)	5 (0.20)	1.6 (3.5)	175 (40)	145 (33)
A8C□AJ3□1	3/31	70 (2.76)	80 (3.15)	6.6 (0.26)	M4×8L	3 (0.12)	5 (0.20)	5 (0.20)	1.6 (3.5)	215 (49)	
A8C□AJC□1	1/21	90 (3.54)	105 (4.13)	9 (0.35)	M5×10L	3.5 (0.14)	6 (0.24)	6 (0.24)	2.7 (6.0)	455 (103)	235 (53)
A8C□AJ7□1	1/33	90 (3.54)	105 (4.13)	9 (0.35)	M5×10L	3.5 (0.14)	6 (0.24)	6 (0.24)	2.7 (6.0)	480 (109)	
01E□AJ1□□	1/5	70 (2.76)	80 (3.15)	6.6 (0.26)	M4×8L	3 (0.12)	5 (0.20)	5 (0.20)	1.6 (3.5)	175 (40)	145 (33)
01E□AJ3□□	3/31	70 (2.76)	80 (3.15)	6.6 (0.26)	M4×8L	3 (0.12)	5 (0.20)	5 (0.20)	1.6 (3.5)	215 (49)	
01E□AJC□□	1/21	90 (3.54)	105 (4.13)	9 (0.35)	M5×10L	3.5 (0.14)	6 (0.24)	6 (0.24)	2.7 (6.0)	455 (103)	235 (53)
01E□AJ7□□	1/33	90 (3.54)	105 (4.13)	9 (0.35)	M5×10L	3.5 (0.14)	6 (0.24)	6 (0.24)	2.7 (6.0)	480 (109)	



- The dimensions for L and LL of a servomotor incorporating an encoder with super-capacitor (model: SGMAJ-□□□□4) are as shown below.

SGMAJ-A5, A8, and 01: L-dimension +12 mm (0.47 in), LL-dimension +12 mm (0.47 in)

- The working point of the SGMAJ servomotor radial load is at the position of minus 5 mm from the shaft end.

• Dimensional Tolerances

Units: mm (in)

Model SGMAJ-	Flange Face Dimensions	Shaft-end Dimensions
	LB	S
A5□□AJ1□□	$56 \begin{matrix} 0 \\ -0.030 \end{matrix} \begin{matrix} (2.20 \\ -0.0012) \end{matrix}$	$14 \begin{matrix} 0 \\ -0.018 \end{matrix} \begin{matrix} (0.55 \\ -0.0007) \end{matrix}$
A5□□AJ3□□	$65 \begin{matrix} 0 \\ -0.030 \end{matrix} \begin{matrix} (2.56 \\ -0.0012) \end{matrix}$	$16 \begin{matrix} 0 \\ -0.018 \end{matrix} \begin{matrix} (0.63 \\ -0.0007) \end{matrix}$
A5□□AJC□□	$65 \begin{matrix} 0 \\ -0.030 \end{matrix} \begin{matrix} (2.56 \\ -0.0012) \end{matrix}$	$16 \begin{matrix} 0 \\ -0.018 \end{matrix} \begin{matrix} (0.63 \\ -0.0007) \end{matrix}$
A5□□AJ7□□	$65 \begin{matrix} 0 \\ -0.030 \end{matrix} \begin{matrix} (2.56 \\ -0.0012) \end{matrix}$	$16 \begin{matrix} 0 \\ -0.018 \end{matrix} \begin{matrix} (0.63 \\ -0.0007) \end{matrix}$
A8C□AJ1□1	$65 \begin{matrix} 0 \\ -0.030 \end{matrix} \begin{matrix} (2.56 \\ -0.0012) \end{matrix}$	$16 \begin{matrix} 0 \\ -0.018 \end{matrix} \begin{matrix} (0.63 \\ -0.0007) \end{matrix}$
A8C□AJ3□1	$65 \begin{matrix} 0 \\ -0.030 \end{matrix} \begin{matrix} (2.56 \\ -0.0012) \end{matrix}$	$16 \begin{matrix} 0 \\ -0.018 \end{matrix} \begin{matrix} (0.63 \\ -0.0007) \end{matrix}$
A8C□AJC□1	$85 \begin{matrix} 0 \\ -0.035 \end{matrix} \begin{matrix} (3.35 \\ -0.0014) \end{matrix}$	$20 \begin{matrix} 0 \\ -0.021 \end{matrix} \begin{matrix} (0.79 \\ -0.0008) \end{matrix}$

Units: mm (in) (cont'd)

Model SGMAJ-	Flange Face Dimensions		Shaft-end Dimensions	
	LB		S	
A8C□AJ7□1	85 ⁰ _{-0.035}	(3.35 ⁰ _{-0.0014})	20 ⁰ _{-0.021}	(0.79 ⁰ _{-0.0008})
01E□AJ1□□	65 ⁰ _{-0.030}	(2.56 ⁰ _{-0.0012})	16 ⁰ _{-0.018}	(0.63 ⁰ _{-0.0007})
01E□AJ3□□	65 ⁰ _{-0.030}	(2.56 ⁰ _{-0.0012})	16 ⁰ _{-0.018}	(0.63 ⁰ _{-0.0007})
01E□AJC□□	85 ⁰ _{-0.035}	(3.35 ⁰ _{-0.0014})	20 ⁰ _{-0.021}	(0.79 ⁰ _{-0.0008})
01E□AJ7□□	85 ⁰ _{-0.035}	(3.35 ⁰ _{-0.0014})	20 ⁰ _{-0.021}	(0.79 ⁰ _{-0.0008})

(2) 200 W, 300 W

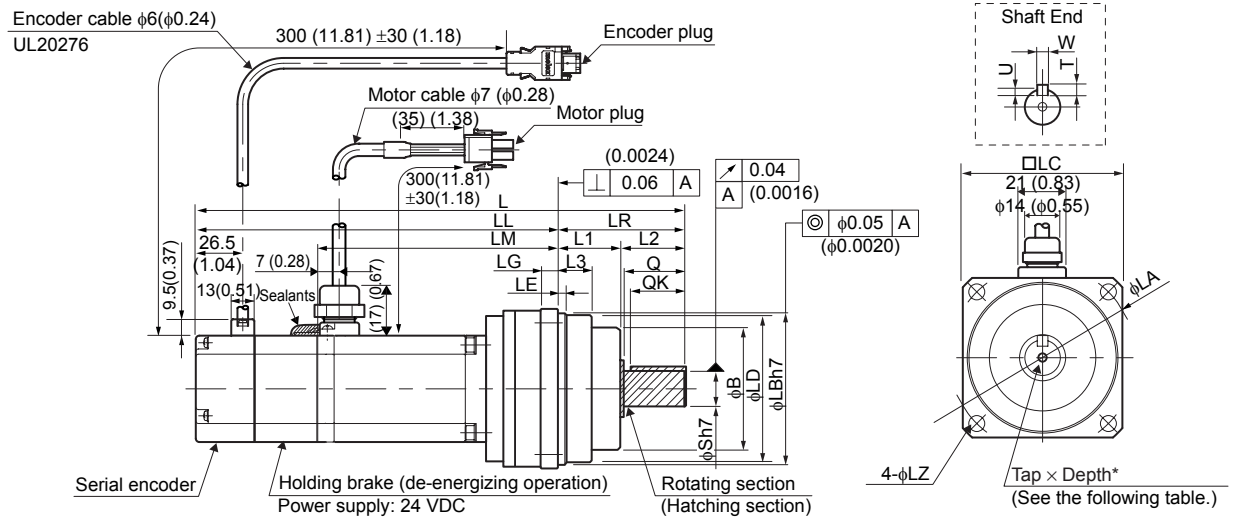

Units: mm (in)

Model SGMAJ-	Gear Ratio	L	LL	LM	LR	LE	LG	B	LD	LB	L1	L2	L3	Q	QK	S
02E□AJ1□□	1/5	251.5 (9.90)	177.5 (6.99)	104.5 (4.11)	74 (2.91)	4 (0.16)	10 (0.39)	69 (2.72)	83 (3.27)	85 (3.35)	36 (1.42)	38 (1.50)	19.5 (0.77)	36 (1.42)	32 (1.26)	20 (0.79)
02E□AJ3□□	3/31	251.5 (9.90)	177.5 (6.99)	104.5 (4.11)	74 (2.91)	4 (0.16)	10 (0.39)	69 (2.72)	83 (3.27)	85 (3.35)	36 (1.42)	36 (1.42)	19.5 (0.77)	36 (1.42)	32 (1.26)	20 (0.79)
02E□AJC□□	1/21	289 (11.38)	205 (8.07)	132 (5.20)	84 (3.31)	4 (0.16)	12 (0.47)	82 (3.23)	98 (3.86)	100 (3.94)	40 (1.57)	44 (1.73)	19.5 (0.77)	42 (1.65)	36 (1.42)	25 (0.98)
02E□AJ7□□	1/33	289 (11.38)	205 (8.07)	132 (5.20)	84 (3.31)	4 (0.16)	12 (0.47)	82 (3.23)	98 (3.86)	100 (3.94)	40 (1.57)	44 (1.73)	19.5 (0.77)	42 (1.65)	36 (1.42)	25 (0.98)
03E□AJ1□□	1/5	297.5 (11.71)	223.5 (8.80)	150.5 (5.93)	74 (2.91)	4 (0.16)	10 (0.39)	69 (2.72)	83 (3.27)	85 (3.35)	36 (1.42)	38 (1.50)	19.5 (0.77)	36 (1.42)	32 (1.26)	20 (0.79)
03E□AJ3□□	3/31	296 (11.65)	212 (8.35)	139 (5.47)	84 (3.31)	4 (0.16)	12 (0.47)	82 (3.23)	98 (3.86)	100 (3.94)	40 (1.57)	44 (1.73)	23 (0.91)	42 (1.65)	36 (1.42)	25 (0.98)
03E□AJC□□	1/21	345 (13.58)	240 (9.45)	167 (6.57)	105 (4.13)	5 (0.20)	13 (0.51)	93 (3.66)	112 (4.41)	115 (4.53)	45 (1.77)	60 (2.36)	26.5 (1.04)	58 (2.28)	50 (1.97)	32 (1.26)
03E□AJ7□□	1/33	345 (13.58)	240 (9.45)	167 (6.57)	105 (4.13)	5 (0.20)	13 (0.51)	93 (3.66)	112 (4.41)	115 (4.53)	45 (1.77)	80 (3.15)	26.5 (1.04)	58 (2.28)	50 (1.97)	32 (1.26)

Units: mm (in)

Model SGMAJ-	Gear Ratio	LC	LA	LZ	Tap×Depth *	U	W	T	Approx. Mass kg (lb)	Allowable Radial Load N (lbf)	Allowable Thrust Load N (lbf)
02E□AJ1□□	1/5	90 (3.54)	105 (4.13)	9 (0.35)	M5×10L	3.5 (0.14)	6 (0.24)	6 (0.24)	3.3 (7.3)	275 (62)	235 (53)
02E□AJ3□□	3/31	90 (3.54)	105 (4.13)	9 (0.35)	M5×10L	3.5 (0.14)	6 (0.24)	6 (0.24)	3.3 (7.3)	360 (82)	
02E□AJC□□	1/21	105 (4.13)	120 (4.72)	9 (0.35)	M6×12L	4 (0.16)	8 (0.31)	7 (0.28)	4.7 (10.4)	585 (132)	290 (66)
02E□AJ7□□	1/33	105 (4.13)	120 (4.72)	9 (0.35)	M6×12L	4 (0.16)	8 (0.31)	7 (0.28)	4.7 (10.4)	635 (133)	
03E□AJ1□□	1/5	90 (3.54)	105 (4.13)	9 (0.35)	M5×10L	3.5 (0.14)	6 (0.24)	6 (0.24)	3.9 (8.6)	275 (62)	235 (53)
03E□AJ3□□	3/31	105 (4.13)	120 (4.72)	9 (0.35)	M6×12L	4 (0.16)	8 (0.31)	7 (0.28)	4.8 (10.6)	460 (104)	290 (66)
03E□AJC□□	1/21	120 (4.72)	135 (5.31)	11 (0.43)	M8×16L	5 (0.20)	10 (0.39)	8 (0.31)	6.9 (15.2)	655 (149)	310 (70)
03E□AJ7□□	1/33	120 (4.72)	135 (5.31)	11 (0.43)	M8×16L	5 (0.20)	10 (0.39)	8 (0.31)	6.9 (15.2)	755 (171)	



- The dimensions for L and LL of a servomotor incorporating an encoder with super-capacitor (model: SGMAJ-□□□4) are as shown below.

SGMAJ-02 and 03: L-dimension + 8.2 mm (0.32 in), LL-dimension + 8.2 mm (0.32 in)

- The working point of the SGMAJ servomotor radial load is at the position of minus 5 mm from the shaft end.

• Dimensional Tolerances

Units: mm (in)

Model SGMAJ-	Flange Face Dimensions	Shaft-end Dimensions
	LB	S
02E□AJ1□□	$85 \begin{matrix} 0 \\ -0.035 \end{matrix} \begin{matrix} (3.35 \\ -0.0014) \end{matrix}$	$20 \begin{matrix} 0 \\ -0.021 \end{matrix} \begin{matrix} (0.79 \\ -0.0008) \end{matrix}$
02E□AJ3□□	$85 \begin{matrix} 0 \\ -0.035 \end{matrix} \begin{matrix} (3.35 \\ -0.0014) \end{matrix}$	$20 \begin{matrix} 0 \\ -0.021 \end{matrix} \begin{matrix} (0.79 \\ -0.0008) \end{matrix}$
02E□AJC□□	$100 \begin{matrix} 0 \\ -0.035 \end{matrix} \begin{matrix} (3.94 \\ -0.0014) \end{matrix}$	$25 \begin{matrix} 0 \\ -0.021 \end{matrix} \begin{matrix} (0.98 \\ -0.0008) \end{matrix}$
02E□AJ7□□	$100 \begin{matrix} 0 \\ -0.035 \end{matrix} \begin{matrix} (3.94 \\ -0.0014) \end{matrix}$	$25 \begin{matrix} 0 \\ -0.021 \end{matrix} \begin{matrix} (0.98 \\ -0.0008) \end{matrix}$
03E□AJ1□□	$85 \begin{matrix} 0 \\ -0.035 \end{matrix} \begin{matrix} (3.35 \\ -0.0014) \end{matrix}$	$20 \begin{matrix} 0 \\ -0.021 \end{matrix} \begin{matrix} (0.79 \\ -0.0008) \end{matrix}$
03E□AJ3□□	$100 \begin{matrix} 0 \\ -0.035 \end{matrix} \begin{matrix} (3.94 \\ -0.0014) \end{matrix}$	$25 \begin{matrix} 0 \\ -0.021 \end{matrix} \begin{matrix} (0.98 \\ -0.0008) \end{matrix}$
03E□AJC□□	$115 \begin{matrix} 0 \\ -0.035 \end{matrix} \begin{matrix} (4.53 \\ -0.0014) \end{matrix}$	$32 \begin{matrix} 0 \\ -0.025 \end{matrix} \begin{matrix} (1.26 \\ -0.0010) \end{matrix}$
03E□AJ7□□	$115 \begin{matrix} 0 \\ -0.035 \end{matrix} \begin{matrix} (4.53 \\ -0.0014) \end{matrix}$	$32 \begin{matrix} 0 \\ -0.025 \end{matrix} \begin{matrix} (1.26 \\ -0.0010) \end{matrix}$

3.6.5 SGMAJ Servomotors (3000 min⁻¹) With Low-backlash Gears and Without Brakes

(1) 50 W, 80 W, 100 W

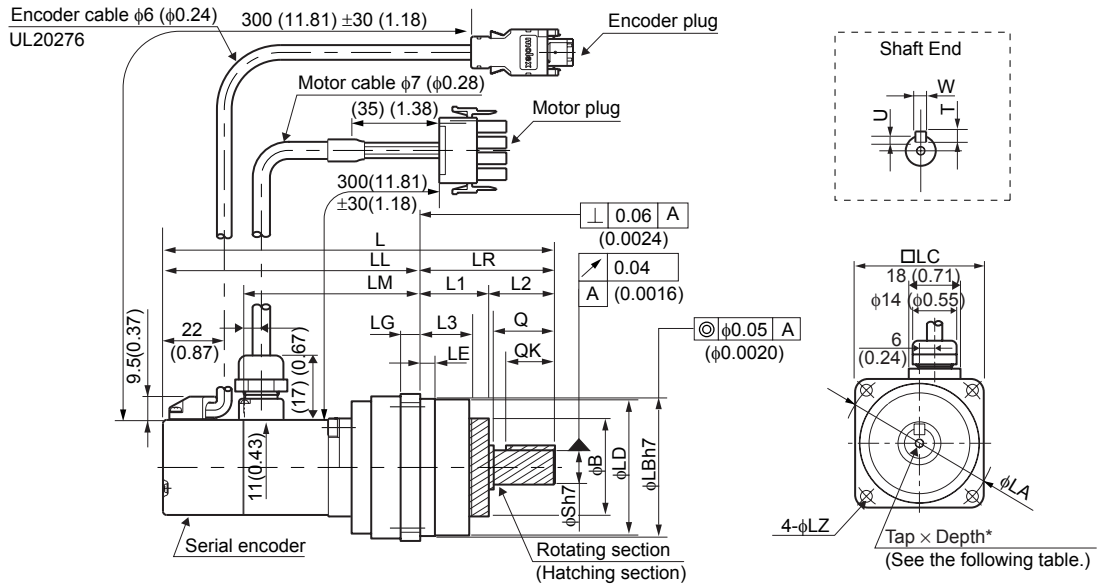

Units: mm (in)

Model SGMAJ-	Gear Ratio	L	LL	LM	LR	LE	LG	B	LD	LB	L1	L2	L3	Q	QK	S
A5□□AH1□1	1/5	160 (6.30)	105 (4.13)	72.0 (2.83)	55 (2.17)	6 (0.24)	8 (0.31)	40 (1.57)	55.5 (2.19)	56 (2.20)	28 (1.10)	27 (1.06)	20 (0.79)	25 (0.98)	20 (0.79)	14 (0.55)
A5□□AH2□1	1/9	166 (6.54)	106 (4.17)	73.0 (2.87)	60 (2.36)	8 (0.31)	9 (0.35)	50 (1.97)	64.5 (2.54)	65 (2.56)	30 (1.18)	30 (1.18)	22 (0.87)	28 (1.10)	25 (0.98)	16 (0.63)
A5□□AHC□1	1/21	183 (7.20)	123 (4.84)	90.0 (3.54)	60 (2.36)	8 (0.31)	9 (0.35)	40 (1.57)	64.5 (2.54)	65 (2.56)	30 (1.18)	30 (1.18)	22 (0.87)	28 (1.10)	25 (0.98)	16 (0.63)
A5□□AH7□1	1/33	183 (7.20)	123 (4.84)	90.0 (3.54)	60 (2.36)	8 (0.31)	9 (0.35)	40 (1.57)	64.5 (2.54)	65 (2.56)	30 (1.18)	30 (1.18)	22 (0.87)	28 (1.10)	25 (0.98)	16 (0.63)
A8C□AH1□1	1/5	183.5 (7.22)	123.5 (4.86)	90.5 (3.56)	60 (2.36)	8 (0.31)	9 (0.35)	40 (1.57)	64.5 (2.54)	65 (2.56)	30 (1.18)	30 (1.18)	21 (0.83)	28 (1.10)	25 (0.98)	16 (0.63)
A8C□AHB□1	1/11	200.5 (7.89)	140.5 (5.53)	107.5 (4.23)	60 (2.36)	8 (0.31)	9 (0.35)	40 (1.57)	64.5 (2.54)	65 (2.56)	30 (1.18)	30 (1.18)	21 (0.83)	28 (1.10)	25 (0.98)	16 (0.63)
A8C□AHC□1	1/21	223.5 (8.80)	149.5 (5.89)	116.5 (4.59)	74 (2.91)	7.5 (0.30)	10 (0.39)	59 (2.32)	84 (3.31)	85 (3.35)	36 (1.42)	38 (1.50)	26 (1.02)	36 (1.42)	32 (1.26)	20 (0.79)
A8C□AH7□1	1/33	223.5 (8.80)	149.5 (5.89)	116.5 (4.59)	74 (2.91)	7.5 (0.30)	10 (0.39)	59 (2.32)	84 (3.31)	85 (3.35)	36 (1.42)	38 (1.50)	26 (1.02)	36 (1.42)	32 (1.26)	20 (0.79)
01E□AH1□1	1/5	183.5 (7.22)	123.5 (4.86)	90.5 (3.56)	60 (2.36)	8 (0.31)	9 (0.35)	40 (1.57)	64.5 (2.54)	65 (2.56)	30 (1.18)	30 (1.18)	21 (0.83)	28 (1.10)	25 (0.98)	16 (0.63)
01E□AHB□1	1/11	200.5 (7.89)	140.5 (5.53)	107.5 (4.23)	60 (2.36)	8 (0.31)	9 (0.35)	40 (1.57)	64.5 (2.54)	65 (2.56)	30 (1.18)	30 (1.18)	21 (0.83)	28 (1.10)	25 (0.98)	16 (0.63)
01E□AHC□1	1/21	223.5 (8.80)	149.5 (5.89)	116.5 (4.59)	74 (2.91)	7.5 (0.30)	10 (0.39)	59 (2.32)	84 (3.31)	85 (3.35)	36 (1.42)	38 (1.50)	26 (1.02)	36 (1.42)	32 (1.26)	20 (0.79)
01E□AH7□1	1/33	223.5 (8.80)	149.5 (5.89)	116.5 (4.59)	74 (2.91)	7.5 (0.30)	10 (0.39)	59 (2.32)	84 (3.31)	85 (3.35)	36 (1.42)	38 (1.50)	26 (1.02)	36 (1.42)	32 (1.26)	20 (0.79)

3.6.5 SGMAJ Servomotors (3000 min^{-1}) With Low-backlash Gears and Without Brakes

Units: mm (in)

Model SGMAJ-	Gear Ratio	LC	LA	LZ	Tap×Depth *	U	W	T	Approx. Mass kg (lb)	Allowable Radial Load N (lbf)	Allowable Thrust Load N (lbf)
A5□□AH1□1	1/5	60 (2.36)	70 (2.76)	5.5 (0.22)	M4×8L	3 (0.12)	5 (0.20)	5 (0.20)	1.1 (2.4)	137 (31)	127 (29)
A5□□AH2□1	1/9	70 (2.76)	80 (3.15)	6.6 (0.26)	M4×8L	3 (0.12)	5 (0.20)	5 (0.20)	1.4 (3.1)	206 (47)	147 (33)
A5□□AHC□1	1/21	70 (2.76)	80 (3.15)	6.6 (0.26)	M4×8L	3 (0.12)	5 (0.20)	5 (0.20)	1.3 (2.9)	235 (53)	
A5□□AH7□1	1/33	70 (2.76)	80 (3.15)	6.6 (0.26)	M4×8L	3 (0.12)	5 (0.20)	5 (0.20)	1.3 (2.9)		
A8C□AH1□1	1/5	70 (2.76)	80 (3.15)	6.6 (0.26)	M4×8L	3 (0.12)	5 (0.20)	5 (0.20)	1.2 (2.7)	167 (38)	147 (33)
A8C□AHB□1	1/11	70 (2.76)	80 (3.15)	6.6 (0.26)	M4×8L	3 (0.12)	5 (0.20)	5 (0.20)	1.4 (3.1)	216 (49)	
A8C□AHC□1	1/21	90 (3.54)	105 (4.13)	9 (0.35)	M5×10L	3.5 (0.14)	6 (0.24)	6 (0.24)	2.7 (6.0)	392 (89)	235 (53)
A8C□AH7□1	1/33	90 (3.54)	105 (4.13)	9 (0.35)	M5×10L	3.5 (0.14)	6 (0.24)	6 (0.24)	2.7 (6.0)	431 (98)	
01E□AH1□1	1/5	70 (2.76)	80 (3.15)	6.6 (0.26)	M4×8L	3 (0.12)	5 (0.20)	5 (0.20)	1.2 (2.7)	167 (38)	147 (33)
01E□AHB□1	1/11	70 (2.76)	80 (3.15)	6.6 (0.26)	M4×8L	3 (0.12)	5 (0.20)	5 (0.20)	1.4 (3.1)	216 (49)	
01E□AHC□1	1/21	90 (3.54)	105 (4.13)	9 (0.35)	M5×10L	3.5 (0.14)	6 (0.24)	6 (0.24)	2.7 (6.0)	392 (89)	235 (53)
01E□AH7□1	1/33	90 (3.54)	105 (4.13)	9 (0.35)	M5×10L	3.5 (0.14)	6 (0.24)	6 (0.24)	2.7 (6.0)	431 (98)	



- The dimensions for L and LL of a servomotor incorporating an encoder with super-capacitor (model: SGMAJ-□□□4) are as shown below.

SGMAJ-A5, A8, and 01: L-dimension +12 mm (0.47 in), LL-dimension +12 mm (0.47 in)

- The working point of the SGMAJ servomotor radial load is at the position of minus 5 mm from the shaft end.

- Dimensional Tolerances

Units: mm (in)

Model SGMAJ-	Flange Face Dimensions	Shaft-end Dimensions
	LB	S
A5□□AH1□1	$56 \begin{matrix} 0 \\ -0.030 \end{matrix} \begin{matrix} (2.20 \\ -0.0012) \end{matrix}$	$14 \begin{matrix} 0 \\ -0.018 \end{matrix} \begin{matrix} (0.55 \\ -0.00071) \end{matrix}$
A5□□AH2□1	$65 \begin{matrix} 0 \\ -0.030 \end{matrix} \begin{matrix} (2.56 \\ -0.0012) \end{matrix}$	$16 \begin{matrix} 0 \\ -0.018 \end{matrix} \begin{matrix} (0.63 \\ -0.00071) \end{matrix}$
A5□□AHC□1	$65 \begin{matrix} 0 \\ -0.030 \end{matrix} \begin{matrix} (2.56 \\ -0.0012) \end{matrix}$	$16 \begin{matrix} 0 \\ -0.018 \end{matrix} \begin{matrix} (0.63 \\ -0.00071) \end{matrix}$
A5□□AH7□1	$65 \begin{matrix} 0 \\ -0.030 \end{matrix} \begin{matrix} (2.56 \\ -0.0012) \end{matrix}$	$16 \begin{matrix} 0 \\ -0.018 \end{matrix} \begin{matrix} (0.63 \\ -0.00071) \end{matrix}$
A8C□AH1□1	$65 \begin{matrix} 0 \\ -0.030 \end{matrix} \begin{matrix} (2.56 \\ -0.0012) \end{matrix}$	$16 \begin{matrix} 0 \\ -0.018 \end{matrix} \begin{matrix} (0.63 \\ -0.00071) \end{matrix}$
A8C□AHB□1	$65 \begin{matrix} 0 \\ -0.030 \end{matrix} \begin{matrix} (2.56 \\ -0.0012) \end{matrix}$	$16 \begin{matrix} 0 \\ -0.018 \end{matrix} \begin{matrix} (0.63 \\ -0.00071) \end{matrix}$

Units: mm (in) (cont'd)

Model SGMAJ-	Flange Face Dimensions	Shaft-end Dimensions
	LB	S
A8C□AHC□1	$85 \begin{smallmatrix} 0 \\ -0.035 \end{smallmatrix} \begin{pmatrix} 3.35 & 0 \\ -0.0014 & \end{pmatrix}$	$20 \begin{smallmatrix} 0 \\ -0.021 \end{smallmatrix} \begin{pmatrix} 0.79 & 0 \\ -0.00083 & \end{pmatrix}$
A8C□AH7□1	$85 \begin{smallmatrix} 0 \\ -0.035 \end{smallmatrix} \begin{pmatrix} 3.35 & 0 \\ -0.0014 & \end{pmatrix}$	$20 \begin{smallmatrix} 0 \\ -0.021 \end{smallmatrix} \begin{pmatrix} 0.79 & 0 \\ -0.00083 & \end{pmatrix}$
01E□AH1□1	$65 \begin{smallmatrix} 0 \\ -0.030 \end{smallmatrix} \begin{pmatrix} 2.56 & 0 \\ -0.0012 & \end{pmatrix}$	$16 \begin{smallmatrix} 0 \\ -0.018 \end{smallmatrix} \begin{pmatrix} 0.63 & 0 \\ -0.00071 & \end{pmatrix}$
01E□AHB□1	$65 \begin{smallmatrix} 0 \\ -0.030 \end{smallmatrix} \begin{pmatrix} 2.56 & 0 \\ -0.0012 & \end{pmatrix}$	$16 \begin{smallmatrix} 0 \\ -0.018 \end{smallmatrix} \begin{pmatrix} 0.63 & 0 \\ -0.00071 & \end{pmatrix}$
01E□AHC□1	$85 \begin{smallmatrix} 0 \\ -0.035 \end{smallmatrix} \begin{pmatrix} 3.35 & 0 \\ -0.0014 & \end{pmatrix}$	$20 \begin{smallmatrix} 0 \\ -0.021 \end{smallmatrix} \begin{pmatrix} 0.79 & 0 \\ -0.00083 & \end{pmatrix}$
01E□AH7□1	$85 \begin{smallmatrix} 0 \\ -0.035 \end{smallmatrix} \begin{pmatrix} 3.35 & 0 \\ -0.0014 & \end{pmatrix}$	$20 \begin{smallmatrix} 0 \\ -0.021 \end{smallmatrix} \begin{pmatrix} 0.79 & 0 \\ -0.00083 & \end{pmatrix}$

(2) 200 W, 300 W

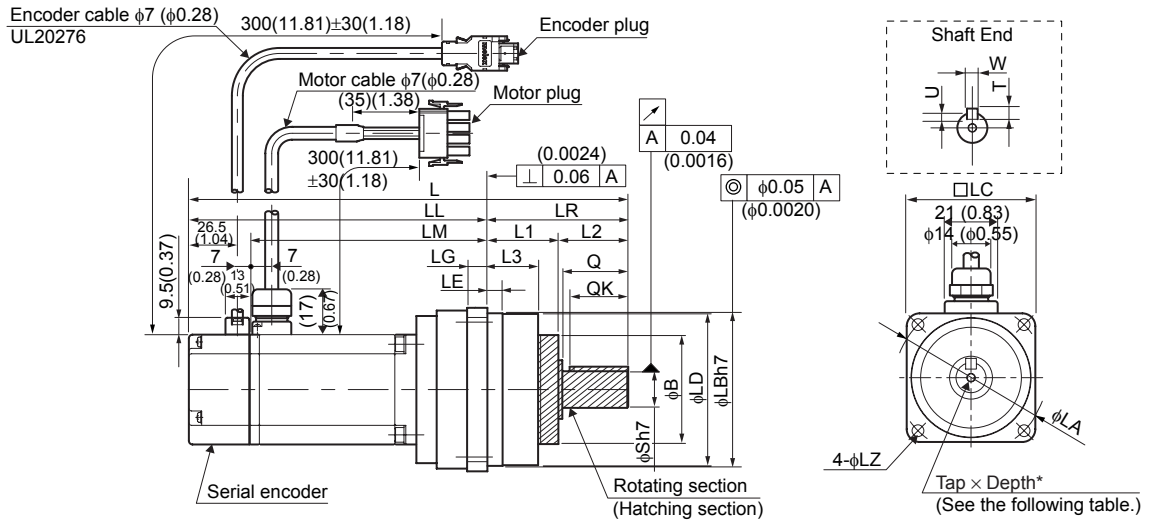

Units: mm (in)

Model SGMAJ-	Gear Ratio	L	LL	LM	LR	LE	LG	B	LD	LB	L1	L2	L3	Q	QK	S
02E□AH1□1	1/5	208.5 (8.21)	134.5 (5.30)	101 (3.98)	74 (2.91)	7.5 (0.30)	10 (0.39)	59 (2.32)	84 (3.31)	85 (3.35)	36 (1.42)	38 (1.50)	26 (1.02)	36 (1.42)	32 (1.26)	20 (0.79)
02E□AHB□1	1/11	225.5 (8.88)	151.5 (5.97)	118 (4.65)	74 (2.91)	7.5 (0.30)	10 (0.39)	59 (2.32)	84 (3.31)	85 (3.35)	36 (1.42)	38 (1.50)	26 (1.02)	36 (1.42)	32 (1.26)	20 (0.79)
02E□AHC□1	1/21	243.5 (9.59)	159.5 (6.28)	126 (4.96)	84 (3.31)	12 (0.47)	12 (0.47)	59 (2.32)	96 (3.78)	100 (3.94)	40 (1.57)	44 (1.73)	29 (1.14)	42 (1.65)	36 (1.42)	25 (0.98)
02E□AH7□1	1/33	243.5 (9.59)	159.5 (6.28)	126 (4.96)	84 (3.31)	12 (0.47)	12 (0.47)	59 (2.32)	96 (3.78)	100 (3.94)	40 (1.57)	44 (1.73)	29 (1.14)	42 (1.65)	36 (1.42)	25 (0.98)
03E□AH1□1	1/5	236.5 (9.31)	162.5 (6.40)	129 (5.08)	74 (2.91)	7.5 (0.30)	10 (0.39)	59 (2.32)	84 (3.31)	85 (3.35)	36 (1.42)	38 (1.50)	26 (1.02)	36 (1.42)	32 (1.26)	20 (0.79)
03E□AHB□1	1/11	271.5 (10.69)	187.5 (7.38)	154 (6.06)	84 (3.31)	12 (0.47)	12 (0.47)	59 (2.32)	96 (3.78)	100 (3.94)	40 (1.57)	44 (1.73)	29 (1.14)	42 (1.65)	36 (1.42)	25 (0.98)
03E□AHC□1	1/21	300.5 (11.83)	195.5 (7.70)	162 (6.38)	105 (4.13)	14 (0.55)	13 (0.51)	59 (2.32)	112 (4.41)	115 (4.53)	45 (1.77)	60 (2.36)	33 (1.30)	58 (2.28)	50 (1.97)	32 (1.26)
03E□AH7□1	1/33	300.5 (11.83)	195.5 (7.70)	162 (6.38)	105 (4.13)	12.5 (0.49)	13 (0.51)	84 (3.31)	114 (4.49)	115 (4.53)	45 (1.77)	60 (2.36)	33 (1.30)	58 (2.28)	50 (1.97)	32 (1.26)

3.6.5 SGMAJ Servomotors (3000 min⁻¹) With Low-backlash Gears and Without Brakes

Units: mm (in)

Model SGMAJ-	Gear Ratio	LC	LA	LZ	Tap×Depth *	U	W	T	Approx. Mass kg (lb)	Allowable Radial Load N (lbf)	Allowable Thrust Load N (lbf)
02E□AH1□1	1/5	90 (3.54)	105 (4.13)	9 (0.35)	M5×10L	3.5 (0.14)	6 (0.24)	6 (0.24)	3.0 (6.6)	245 (56)	235 (53)
02E□AHB□1	1/11	90 (3.54)	105 (4.13)	9 (0.35)	M5×10L	3.5 (0.14)	6 (0.24)	6 (0.24)	3.5 (7.7)	323 (73)	
02E□AHC□1	1/21	105 (4.13)	120 (4.72)	9 (0.35)	M6×12L	4 (0.16)	8 (0.31)	7 (0.28)	3.7 (8.2)	549 (124)	294 (67)
02E□AH7□1	1/33	105 (4.13)	120 (4.72)	9 (0.35)	M6×12L	4 (0.16)	8 (0.31)	7 (0.28)	3.8 (8.4)	608 (138)	
03E□AH1□1	1/5	90 (3.54)	105 (4.13)	9 (0.35)	M5×10L	3.5 (0.14)	6 (0.24)	6 (0.24)	3.6 (7.9)	245 (56)	235 (53)
03E□AHB□1	1/11	105 (4.13)	120 (4.72)	9 (0.35)	M6×12L	4 (0.16)	8 (0.31)	7 (0.28)	4.3 (9.5)	441 (100)	294 (67)
03E□AHC□1	1/21	120 (4.72)	135 (5.31)	11 (0.43)	M8×16L	5 (0.20)	10 (0.39)	8 (0.31)	4.7 (10.4)	568 (129)	314 (71)
03E□AH7□1	1/33	120 (4.72)	135 (5.31)	11 (0.43)	M8×16L	5 (0.20)	10 (0.39)	8 (0.31)	7.1 (15.7)	657 (149)	



- The dimensions for L and LL of a servomotor incorporating an encoder with super-capacitor (model: SGMAJ-□□□4) are as shown below.

SGMAJ-02 and 03: L-dimension + 8.2 mm (0.32 in), LL-dimension + 8.2 mm (0.32 in)

- The working point of the SGMAJ servomotor radial load is at the position of minus 5 mm from the shaft end.

- Dimensional Tolerances

Units: mm (in)

Model SGMAJ-	Flange Face Dimensions	Shaft-end Dimensions
	LB	S
02E□AH1□1	$85 \begin{matrix} 0 \\ -0.035 \end{matrix} \begin{pmatrix} 3.35 & 0 \\ & -0.0014 \end{pmatrix}$	$20 \begin{matrix} 0 \\ -0.021 \end{matrix} \begin{pmatrix} 0.79 & 0 \\ & -0.0008 \end{pmatrix}$
02E□AHB□1	$85 \begin{matrix} 0 \\ -0.035 \end{matrix} \begin{pmatrix} 3.35 & 0 \\ & -0.0014 \end{pmatrix}$	$20 \begin{matrix} 0 \\ -0.021 \end{matrix} \begin{pmatrix} 0.79 & 0 \\ & -0.0008 \end{pmatrix}$
02E□AHC□1	$100 \begin{matrix} 0 \\ -0.035 \end{matrix} \begin{pmatrix} 3.94 & 0 \\ & -0.0014 \end{pmatrix}$	$25 \begin{matrix} 0 \\ -0.021 \end{matrix} \begin{pmatrix} 0.98 & 0 \\ & -0.0008 \end{pmatrix}$
02E□AH7□1	$100 \begin{matrix} 0 \\ -0.035 \end{matrix} \begin{pmatrix} 3.94 & 0 \\ & -0.0014 \end{pmatrix}$	$25 \begin{matrix} 0 \\ -0.021 \end{matrix} \begin{pmatrix} 0.98 & 0 \\ & -0.0008 \end{pmatrix}$
03E□AH1□1	$85 \begin{matrix} 0 \\ -0.035 \end{matrix} \begin{pmatrix} 3.35 & 0 \\ & -0.0014 \end{pmatrix}$	$20 \begin{matrix} 0 \\ -0.021 \end{matrix} \begin{pmatrix} 0.79 & 0 \\ & -0.0008 \end{pmatrix}$
03E□AHB□1	$100 \begin{matrix} 0 \\ -0.035 \end{matrix} \begin{pmatrix} 3.94 & 0 \\ & -0.0014 \end{pmatrix}$	$25 \begin{matrix} 0 \\ -0.021 \end{matrix} \begin{pmatrix} 0.98 & 0 \\ & -0.0008 \end{pmatrix}$
03E□AHC□1	$115 \begin{matrix} 0 \\ -0.035 \end{matrix} \begin{pmatrix} 4.53 & 0 \\ & -0.0014 \end{pmatrix}$	$32 \begin{matrix} 0 \\ -0.025 \end{matrix} \begin{pmatrix} 1.26 & 0 \\ & -0.0010 \end{pmatrix}$
03E□AH7□1	$115 \begin{matrix} 0 \\ -0.035 \end{matrix} \begin{pmatrix} 4.53 & 0 \\ & -0.0014 \end{pmatrix}$	$32 \begin{matrix} 0 \\ -0.025 \end{matrix} \begin{pmatrix} 1.26 & 0 \\ & -0.0010 \end{pmatrix}$

3.7 Dimensional Drawing of Output Shafts With Oil Seals

For the SGMAJ servomotors with oil seals, the external dimensions of output shafts differ as shown below.

Model		SGMAJ-A5, A8, 01	SGMAJ-02, 03
Capacity		50 W to 100 W	200 to 300 W
Dimensions of Output Shaft mm (in)	LO	7.5 (0.30)	10 (0.39)
	DO	$\phi 28$ ($\phi 1.10$)	$\phi 48$ ($\phi 1.89$)
	QK	14 (0.55)	14 (0.55)
	LB	$\phi 30 \begin{smallmatrix} 0 \\ -0.021 \end{smallmatrix}$ ($\phi 1.181 \begin{smallmatrix} 0 \\ -0.00083 \end{smallmatrix}$)	$\phi 50 \begin{smallmatrix} 0 \\ -0.025 \end{smallmatrix}$ ($\phi 1.9685 \begin{smallmatrix} 0 \\ -0.00098 \end{smallmatrix}$)
Dimensional Drawing			

SERVOPACK Specifications and Dimensional Drawings

4.1 SERVOPACK Ratings and Specifications	4-2
4.1.1 SERVOPACK Ratings and Specifications 1	4-2
4.1.2 SERVOPACK Ratings and Specifications 2	4-3
4.2 SERVOPACK Installation	4-5
4.3 SERVOPACK Internal Block Diagrams	4-7
4.3.1 Speed and Torque Control (SGDJ-□□□S)	4-7
4.3.2 Position Control (SGDJ-□□□P)	4-8
4.4 SERVOPACK's Power Supply Capacities and Power Losses	4-9
4.5 SERVOPACK Overload Characteristics and Allowable Load	
Moment of Inertia	4-10
4.5.1 Overload Characteristics	4-10
4.5.2 Starting and Stopping Time	4-11
4.5.3 Load Moment of Inertia	4-11
4.5.4 Overhanging Loads	4-12
4.6 Dimensional Drawings	4-13
4.6.1 24 VDC: 10/50 W (A1C□/A5C□)	
48 VDC: 50 W to 200 W (A5E□ to 02E□)	4-13
4.6.2 24 VDC: 80 W (A8C□)	
48 VDC: 300 W (03E□)	4-13

4.1 SERVOPACK Ratings and Specifications

CAUTION

- Take appropriate measures to ensure that the input power supply is supplied within the specified voltage range.
An incorrect input power supply may result in damage to the SERVOPACK. Be sure to set the voltage within the specified range.

4.1.1 SERVOPACK Ratings and Specifications 1

Power Supply Voltage		24 VDC		48 VDC			
SERVOPACK Model SGDJ-		A5CS	A8CS	A5ES	01ES	02ES	03ES
		A5CP	A8CP	A5EP	01EP	02EP	03EP
Input Power Supply	Main Circuit	24 VDC \pm 15%		48 VDC \pm 15%			
	Control Circuit	24 VDC \pm 15%		48 VDC \pm 15%			
Input Current [Arms]		4.0	6.0	1.9	3.5	6.7	9.7
Output Current	Continuous Output Current [Arms]	3.2	6.5	2.1	2.8	6.4	8.6
	Max. Output Current [Arms]	6.6	13.3	4.5	5.7	12.6	16.8

Refer to 2.3 SGDJ SERVOPACKs and Applicable Servomotors for applicable servomotors.

4.1.2 SERVOPACK Ratings and Specifications 2

Item		Ratings and Specifications		SGDJ-				
				□□□□S	□□□□P			
Basic Specifications	Control Method		MOSFET-PWM method		Applicable	Applicable		
	Feedback		Serial encoder: 13, 16 or 17-bit (incremental/absolute) * The 13-bit encoder is incremental only.		Applicable	Applicable		
	Condi-tions	Ambient/Storage Temperature *1		0 °C to 40 °C (32 °F to 104 °F) (Including the internal panel use)/-20 °C to +85 °C (-4 °F to 185 °F)		Applicable	Applicable	
		Ambient/Storage Humidity		90% RH or less (with no condensation)		Applicable	Applicable	
		Vibration/Shock Resistance		9.8 m/s ² /147 m/s ²		Applicable	Applicable	
Speed and Torque Control Modes	Speed Control Range		1:5000 (The lowest speed of the speed control range is the speed at which the servomotor will not stop with a rated torque load.)		Applicable	N/A		
	Perfor-mance	Speed Regula-tion *2	Load Regulation		0 to 100% load: ±0.01% or less (at rated speed)		Applicable	N/A
			Voltage Regulation		Rated voltage ±10%: 0% (at rated speed)		Applicable	N/A
			Temperature Regula-tion		25 ± 25 °C (77 °F): ±0.1% or less (at rated speed)		Applicable	N/A
	Frequency Characteristics		400 Hz (at J _L = J _M)		Applicable	N/A		
	Torque Control Tolerance (Repeatability)		±2%		Applicable	N/A		
	Soft Start Time Setting		0 to 10 s (Can be set individually for acceleration and deceleration.)		Applicable	N/A		
	Input Signals	Speed Reference Input	Reference Voltage *3		±6 VDC (Variable setting range: ±2 to ±10 VDC) at rated torque (servomotor forward rotation with positive reference), input voltage: maximum ±12 V		Applicable	N/A
			Input Impedance		About 14 kΩ		Applicable	N/A
			Circuit Time Constant		About 47 μs		Applicable	N/A
		Torque Reference Input	Reference Voltage *3		±3 VDC (Variable setting range: ±1 to ±10 VDC) at rated torque (positive torque reference with positive reference), input voltage: maximum ±12 V		Applicable	N/A
			Input Impedance		About 14 kΩ		Applicable	N/A
			Circuit Time Constant		About 47 μs		Applicable	N/A
	Contact Speed Reference	Rotation Direction Selection		With P control signal		Applicable	N/A	
		Speed Selection		With forward/reverse current limit signal (speed 1 to 3 selection), servomotor stops or another control method is used when both are OFF.		Applicable	N/A	
Position Control Modes	Perfor-mance	Bias Setting		0 to 450 min ⁻¹ (setting resolution: 1 min ⁻¹)		N/A	Applicable	
		Feed Forward Compensation		0 to 100% (setting resolution: 1%)		N/A	Applicable	
		Positioning Completed Width Setting		0 to 250 reference units (setting resolution: 1 reference unit)		N/A	Applicable	
	Input Signals	Reference Pulse	Type		Sign + pulse train, 90° phase difference 2-phase pulse (phase A + phase B), or CCW + CW pulse train		N/A	Applicable
			Form		Line driver (+5 V level), open collector (+5 V or +12 V level)		N/A	Applicable
			Frequency		Maximum 500/200 kpps (line driver/open collector)		N/A	Applicable
	Control Signal		Clear signal (input pulse form identical to reference pulse)		N/A	Applicable		

(cont'd)

Item			Ratings and Specifications	SGDJ-		
				□□□S	□□□P	
I/O Signals	Position Output	Form	Phase-A, -B, -C line driver Phase-S line driver (only with an absolute encoder)	Applicable	Applicable	
		Frequency Dividing Ratio	Any	Applicable	Applicable	
	Sequence Input	Signal allocation can be modified.	Servo ON, P control (or Control mode switching, forward/reverse motor rotation by internal speed setting, zero clamping, reference pulse prohibited), forward run prohibited (P-OT), reverse run prohibited (N-OT), alarm reset, forward current limit, and reverse current limit (or internal speed selection)	Applicable	Applicable	
	Sequence Output	Fixed Output	Servo alarm, 3-bit alarm codes	Applicable	Applicable	
		Signal allocation can be modified.	Positioning completed (speed coincidence), during servomotor rotation, servo ready, during current limiting, during speed limiting, brake released, warning, selecting three of the NEAR signals.	Applicable	Applicable	
Internal Functions	Dynamic Brake		Operated at main power OFF, servo alarm, servo OFF or overtravel.	Applicable	Applicable	
	Overtravel Stop		Dynamic brake stop at P-OT or N-OT, deceleration to a stop, or coast to a stop	Applicable	Applicable	
	Electronic Gear		$0.01 \leq B/A \leq 100$	N/A	Applicable	
	Protection		Overcurrent, overvoltage, overload, regeneration error, main circuit detection section error, heat sink overheated, no power supply, overflow, overspeed, encoder error, overrun, CPU error, parameter error.	Applicable	Applicable	
	LED Display		Charge, Power	Applicable	Applicable	
	CN5 Analog Monitoring		Analog monitor connector built in for monitoring speed, torque and other reference signals. Speed: $1 \text{ V}/1000 \text{ min}^{-1}$ Torque: $1 \text{ V}/100\%$ of rated torque Position error pulses: $0.05 \text{ V}/1$ reference units or $0.05 \text{ V}/100$ reference units	Applicable	Applicable	
	Communications	Connected Devices		Digital Operator (hand-held model), RS-422A port such as for a personal computer (RS-232C ports under certain conditions)	Applicable	Applicable
		1:N Communications		Up to $N = 14$ for RS-422A ports	Applicable	Applicable
		Axis Address Setting		Set with parameters.	Applicable	Applicable
		Functions		Status display, parameter setting, monitor display, alarm trace-back display, JOG and autotuning operations, speed, torque reference signal and other drawing functions.	Applicable	Applicable
Others		Reverse rotation connection, zero-point search, automatic servomotor ID.	Applicable	Applicable		

* 1. Use the SERVOPACK within the ambient temperature range. When enclosed in a control panel, internal temperatures must not exceed the ambient temperature range.

* 2. Speed regulation is defined as follows:

$$\text{Speed regulation} = \frac{\text{No-load motor speed} - \text{Total load motor speed}}{\text{Rated motor speed}} \times 100\%$$

The motor speed may change due to voltage variations or amplifier drift and changes in processing resistance due to temperature variation. The ratio of speed changes to the rated speed represent speed regulation due to voltage and temperature variations.

* 3. Forward is clockwise viewed from the non-load side of the servomotor. (Counterclockwise viewed from the load and shaft end)

4.2 SERVOPACK Installation

The SGDJ SERVOPACKs can be mounted on a compact servo amplifier with a book-end design. Incorrect installation will cause problems. Always observe the following installation instructions.

WARNING

- Connect the main circuit wires, control wires, and main circuit cables of the motor correctly. Incorrect wiring will result in failure of the SERVOPACK.

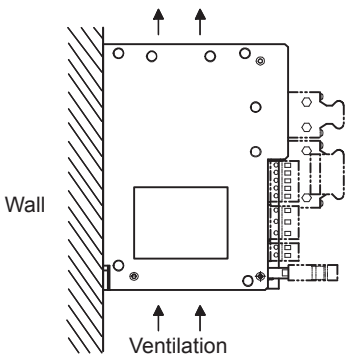
Storage	<p>Store the SERVOPACK within the following temperature range if it is stored with the power cable disconnected.</p> <p>Temperature: -20 to 85 °C (-4 to 185 °F) Humidity: 90%RH or less (with no condensation)</p>
Operating Conditions	<ul style="list-style-type: none"> • Protection class * : 1X • Altitude : Maximum 1000 m
Installation Site	<p>Installation in a Control Panel Design the control panel size, unit layout, and cooling method so the temperature around the SERVOPACK does not exceed 40 °C (104 °F).</p> <p>Installation Near a Heating Unit Minimize the heat radiating from the heating unit as well as any temperature rise caused by natural convection so the temperature around the SERVOPACK does not exceed 40 °C (104 °F).</p> <p>Installation Near a Source of Vibration Install a vibration isolator on the SERVOPACK to avoid subjecting it to vibration.</p> <p>Installation at a Site Exposed to Corrosive Gas Corrosive gas does not have an immediate effect on the SERVOPACK but will eventually cause the electronic components and contactor-related devices to malfunction. Take appropriate action to avoid corrosive gas.</p> <p>Other Situations Do not install the SERVOPACK in hot, humid locations or locations subject to excessive dust or iron powder in the air.</p>
Orientation	<p>Install the SERVOPACK perpendicular to the wall as shown in the figure. The SERVOPACK must be oriented this way because it is designed to be cooled by natural convection or a cooling fan.</p> <p>Secure the SERVOPACK using three or four mounting holes. The number of holes depends on the capacity.</p> 

* Conforming to the following standards.

- UL508C
- CSA C22.2 No.14
- EN50178
- EN55011 group 1 class A
- EN61000-6-2

Installation	<p>Follow the procedure below to install multiple SERVOPACKs side by side in a control panel.</p>
	<p>The diagram illustrates the side-by-side installation of four SERVOPACKs. Two cooling fans are positioned above the units, with arrows indicating airflow. Dimension lines specify the following clearances: 30 mm (1.18 in) min. between the first two units, 10 mm (0.39 in) min. between the two pairs, and 50 mm (1.97 in) min. clearance above and below each unit.</p>
	<p>SERVOPACK Orientation Install the SERVOPACK perpendicular to the wall so the front panel containing connectors faces outward.</p> <p>Cooling As shown in the figure above, allow sufficient space around each SERVOPACK for cooling by cooling fans or natural convection.</p> <p>Side-by-side Installation When installing SERVOPACKs side by side as shown in the figure above, allow at least 10 mm (0.39 in) between and at least 50 mm (1.97 in) above and below each SERVOPACK. Install cooling fans above the SERVOPACKs to avoid excessive temperature rise and to maintain even temperature inside the control panel.</p> <p>Environmental Conditions in the Control Panel Ambient Temperature: 0 to 40 °C (32 to 104 °F) Humidity: 90% RH or less Vibration: 9.8 m/s² Condensation and Freezing: None Ambient Temperature for Long-term Reliability: 40 °C (104 °F) or less</p>

4.3 SERVOPACK Internal Block Diagrams

4.3.1 Speed and Torque Control (SGDJ-□□□S)

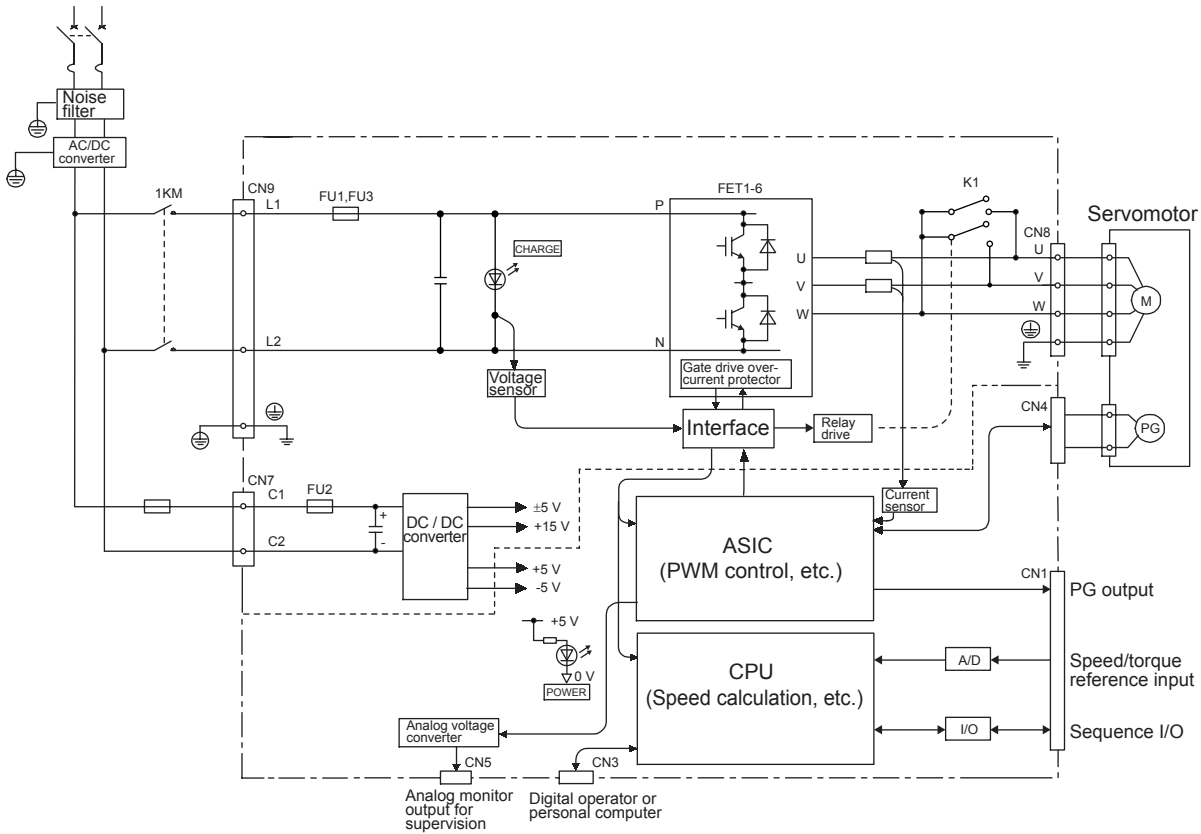

4

4.3.2 Position Control (SGDJ-□□□P)

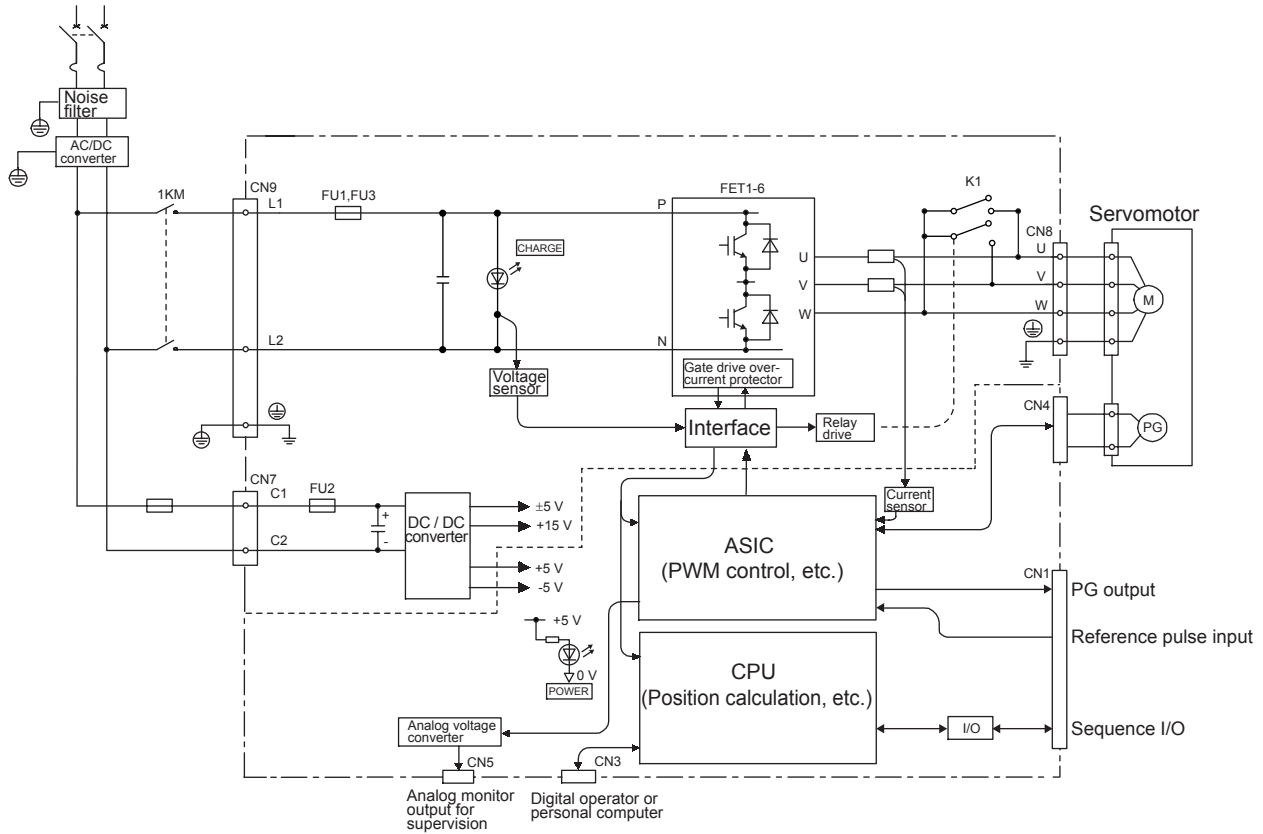

4.4 SERVOPACK's Power Supply Capacities and Power Losses

The following table shows SERVOPACK's power supply capacities and power losses at the rated output.

SERVOPACK Model SGDJ-	Input		Output			Power Loss		
	Voltage	Current	Continuous Current [Arms]	Max. Current [Arms]	Rated Output [kW]	Main Circuit Loss [W]	Control Circuit Loss [W]	Total Power Loss [W]
A5C□	24 VDC	4.0	3.2	6.6	0.05	7	9	16
A8C□		6.0	6.5	13.3	0.08	10	9	19
A5E□	48 VDC	1.9	2.1	4.5	0.55	6	8	14
01E□		3.5	2.8	5.7	0.1	10	8	18
02E□		6.7	6.4	12.6	0.2	20	8	28
03E□		9.7	8.6	16.8	0.3	30	8	38

4.5 SERVOPACK Overload Characteristics and Allowable Load Moment of Inertia

4.5.1 Overload Characteristics

SERVOPACKs have a built-in overload protective function that protects the SERVOPACKs and servomotors from overload. Allowable power for the SERVOPACKs is limited by the overload protective function as shown in the figure below.

The overload detection level is set under hot start conditions at a servomotor ambient temperature of 40°C (104°F).

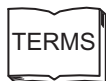
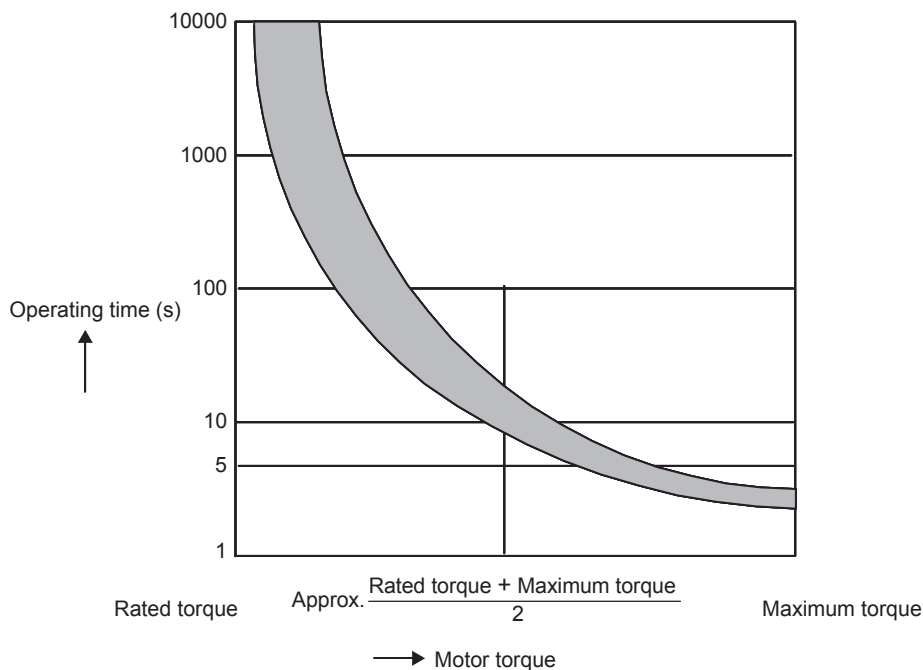

Hot Start

A hot start indicates that both the SERVOPACK and the servomotor have run long enough at the rated load to be thermally saturated.

4.5.2 Starting and Stopping Time

The motor starting time (t_r) and stopping time (t_f) under a constant load are calculated using the following formulas. Motor viscous torque and friction torque are ignored.

$$\text{Starting time: } t_r = \frac{2\pi \cdot N_M (J_M + J_L)}{60 \cdot (T_{PM} \cdot T_L)} [\text{s}]$$

$$\text{Stopping time: } t_f = \frac{2\pi \cdot N_M (J_M + J_L)}{60 \cdot (T_{PM} \cdot T_L)} [\text{s}]$$

N_M : Motor speed (min^{-1})

J_M : Motor rotor moment of inertia ($\text{kg}\cdot\text{m}^2$)

J_L : Load converted to shaft moment of inertia ($\text{kg}\cdot\text{m}^2$)

T_{PM} : Instantaneous peak motor torque when combined with a SERVOPACK ($\text{N}\cdot\text{m}$)

T_L : Load torque ($\text{N}\cdot\text{m}$)

Calculate the torque from the motor current using servomotor torque constant \times motor current (effective value).

The following figure shows the motor torque and motor speed timing chart.

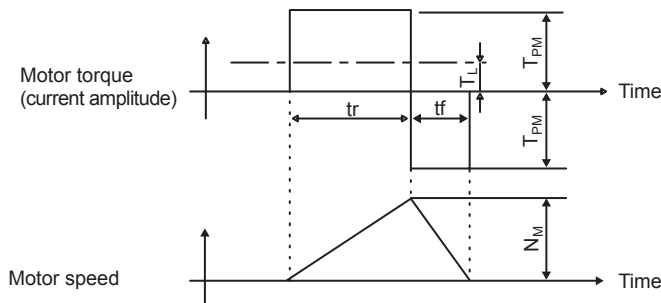

4.5.3 Load Moment of Inertia

The larger the load moment of inertia, the worse the movement response of the load.

The size of the load moment of inertia (J_L) allowable when using a servomotor depends on motor capacity and is limited to within 30 times the moment of inertia of each servomotor (J_M). This value is provided strictly as a guideline and results may vary depending on servomotor drive conditions.

An overvoltage alarm is likely to occur during deceleration if the load moment of inertia exceeds the allowable load moment of inertia. Take one of the following steps if this occurs.

- Reduce the torque limit.
- Reduce the deceleration rate.
- Reduce the maximum motor speed.

4.5.4 Overhanging Loads

A servomotor may not be operated with an overhanging load, which tends to continuously rotate the motor. *Fig. 4.1* shows a typical example of such a load.

- DO NOT use the servomotor with the Vertical Axis Motor Drive without Counterweight

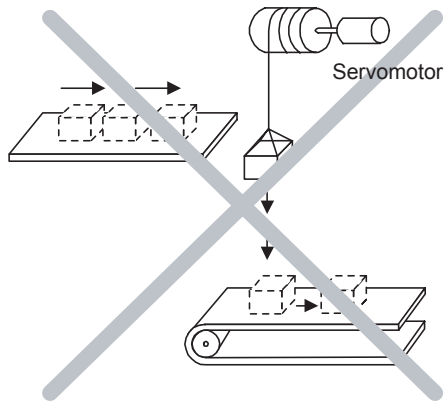

- DO NOT use the servomotor with the Feeding Motor Drive

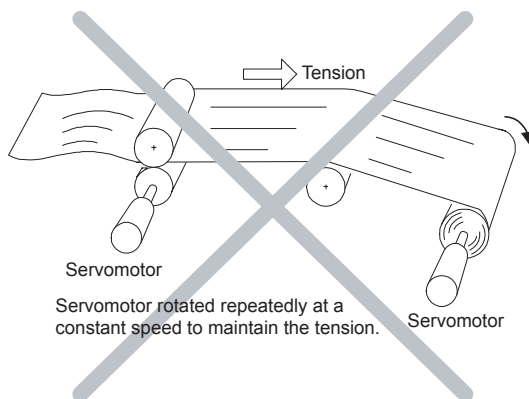

Fig 4.1 Examples of Overhanging Loads

IMPORTANT

- Never operate servomotors with an overhanging load. Doing so will cause the SERVOPACKs' regenerative brake to be applied continuously and the regenerative energy of the load may exceed the allowable range causing damage to the SERVOPACK.
- The regenerative brake capacity of the SGDM SERVOPACKs is rated for short-term operation approximately equivalent to the time it takes to decelerate to a stop.

4.6 Dimensional Drawings

4.6.1 24 VDC: 10/50 W (A1C□/A5C□) 48 VDC: 50 W to 200 W (A5E□ to 02E□)

External dimensions common to all SERVOPACKs for speed, torque, and position control are shown in the following diagrams.

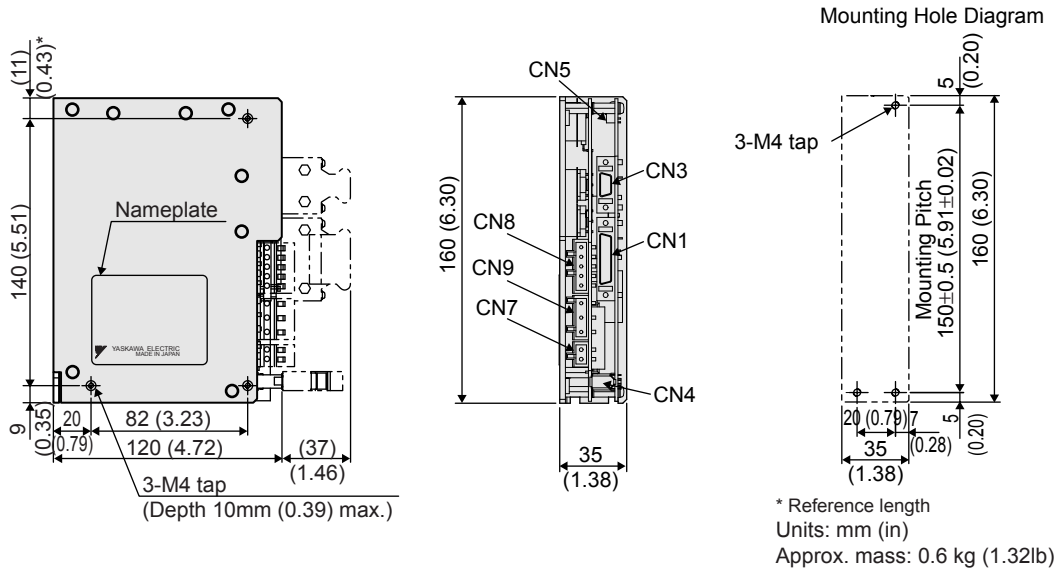

Note: The terminal block connector is not attached to the SGDJ SERVOPACK. The terminal block connector must be provided by customer.

4.6.2 24 VDC: 80 W (A8C□) 48 VDC: 300 W (03E□)

External dimensions common to all SERVOPACKs for speed, torque, and position control are shown in the following diagrams.

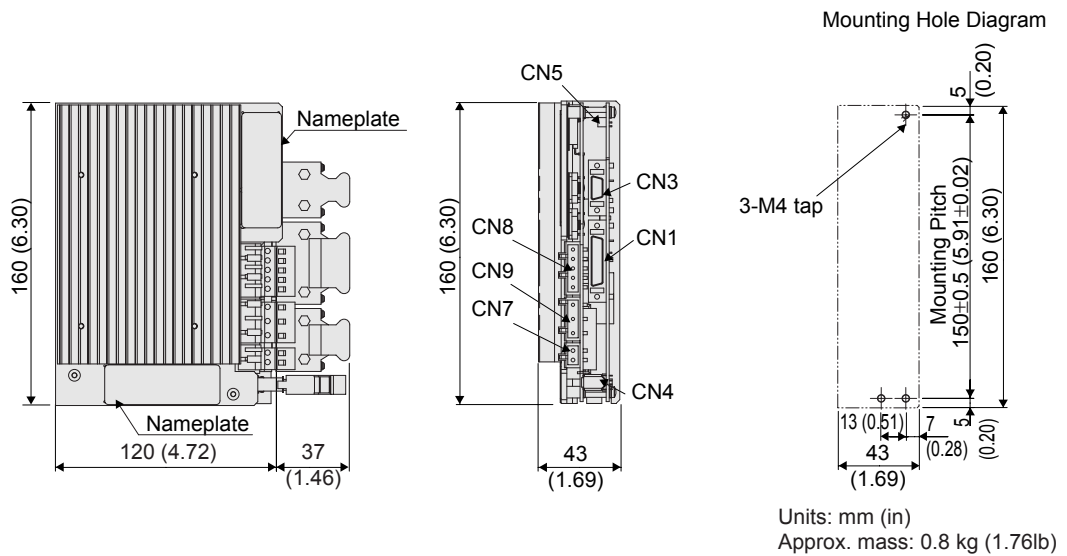

Note: The terminal block connector is not attached to the SGDJ SERVOPACK. The terminal block connector must be provided by customer.

Specifications and Dimensional Drawings of Cables and Peripheral Devices

5.1 Specifications and Dimensional Drawings of Servomotor	
Main Circuit Cable	5-2
5.1.1 Cables for SGMMJ and SGMAJ Servomotors Without Brakes	5-2
5.1.2 Cables for SGMMJ and SGMAJ Servomotors With Brakes	5-3
5.2 Servomotor and SERVOPACK Main Circuit Wire Size and Connectors	5-4
5.2.1 Wire Size	5-4
5.2.2 SGMMJ Servomotor Connectors for Standard Environments	5-5
5.2.3 SGMAJ Servomotor Connectors for Standard Environments	5-6
5.3 Encoder Cables for CN4 Connector	5-10
5.3.1 Encoder Cable With Connectors	5-10
5.3.2 Encoder Cable With a SERVOPACK Connector and Encoder Loose Leads	5-10
5.4 Connectors and Cables for Encoder Signals	5-11
5.4.1 Connectors and Cables	5-11
5.5 I/O Signal Cables for CN1 Connector	5-13
5.5.1 Standard Cables	5-13
5.5.2 Connector Type and Cable Size	5-13
5.5.3 Connection Diagram	5-15
5.6 Peripheral Devices	5-16
5.6.1 Cables for Connecting Personal Computers	5-16
5.6.2 Digital Operator	5-17
5.6.3 Cables for Analog Monitor	5-18
5.6.4 Connector Terminal Block Converter Unit	5-19
5.6.5 Noise Filter	5-21
5.6.6 Surge Suppressor	5-21
5.6.7 Variable Resistor for Speed and Torque Setting	5-21
5.6.8 Encoder Signal Converter Unit	5-22

5.1.1 Cables for SGMMJ and SGMAJ Servomotors Without Brakes

5.1 Specifications and Dimensional Drawings of Servomotor Main Circuit Cable

When assembling the servomotor main circuit cable, refer to 5.2 *Servomotor and SERVOPACK Main Circuit Wire Size and Connectors*.

5.1.1 Cables for SGMMJ and SGMAJ Servomotors Without Brakes

(1) SGMMJ

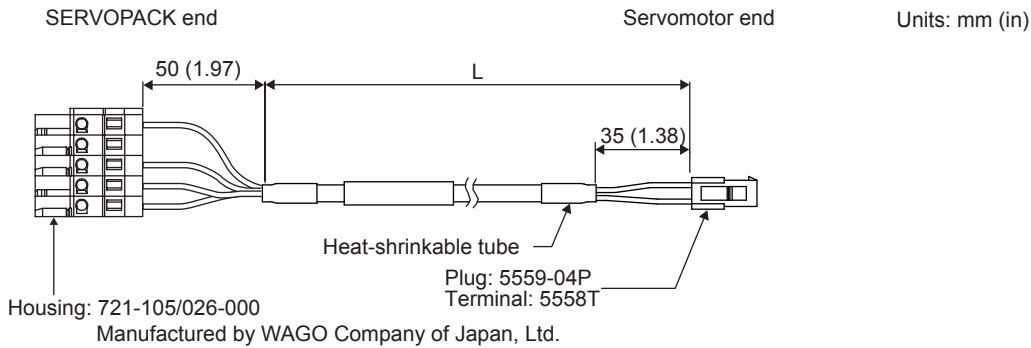

Units: m (ft)

Cable Type	Cable Length (L)
JZSP-CDM00-03	3 (9.84)
JZSP-CDM00-05	5 (16.40)
JZSP-CDM00-10	10 (32.81)
JZSP-CDM00-15	15 (49.21)
JZSP-CDM00-20	20 (65.62)

(2) SGMAJ

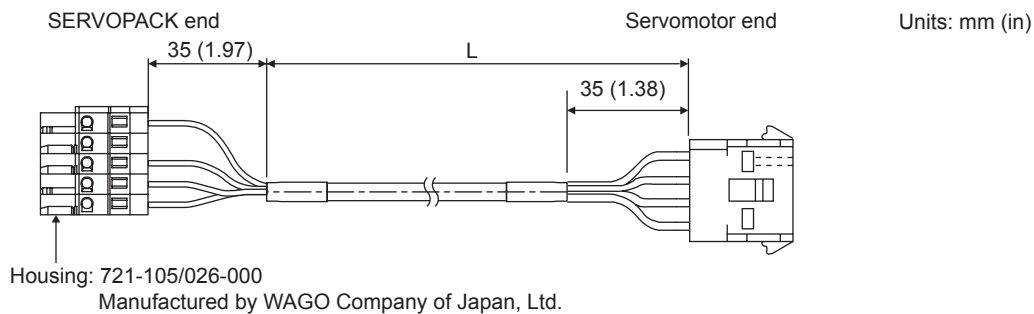

Units: m (ft)

Cable Type	Cable Length (L)
JZSP-CJM00-03	3 (9.84)
JZSP-CJM00-05	5 (16.40)
JZSP-CJM00-10	10 (32.81)
JZSP-CJM00-15	15 (49.21)
JZSP-CJM00-20	20 (65.62)

5.1.2 Cables for SGMMJ and SGMAJ Servomotors With Brakes

(1) SGMMJ

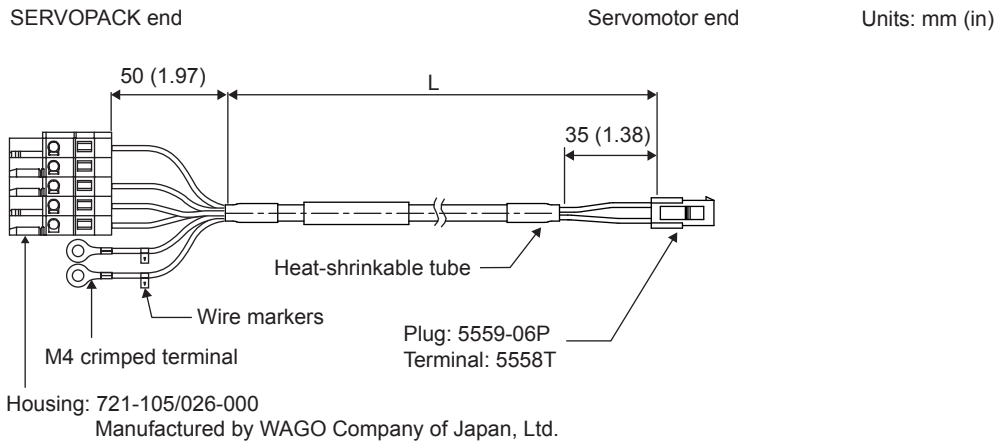

Units: m (ft)

Cable Type	Cable Length (L)
JZSP-CDM10-03	3 (9.84)
JZSP-CDM10-05	5 (16.40)
JZSP-CDM10-10	10 (32.81)
JZSP-CDM10-15	15 (49.21)
JZSP-CDM10-20	20 (65.62)

(2) SGMAJ

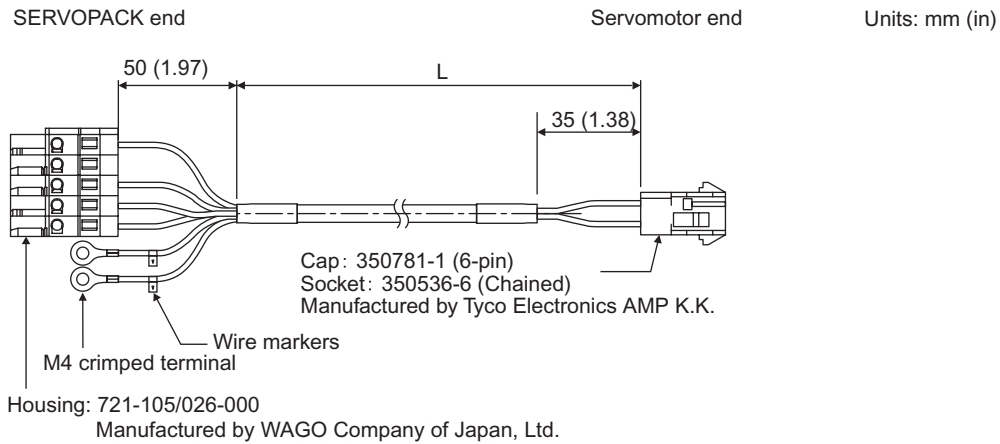

Units: m (ft)

Cable Type	Cable Length (L)
JZSP-CJM10-03	3 (9.84)
JZSP-CJM10-05	5 (16.40)
JZSP-CJM10-10	10 (32.81)
JZSP-CJM10-15	15 (49.21)
JZSP-CJM10-20	20 (65.62)

5.2 Servomotor and SERVOPACK Main Circuit Wire Size and Connectors

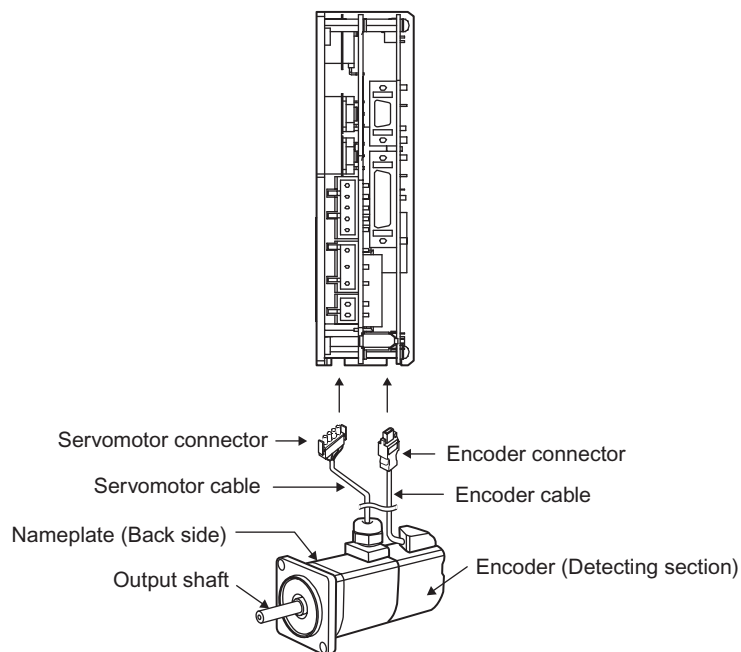

5.2.1 Wire Size

SERVOPACK Model SGDJ-	Main Circuit Power Input Terminal (CN9)	Motor Connection Terminal (CN8)	Control Power Input Terminal (CN7)
A5C□	AWG16 (HIV1.25) or more	AWG16 (HIV1.25) or more	AWG16 (HIV1.25) or more
A8C□			
A5E□			
01E□			
02E□	AWG14 (HIV2.0) or more	AWG14 (HIV2.0) or more	
03E□			

5.2.2 SGMMJ Servomotor Connectors for Standard Environments

(1) Servomotors Main Circuit Without Brakes

(a) Connector Type: JZSP-CFM9-2

Units: mm (in)

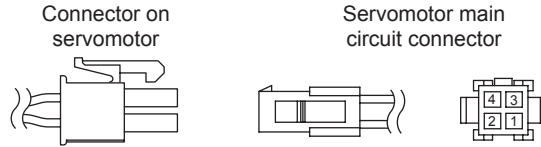

Type		Manufacturer
Cap	5559-04P	Molex Japan Co., Ltd.
Socket	5558TL	

(b) Connector Pin Arrangement

Pin No.	Signal	Lead Color
1	Phase U	Red
2	Phase V	White
3	Phase W	Blue
4	FG	Green/Yellow

(2) Servomotors With Brakes

(a) Connector Type: JZSP-CFM9-3

Units: mm (in)

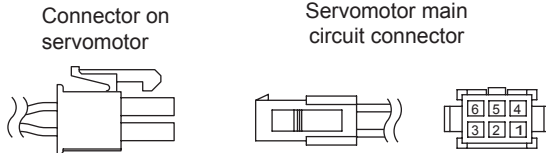

Type		Manufacturer
Cap	5559-06P	Molex Japan Co., Ltd.
Socket	5558TL	

(b) Connector Pin Arrangement

Pin No.	Signal	Lead Color	Remarks
1	Phase U	Red	-
2	Phase V	White	-
3	Phase W	Blue	-
4	FG	Green/Yellow	-
5	Brake terminal	Black	No polarity
6	Brake terminal	Black	

5.2.3 SGMAJ Servomotor Connectors for Standard Environments

5.2.3 SGMAJ Servomotor Connectors for Standard Environments

(1) Servomotors Main Circuit Without Brakes

(a) Connector Type: JZSP-CMM9-1

Units: mm (in)

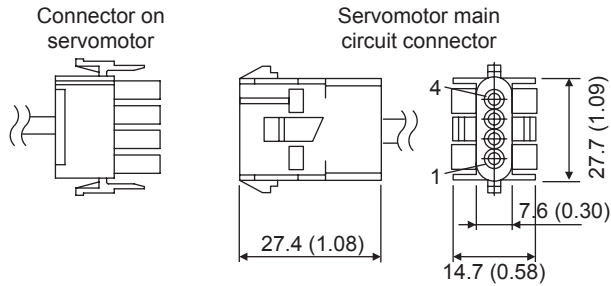

Type		Manufacturer
Cap	350780-1	Tyco Electronics AMP K.K.
Socket	350570-3 or 350689-3	
	Soldered type	

(b) Connector Pin Arrangement

Pin No.	Signal	Lead Color
1	Phase U	Red
2	Phase V	White
3	Phase W	Blue
4	FG	Green/Yellow

(2) Servomotors With Brakes

(a) Connector Type: JZSP-CMM9-2

Units: mm (in)

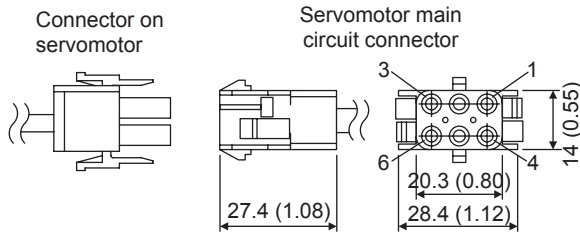

Type		Manufacturer
Cap	350781-1	Tyco Electronics AMP K.K.
Socket	350570-3 or 350689-3	
	Soldered type	

(b) Connector Pin Arrangement

Pin No.	Signal	Lead Color	Remarks
1	Phase U	Red	—
2	Phase V	White	—
3	Phase W	Blue	—
4	FG	Green/Yellow	—
5	Brake terminal	Black	No polarity
6	Brake terminal	Black	

(3) SERVOPACK Power Supply Input Connector Kit

(a) Type

Type	Attached Connector		Connector Type	Manufacturer
JZSP-CJG9-2	CN7	Control power input connector	721-102/026-000	WAGO Company of Japan Ltd.
	CN9	Main circuit power input connector	721-203/026-000	

(b) Dimensional Drawings and Connector Pin Arrangement

- CN7 (Control power input connector)
Connector with cage: 721-102/026-000 (WAGO Company of Japan Ltd.)

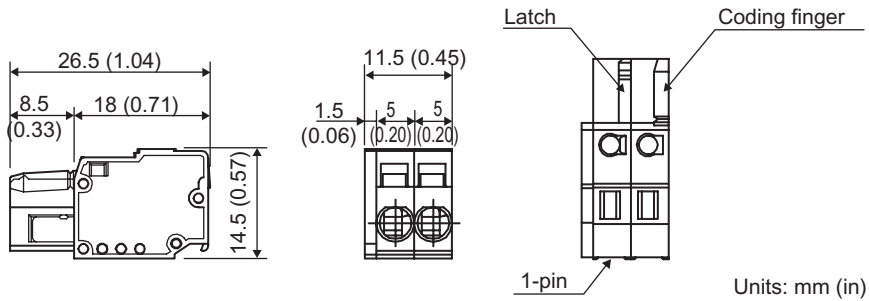

Pin No.	Signal	Terminal Name	Item
1	C1	Control power input (+)	24/48 VDC terminal
2	C2	Control power input (-)	DC ground terminal

- CN9 (Main circuit power input connector)
Connector with cage: 721-203/026-000 (WAGO Company of Japan Ltd.)

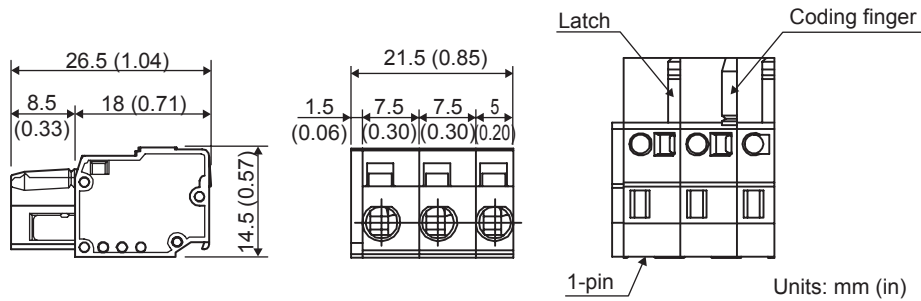

Pin No.	Signal	Terminal Name	Item
1	C1	Control power input (+)	24/48 VDC terminal
2	C2	Control power input (-)	DC ground terminal
3	FG/G	Ground terminal	Motor ground terminal

(4) Connector Kit for SERVOPACK Power Supply Input + Motor Cable Connection

(a) Type

Type	Attached Connector		Connector Type	Manufacturer
JZSP-CJG9-3	CN7	Control power input connector	721-102/026-000	WAGO Company of Japan Ltd.
	CN8	Motor connection connector	721-105/026-000	
	CN9	Main circuit power input connector	721-203/026-000	

(b) Dimensional Drawings and Connector Pin Arrangement

- CN7 (Control power input connector)
Connector with cage: 721-102/026-000 (WAGO Company of Japan Ltd.)

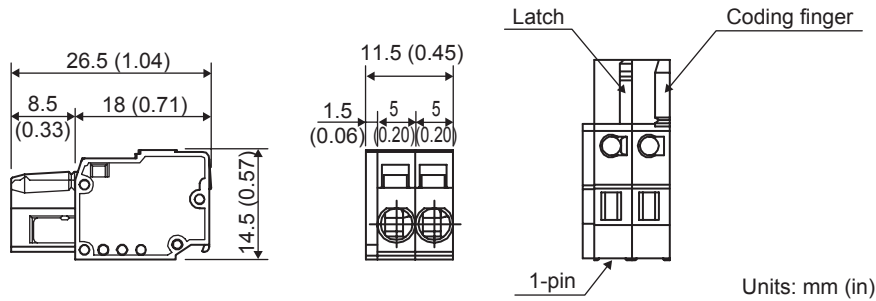

Pin No.	Signal	Terminal Name	Item
1	C1	Control power input (+)	24/48 VDC terminal
2	C2	Control power input (-)	DC ground terminal

- CN8 (Motor connection connector)
Connector with cage: 721-105/026-000 (WAGO Company of Japan Ltd.)

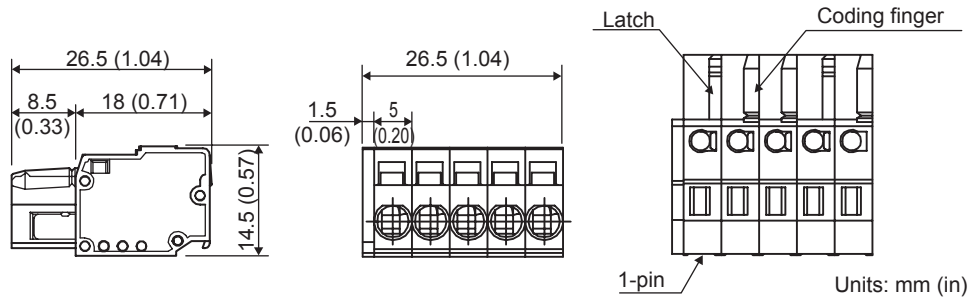

Pin No.	Signal	Terminal Name	Item
1	FG/G	Ground terminal	Motor ground terminal
2	-	Empty	Do not connect.
3	U	Motor phase U connection terminal	Connect the motor U phase.
4	V	Motor phase V connection terminal	Connect the motor V phase.
5	W	Motor phase W connection terminal	Connect the motor W phase.

- CN9 (Main circuit power input connector)
Connector with cage: 721-203/026-000 (WAGO Company of Japan Ltd.)

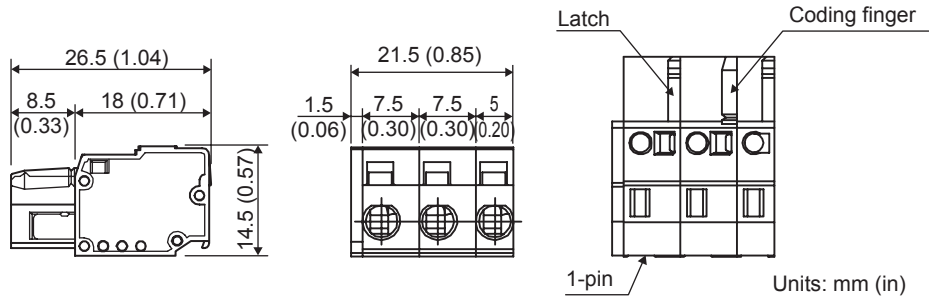

Pin No.	Signal	Terminal Name	Item
1	C1	Control power input (+)	24/48 VDC terminal
2	C2	Control power input (-)	DC ground terminal
3	FG/G	Ground terminal	Ground terminal

5.3.1 Encoder Cable With Connectors

5.3 Encoder Cables for CN4 Connector

When assembling the encoder cable, refer to *5.4 Connectors and Cables for Encoder Signals*.

Contact Yaskawa Controls Co., Ltd. for IP67 applicable cables, flexible cables and connectors.

5.3.1 Encoder Cable With Connectors

Cable Type	Cable Length (L)	Dimensional Drawing
JZSP-CMP00-03	3 m (9.84 ft)	
JZSP-CMP00-05	5 m (16.40 ft)	
JZSP-CMP00-10	10 m (32.81 ft)	
JZSP-CMP00-15	15 m (49.21 ft)	
JZSP-CMP00-20	20 m (65.62 ft)	

5.3.2 Encoder Cable With a SERVOPACK Connector and Encoder Loose Leads

(1) Cable Type

Cable Type	Cable Length (L)	Dimensional Drawing
JZSP-CMP03-03	3 m (9.84 ft)	
JZSP-CMP03-05	5 m (16.40 ft)	
JZSP-CMP03-10	10 m (32.81 ft)	
JZSP-CMP03-15	15 m (49.21 ft)	
JZSP-CMP03-20	20 m (65.62 ft)	

(2) Encoder-end Connector Kit

Type	Manufacturer	Dimensional Drawing
JZSP-CMP9-2	Molex Japan Co., Ltd.	

(3) Encoder Plug Connector Pin Arrangement

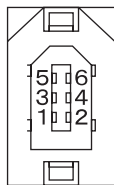

Plug:
JZSP-CMP9-1 (SERVOPACK end)
Socket:
JZSP-CMP9-2 (Encoder end)

16-bit or 17-bit Serial Absolute Encoder Connection Specifications

Pin No.	Signal	Lead Color
1	PG5V	Red
2	PG0V	Black
3	BAT(+)	Orange
4	BAT(-)	White/Orange
5	PS	Light blue
6	/PS	White/Light blue

13-bit Serial Incremental Encoder Connection Specifications

Pin No.	Signal	Lead Color
1	PG5V	Red
2	PG0V	Black
3	-	-
4	-	-
5	PS	Light blue
6	/PS	White/Light blue

5.4 Connectors and Cables for Encoder Signals

The flexible cables are options. Contact your Yaskawa representative.

5.4.1 Connectors and Cables

(1) Cable Type



Cables for Maximum 20 m (65.62 ft)
Wiring Distance

Cable Type	Cable Length
JZSP-CMP09-05	5 m (16.40 ft)
JZSP-CMP09-10	10 m (32.81 ft)
JZSP-CMP09-15	15 m (49.21 ft)
JZSP-CMP09-20	20 m (65.62 ft)

Cables for Maximum 50 m (164.04 ft)
Wiring Distance

Cable Type	Cable Length
JZSP-CMP19-30	30 m (98.43 ft)
JZSP-CMP19-40	40 m (131.23 ft)
JZSP-CMP19-50	50 m (164.04 ft)

(2) SERVOPACK-end Connector for CN2

Units: mm (in)

Model	Manufacturer	Dimensional Drawing
JZSP-CMP9-1	Molex Japan Co., Ltd.	<p>Plug connector (Soldered)</p>

(3) Encoder-end Connector

Units: mm (in)

Model	Manufacturer	Dimensional Drawing
JZSP-CMP9-2	Molex Japan Co., Ltd.	<p>Socket (Soldered)</p>

(4) Encoder Cable Specifications

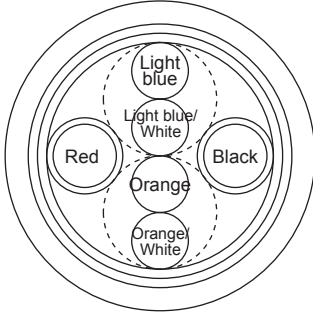
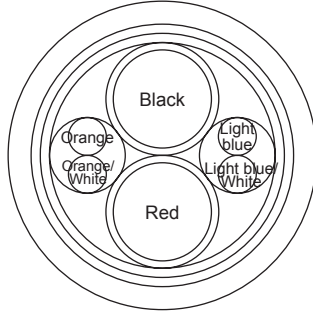
Cable Type	JZSP-CMP09-□□	JZSP-CMP19-□□
Cable Length	20 m (65.62 ft) max.	50 m (164.04 ft) max.
Basic Specifications	T/20276-SB AWG22×2C+AWG24×2P	T/20276-SB AWG16×2C+AWG26×2P
Finished Dimensions	φ6.5 mm (φ0.26 in)	φ6.8 mm (φ0.27 in)
Internal Configuration and Lead Colors		
Yaskawa Standard Specifications (Standard Length)	5 m (16.40 ft), 10 m (32.81 ft), 15 m (49.21 ft), 20 m (65.62 ft)	30 m (98.43 ft), 40 m (131.23 ft), 50 m (164.04 ft)

(5) Encoder Plug Connector Pin Arrangement

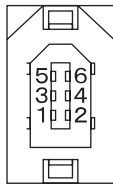

Plug:
JZSP-CMP9-1 (SERVOPACK end)
Socket:
JZSP-CMP9-2 (Encoder end)

16-bit or 17-bit Serial Absolute Encoder Connection Specifications

Pin No.	Signal	Lead Color
1	PG5V	Red
2	PG0V	Black
3	BAT(+)	Orange
4	BAT(-)	White/ Orange
5	PS	Light blue
6	/PS	White/ Light blue

13-bit Serial Incremental Encoder Connection Specifications

Pin No.	Signal	Lead Color
1	PG5V	Red
2	PG0V	Black
3	-	-
4	-	-
5	PS	Light blue
6	/PS	White/ Light blue

5.5 I/O Signal Cables for CN1 Connector

5.5.1 Standard Cables

For the connection diagram, refer to 5.5.3 Connection Diagram.

(1) Cable Types

Cable Type	Cable Length (L)
JZSP-VAI01-1	1 m (3.28 ft)
JZSP-VAI01-2	2 m (6.56 ft)
JZSP-VAI01-3	3 m (9.84 ft)

(2) Dimensional Drawing

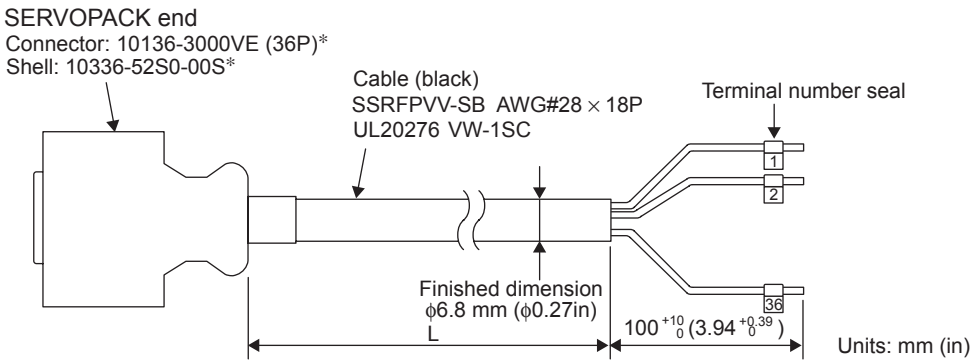

* Manufactured by Sumitomo 3M Ltd.

5.5.2 Connector Type and Cable Size

Use the following connector and wire when assembling the cable. The CN1 connector includes a set of case and a connector.

Connector Type	Case		Connector	
	Type	Qty	Type	Qty
JZSP-VAI09	10336-52A0-008*	1 set	10136-3000VE*	1

* Manufactured by Sumitomo 3M Ltd.

(1) Dimensional Drawing of Case

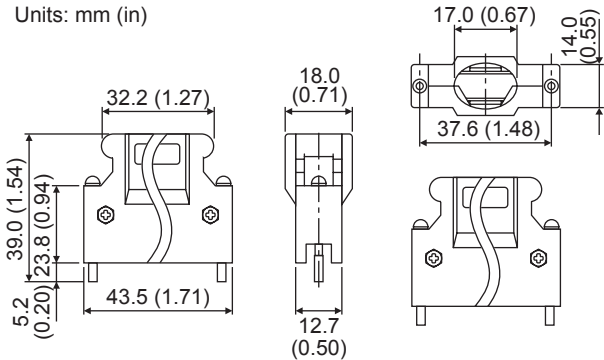

5.5.2 Connector Type and Cable Size

(2) Dimensional Drawing of Connector

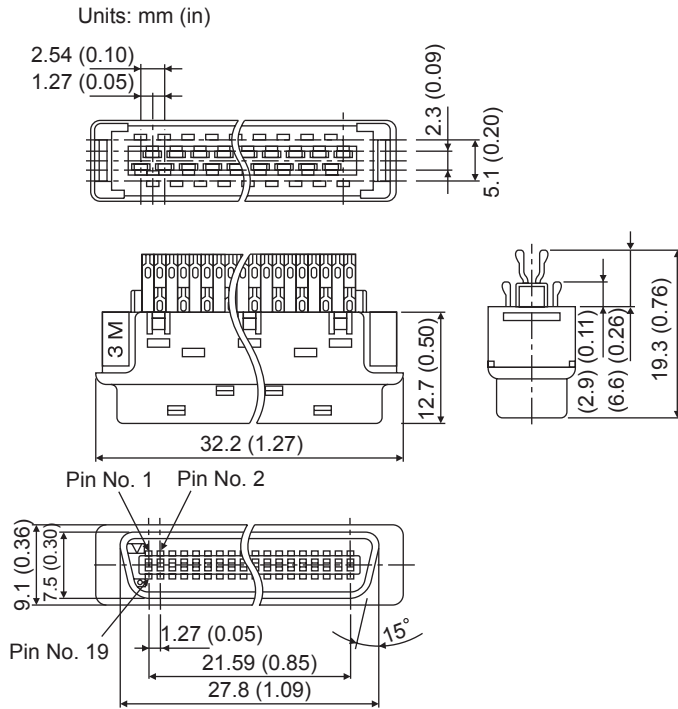

(3) Cable Size

Item	Specifications
Cable	Use twisted-pair or twisted-pair shielded wire.
Applicable Wires	AWG24, 26, 28, 30
Finished Dimension	φ16 mm (φ0.63 in) or less

5.5.3 Connection Diagram

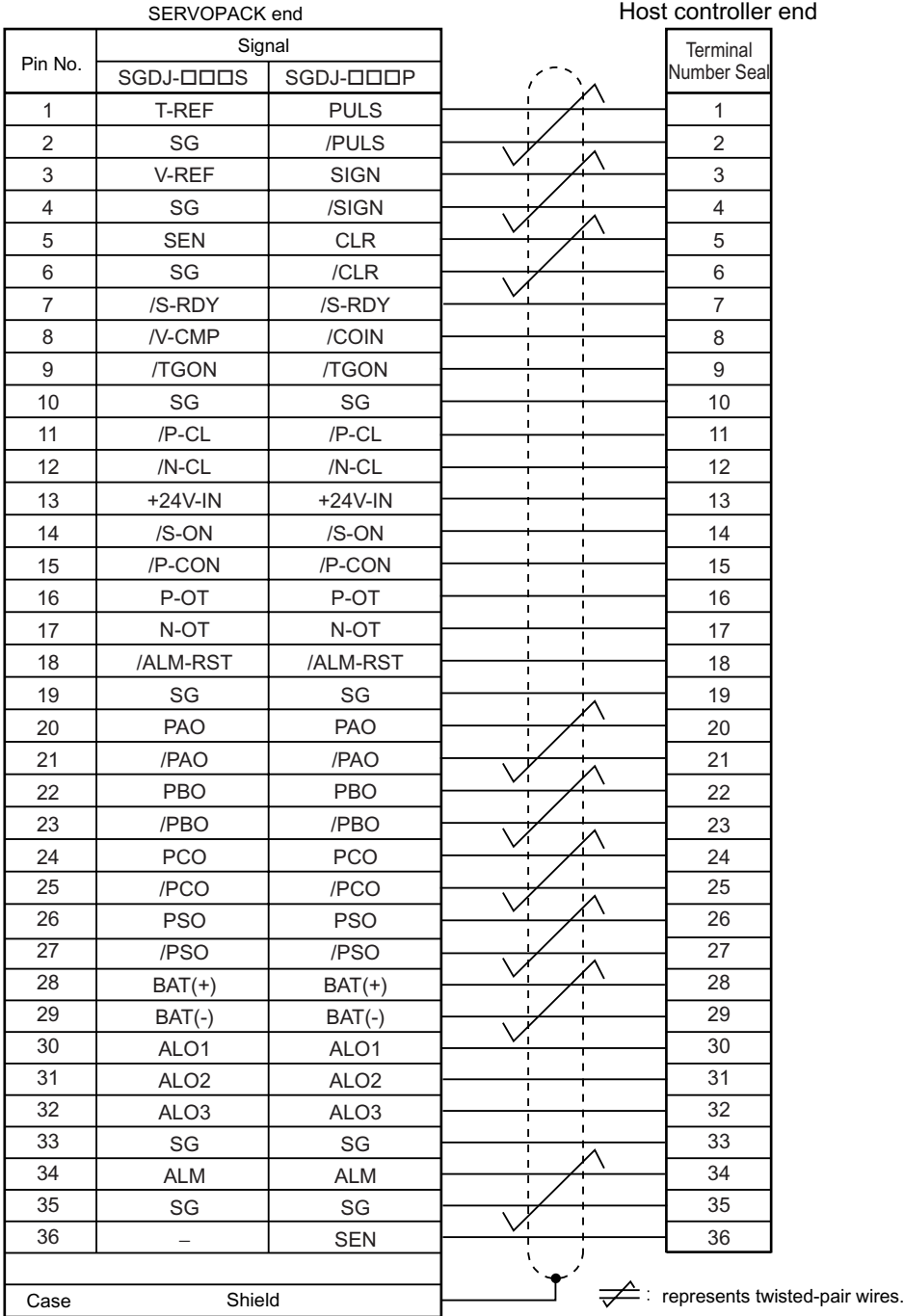

5.6 Peripheral Devices

5.6.1 Cables for Connecting Personal Computers

(1) For 25-pin Connector Cable for NEC PC-98 Series PC

(a) Cable Type: JZSP-CMS01

(b) Dimensional Drawing

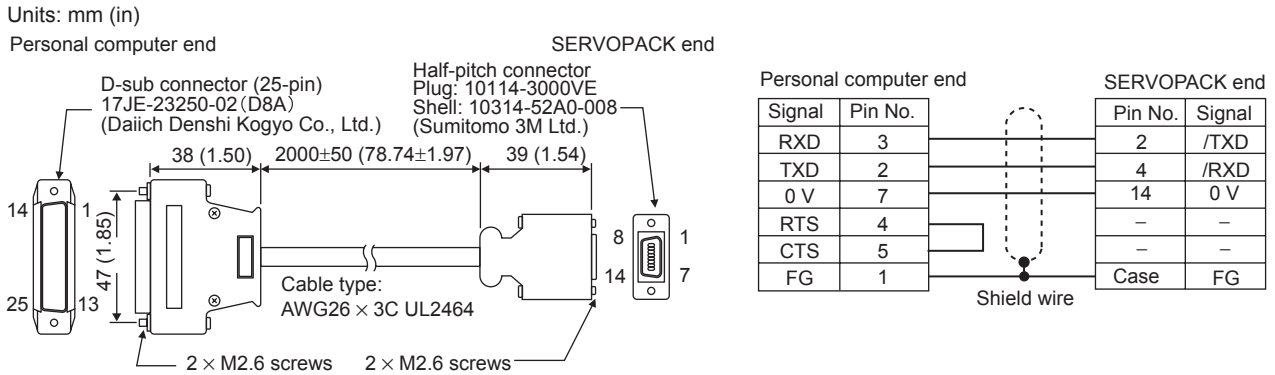

(2) D-sub, 9-pin Connector Cable for IBM PC Compatible

(a) Cable Type: JZSP-CMS02

(b) Dimensional Drawing

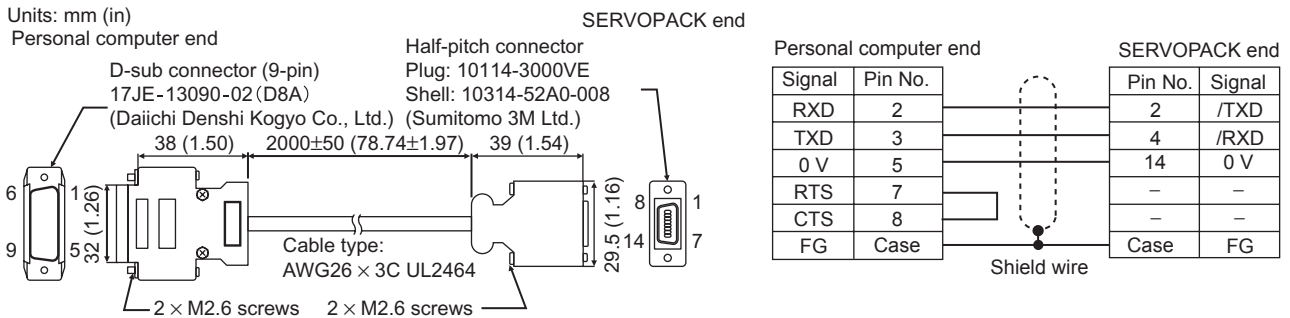

(3) 14-pin Half-pitch Connector Cable for NEC PC-98 Series PC

(a) Cable Type: JZSP-CMS03

(b) Dimensional Drawing

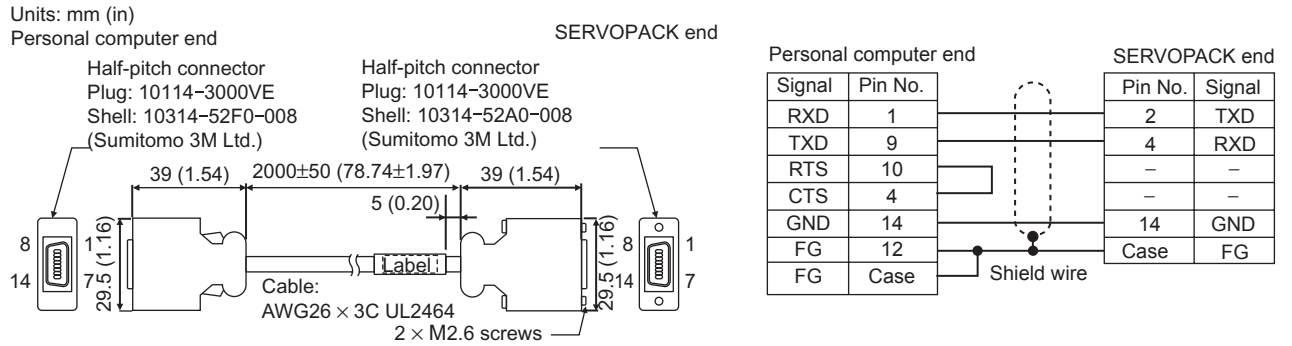

5.6.2 Digital Operator

(1) Model JUSP-OP02A-2 with a 1m (3.28 ft)-connection Cable

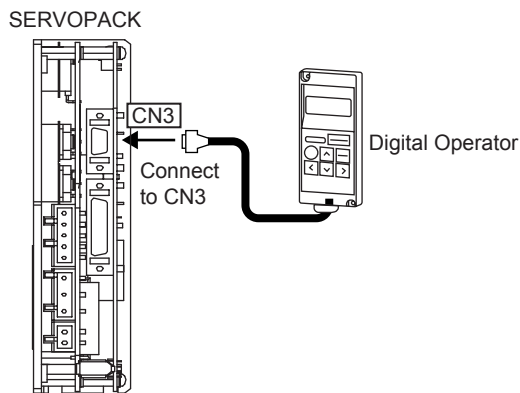

(2) Dimensional Drawing

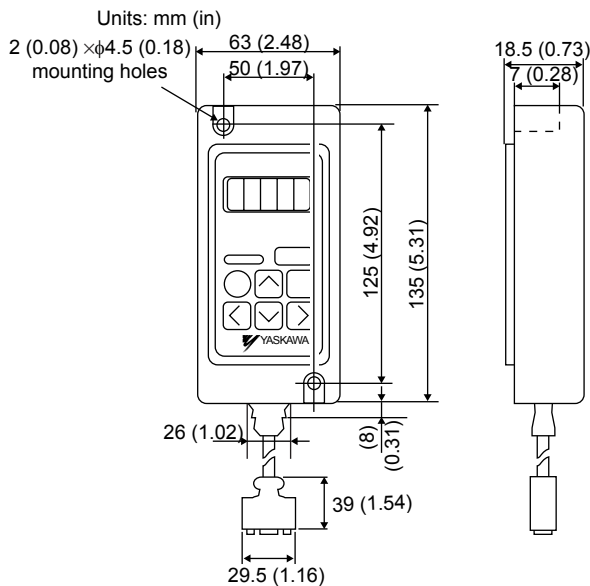

5.6.3 Cables for Analog Monitor

(3) Other Types of the Applicable Connection Cables: JZSP-CMS00-□

The following cables are applicable for longer distance connection.

Units: mm (in)

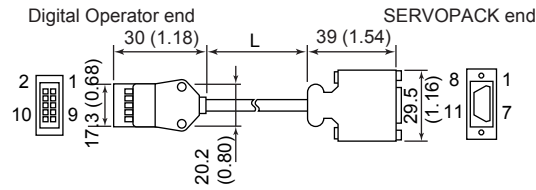

Cable Type	Cable Length (L)
JZSP-CMS00-1	1 m (3.28 ft)
JZSP-CMS00-2	1.5 m (4.92 ft)
JZSP-CMS00-3	2 m (6.56 ft)

5.6.3 Cables for Analog Monitor

(1) Cable Type: JZSP-CA01 (DE9404559)

Connect the specified cables to CN5 connector for monitoring the analog monitor signals. For details, refer to 9.5 Analog Monitor.

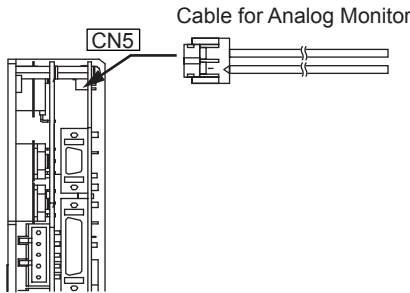

Specify the cable type either JZSP-CA01 or DE9404559 when ordering the cable for analog monitor.

(2) Dimensional Drawing

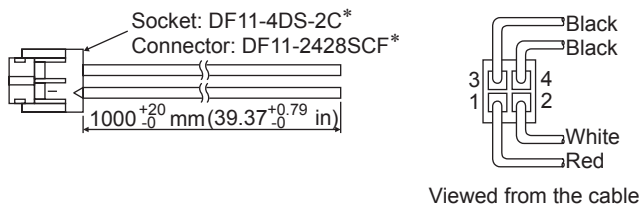

* Manufactured by Hirose Electric Corporation.

(3) Specifications

Pin No.	Cable Color	Signal	Monitoring Item
1	Red	Analog Monitor 2	Motor speed: 1V/1000 min ⁻¹
2	White	Analog Monitor 1	Torque reference: 1V/100% rated torque
3 and 4	Black (2 cables)	GND (0 V)	—

Note: The above monitoring items are the factory settings. The monitoring items can be changed by setting the parameter Pn003. Refer to 9.5 Analog Monitor.

5.6.4 Connector Terminal Block Converter Unit

(1) Model: JUSP-TA36P

The connection between the connector terminal block converter and the SERVOPACK is shown below.

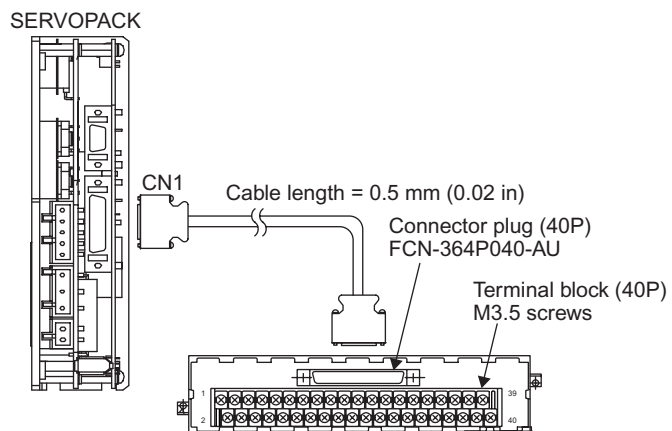

5.6.4 Connector Terminal Block Converter Unit

(2) Connection Diagram

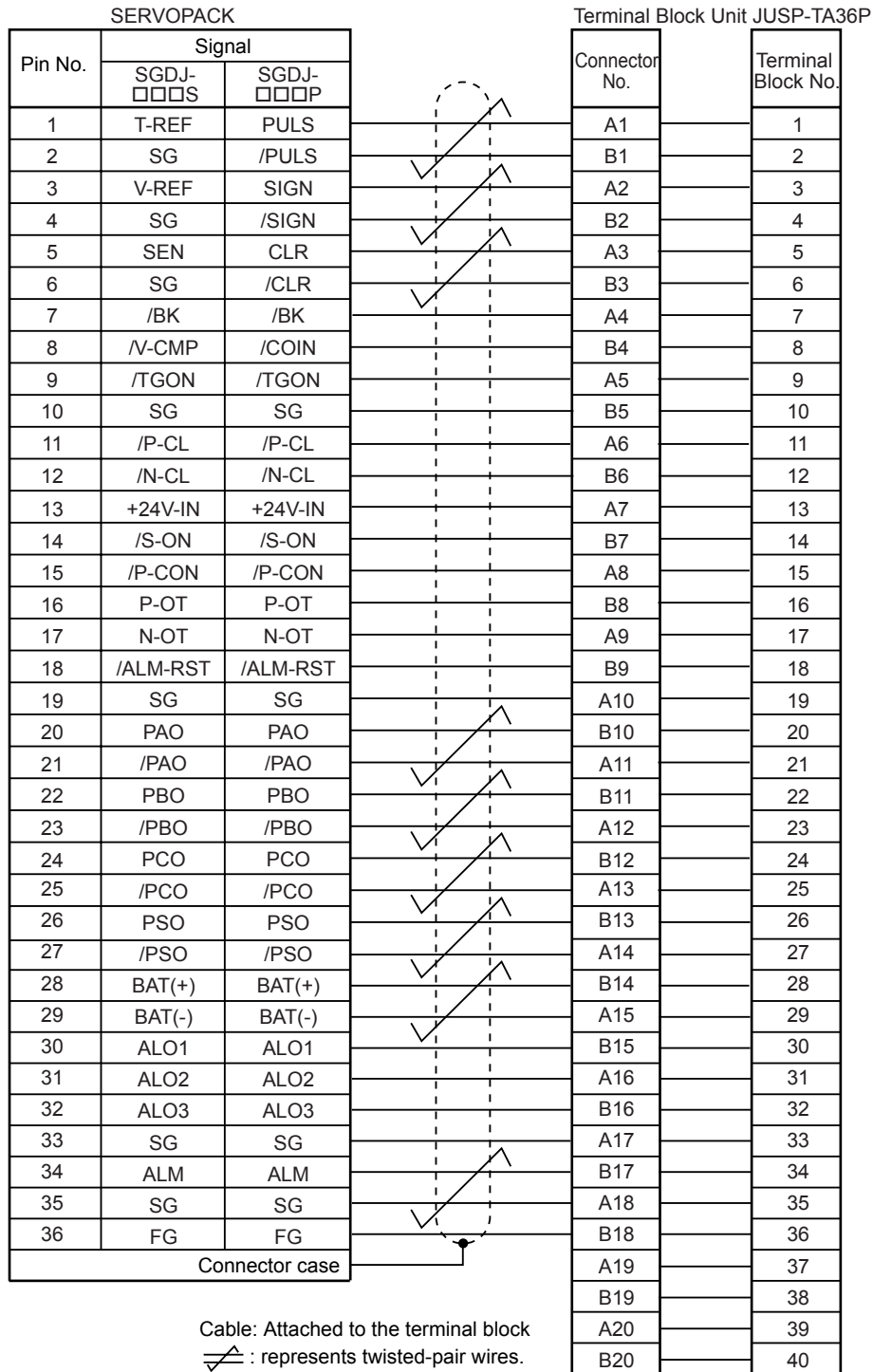

5.6.5 Noise Filter

The noise filters manufactured by Okaya Electric Industries Co., Ltd. are recommended. Contact Yaskawa Controls Co., Ltd.

Select one of the following noise filters according to SERVOPACK capacity. For more details, refer to 2.5.4 *Noise Filters, Surge Suppressors, Magnetic Conductors, and Brake Power Supply*.

Refer to 6.1.3 *Typical Main Circuit Wiring Examples* for the connection method.

5.6.6 Surge Suppressor

(1) Surge Suppressor for Magnetic Contactor

Contact Okaya Electric Industries Co., Ltd.

When using a servomotor with holding brake, install a surge suppressor near the brake coil.

(a) Model: CR50500BL

(b) Specifications

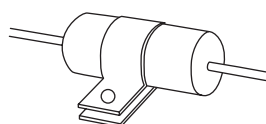

Power supply: 250 VAC
Capacitance: $0.5 \mu\text{F} \pm 20\%$
Resistance: $50 \Omega (1/2 \text{ W}) \pm 30\%$

5.6.7 Variable Resistor for Speed and Torque Setting

(1) Model: 25HP-10B

The multiturn type winding variable resistors with dial MD10-30B4 are manufactured by Sakae Tsushin Kogyo Co., Ltd. Contact Yaskawa Controls Co., Ltd.

(2) Dimensional Drawings

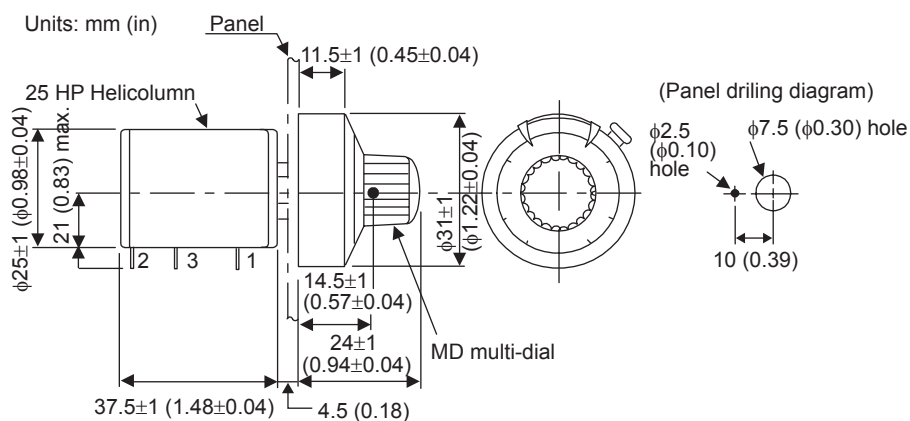

(3) Example of Connection to an External Power Supply

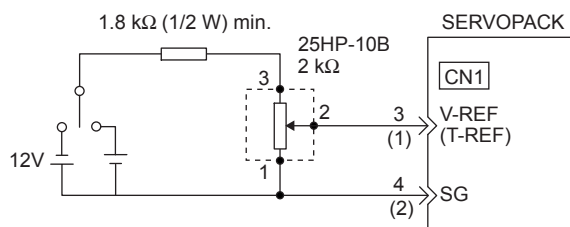

5.6.8 Encoder Signal Converter Unit

5.6.8 Encoder Signal Converter Unit

The encoder signal converter unit (the trade name “Receiver Unit”) converts encoder signal output from the line driver to open-collector or voltage-pulse output.

A socket model 11PFA is required to use a Receiver Unit.

(1) Model: LRX-01 / A□

Contact Yaskawa Controls Co., Ltd.

(2) Specifications

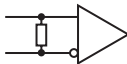
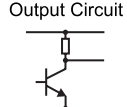
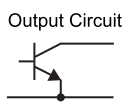
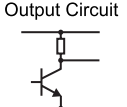
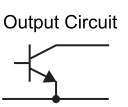
Specifications	Receiver Unit			
	LRX-01/A1	LRX-01/A2	LRX-01/A3	LRX-01/A4
Power Supply	12 VDC ±10 %, 100 mA		5 VDC ±5 %, 100 mA	
Input Signals	Balanced line driver input (RS-422) Input Circuit 			
Output Signals	Voltage pulse output Output Circuit 	Open collector output Output Circuit 	Voltage pulse output Output Circuit 	Open collector output Output Circuit 
Input Signal Level	Differential voltage ≥ 0.3 V, built-in terminator 100 Ω			
Output Signal Level	H: 10 V min. (1 mA) L: 0.5 V max. (30 mA)	L: 0.5 V max. (30 mA) Withstand voltage: 50 V	H: 3 V min. (1 mA) L: 0.5 V max. (30 mA)	L: 0.5 V max. (30 mA) Withstand voltage: 50 V
Ambient Temperature	0 (32 °F) to + 60 °C (140 °F)			
IC Used	Receiver IC: AM26LS32C or the equivalent			
Response Frequency	100 kHz			

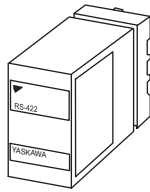

(3) Dimensional Drawings

The socket is optional.

Units: mm (in)

Receiver unit and socket

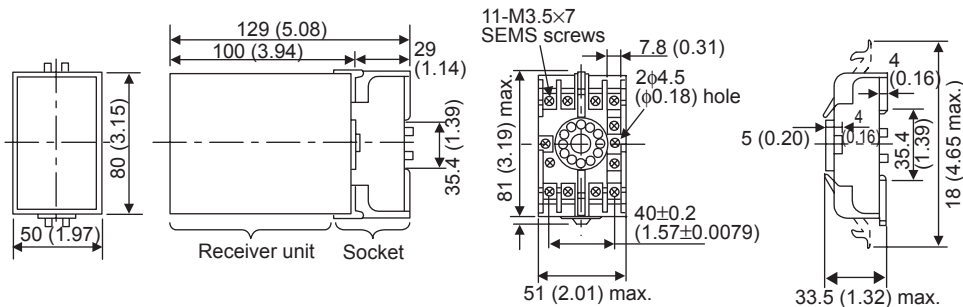

6

Wiring

6.1	Wiring Main Circuit	6-2
6.1.1	Names and Functions of Main Circuit Terminals	6-2
6.1.2	Wiring Main Circuit Power Supply Connector	6-3
6.1.3	Typical Main Circuit Wiring Examples	6-4
6.2	Wiring Encoders	6-5
6.2.1	Connecting an Encoder (CN2) and Output Signals from the SERVOPACK (CN1)	6-5
6.2.2	Encoder Connector (CN2) Terminal Layout	6-6
6.3	Examples of I/O Signal Connections	6-7
6.3.1	SGDJ-□□□S for Speed Control Mode	6-7
6.3.2	SGDJ-□□□P for Position Control Mode	6-8
6.3.3	SGDJ-□□□S for Torque Control Mode	6-9
6.3.4	I/O Signal Connector (CN1) Terminal Layout	6-10
6.3.5	I/O Signal (CN1) Names and Functions	6-12
6.3.6	Interface Circuit	6-14
6.4	Others	6-17
6.4.1	Wiring Precautions	6-17
6.4.2	Wiring for Noise Control	6-18
6.4.3	Installation Conditions of EMC Directives	6-21
6.4.4	Using More Than One SERVOPACK	6-23
6.4.5	Extending Encoder Cables	6-24

6.1 Wiring Main Circuit

This section describes typical examples of main circuit wiring, functions of main circuit terminals, and the power ON sequence.

CAUTION

- Do not bundle or run power and signal lines together in the same duct. Keep power and signal lines separated by at least 300 mm (11.81 in).
Failure to observe this caution may result in malfunction.
- Use twisted-pair shielded wires or multi-core twisted pair shielded wires for signal and encoder (PG) feedback lines.
The maximum length is 3 m (118.11 in) for reference input lines and is 20 m (787.40 in) for PG feedback lines.
- Do not touch the power terminals for five minutes after turning power OFF.
Make sure the charge indicator is turned OFF first before starting an inspection.
- Avoid frequently turning power ON and OFF. Do not turn the power ON or OFF more than once per minute.
Since the SERVOPACK has a capacitor in the power supply, a high charging current flows for 0.2 seconds when the power is turned ON. Frequently turning the power ON and OFF causes main power devices such as capacitors and fuses to deteriorate, resulting in unexpected problems.

6.1.1 Names and Functions of Main Circuit Terminals

Terminal Symbol	Name	Main Circuit Voltage (V)	Maximum Applicable Servomotor Capacity (kW)	Functions
L1, L2	Main circuit power supply input terminal	24	0.05 to 0.08	24 VDC ($\pm 15\%$)
		48	0.05 to 0.3	48 VDC ($\pm 15\%$)
U, V, W	Servomotor connection terminals	–	–	Connects to the servomotor.
C1, C2	Control circuit power supply input terminal	24	0.05 to 0.08	24 VDC ($\pm 15\%$)
		48	0.05 to 0.3	48 VDC ($\pm 15\%$)
	Ground terminals	–	–	Connects to the power supply ground terminals and servomotor ground terminal.

6.1.2 Wiring Main Circuit Power Supply Connector

⚠ CAUTION

- Observe the following precautions when wiring main circuit connector.
 - Remove the connector from the SERVOPACK prior to wiring.
 - Insert only one wire per terminal on the connector.
 - Make sure that the core wire is not electrically shorted to adjacent core wires.

SGDJ SERVOPACK has a removable connector for the main circuit power supply or the control power supply terminal. Use the following procedure when connecting the SERVOPACK to the connector.

(1) Wire Size

Wire can be used simply by stripping back the outer coating. The following is applicable wire sizes.

- Single wire: $\phi 0.5$ ($\phi 0.02$ in) to $\phi 1.6$ ($\phi 0.06$ in) mm
- Braided wire: AWG28 to AWG12

(2) Connection Procedure

1. Strip the end of the wire.

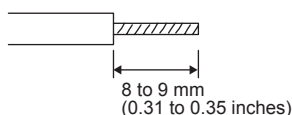

2. Open the wire terminal on the power supply connector housing (plug) with the tool using the procedure shown in Fig. A or B.
 - Insert the connection hook end of the tool into the slot as shown in Fig. A.
 - Use a standard flat-blade screwdriver (blade width of 3.0 to 3.5 mm (0.12 to 0.14 in)) or type 54932-0000 manufactured by Molex Japan Co., Ltd. Put the blade into the slot, as shown in Fig. B, and press down firmly to open the wire terminal.

Either the procedure shown in Fig. A or B can be used to open the wire insert opening.

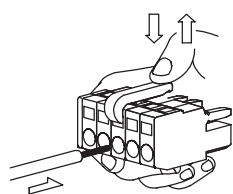

Fig. A

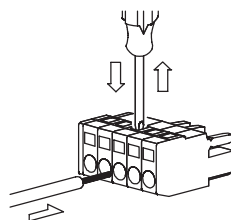
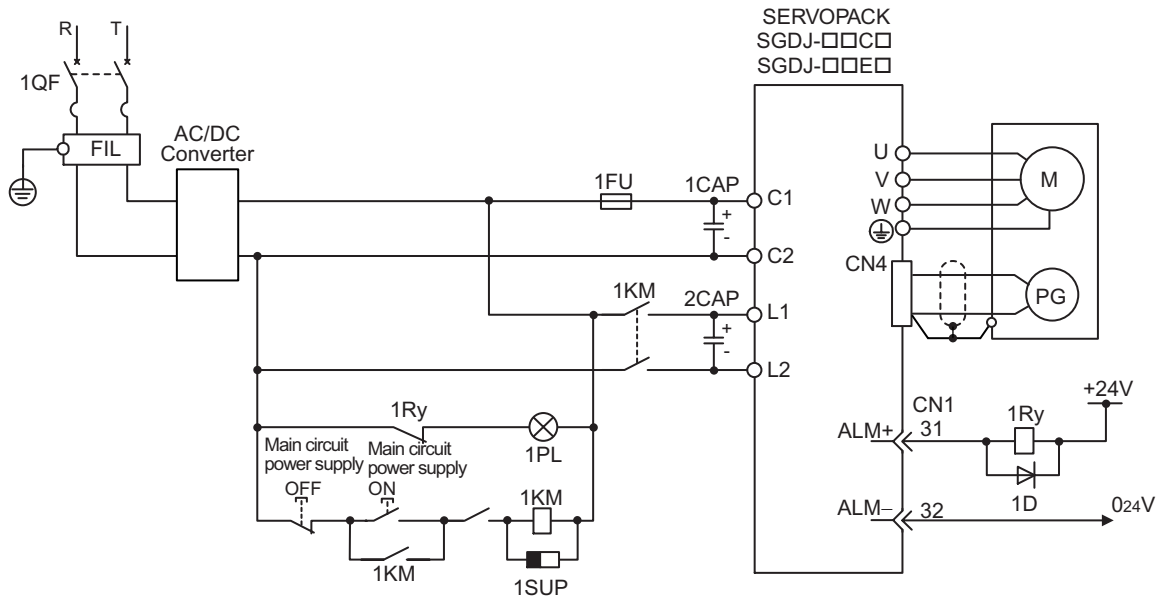

Fig. B

3. Insert the wire core into the opening and then close the opening by releasing the lever connection or removing the screwdriver.

6.1.3 Typical Main Circuit Wiring Examples

Single-phase, 100/200 V



- | | |
|--|-------------------------|
| 1QF : Molded-case circuit breaker | 1Ry : Relay |
| FIL : Noise filter | 1PL : Indicator lamp |
| 1KM : Magnetic contactor | 1SUP : Surge suppressor |
| 1CAP : Capacitor for the control power supply input | 1D : Flywheel diode |
| 2CAP : Capacitor for the main circuit power supply input | 1FU : Fuse |

IMPORTANT

■ Designing a Power ON Sequence

Note the following points when designing the power ON sequence.

- Design the power ON sequence so that main circuit power supply is turned OFF when a servo alarm signal is output. See the previous circuit figure.
- The SERVOPACK will output (1Ry is OFF) a servo alarm signal for two seconds or less when the control power is turned ON. This is required in order to initialize the SERVOPACK.

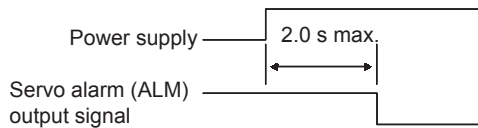

- Select the power supply specifications for the parts in accordance with the input power supply.

6.2 Wiring Encoders

The connection cables between encoder and SERVOPACK and wiring pin numbers differ depending on servo-motor model. Refer to *5 Specifications and Dimensional Drawings of Cables and Peripheral Devices* for details.

6.2.1 Connecting an Encoder (CN2) and Output Signals from the SERVOPACK (CN1)

(1) Incremental Encoders

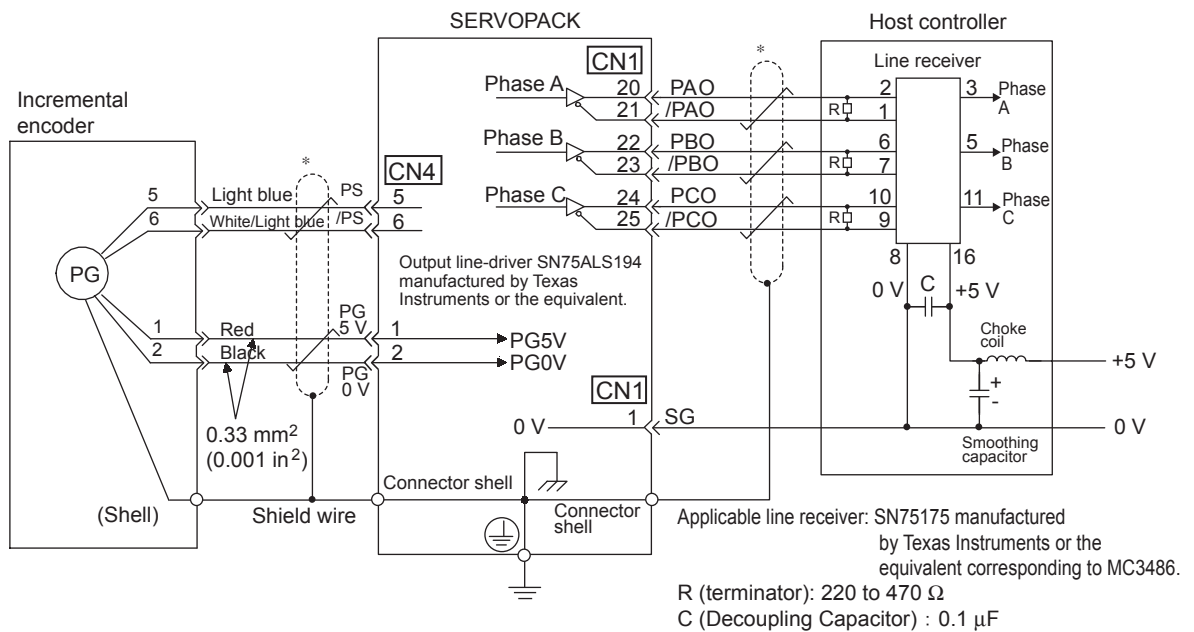

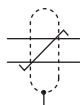
*  : represents twisted-pair wires.

(2) Absolute Encoders

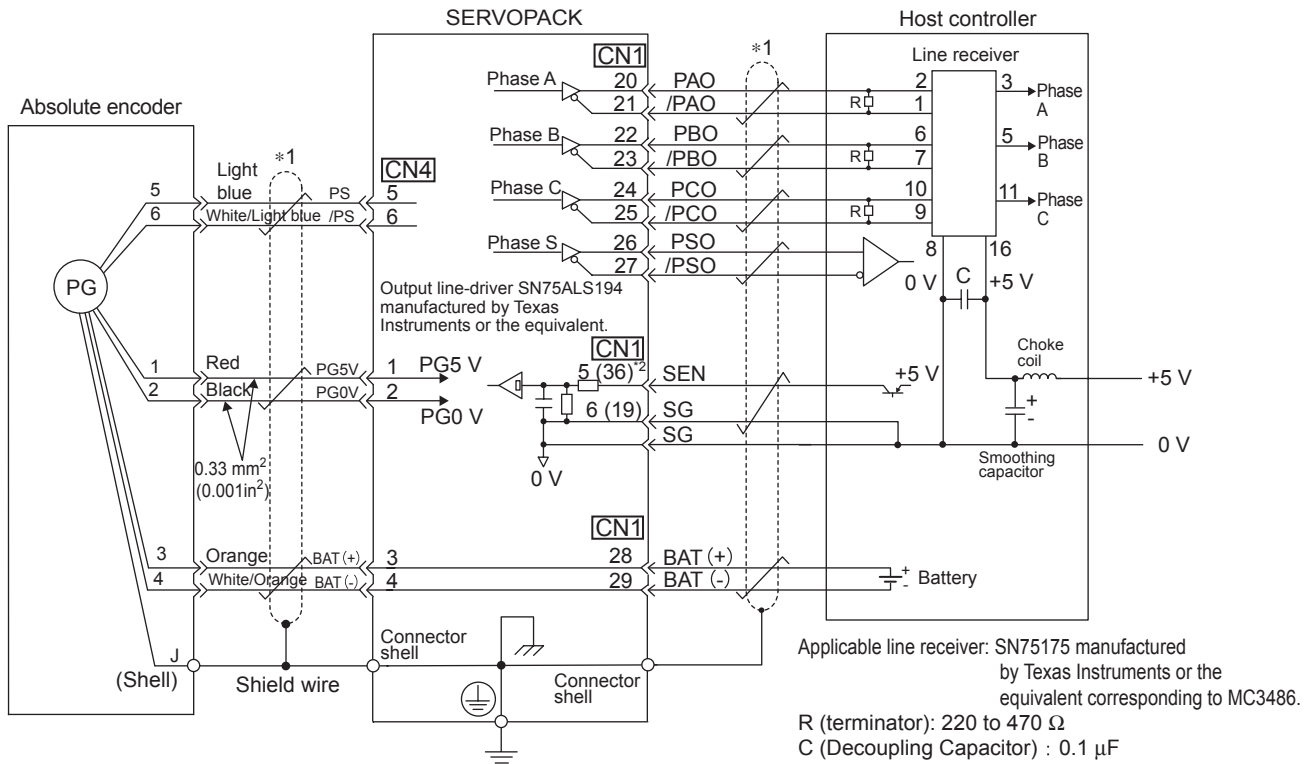

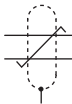
*1  : represents twisted-pair wires.

*2 The pin numbers for the SEN signal differ depending on the SERVOPACK models.
 SGDJ-□□□S: CN1-5
 SGDJ-□□□P: CN1-36

6.2.2 Encoder Connector (CN2) Terminal Layout

1	PG5V	PG power supply +5 V	2	PG 0 V	PG power supply 0 V
3	BAT (+)	Battery (+) (For an absolute encoder)	4	BAT (-)	Battery (-) (For an absolute encoder)
5	PS	PG serial signal input	6	/PS	PG serial signal input
SHELL	Shield	-	-	-	-

6.3 Examples of I/O Signal Connections

6.3.1 SGDJ-□□□S for Speed Control Mode

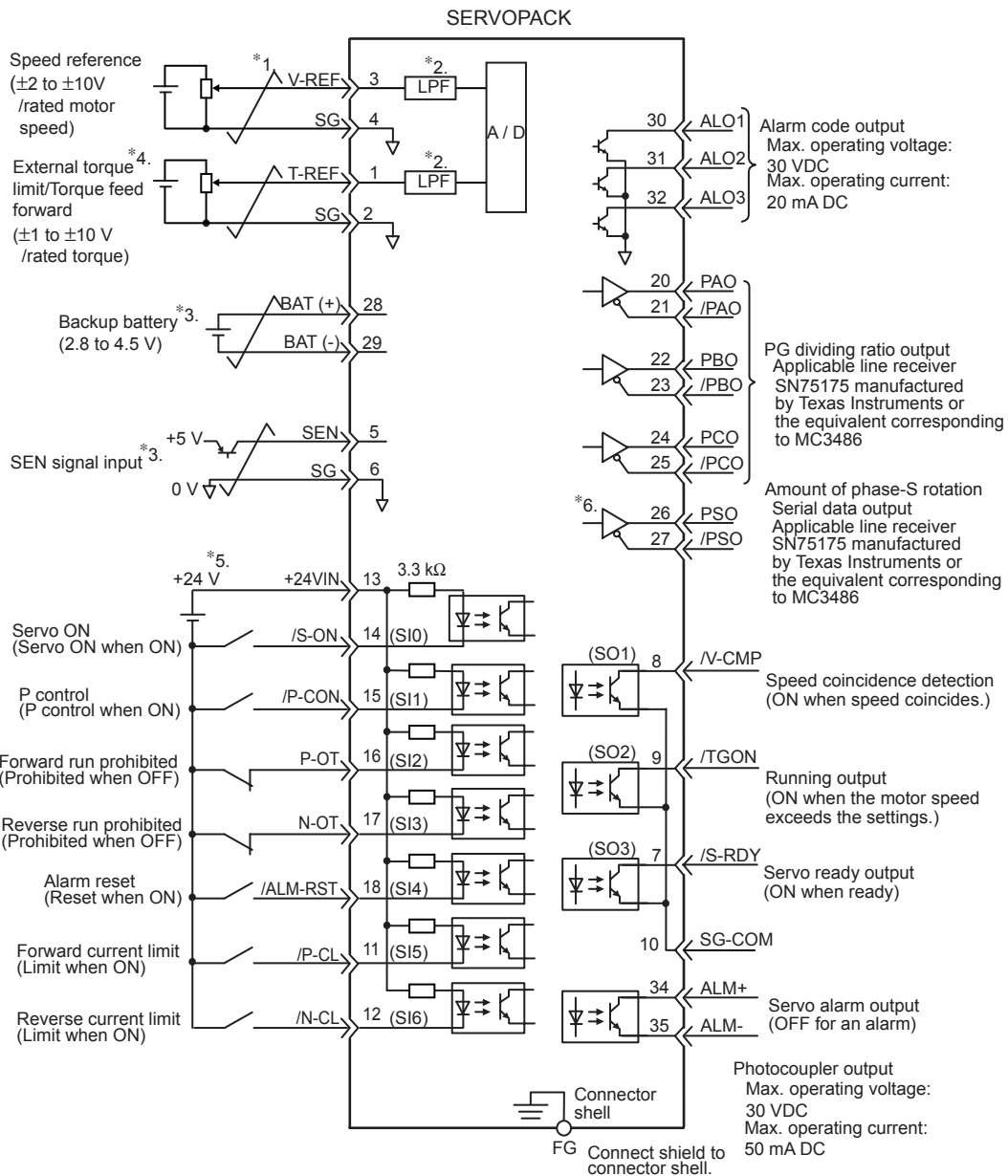

6.3.2 SGDJ-□□□P for Position Control Mode

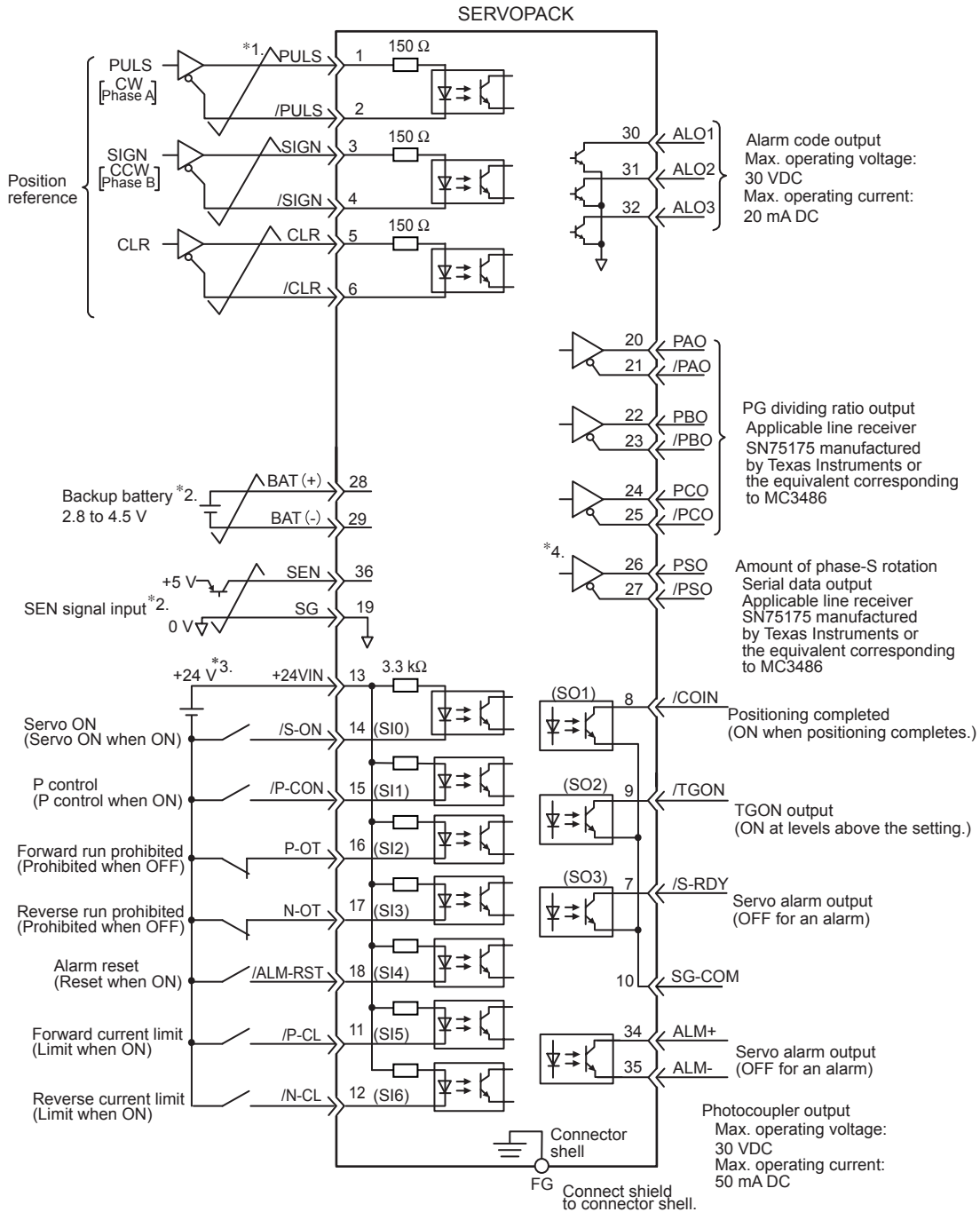

* 1. : represents twisted-pair wires.

* 2. Connect a backup battery when using an absolute encoder. When connecting a battery to the host controller, however, do not connect a backup battery.

* 3. Customers must purchase a 24 VDC power supply with double-shielded enclosure.

* 4. Enabled when using the absolute encoder.

Note: The functions allocated to the input signals SI0 to SI6 and the output signals SO1 to SO3 can be changed by using the parameters. Refer to 7.3.2 *Input Circuit Signal Allocation* and 7.3.3 *Output Circuit Signal Allocation*.

6.3.3 SGDJ-□□□S for Torque Control Mode

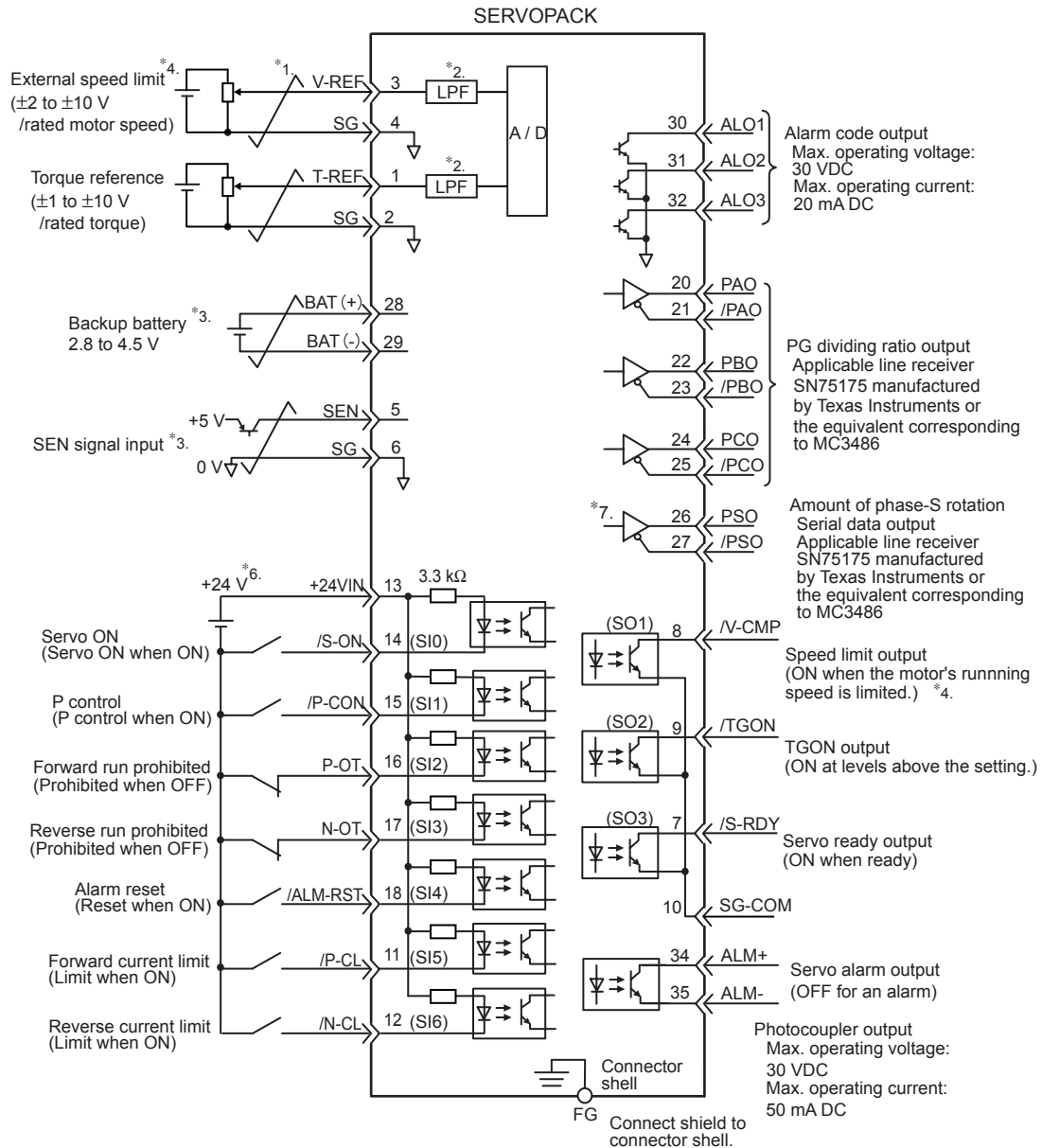

* 1. : represents twisted-pair wires.

* 2. The time constant for the primary filter is 47 μ s.

* 3. Connect a backup battery when using an absolute encoder. When connecting a battery to the host controller, however, do not connect a backup battery.

* 4. Enabled by the parameter setting.

* 5. Customers must purchase a 24 VDC power supply with double-shielded enclosure.

* 6. Enabled when using the absolute encoder.

Note: The functions allocated to the input signals SI0 to SI6 and the output signals SO1 to SO3 can be changed by using the parameters. Refer to 7.3.2 *Input Circuit Signal Allocation* and 7.3.3 *Output Circuit Signal Allocation*.

6.3.4 I/O Signal Connector (CN1) Terminal Layout

(1) SGDJ-□□□S for Speed/Torque Control

The following diagram shows the terminal layout and the signals that are preset before shipping.

Pin Number	Signal Name	Function
1	T-REF	Torque reference input
2	SG	Signal ground for torque reference
3	V-REF	Speed reference input
4	SG	Signal ground for speed reference input
5	SEN	SEN signal for absolute encoder
6	SG-SEN	Signal ground for SEN signal
7	S-RDY	Servo ready signal output
8	/V-CMP	Speed coincidence output
9	/TGON	TGON signal output
10	SG-COM	Signal ground-common
11	/P-CL	Forward current limit ON input
12	/N-CL	Reverse current limit ON input
13	+24VIN	External power supply input
14	/S-ON	Servo ON input
15	/P-CON	P control input
16	P-OT	Forward rotation prohibited
17	N-OT	Reverse rotation prohibited
18	/ALM-RST	Alarm reset input
19	SG-PG	Signal ground for PG output signal
20	PAO	PG dividing pulse output phase A
21	/PAO	PG dividing pulse output phase A
22	PBO	PG dividing pulse output phase B
23	/PBO	PG dividing pulse output phase B
24	PCO	PG dividing pulse output phase C
25	/PCO	PG dividing pulse output phase C
26	PSO	Absolute encoder output phase S
27	/PSO	Absolute encoder output phase S
28	BAT	Backup battery input (+)
29	BAT0	Backup battery input 0 V
30	ALO1	Alarm code output 1
31	ALO2	Alarm code output 2
32	ALO3	Alarm code output 3
33	AL-SG	Alarm code signal ground
34	ALM	Servo alarm output
35	ALM-SG	Alarm output signal ground
36	–	Not used

- Note:
- Do not use unused terminals for relays.
 - Connect the shield of the I/O signal cable to the connector shell.
Connect to the FG (frame ground) at the SERVOPACK-end connector.
 - The functions allocated to the following input and output signals can be changed by using the parameters. Refer to 7.3.2 *Input Circuit Signal Allocation* and 7.3.3 *Output Circuit Signal Allocation*.
 - Input signals: /S-ON, /P-CON, P-OT, N-OT, /ALM-RST, /P-CL, and /N-CL
 - Output signals: /TGON, /S-RDY, and /V-CMP (/COIN)
 - The above output signals can be changed to /CLT, /VLT, /BK, /WARN, and /NEAR.

(2) SGDJ-□□□P for Position Control

Pin Number	Signal Name	Function
1	PULS	Reference pulse input
2	PULS	Reference pulse input
3	SIGN	Reference sign input
4	/SIGN	Reference sign input
5	CLR	Error counter clear input
6	/CLR	Error counter clear input
7	S-RDY	Servo ready signal output
8	/COIN	Positioning complete signal output
9	/TGON	TGON signal output
10	SG-COM	Signal ground-common
11	/P-CL	Forward current limit ON input
12	/N-CL	Reverse current limit ON input
13	+24VIN	External power supply input
14	/S-ON	Servo ON input
15	/P-CON	P control input
16	P-OT	Forward rotation prohibited input
17	N-OT	Reverse rotation prohibited input
18	/ALM-RST	Alarm reset input
19	SG-PG	Signal ground for PG output signal
20	PAO	PG dividing pulse output phase A
21	/PAO	PG dividing pulse output phase A
22	PBO	PG dividing pulse output phase B
23	/PBO	PG dividing pulse output phase B
24	PCO	PG dividing pulse output phase C
25	/PCO	PG dividing pulse output phase C
26	PSO	Absolute encoder output phase S
27	/PSO	Absolute encoder output phase S
28	BAT	Backup battery input (+)
29	BAT0	Backup battery input 0 V
30	ALO1	Alarm code output 1
31	ALO2	Alarm code output 2
32	ALO3	Alarm code output 3
33	AL-SG	Alarm code signal ground
34	ALM	Servo alarm output
35	ALM-SG	Alarm output signal ground
36	SEN	SEN signal for absolute encoder

- Note: 1. Do not use unused terminals for relays.
 2. Connect the shield of the I/O signal cable to the connector shell.
 Connect to the FG (frame ground) at the SERVOPACK-end connector.
 3. The functions allocated to the following input and output signals can be changed by using the parameters. Refer to 7.3.2 *Input Circuit Signal Allocation* and 7.3.3 *Output Circuit Signal Allocation*.
- Input signals: /S-ON, /P-CON, P-OT, N-OT, /ALM-RST, /P-CL, and /N-CL
 - Output signals: /TGON, /S-RDY, and /V-CMP (/COIN)
 - The above output signals can be changed to /CLT, /VLT, /BK, /WARN, and /NEAR.

6.3.5 I/O Signal (CN1) Names and Functions

(1) Input Signals

Signal Name		SGDJ-		Function	Reference		
		□□□S	□□□P				
Common	/S-ON	14	14	Servo ON: Turns ON the servomotor when the gate block in the inverter is released.	8.3.1		
	/P-CON	15	15	Function selected by parameter.		–	
				Proportional control reference	Switches the speed control loop from PI (proportional/integral) to P (proportional) control when ON.	9.4.3	
				Direction reference	With the internal set speed selected: Switch the rotation direction.	8.8.2	
				Control mode switching	Position ↔ speed Position ↔ torque Torque ↔ speed	Enables control mode switching.	8.10.1 8.10.2
				Zero-clamp reference	Speed control with zero-clamp function: Reference speed is zero when ON.		8.5.6
				Reference pulse block	Position control with reference pulse stop: Stops reference pulse input when ON.		8.6.7
	P-OT	16	16	Forward run prohibited Reverse run prohibited	Overtravel prohibited: Stops servomotor when movable part travels beyond the allowable range of motion.	8.3.3	
	N-OT	17	17				
	/P-CL /N-CL	11 12	11 12	Function selected by parameter.		–	
				Forward external torque limit ON Reverse external torque limit ON	Current limit function enabled when ON.	8.9.2	
				Internal speed switching	With the internal set speed selected: Switches the internal speed settings.	8.8	
	/ALM-RST	18	18	Alarm reset: Releases the servo alarm state.		8.11.1	
	+24VIN	13	13	Control power supply input for sequence signals: Users must provide the +24 V power supply. Allowable voltage fluctuation range: 11 to 25 V		6.3.6	
	SEN	5 (6)	36 (19)	Initial data request signal when using an absolute encoder.		8.4.1	
BAT (+)	28	28	Connecting pin for the absolute encoder backup battery.		8.4.1		
BAT (-)	29	29	Do not connect when a battery is connected to the host controller.		6.2		
Speed	V-REF	3 (4)	–	Speed reference speed input: ±2 to ±10 V/rated motor speed (Input gain can be modified using a parameter.)	8.5.2		
Torque	T-REF	1 (2)	–	Torque reference input: ±1 to ±10 V/rated motor torque (Input gain can be modified using a parameter.)	8.7.2		
Position	PULS /PULS SIGN /SIGN	– – – –	1 2 3 4	Reference pulse input for only line driver	Input mode is set from the following pulses. <ul style="list-style-type: none"> • Sign + pulse string • CCW/CW pulse • Two-phase pulse (90° phase differential) 	8.6.1	
	CLR /CLR	– –	5 6	Positional error pulse clear input: Clears the positional error pulse during position control.		8.6.1	

- Note: 1. Pin numbers in parentheses () indicate signal grounds.
 2. The functions allocated to /S-ON, /P-CON, P-OT, N-OT, /ALM-RST, /P-CL, and /N-CL input signals can be changed by using the parameters. Refer to 7.3.2 *Input Circuit Signal Allocation*.
 3. The voltage input range for speed and torque references is a maximum of ± 12 V.

(2) Output Signals

Signal Name		SGDJ-		Function	Reference
		□□□S	□□□P		
Common	ALM+	34	34	Servo alarm: Turns OFF when an error is detected.	8.11.1
	ALM-	35	35		
	/TGON	9 (10)	9 (10)	Detection during servomotor rotation: Detects when the servomotor is rotating at a speed higher than the motor speed setting. Detection speed can be set by using the parameters.	8.11.3
	/S-RDY	7 (10)	7 (10)	Servo ready: ON if there is no servo alarm when the control/main circuit power supply is turned ON.	8.11.4
	PAO	21	21	Phase-A signal Converted two-phase pulse (phases A and B) encoder output signal and zero-point pulse (phase C) signal: RS-422 or the equivalent (Proper line receiver is SN75175 manufactured by Texas Instruments or the equivalent corresponding to MC3486.)	6.2 6.3.1 8.4.6 8.5.7
	/PAO	22	22		
	PBO	23	23		
	/PBO	24	24		
	PCO	25	25		
	/PCO	26	26		
PSO	27	27	Phase-S signal With an absolute encoder: Outputs serial data corresponding to the number of revolutions (RS-422 or the equivalent)	8.11.1	
/PSO	28	28			
ALO1	30	30	Alarm code output: Outputs 3-bit alarm codes. Open-collector: 30 V and 20 mA rating maximum	8.11.1	
ALO2	31	31			
ALO3	32 (33)	32 (33)			
FG	Shell		Connected to frame ground if the shield wire of the I/O signal cable is connected to the connector shell.	—	
Speed	/V-CMP	8 (10)	—	Speed coincidence (output in Speed Control Mode): Detects whether the motor speed is within the setting range and if it matches the reference speed value.	8.5.8
Position	/COIN	—	8 (10)	Positioning completed (output in Position Control Mode): Turns ON when the number of positional error pulses reaches the value set. The setting is the number of positional error pulses set in reference units (input pulse units defined by the electronic gear).	8.6.5
Reserved	/CLT /VLT /BK /WARN /NEAR	—		Reserved terminals The functions allocated to /TGON, /S-RDY, and /V-CMP (/COIN) can be changed by using the parameters.	8.3.4 8.6.6 8.7.4 8.9.5 8.11.2
	—	36	—	Terminals not used Do not connect relays to these terminals.	—

- Note: 1. Pin numbers in parentheses () indicate signal grounds.
 2. The functions allocated to /TGON, /S-RDY, and /V-CMP (/COIN) can be changed by using the parameters. /CLT, /VLT, /BK, /WARN, and /NEAR signals can also be changed. Refer to 7.3.3 *Output Circuit Signal Allocation*.

6.3.6 Interface Circuit

This section shows examples of SERVOPACK I/O signal connection to the host controller.

(1) Interface for Reference Input Circuits

(a) SGDJ-□□□S Analog Input Circuit

CN1 connector terminals, 3-4: Speed reference input and 1-2: Torque reference input are explained below.

Analog signals are either speed or torque reference signals at the impedance below.

- Reference speed input: About 14 kΩ
- Reference torque input: About 14 kΩ

The maximum allowable voltages for input signals is ±12 V.

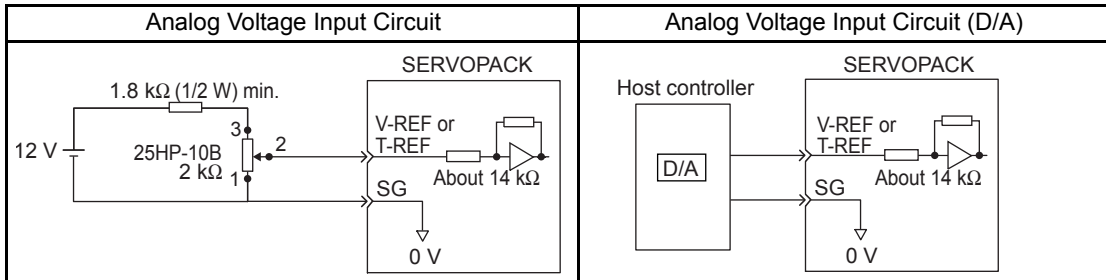

(b) SGDJ-□□□P Position Reference Input Circuit

CN1 connector terminals, 1-2: Reference pulse input, 3-4: Reference code input and 5-6: Clear input are explained below.

An output circuit for the reference pulse and position error pulse clear signal at the host controller can be either line-driver or open-collector outputs. The following shows by type.

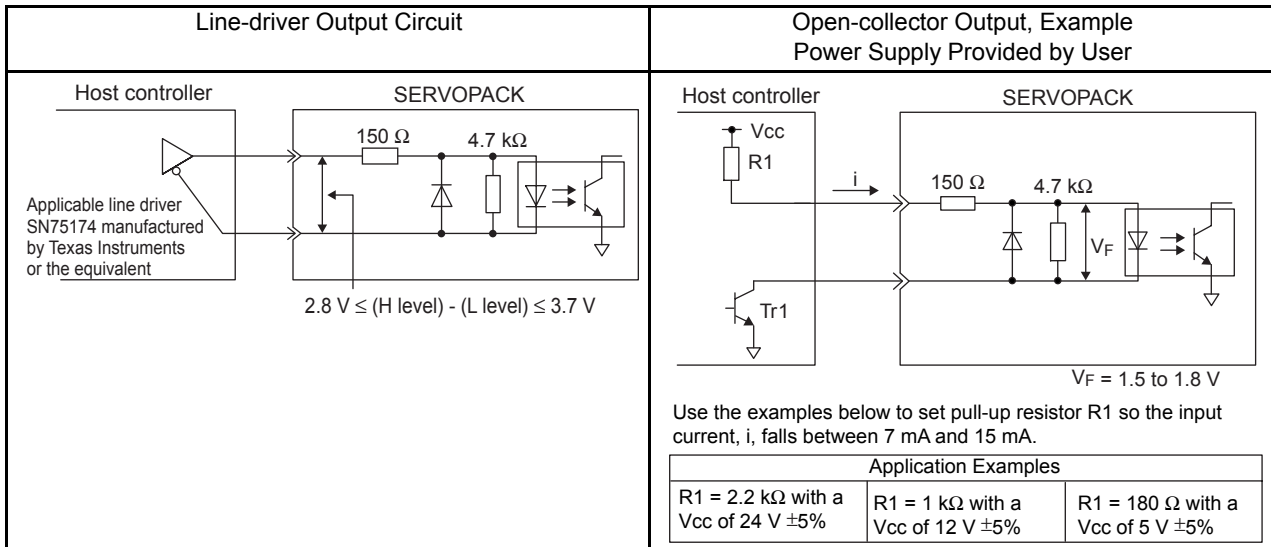

(2) Sequence Input Circuit Interface

CN1 connector terminals 11 to 18 is explained below.

The sequence input circuit interface connects through a relay or open-collector transistor circuit. Select a low-current relay otherwise a faulty contact will result.

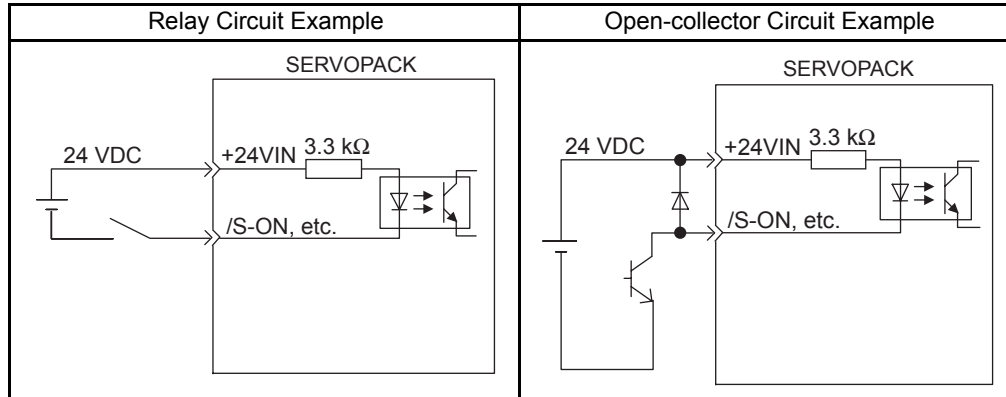

Note: The 24 VDC external power supply capacity must be 50 mA minimum.



For SEN input signal circuit, refer to 8.4 Absolute Encoders.

(3) Sink Circuit and Source Circuit

The SERVOPACK's I/O circuit uses a bidirectional photocoupler. Select either the sink circuit or the source circuit according to the specifications required for each machine.

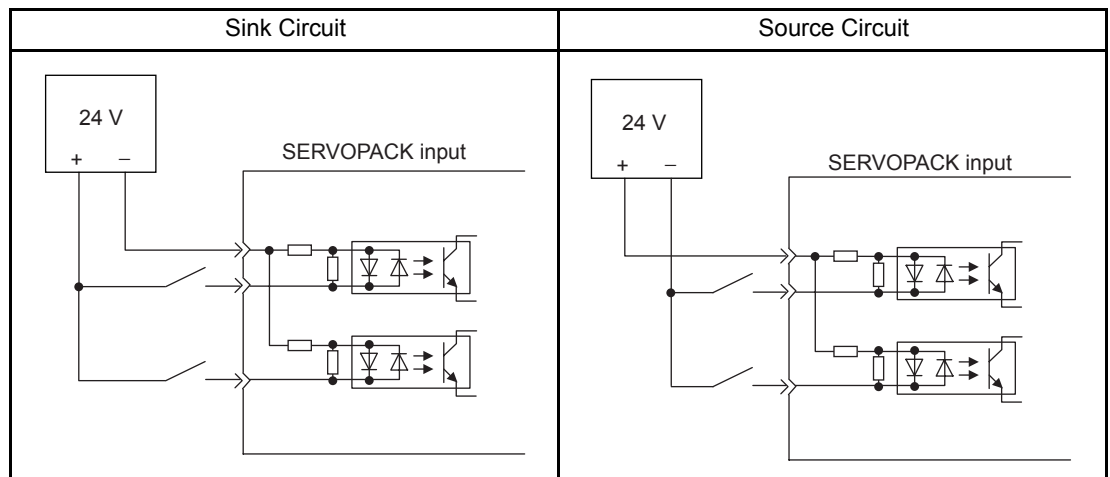

(4) Output Circuit Interface

There are three types of SERVOPACK output circuits:

(a) Line Driver Output Circuit

CN1 connector terminals, 20-21: phase-A signal, 22-23: phase-B signal and 24-25: phase-C signal are explained below.

Encoder serial data converted to two-phase (phases A and B) pulse output signals (PAO, /PAO, PBO, /PBO), zero-point pulse signals (PCO, /PCO), and the amount of phase-S rotation signal (PSO, /PSO) are output via line-driver output circuits. Normally, the SERVOPACK uses this output circuit in speed control to comprise the position control system at the host controller. Connect the line-driver output circuit through a line receiver circuit at the host controller.

(b) Open-collector Output Circuit

CN1 connector terminals 30 to 33: Alarm code output are explained below.

Alarm code signals (ALO1, ALO2, ALO3) are output from open-collector transistor output circuits. Connect an open-collector output circuit through a photocoupler, relay circuit, or line receiver circuit.

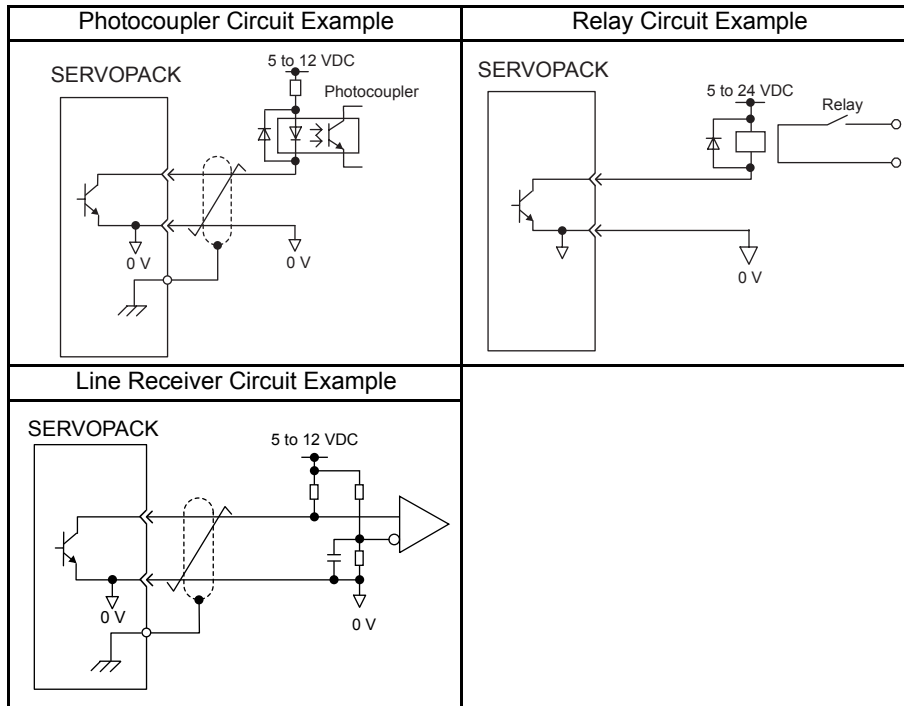

Note: The maximum allowable voltage and current capacities for open-collector output circuits are as follows:

- Voltage: 30 VDC
- Current: 20 mA DC

(c) Photocoupler Output Circuit

Photocoupler output circuits are used for servo alarm (ALM), servo ready (/S-RDY), and other sequence output signal circuits. Connect a photocoupler output circuit through a relay circuit or line receiver circuit.

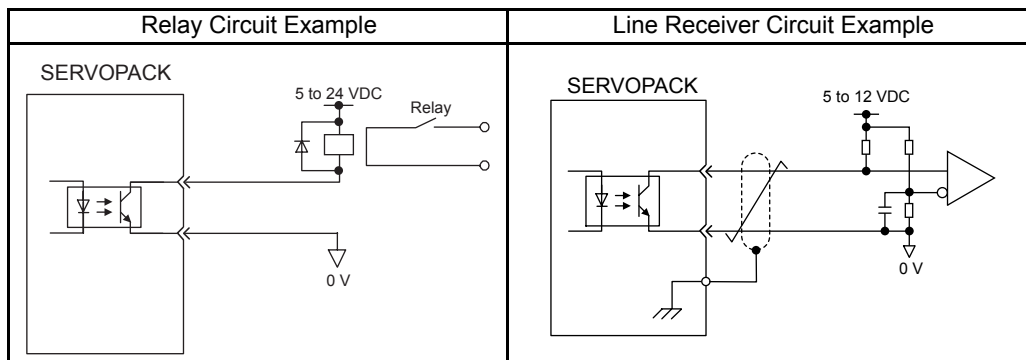

Note: The maximum allowable voltage and current capacities for photocoupler output circuits are as follows:

- Voltage: 30 VDC
- Current: 50 mA DC

6.4 Others

6.4.1 Wiring Precautions

To ensure safe and stable operation, always observe the following wiring precautions.

IMPORTANT

1. For wiring for reference inputs and encoders, use the specified cables. Refer to *5 Specifications and Dimensional Drawings of Cables and Peripheral Devices* for details.
Use cables as short as possible.
2. For a ground wire, use as thick a cable as possible (2.0 mm² (0.003 in²) or thicker).
 - At least class-3 ground (100 Ω max.) is recommended.
 - Ground to one point only.
 - If the servomotor is insulated from the machine, ground the servomotor directly.
3. Do not bend or apply tension to cables.
The conductor of a signal cable is very thin (0.2 to 0.3 mm (0.0079 to 0.012 in)), so handle the cables carefully.
4. Use a noise filter to prevent noise interference.
(For details, refer to *6.4.2 Wiring for Noise Control*.)
 - If the equipment is to be used near private houses or may receive noise interference, install a noise filter on the input side of the power supply line.
 - Because the SERVOPACK is designed as an industrial device, it provides no mechanism to prevent noise interference.
5. To prevent malfunction due to noise, take the following actions:
 - Position the input reference device and noise filter as close to the SERVOPACK as possible.
 - Always install a surge suppressor in the relay, solenoid and magnetic contactor coils.
 - The distance between a power line (such as a power supply line or servomotor cable) and a signal line must be at least 300 mm (11.81 in). Do not put the power and signal lines in the same duct or bundle them together.
 - Do not share the power supply with an electric welder or electrical discharge machine. When the SERVOPACK is placed near a high-frequency generator, install a noise filter on the input side of the power supply line.
6. Use a molded-case circuit breaker (QF) or fuse to protect the power supply line from high voltage.
 - The SERVOPACK connects directly to a commercial power supply without a transformer, so always use a QF or fuse to protect the SERVOPACK from accidental high voltage.
7. The SERVOPACKS do not have built-in ground protection circuits. To configure a safer system, install an earth leakage breaker for protection against overloads and short-circuiting, or install an earth leakage breaker combined with a wiring circuit breaker for ground protection.

6.4.2 Wiring for Noise Control

(1) Wiring Example

The SERVOPACK uses high-speed switching elements in the main circuit. It may receive “switching noise” from these high-speed switching elements if the processing of wiring or grounding around the SERVOPACK is not appropriate. To prevent this, always wire and ground the SERVOPACK correctly.

The SGDH SERVOPACK has a built-in microprocessor (CPU), so protect it from external noise as much as possible by installing a noise filter in the appropriate place.

The following is an example of wiring for noise control.

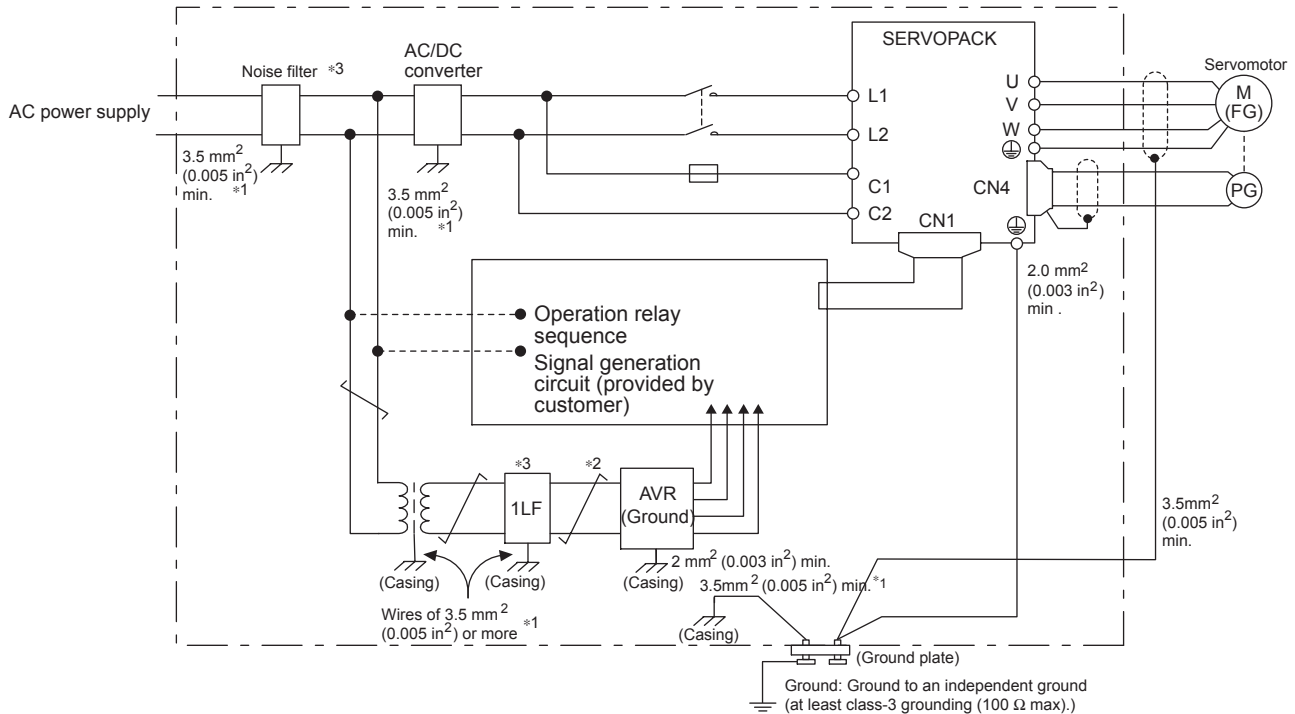

- *1 For ground wires connected to the casing, use a thick wire with a thickness of at least 3.5 mm² (0.005 in²) (preferably, plain stitch cooper wire)
- *2 : represents twisted-pair wires.
- *3 When using a noise filter, follow the precautions in 6.4.2 Wiring for Noise Control (3) Using Noise Filter.

(2) Correct Grounding

(a) Grounding the Motor Frame

Always connect servomotor frame terminal FG to the SERVOPACK ground terminal ⊖. Also be sure to ground the ground terminal ⊖.

If the servomotor is grounded via the machine, a switching noise current will flow from the SERVOPACK power unit through servomotor stray capacitance. The above grounding is required to prevent the adverse effects of switching noise.

(b) Noise on the Reference Input Line

If the reference input line receives noise, ground the 0 V line (SG) of the reference input line. If the main circuit wiring for the motor is accommodated in a metal conduit, ground the conduit and its junction box.

For all grounding, ground at one point only.

(3) Using Noise Filters

Use an inhibit type noise filter to prevent noise from the power supply line. The following table lists recommended noise filters for each SERVOPACK model.

Install a noise filter on the power supply line for peripheral equipment as necessary.

IMPORTANT

■ Recommended noise filter

- Model: SUP-P8HEPR-4
- Manufacturer: Okaya Electric Industries Co., Ltd.

■ Precautions when using noise filter

Always observe the following installation and wiring instructions. Incorrect use of a noise filter halves its benefits.

1. Do not put the input and output lines in the same duct or bundle them together.

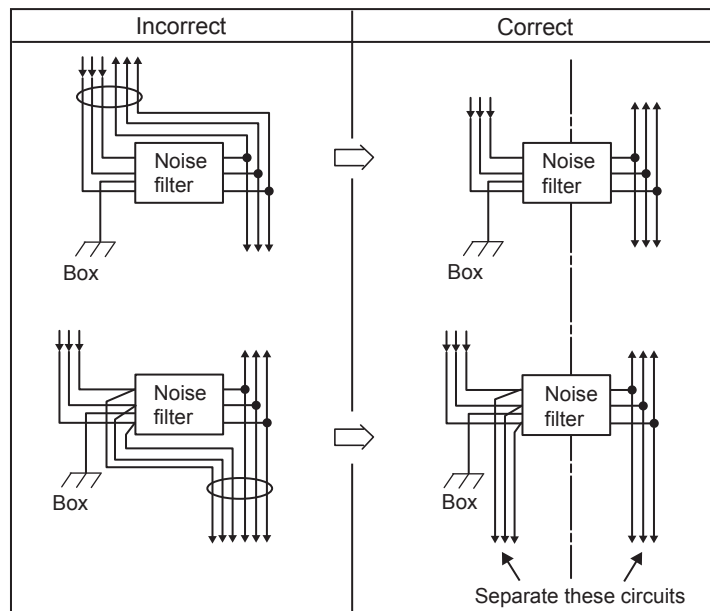

2. Separate the noise filter ground wire from the output lines.

Do not accommodate the noise filter ground wire, output lines, and other signal lines in the same duct or bundle them together.

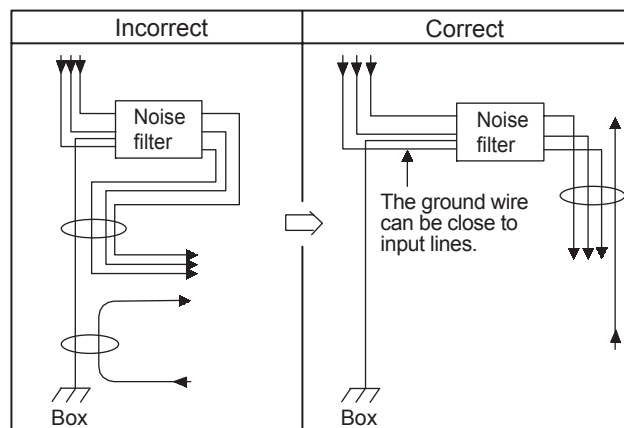

3. Connect the noise filter ground wire directly to the ground plate.
Do not connect the noise filter ground wire to other ground wires.

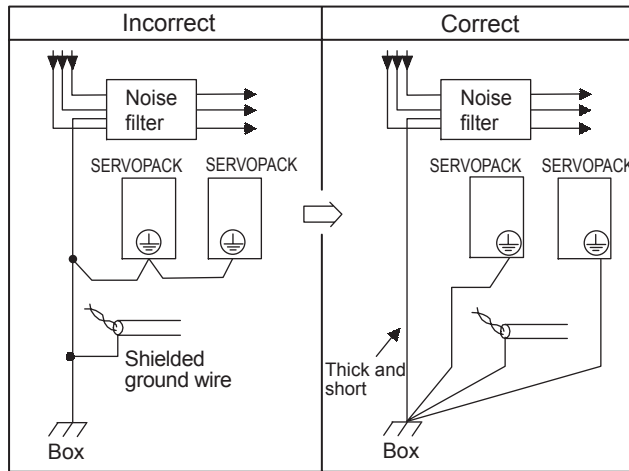

4. When grounding a noise filter inside a unit:
If a noise filter is located inside a unit, connect the noise filter ground wire and the ground wires from other devices inside the unit to the ground plate for the unit first, then ground these wires.

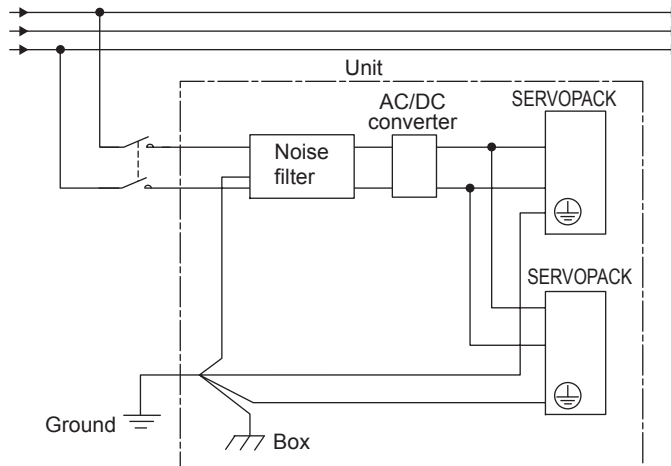

6.4.3 Installation Conditions of EMC Directives

To adapt a combination of a SGMAJ servomotor and a SGDJ SERVOPACK to EMC Directives (EN55011 group1 classA, EN61000-6-2), the following conditions must be satisfied.

(1) EMC Installation Conditions

This section describes the installation conditions that satisfy EMC guidelines for each model of the SGDJ SERVOPACK.

This section describes the EMC installation conditions satisfied in test conditions prepared by Yaskawa. The actual EMC level may differ depending on the actual system's configuration, wiring, and other conditions.

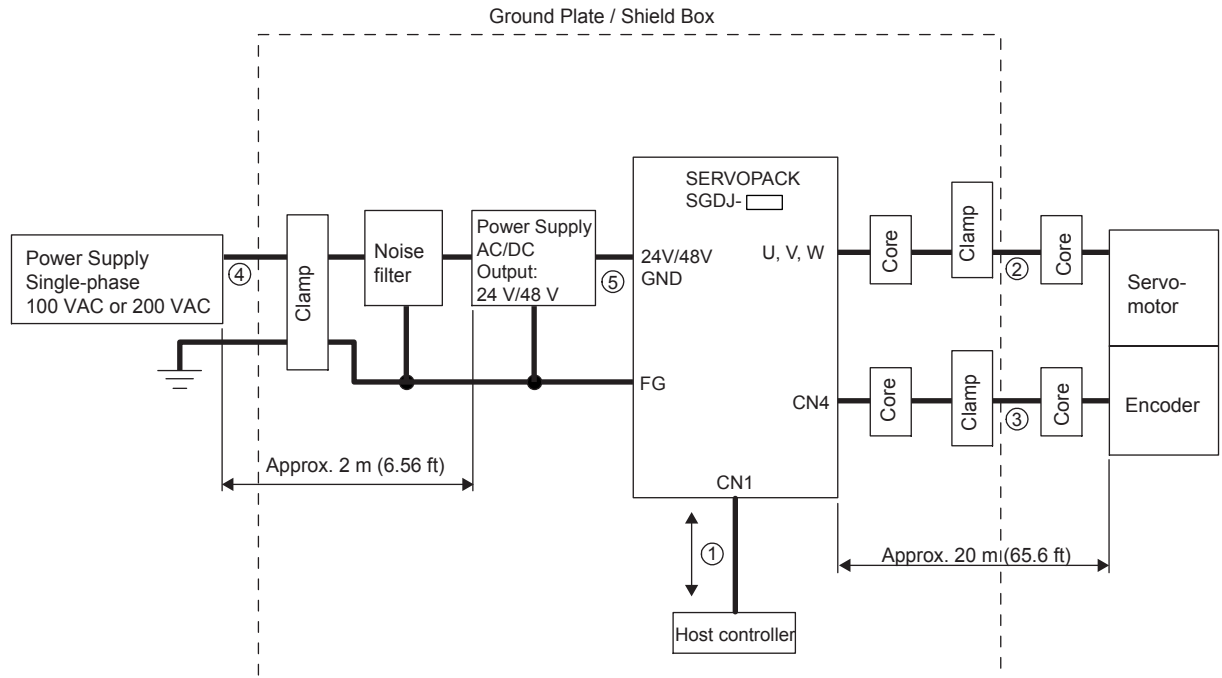

Symbol	Cable Name	Specifications
①	Controller cable	Shield cable
②	Motor cable	Shield cable
③	Encoder cable	Shield cable
④	AC Line cable	Unshield cable
⑤	DC Line cable	Unshield cable

(2) Cable Core and Cable Clamp

(a) Attaching the Ferrite Core

The diagram shows one turn in the cable.

The table shows the cable and the position where the ferrite core is attached.

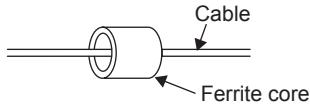

Cable Name	Mounting Position of the Core
Motor cable	Near the SERVOPACK and the servomotor.
Encoder cable	Near the SERVOPACK and the servomotor.

(b) Recommended Ferrite-core

Cable Name	Ferrite Core Model	Manufacturer
I/O signals cable	ESD-SR-25	NEC TOKIN Corporation
Encoder cable		
Motor cable		

(c) Fixing the Cable

Fix and ground the cable shield using a piece of conductive metal.

- Example of Cable Clamp

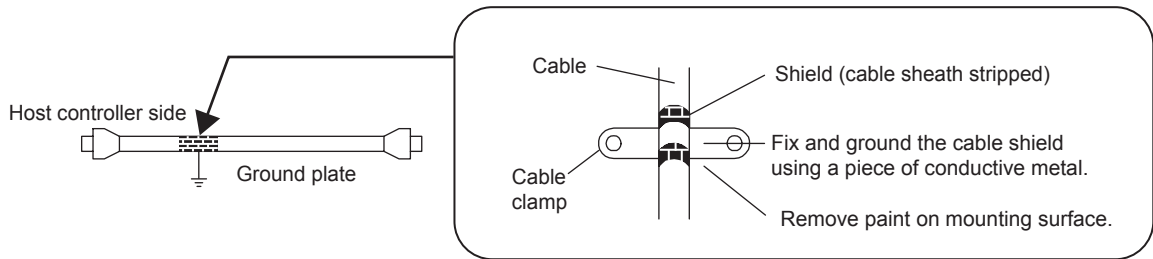

(d) Shield Box

A shield box, which is a closed metallic enclosure, should be used for shielding magnetic interference. The structure of the box should allow the main body, door, and cooling unit to be attached to the ground. The box opening should be as small as possible.

6.4.4 Using More Than One SERVOPACK

The following diagram is an example of the wiring when more than one SERVOPACK is used.

Connect the alarm output (ALM) terminals for the three SERVOPACKs in series to enable alarm detection relay 1RY to operate.

When the alarm occurs, the ALM output signal transistor is turned OFF.

Multiple servos can share a single molded-case circuit breaker (QF) or noise filter. Always select a QF or noise filter that has enough capacity for the total power capacity (load conditions) of those servos. For details, refer to *2.5.2 Molded-case Circuit Breaker and Fuse Capacity*.

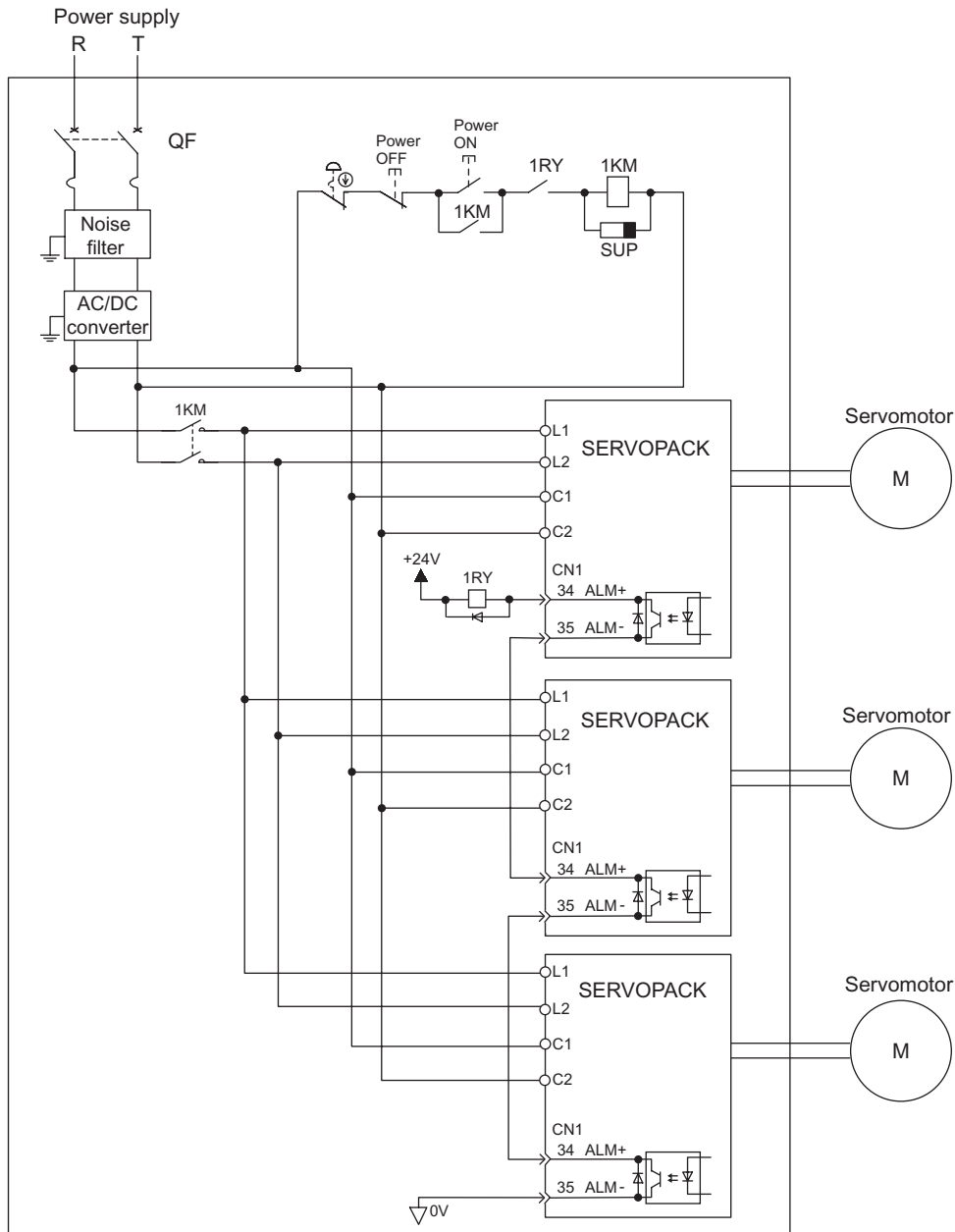

Note: Wire the system, so that the phase-S power supply will be the ground phase.

6.4.5 Extending Encoder Cables

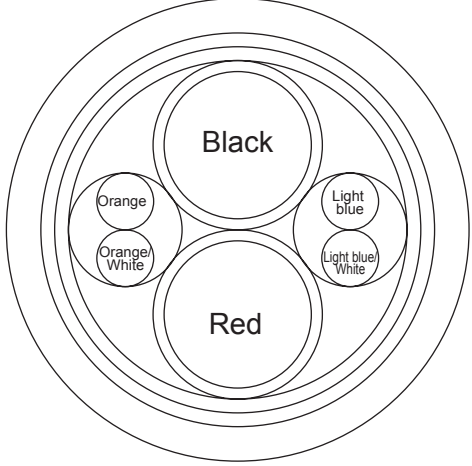

Standard encoder cables have a maximum length of 20 m. If a longer cable is required, prepare an extension cable as described below. The maximum allowable cable length is 50 m.

(1) Specifications for User-modified Cables

Application	Fixed Type
Cable type*	JZSP-CMP19-□□
Cable length	50 m (164.0 ft) max.
Basic Specifications	UL20276 (Max. operating temperature: 80°C (176°F)) AWG16 × 2C + AWG26 × 2P AWG16 (1.31 mm ²) (0.00203 in ²) Insulation covered dimensions: φ 2.0 (0.08 in) AWG26 (0.13 mm ²) (0.000201 in ²) Insulation covered dimensions: φ 0.91 mm (0.04 in)
Finished Dimensions	φ 6.8 mm (0.27 in)
Internal Configuration and Lead Color	
Yaskawa Standards Specifications (Standard Length)	Cable length: 30 m (98.4 ft), 40 m (131.2 ft), 50 m (164.0 ft)

* Specify the cable length in □□ of cable type designation.
(Example) JZSP-CMP19-30 (3 m (98.4 ft))

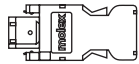
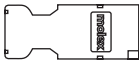
(2) Connectors and Connector kits for User-modified Encoder Cables

Name	Type	Specifications	Reference
SERVOPACK end connector kit	JZSP-CMP9-1		5.4.1
Servomotor end connector kit	JZSP-CMP9-2		5.2.3 5.3.2 5.4.1
Cables	JZSP-CMP19-□	50 m (164.0 ft) max. 	5.4.1

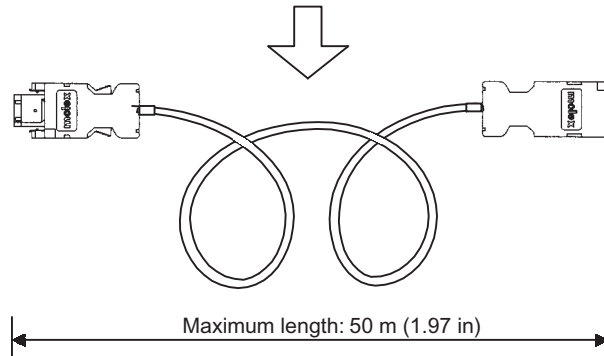

Digital Operator

7.1 Functions on Digital Operator	7-2
7.1.1 Connecting the Digital Operator	7-2
7.1.2 Key Names and Functions	7-3
7.1.3 Basic Mode Selection and Operation	7-4
7.1.4 Status Display	7-5
7.2 Operation in Utility Function Mode (Fn□□□)	7-7
7.2.1 List of Utility Function Modes	7-7
7.2.2 Alarm Traceback Data Display (Fn000)	7-8
7.2.3 Zero-point Search Mode (Fn003)	7-9
7.2.4 Parameter Settings Initialization (Fn005)	7-10
7.2.5 Alarm Traceback Data Clear (Fn006)	7-11
7.2.6 Automatic Offset-adjustment of Motor Current Detection Signal (Fn00E)	7-12
7.2.7 Manual Offset-adjustment of Motor Current Detection Signal (Fn00F)	7-13
7.2.8 Password Setting (Protects Parameters from Being Changed) (Fn010)	7-14
7.2.9 Motor Models Display (Fn011)	7-15
7.2.10 Software Version Display (Fn012)	7-16
7.3 Operation in Parameter Setting Mode (Pn□□□)	7-17
7.3.1 Setting Parameters	7-17
7.3.2 Input Circuit Signal Allocation	7-21
7.3.3 Output Circuit Signal Allocation	7-24
7.4 Operation in Monitor Mode (Un□□□)	7-26
7.4.1 List of Monitor Modes	7-26

7.1 Functions on Digital Operator

This section describes the basic operations of the digital operator (hereinafter called the digital operator) for setting the operating conditions. Set parameters and JOG operation, and display status using these operators. For the detailed operation of the digital operator (Model: JUSP-OP02A-2), refer to Σ -II Series SGM□H/SGDM Digital Operator Operation Manual (TOE-S800-34).

7.1.1 Connecting the Digital Operator

There is no need to turn OFF the SERVOPACK to connect this hand-held operator to the SERVOPACK. Refer to the following illustrations to connect the digital operator to the SERVOPACK.

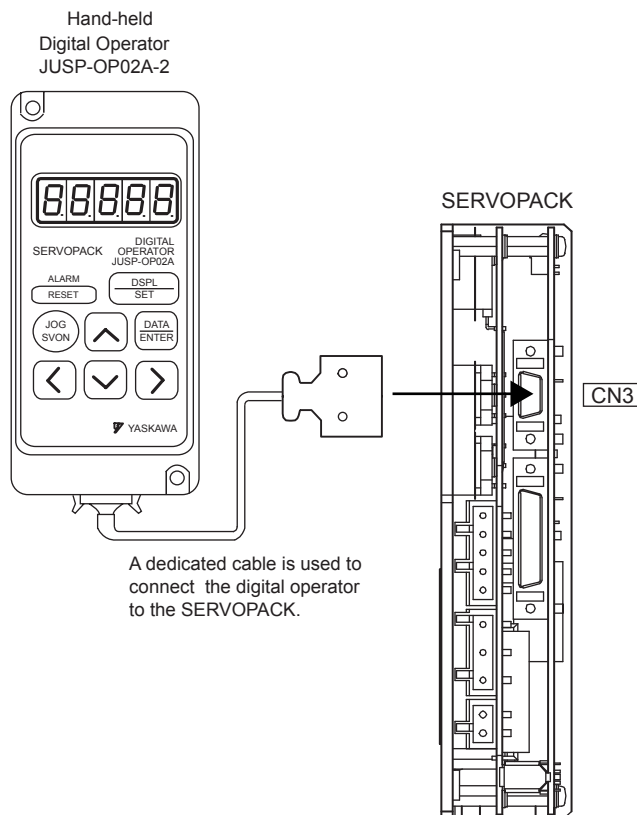







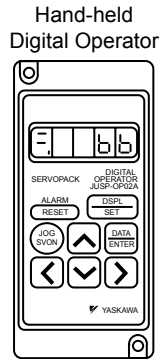

7.1.2 Key Names and Functions

Key names and functions for the digital operator and the panel operator are explained below.

Set parameters and JOG operation, and display status using the panel operator.



Key	Function
 (RESET Key)	To reset the servo alarm. Note 1. The servo alarm can be reset by /ALM-RST (CN1-18) input signal. 2. The servo alarm need not be reset if the control power supply is turned OFF.
 (DSPL/SET Key)	To select a basic mode, such as the status display mode, utility function mode, parameter setting mode, or monitor mode. Can be also used to set the data.
 (DATA/ENTER Key)	To display parameter setting and set value.
 (UP Key)	Press the UP Key to increase the set value. For JOG operation, this key is used as Forward Run Start Key.
 (DOWN Key)	Press the DOWN Key to decrease the set value. For JOG operation, this key is used as Reserve Run Start Key.
 (RIGHT Key)	Press the RIGHT Key to shift to the next digit on the right.
 (LEFT Key)	Press the LEFT Key to shift to the next digit on the left.
 (SVON Key)	Press the SVON Key to perform servo ON/OFF in the JOG operation with the operator.

IMPORTANT

When an alarm occurs, remove the cause, and then reset the alarm. Refer to *10.1 Troubleshooting*.

7.1.3 Basic Mode Selection and Operation

The basic modes include: Status display mode, Utility Function Mode, Parameter Setting Mode, and Monitor Mode.

Select a basic mode to display the operation status, set parameters and operation references.

The basic mode is selected in the following order.

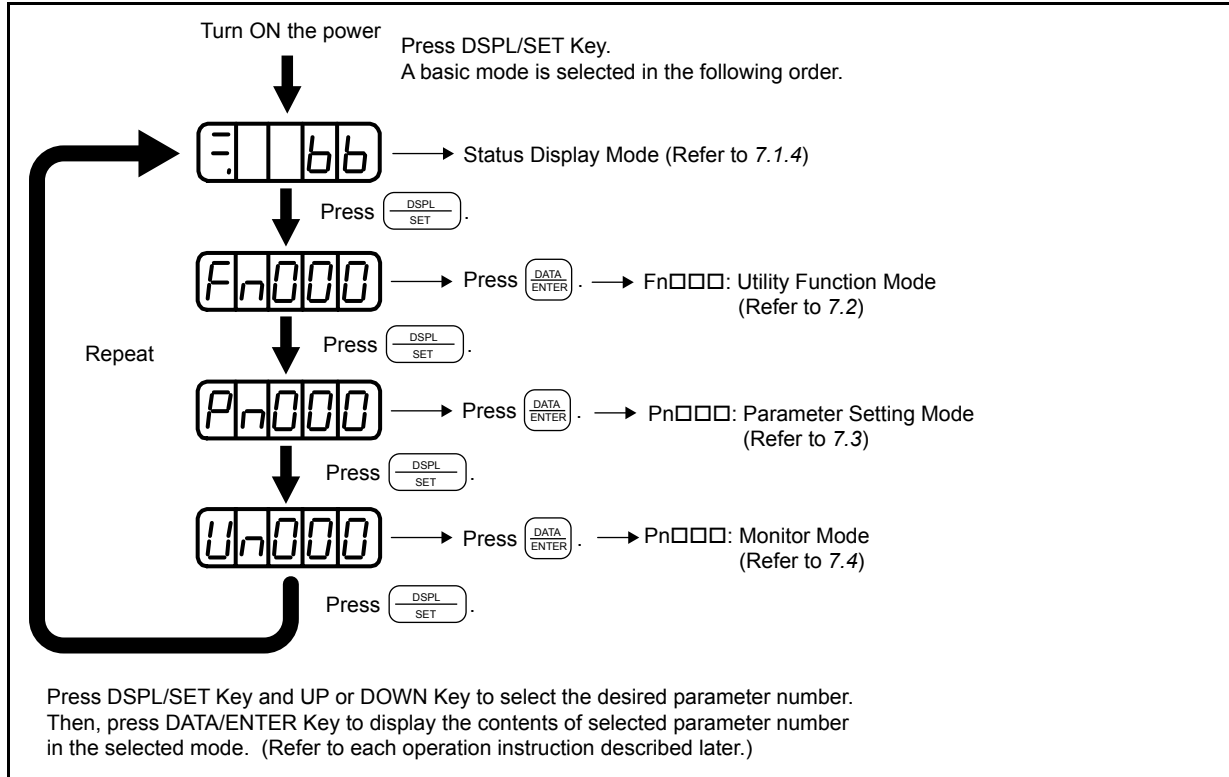

7.1.4 Status Display

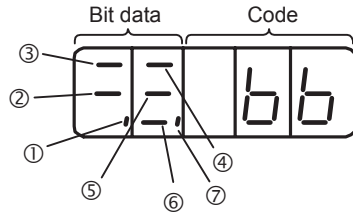

(1) Bit Data and Meanings

Item	SGDJ-□□□S		SGDJ-□□□P	
	Bit Data	Meaning	Bit Data	Meaning
①	Control Power ON	Lit when SERVOPACK control power is ON.	Control Power ON	Lit when SERVOPACK control power supply is ON.
②	Baseblock	Lit for baseblock. Not lit when servo is ON.	Baseblock	Lit for baseblock. Not lit when servo is ON.
③	Speed Coincidence (/V-CMP)	Lit when the difference between the motor speed and reference speed is the same as or less than the value set in Pn503. (Factory setting is 10 min ⁻¹ .) * Always lit in torque control mode.	Positioning Completion (/COIN)	Lit if error between position reference and actual motor position is below preset value. Not lit if error between position reference and actual motor position exceeds preset value. Preset value: Set in Pn500 (Factory setting is 7 pulses.)
④	Rotation Detection (/TGON)	Lit if motor speed exceeds preset value. Not lit if motor speed is below preset value. Preset value: Set in Pn502 (Factory setting is 20 min ⁻¹ .)	Rotation Detection (/TGON)	Lit if motor speed exceeds preset value. Not lit if motor speed is below preset value. Preset value: Set in Pn502 (Factory setting is 20 min ⁻¹ .)
⑤	Speed Reference Input	Lit if input speed reference exceeds preset value. Not lit if input speed reference is below preset value. Preset value: Set in Pn502 (Factory setting is 20 min ⁻¹ .)	Reference Pulse Input	Lit if reference pulse is input. Not lit if no reference pulse is input.
⑥	Torque Reference Input	Lit if input torque reference exceeds preset value. Not lit if input torque reference is below preset value. Preset value: 10% of rated torque	Error Counter Clear Signal Input	Lit when error counter clear signal is input. Not lit when error counter clear signal is not input.
⑦	Power Ready	Lit when main circuit power supply is ON and normal. Not lit when main circuit power supply power is OFF.	Power Ready	Lit when main circuit power supply is ON and normal. Not lit when main circuit power supply power is OFF.

(2) Codes and Meanings

Code	Meaning
bb	Baseblock Servo OFF (motor power OFF)
run	Run Servo ON (motor power ON)
Pot	Forward Run Prohibited CN1-16 (P-OT) is OFF.
not	Reverse Run Prohibited CN1-17 (N-OT) is OFF.
A02	Alarm Status Displays the alarm number.
A03	

7.2 Operation in Utility Function Mode (Fn□□□)

7.2.1 List of Utility Function Modes

This section describes how to apply the basic operations using the panel operator to run and adjust the motor. The following table shows the parameters in the utility function mode.

Parameter No.	Function	Remarks	Reference Section
Fn000	Alarm traceback data display	–	7.2.2
Fn001	Rigidity setting during online autotuning	○	9.2.4
Fn002	JOG mode operation	○	8.1.1
Fn003	Zero-point search mode	○	7.2.3
Fn004	Fixed parameter	○	–
Fn005	Parameter setting initialization	○	7.2.4
Fn006	Alarm traceback data clear	○	7.2.5
Fn007	Writing to EEPROM moment of inertia ratio data obtained from online autotuning	○	9.2.7
Fn008	Absolute encoder multiturn reset and encoder alarm reset	○	8.4.5
Fn009	Automatic tuning of analog (speed, torque) reference offset	○	8.5.3 8.7.3
Fn00A	Manual adjustment of speed reference offset	○	8.5.3
Fn00B	Manual adjustment of torque reference offset	○	8.7.3
Fn00C	Manual zero-adjustment of analog monitor output	○	9.5.2
Fn00D	Manual gain-adjustment of analog monitor output	○	9.5.2
Fn00E	Automatic offset-adjustment of motor current detection signal	○	7.2.6
Fn00F	Manual offset-adjustment of motor current detection signal	○	7.2.7
Fn010	Password setting (protects parameters from being changed)	–	7.2.8
Fn011	Motor models display	–	7.2.9
Fn012	Software version display	–	7.2.10
Fn013	Multiturn limit setting change when a Multiturn Limit Disagreement Alarm (A.CC) occurs	○	8.4.8

Note: When the parameters marked with “○” in remarks column or in Pn□□□ are set for Password Setting (Fn010), the indication shown below appears and such parameters cannot be changed.



7.2.2 Alarm Traceback Data Display (Fn000)

The alarm traceback display can display up to 10 previously occurred alarms. The alarm data is displayed on Fn000, which is stocked in the alarm traceback data. The data can be cleared using an utility function mode “Alarm Traceback Data Clear.” For details, refer to *7.2.5 Alarm Traceback Data Clear (Fn006)*.

The alarm traceback data is not cleared on alarm reset or when the SERVOPACK power is turned OFF. This does not adversely affect operation.



Alarm Sequence Number
The higher the number,
the older the alarm data is.

Alarm Code
See the alarm
table.

The following alarm are operator-related alarms which are not recorded in the traceback data.

Display	Description
	Digital operator transmission error 1
	Digital operator transmission error 2

Refer to *10.1 Troubleshooting* for alarm number and contents.



1. Alarm traceback data will not be updated when the same alarm occurs repetitively.
2. The display “A.--” means no alarm occurs.

Follow the procedure below to confirm alarms which have been generated.

Step	Display after Operation	Key	Description
1		 (DSPL/SET Key)	Press the DSPL/SET Key to select “Alarm Traceback Data Display (Fn000).” If a number other than Fn000 is displayed, press UP Key or DOWN Key to set Fn000. Note: The enabled digit blinks.
2		 (DATA/ENTER Key)	Press the DATA/ENTER Key. The latest alarm data is displayed.
3		 (UP Key)	Press the UP Key to display the data for a previous alarm. (To display one newer alarm data, press DOWN Key.) Note: The higher the digit on the far left, the older the alarm data is.
4		 (UP Key)	Press the UP Key to display value in order. Note: “A.--” means no alarm occurs.
5		 (DATA/ENTER Key)	Press the DATA/ENTER Key. The display will return to Fn000.

7.2.3 Zero-point Search Mode (Fn003)

⚠ CAUTION

- Forward run prohibited (P-OT) and reverse run prohibited (N-OT) signals are disabled during zero-point search mode operations using Fn003.

The zero-point search mode is designed to perform positioning to the zero-point pulse (phase-C) position of the encoder and to clamp at the position.

This mode is used when the motor shaft needs to be aligned to the machine.

Execute the zero-point search without connecting the motor shaft with the machine.

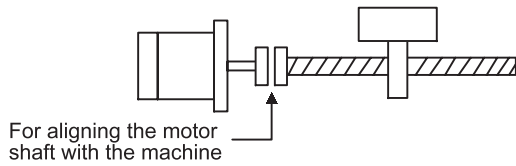

The speed for executing the zero-point search is 60 min^{-1} .

The following conditions must be met to perform the zero-point search operation.

- If the Servo-ON input signal (/S-ON) is ON, turn it OFF.
- Release the Servo-ON signal mask if the parameter Pn 50A.1 is set to 7, and the servo has been set to always be ON.

Follow the procedure below to execute the zero-point search.

Step	Display after Operation	Key	Description
1		 (DSPL/SET Key)	Press the DSPL/SET Key to select the utility function mode.
2			Press the UP or DOWN Key to select the Fn003. Note: The enabled digit blinks.
3		 (DATA/ENTER Key)	Press the DATA/ENTER Key, and the display will be as shown on the left.
4		 (SVON Key)	Press the SVON Key. The servo turns ON.
5			When the parameter is set to Pn000.0 = 0 (default), pressing the UP Key will rotate the motor in the forward direction. Pressing the DOWN Key will rotate the motor in the reverse direction. When the parameter is set to Pn000.0 = 1, the rotation direction of the motor is reversed.
6		Display blinks.	When the motor zero-point search is completed, the display blinks. At this moment, the motor is servo-locked at the zero-point pulse position.
7		 (DATA/ENTER Key)	Press the DATA/ENTER Key. Fn003 display appears again. The motor will be servo OFF status.

7.2.4 Parameter Settings Initialization (Fn005)

This function is used when returning to the factory settings after changing parameter settings.

Pressing the DSPL/SET Key during servo ON does not initialize the parameter settings.

After initialization, turn OFF the power supply and then turn ON again.

IMPORTANT

Initialize the parameter settings with the servo OFF.

Step	Display after Operation	Key	Description
1		 (DSPL/SET Key)	Press the DSPL/SET Key to select the utility function mode.
2			Press the UP or DOWN Key to select Fn005. Note: The enabled digit blinks.
3		 (DATA/ENTER Key)	Press the DATA/ENTER Key, and the display will be as shown on the left.
4		 (DSPL/SET Key)	Press the DSPL/SET Key. Then, the parameters will be initialized. During initialization, the display shown on the left blinks.
5		End of initialization	When the initialization of parameter setting completes, the display shown on the left blinks for about one second.
6		After about one second	The display changes from “donE” to the display shown on the left.
7		 (DATA/ENTER Key)	Press the DATA/ENTER Key to return to the utility function mode display Fn005.

7.2.5 Alarm Traceback Data Clear (Fn006)

This function clears the alarm traceback data, which stores the alarms generated in the SERVOPACK.

After having cleared data, “A.--” (No alarm) is set to all the alarm traceback data.

Step	Display after Operation	Key	Description
1		 (DSPL/SET Key)	Press the DSPL/SET Key to select the utility function mode.
2			Press the UP or DOWN Key to select Fn006. Note: The enabled digit blinks.
3		 (DATA/ENTER Key)	Press the DATA/ENTER Key, and the display will be as shown on the left.
4		 (DSPL/SET Key)	Press the DSPL/SET Key to clear the alarm traceback data. The display shown on the left blinks for about one second when the data is cleared.
5		After about one second	The display changes from “done” to the display shown on the left.
6		 (DATA/ENTER Key)	Press the DATA/ENTER Key to return to the utility function mode display Fn006.









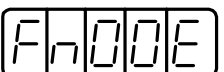

7.2.6 Automatic Offset-adjustment of Motor Current Detection Signal (Fn00E)

Automatic motor current detection offset adjustment has performed at Yaskawa before shipping. Basically, the user need not perform this adjustment.

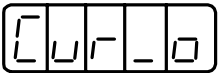
Perform this adjustment only if highly accurate adjustment is required for reducing torque ripple caused by current offset. Automatic adjustment is possible only with power supplied to the main circuit power supply and with the servo OFF.

IMPORTANT

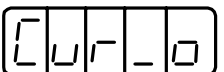
Execute the automatic offset adjustment if the torque ripple is too big when compared with that of other SERVOPACKs.

Step	Display after Operation	Key	Description
1		 (DSPL/SET Key)	Press the DSPL/SET Key to select the utility function mode.
2			Press the UP or DOWN Key to select Fn00E. Note: The enabled digit blinks.
3		 (DATA/ENTER Key)	Press the DATA/ENTER Key, and the display will be as shown on the left.
4		 (DSPL/SET Key)	Press the DSPL/SET Key. The offset will be automatically adjusted. When the adjustment completes, the display shown on the left blinks for about one second.
5		After about one second	The display changes from “donE” to the display shown on the left.
6		 (DATA/ENTER Key)	Press the DATA/ENTER Key to return to the utility function mode display Fn00E.

7.2.7 Manual Offset-adjustment of Motor Current Detection Signal (Fn00F)

The adjusting range of the motor current detection offset is -512 to +511.

To adjust the offset, perform the automatic adjustment (Fn00E) first.

And if the torque ripple is still big after the automatic adjustment, perform the manual adjustment.

IMPORTANT

If this function, particularly manual adjustment, is executed carelessly, it may worsen the characteristics. When performing manual adjustments, run the motor at a speed of approximately 100 min^{-1} , and adjust the operator until the torque monitor ripple is minimized. (Refer to 9.5 *Analog Monitor*.) Adjust the phase-U and phase-V offsets alternately several times until these offsets are well balanced.

Step	Display after Operation	Key	Description
1		 (DSPL/SET Key)	Press the DSPL/SET Key to select the utility function mode.
2			Press the UP or DOWN Key to select Fn00F. Note: The enabled digit blinks.
3		 (DATA/ENTER Key)	Press the DATA/ENTER Key, and the display will be as shown on the left (phase U).
4			Press the LEFT or RIGHT Key to display the phase-U offset amount.
5			Press the UP or DOWN Key to adjust the offset. Carefully adjust the offset while monitoring the torque reference monitor signal.
6			Press the LEFT or RIGHT Key. The display shown on the left appears.
7		 (DSPL/SET Key)	Press the DSPL/SET Key. The display shown on the left appears (phase V).
8			Press the LEFT or RIGHT Key to display the phase-V offset amount.
9			Press the UP or DOWN Key to adjust the offset. Carefully adjust the offset while monitoring the torque reference monitor signal.
10			Press the LEFT or RIGHT Key. The display shown on the left appears.
11		 (DATA/ENTER Key)	When the offset adjustment completes, press the DATA/ENTER Key. The display returns to the utility function mode display Fn00F.

7.2.8 Password Setting (Protects Parameters from Being Changed) (Fn010)

The write prohibited setting is used for preventing accidental changes of the parameter. All the parameters Pn□□□ and some of Fn□□□ become write prohibited by setting values. Refer to 7.2.1 *List of Utility Function Modes* for details.

Setting values are as follows:

- “0000”: Write permitted (Releases write prohibited mode.)
- “0001”: Write prohibited (Parameters become write prohibited from the next power ON.)

Step	Display after Operation	Key	Description
1		 (DSPL/SET Key)	Press the DSPL/SET Key to select the utility function mode.
2			Press the UP or DOWN Key to select Fn010. Note: The enabled digit blinks.
3		 (DATA/ENTER Key)	Press the DATA/ENTER Key, and the display will be as shown on the left.
4			Press the UP or DOWN Key to set a value: “0000”: Write permitted, “0001”: Write prohibited
5		 (DSPL/SET Key)	Press the DSPL/SET Key to register the value. When the value is registered, the display shown on the left blinks for about one second. Note: If a value other than “0000” and “0001” is set, “Error” blinks for about one second, and the previous setting is displayed.
6		After about one second	The display changes from “donE” to “P.000□.”
7		 (DATA/ENTER Key)	Press the DATA/ENTER Key to return to the utility function mode display Fn010.











7.2.9 Motor Models Display (Fn011)

This mode is used for motor maintenance, set the parameter Fn011 to select the motor model check mode. If the SERVOPACK has been custom-made, you can also check the specification codes of SERVOPACKs.

Step	Display after Operation	Key	Description																												
1		 (DSPL/SET Key)	Press the DSPL/SET Key to select the utility function mode.																												
2			Press the UP or DOWN Key to select Fn011. Note: The enabled digit blinks.																												
3		 (DATA/ENTER Key)	Press the DATA/ENTER Key to display the servomotor model and voltage code. <table border="1" style="margin-left: auto; margin-right: auto;"> <thead> <tr> <th colspan="2">Motor Voltage</th> <th colspan="2">Motor Type</th> </tr> <tr> <th>Data</th> <th>Model</th> <th>Data</th> <th>Model</th> </tr> </thead> <tbody> <tr> <td>00</td> <td>Reserved</td> <td>0D</td> <td>SGMAJ</td> </tr> <tr> <td>01</td> <td>Reserved</td> <td>0F</td> <td>Not defined</td> </tr> <tr> <td>02</td> <td>Reserved</td> <td></td> <td></td> </tr> <tr> <td>03</td> <td>24 VDC</td> <td></td> <td></td> </tr> <tr> <td>04</td> <td>48 VDC</td> <td></td> <td></td> </tr> </tbody> </table> <p>Note: "0F" is displayed when using SGMMJ servomotor. But it does not effect the operation.</p>	Motor Voltage		Motor Type		Data	Model	Data	Model	00	Reserved	0D	SGMAJ	01	Reserved	0F	Not defined	02	Reserved			03	24 VDC			04	48 VDC		
Motor Voltage		Motor Type																													
Data	Model	Data	Model																												
00	Reserved	0D	SGMAJ																												
01	Reserved	0F	Not defined																												
02	Reserved																														
03	24 VDC																														
04	48 VDC																														
4		 (DSPL/SET Key)	Press the DSPL/SET Key to display the servomotor capacity. <table border="1" style="margin-left: auto; margin-right: auto;"> <thead> <tr> <th colspan="2">Encoder Type</th> <th colspan="2">Motor Type</th> </tr> <tr> <th>Data</th> <th>Type</th> <th>Data</th> <th>Resolution</th> </tr> </thead> <tbody> <tr> <td>00</td> <td>Incremental</td> <td>13</td> <td>13-bit</td> </tr> <tr> <td>01</td> <td>Absolute</td> <td>16</td> <td>16-bit</td> </tr> <tr> <td></td> <td></td> <td>17</td> <td>17-bit</td> </tr> </tbody> </table> <p>Motor capacity in units of 10 W The above example indicates 100 W.</p>	Encoder Type		Motor Type		Data	Type	Data	Resolution	00	Incremental	13	13-bit	01	Absolute	16	16-bit			17	17-bit								
Encoder Type		Motor Type																													
Data	Type	Data	Resolution																												
00	Incremental	13	13-bit																												
01	Absolute	16	16-bit																												
		17	17-bit																												
5		 (DSPL/SET Key)	Press the DSPL/SET Key, and the encoder type and resolution code will be displayed. <table border="1" style="margin-left: auto; margin-right: auto;"> <thead> <tr> <th colspan="2">Encoder Type</th> <th colspan="2">Motor Type</th> </tr> <tr> <th>Data</th> <th>Type</th> <th>Data</th> <th>Resolution</th> </tr> </thead> <tbody> <tr> <td>00</td> <td>Incremental</td> <td>13</td> <td>13-bit</td> </tr> <tr> <td>01</td> <td>Absolute</td> <td>16</td> <td>16-bit</td> </tr> <tr> <td></td> <td></td> <td>17</td> <td>17-bit</td> </tr> </tbody> </table>	Encoder Type		Motor Type		Data	Type	Data	Resolution	00	Incremental	13	13-bit	01	Absolute	16	16-bit			17	17-bit								
Encoder Type		Motor Type																													
Data	Type	Data	Resolution																												
00	Incremental	13	13-bit																												
01	Absolute	16	16-bit																												
		17	17-bit																												
6		 (DSPL/SET Key)	Press the DSPL/SET Key to display the SERVOPACK's code for custom orders. Note: The display "y.0000" means standard model. <table border="1" style="margin-left: auto; margin-right: auto;"> <thead> <tr> <th colspan="2">Encoder Type</th> <th colspan="2">Motor Type</th> </tr> <tr> <th>Data</th> <th>Type</th> <th>Data</th> <th>Resolution</th> </tr> </thead> <tbody> <tr> <td>00</td> <td>Incremental</td> <td>13</td> <td>13-bit</td> </tr> <tr> <td>01</td> <td>Absolute</td> <td>16</td> <td>16-bit</td> </tr> <tr> <td></td> <td></td> <td>17</td> <td>17-bit</td> </tr> </tbody> </table> <p>Code for custom orders</p>	Encoder Type		Motor Type		Data	Type	Data	Resolution	00	Incremental	13	13-bit	01	Absolute	16	16-bit			17	17-bit								
Encoder Type		Motor Type																													
Data	Type	Data	Resolution																												
00	Incremental	13	13-bit																												
01	Absolute	16	16-bit																												
		17	17-bit																												
7		 (DATA/ENTER Key)	Press the DATA/ENTER Key to return to the utility function mode display Fn011.																												

7.2.10 Software Version Display (Fn012)

Set the Fn012 to select the software-version check mode to check the SERVOPACK and encoder software version numbers.

Step	Display after Operation	Key	Description
1		 (DSPL/SET Key)	Press the DSPL/SET Key to select the utility function mode.
2			Press the UP or DOWN Key to select Fn012. Note: The enabled digit blinks.
3		 (DATA/ENTER Key)	Press the DATA/ENTER Key to display the SERVOPACK software version number.
4		 (DSPL/SET Key)	Press the DSPL/SET Key to display the encoder software version number.
5		 (DATA/ENTER Key)	Press the DATA/ENTER Key to return to the utility function mode Fn012.

7.3 Operation in Parameter Setting Mode (Pn□□□)

Functions can be selected or adjusted by setting parameters. There are two types of parameters. One type requires value setting and the other requires function selection. These two types use different setting methods.

With value setting, a parameter is set to a value within the specified range of the parameter. With function selection, the functions allocated to each digit of the seven-segment LED panel indicator (five digits) can be selected.

7.3.1 Setting Parameters

(1) Value Setting Parameters

(a) Types of Value Setting Parameters

Refer to 10.4.2 List of Parameters.

(b) Example of Changing Value Setting Parameter

The parameter settings can be used for changing parameter data. Before changing the data, check the permitted range of the parameter.

◀ **EXAMPLE** ▶ The example below shows how to change parameter Pn100 (speed loop gain) from “40” to “100.”

Step	Display after Operation	Key	Description
1		 (DSPL/SET Key)	Press the DSPL/SET Key to select the parameter setting mode. If a parameter other than Pn100 is displayed, press the UP or DOWN Key to select Pn100. Note: The enabled digit blinks.
2		 (DATA/ENTER Key)	Press the DATA/ENTER Key. The current data of Pn100 is displayed.
3			Press the LEFT or RIGHT Key to select the digit to be set.
4			Press the UP or DOWN Key to change the data. Keep pressing UP or DOWN Key until “00100” is displayed.
5		 (DATA/ENTER Key)	Press the DATA/ENTER Key. The value blinks and is saved.
6		 (DATA/ENTER Key)	Press the DATA/ENTER Key to return to the display of Pn100. The data for the speed loop gain (Pn100) is changed from “40” to “100.”

(c) Parameter Indications

In this manual, the parameter is explained with using the following format.

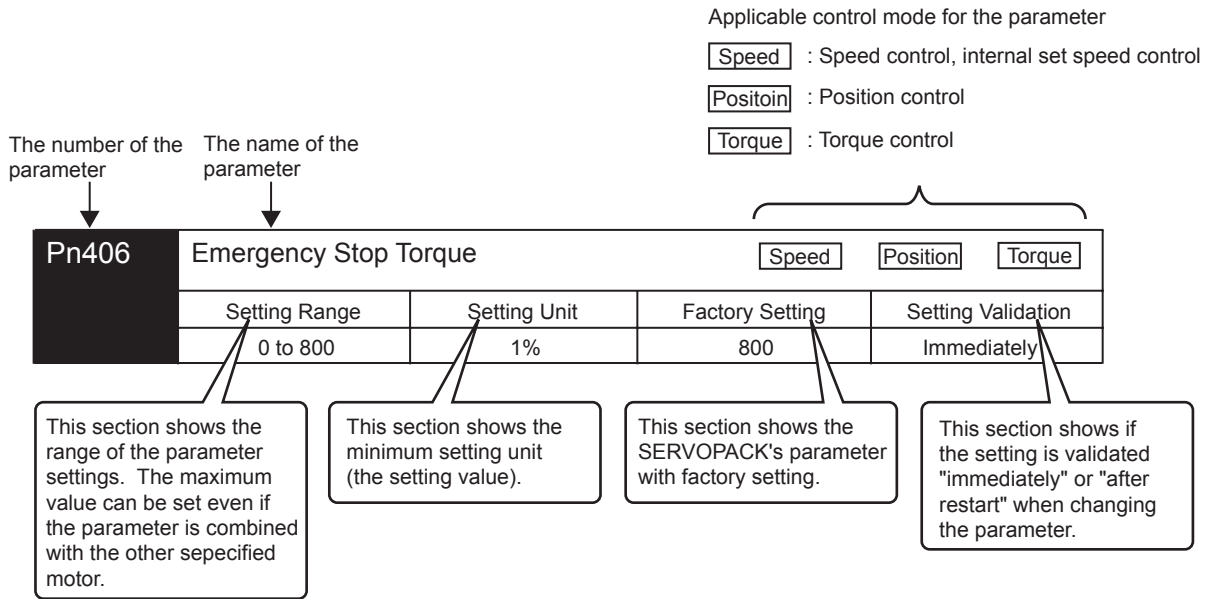

The following alarm shows the setting value of the parameter.

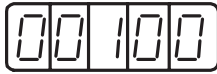

Decimal display in five digits

(2) Function Selection Parameters

(a) Types of Function Selection Parameters

Refer to 10.4.2 List of Parameters.

IMPORTANT

If the parameters with “After restart” in “Setting Validation” column in the table are changed, turn OFF the main circuit and control power supply and ON again to validate new setting.

- Pn10B.1 and Pn110.0 require the power to be reset as mentioned above.
- Pn10B.0, Pn110.1, and Pn110.2 are enabled with the off-line, so the power does not have to be reset.

Category	Parameter No.	Name	Factory Setting		Setting Validation
			SGDJ-□□□S	SGDJ-□□□P	
Function Selection Parameter	Pn000	Function Selection Basic Switches	0000	0010	After restart
	Pn001	Function Selection Application Switches	0100	0100	After restart
	Pn002	Function Selection Application Switches	0000	0000	After restart
	Pn003	Function Selection Application Switches	0002	0002	Immediately
Servo Gain Related Parameter	Pn10B	Gain Application Switches	0000	0000	After restart/ Immediately
	Pn110	Online Autotuning Switches	0010	0010	After restart/ Immediately
Position Control Related Parameter	Pn200	Position Control References Selection Switches	0000	0000	After restart
	Pn207	Position Control Function Switches	0000	0000	After restart
Torque Control Related Parameter	Pn408	Torque Function Switches	0000	0000	Immediately
Sequence Related Parameter (Input Signal Selection)	Pn50A	Input Signal Selections	2100	2100	After restart
	Pn50B	Input Signal Selections	6543	6543	After restart
	Pn50C	Input Signal Selections	8888	8888	After restart
	Pn50D	Input Signal Selections	8888	8888	After restart
Sequence Related Parameter (Output Signal Selection)	Pn50E	Output Signal Selections	3211	3211	After restart
	Pn50F	Output Signal Selections	0000	0000	After restart
	Pn510	Output Signal Selections	0000	0000	After restart
	Pn512	Output Signal Reversal Setting	0000	0000	After restart

(b) Example of Changing Function Selection

The procedure to change the setting of control method selection (Pn000.1) of the function selection basic switches (Pn000) from speed control to torque control is shown below.

Step	Display after Operation	Key	Description
1		 (DSPL/SET Key)	Press the DSPL/SET Key to select the parameter setting mode. If a parameter other than Pn000 is displayed, press the UP or DOWN Key to select the Pn100. Note: The enable digit blinks.
2		 (DATA/ENTER Key)	Press the DATA/ENTER Key. The current data of Pn000 is displayed.
3			Press the LEFT or RIGHT Key to select the first digit of current data.
4		 (UP Key)	Press the UP Key once to change to "n.0010." (Set the control method to position control.)
5		 (DATA/ENTER Key)	Press the DATA/ENTER Key. The value blinks and is saved.
6		 (DATA/ENTER Key)	Press the DATA/ENTER Key to return to the display Pn000. The control method is changed to position control.
7	To enable the change in the setting of function selection basic switches (Pn000), turn OFF the power and ON again.		

(c) Parameter Indications

Each digit of the function selection parameters is defined as the hexadecimal display. The parameter display example shows how parameters are displayed in digits for set values.

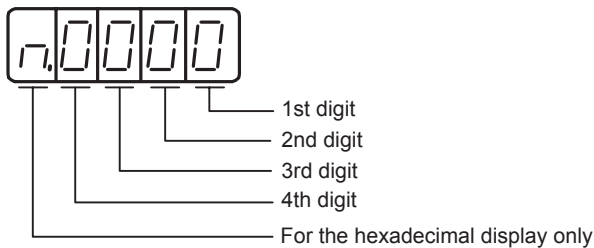

- Pn000.0 or n.xxx□: Indicates the value for the 1st digit of parameter Pn000.
- Pn000.1 or n.xx□x: Indicates the value for the 2nd digit of parameter Pn000.
- Pn000.2 or n.x□xx: Indicates the value for the 3rd digit of parameter Pn000.
- Pn000.3 or n.□xxx: Indicates the value for the 4th digit of parameter Pn000.

For details on each digit of the parameter, see *10.4.2 List of Parameters*.

Parameter		Meaning
Pn50A	n.2□□□	Input the forward run prohibited signal (P-OT) from CN1-16 (Factory setting).
	n.8□□□	Forward run prohibited signal (P-OT) is disabled (Forward rotation allowed).

The number of the parameter

This blank shows the setting value of the function selection, as well as the state condition on the digital operator (JUSP-OP02A-2).

This section explains the details of the function selection.

7.3.2 Input Circuit Signal Allocation

Each input signal is allocated to a pin of the input connector CN1 by setting the parameter.

The following table shows detailed allocation.

(1) Factory Setting (Pn50A.0 = 0)

The factory setting for the input signal allocation is as follows.

means factory setting.

Pn50A:

n	2	1	0	0
---	---	---	---	---

 Pn50B:

n	6	5	4	3
---	---	---	---	---

(2) Changing the Allocation (Pn50A.0 = 1)

Set the parameter in accordance with the relation between the signal to be used and the input connector pin. After having changed the parameter, turn OFF the power and ON again to enable the parameters.

means factory setting.





Signal Name Parameter Setting Allocation	Valid-ity Level	Input Signal	CN1 Input Pin Allocation								Connection Not Required (SERVOPACK judges the connection)	
			14	15	16	17	18	11	12	Always ON	Always OFF	
Servo ON Pn50A.1 = n.xx□x	L	/S-ON	0	1	2	3	4	5	6	7	8	
	H	S-ON	9	A	B	C	D	E	F			
Proportional Operation Reference Pn50A.2 = n.x□xx	L	/P-CON	0	1	2	3	4	5	6	7	8	
	H	P-CON	9	A	B	C	D	E	F			
Forward Run Prohibited Pn50A.3 = n.□xxx	H	P-OT	0	1	2	3	4	5	6	7	8	
	L	/P-OT	9	A	B	C	D	E	F			
Reverse Run Prohibited Pn50B.0 = n.xxx□	H	N-OT	0	1	2	3	4	5	6	7	8	
	L	/N-OT	9	A	B	C	D	E	F			
Alarm Reset Pn50B.1 = n.xx□x	L	/ARM-RST	0	1	2	3	4	5	6	-	8	
	H	ARM-RST	9	A	B	C	D	E	F			
Forward External Torque Limit Pn50B.2 = n.x□xx	L	/P-CL	0	1	2	3	4	5	6	7	8	
	H	P-CL	9	A	B	C	D	E	F			
Reserve External Torque Limit Pn50B.3 = n.□xxx	L	/N-CL	0	1	2	3	4	5	6	7	8	
	H	N-CL	9	A	B	C	D	E	F			
Internal Set Speed Selection Pn50C.0 = n.xxx□	L	/SPD-D	0	1	2	3	4	5	6	7	8	
	H	SPD-D	9	A	B	C	D	E	F			
Internal Set Speed Selection Pn50C.1 = n.xx□x	L	/SPD-A	0	1	2	3	4	5	6	7	8	
	H	SPD-A	9	A	B	C	D	E	F			
Internal Set Speed Selection Pn50C.2 = n.x□xx	L	/SPD-B	0	1	2	3	4	5	6	7	8	
	H	SPD-B	9	A	B	C	D	E	F			
Control Method Selection Pn50C.3 = n.□xxx	L	/C-SEL	0	1	2	3	4	5	6	7	8	
	H	C-SEL	9	A	B	C	D	E	F			
Zero Clamp Pn50D.0 = n.xxx□	L	/ZCLAMP	0	1	2	3	4	5	6	7	8	
	H	ZCLAMP	9	A	B	C	D	E	F			
Reference Pulse Inhibit Pn50D.1 = n.xx□x	L	/INHIBIT	0	1	2	3	4	5	6	7	8	
	H	INHIBIT	9	A	B	C	D	E	F			
Gain Changeover Pn50D.2 = n.x□xx	L	/G-SEL	0	1	2	3	4	5	6	7	8	
	H	G-SEL	9	A	B	C	D	E	F			







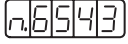





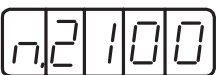

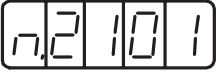



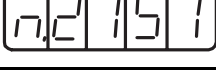

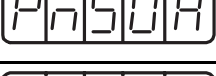

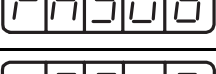
IMPORTANT

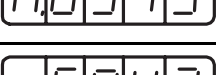
1. When using Servo ON, Forward Run Prohibited, and Reverse Run Prohibited signals with the setting "Polarity Reversal," the machine may not move to the specified safe direction at occurrence of failure such as signal line disconnection. If such setting is absolutely necessary, confirm the operation and observe safety precautions.
2. When two or more signals are allocated to the same input circuit, the input signal level will be applied to all the allocated signal.

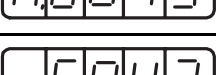
(3) Allocating Input Signals

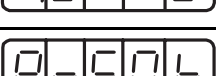
◀ **EXAMPLE** ▶ The procedure to replace Servo ON (/S-ON) signal allocated to CN1-14 and Forward External Torque Limit (/P-CL) allocated to CN1-11 is shown below.

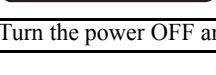
Before → After
 Pn50A:  → 
 Pn50B:  → 

Step	Display after Operation	Key	Description
1		 (DSPL/SET Key)	Press the DSPL/SET Key to select the “value setting parameter” mode. If a parameter other than Pn50A is displayed, press the UP or DOWN Key to set Pn50A. Note: The enabled digit blinks.
2		 (DATA/ENTER Key)	Press the DATA/ENTER Key to display the current data of Pn50A. (/S-ON is allocated to CN1-14.)
3		 (UP Key)	Press the UP Key to set to “1.” (Sequence input signals can be freely set.)
4			Press the LEFT or RIGHT Key to select the second digit from the right. Press the UP key to set to “5.” (Changes the allocation of /S-ON from CN1-14 to CN1-11.)
5		 (DATA/ENTER Key)	Press the DATA/ENTER Key. The value blinks and is saved. At the moment, the CN1-11 operates with OR logic for /S-ON and /P-CL.
6		 (DATA/ENTER Key)	Press the DATA/ENTER Key to return to the display Pn50A.
7		 (UP Key)	Press the UP Key to set Pn50B. Note: The enabled digit blinks.
8		 (DATA/ENTER Key)	Press the DATA/ENTER Key to display the current data of Pn50B. (/P-CL is allocated to CN1-11.)
9			Press the LEFT or RIGHT Key to select the third digit from the right. Press the DOWN Key to set to “0.” (Changes the allocation of /P-CL from CN1-11 to CN1-40.)
10		 (DATA/ENTER Key)	Press the DATA/ENTER Key. The value blinks and is saved.
11		 (DATA/ENTER Key)	Press the DATA/ENTER Key to return to the display Pn50B. /S-ON is allocation to CN1-11, and /P-CL is allocated to CN1-14.
12	Turn the power OFF and ON again to enable the change of input signal selections (Pn50A and Pn50B).		

7.3.3 Output Circuit Signal Allocation

Functions can be allocated to the following sequence output signals. After having changed the parameter, turn OFF the power and ON again to enable the parameters.

means factory setting.



CN1 Pin No.		8/(10)		9/(10)		7/(10)		Remark
Parameter Setting Allocation		Pn512=n.xxx□		Pn512=n.xx□x		Pn512=n.x□xx		
		0	1	0	1	0	1	
Positioning Completion (/COIN) Pn50E.0 = n.xxx□	0	Invalid						L: Valid output signal: Low level H: Valid output signal: High level Invalid: Do not use the output signal. ■ Factory Setting Pn50E: <input type="text" value="n.3211"/> Pn50F: <input type="text" value="n.0000"/> Pn510: <input type="text" value="n.0000"/> Pn512: <input type="text" value="n.0000"/> Note: The output signals for Positioning Completion Signal and Speed Coincidence Detection Signal differ depending on the control method.
	1	L	H					
	2			L	H			
	3					L	H	
Speed Coincidence Detection (/V-CMP) Pn50E.1 = n.xx□x	0	Invalid						
	1	L	H					
	2			L	H			
	3					L	H	
Rotation Detection (/TGON) Pn50E.2 = n.x□xx	0	Invalid						
	1	L	H					
	2			L	H			
	3					L	H	
Servo Ready (/S-RDY) Pn50E.3 = n.□xxx	0	Invalid						
	1	L	H					
	2			L	H			
	3					L	H	
Torque Limit Detection (/CLT) Pn50F.0 = n.xxx□	0	Invalid						
	1	L	H					
	2			L	H			
	3					L	H	
Speed Limit Detection (/VLT) Pn50F.1 = n.xx□x	0	Invalid						
	1	L	H					
	2			L	H			
	3					L	H	
Brake (/BK) Pn50F.2 = n.x□xx	0	Invalid						
	1	L	H					
	2			L	H			
	3					L	H	
Warning (/WARN) Pn50F.3 = n.□xxx	0	Invalid						
	1	L	H					
	2			L	H			
	3					L	H	
Near (/NEAR) Pn510.0 = n.xxx□	0	Invalid						
	1	L	H					
	2			L	H			
	3					L	H	







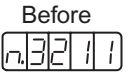











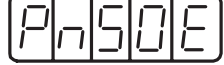

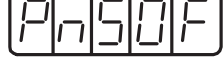
IMPORTANT

- When two or more signals are allocated to the same output circuit, a signal is output with OR logic.
- The signals not detected are considered as "Invalid." For example, Positioning Completion (/COIN) Signal in the SGDJ-□□□S speed control mode is "Invalid."

• Allocating Output Signals

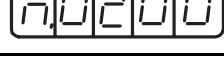
◀ **EXAMPLE** ▶ The procedure to replace Rotation Detection (/TGON) signal allocated to CN1-9 (10) with factory setting to “Invalid” and allocate Brake Interlock (/BK) signal to CN1-9 (10) is shown below.

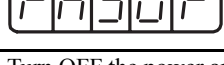
Pn50E:  → 

Step	Display after Operation	Key	Description
1		 (DSPL/SET Key)	Press the DSPL/SET Key to select the “value setting parameter” mode. If a parameter other than Pn50E is displayed, press the UP or DOWN Key to select Pn50E. Note: The enabled digit blinks.
2		 (DATA/ENTER Key)	Press the DATA/ENTER Key to display the current data of Pn50E. (/TGON is allocated to CN1-9 (10).)
3			Press the LEFT Key or RIGHT Key to select the third digit from the right. Press the DOWN Key to set “0.” (Sets /TGON “Invalid.”)
4		 (DATA/ENTER Key)	Press the DATA/ENTER Key. The value blinks and is saved.
5		 (DATA/ENTER Key)	Press the DATA/ENTER Key to return to the display Pn50E.
6		 (UP Key)	Press the UP Key to set Pn50F. Note: The enabled digit blinks.
7		 (DATA/ENTER Key)	Press the DATA/ENTER Key to display the current data of Pn50F. (/BK is set to “Invalid.”)
8			Press the LEFT or RIGHT Key to select the third digit from the right. Press the UP Key to set “2.” (Allocates /BK to CN1-9 (10).)
9		 (DATA/ENTER Key)	Press the DATA/ENTER Key. The value blinks and is saved.
10		 (DATA/ENTER Key)	Press the DATA/ENTER Key to return to the display Pn50F. /TGON is set as “Invalid” and /BK is allocated to CN1-9 (10).
11	Turn OFF the power and ON again to enable the changes of output signal selection (Pn50E and Pn50F).		

7.4 Operation in Monitor Mode (Un□□□)

The monitor mode can be used for monitoring the reference values, I/O signal status, and SERVOPACK internal status.

The monitor mode can be selected during motor operation.

7.4.1 List of Monitor Modes

(1) Contents of Monitor Mode Display

Parameter No.	Content of Display	Unit
Un000	Actual motor speed	min ⁻¹
Un001	Input speed reference (Valid only in speed control mode)	min ⁻¹
Un002	Internal torque reference (in percentage to the rated torque)	%
Un003	Rotation angle 1 (32-bit decimal code)	Number of pulses from the zero-point
Un004	Rotation angle 2 (Angle from the zero-point (electrical angle))	deg
Un005	Input signal monitor *1	—
Un006	Output signal monitor *1	—
Un007	Input reference pulse speed (valid only in position control mode)	min ⁻¹
Un008	Error counter value (amount of position error) (valid only in position control mode)	reference unit
Un009	Accumulated load rate (value for the rated torque as 100 %. Displays effective torque in 10-s cycle.)	%
Un00A	Regenerative load rate (value for the processable regenerative power as 100 %. Displays regenerative power consumption in 10-s cycle.)	%
Un00B	Power consumed by DB resistance (Value for the processable power when dynamic brake is applied as 100 %. Displays power consumed by DB resistance in 10-s cycle.)	%
Un00C	Input reference pulse counter (32-bit hexadecimal code) (valid only in position control mode) *2	—
Un00D	Feedback pulse counter (Data as four times of the encoder pulse number: 32-bit hexadecimal code) *2	—

* 1. Refer to (2) *Sequence I/O Signal Monitor Display*.

* 2. Refer to (4) *Monitor Display of Reference Pulse Counter and Feedback Pulse Counter*.

(2) Sequence I/O Signal Monitor Display

The following section describes the monitor display for sequence I/O signals.

(a) Input Signal Monitor Display

The status of input signal allocated to each input terminal is displayed:

When the input is in OFF (open) status, the top segment (LED) is lit.

when the input is in ON (short-circuited) status, the bottom segment (LED) is lit.



Refer to 7.3.2 *Input Circuit Signal Allocation* for the relation between input terminals and signals.

Display LED Number	Input Terminal Name	Factory Setting
1	CN1-14	/S-ON
2	CN1-15	/P-CON
3	CN1-16	P-OT
4	CN1-17	N-OT
5	CN1-18	/ALM-RST
6	CN1-11	/P-CL
7	CN1-12	/N-CL
8	CN1-5 (36)*	SEN

* When using SGDJ-□□□P SERVOPACK for the position control mode, the SEN signal is assigned Pin No.36.

◀ EXAMPLE ▶

- When /S-ON signal is ON (Servo ON at L level)

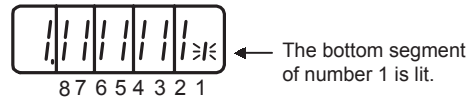

- When /S-ON signal is OFF

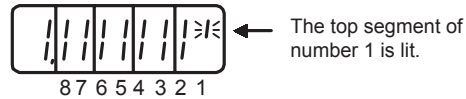

- When P-OT signal operates (Operates at H level)

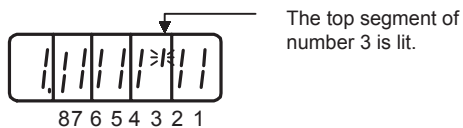

(b) Output Signal Monitor Display

The status of output signal allocated to each output terminal is displayed:

When the output is in OFF (open) status, the top segment (LED) is lit.

When the output is in ON (short-circuited) status, the bottom segment is lit.



Display LED Number	Output Terminal Name	Factory Setting
1	CN1-34, -35	ALM
2	CN1-8, -10	/COIN or /V-CMP
3	CN1-9, -10	/TGON
4	CN1-7, -10	/S-RDY
5	CN1-30	AL01
6	CN1-31	AL02
7	CN1-32	AL03

Seven segments in the top and bottom rows of an LED turn ON and OFF in different combinations to indicate various output signals.

These segments ON for L level and OFF for H level.

◀ EXAMPLE ▶

- When ALM signal operates (alarm at H level.)

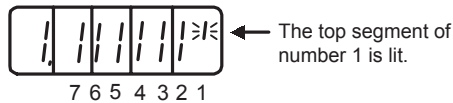
**(3) Operation in Monitor Mode**

The example below shows how to display the contents of monitor number Un000 when the servomotor rotates at 1500 min⁻¹.

Step	Display after Operation	Key	Description
1		 (DSPL/SET Key)	Press the DSPL/SET Key to select the monitor mode.
2			Press the UP or DOWN Key to select the monitor number to be displayed. The display shows the example of the data of Un000.
3		 (DATA/ENTER Key)	Press the DATA/ENTER Key to display the data of Un000.
4		 (DATA/ENTER Key)	Press the DATA/ENTER Key to return to the display of monitor number.

(4) Monitor Display of Reference Pulse Counter and Feedback Pulse Counter

The monitor display of reference pulse counter and feedback pulse counter is expressed in 32-bit hexadecimal.

Step	Display after Operation	Key	Description
1		 (DSPL/SET Key)	Press the DSPL/SET Key to select the monitor mode.
2			Press the UP or DOWN Key to select “Un00C” or “Un00D.”
3	 The upper 16-bit data	 (DATA/ENTER Key)	Press the DATA/ENTER Key to display the data of the selected monitor number.
4	 The lower 16-bit data		Press the UP or DOWN Key to display the lower 16-bit data.
5		 (Press simultaneously)	Press both UP and DOWN Keys simultaneously while the display on the left appears to clear the 32-bit counter data. (The display shown on the left is of the lower 16-bit data.)
6		 (DATA/ENTER Key)	Press the DATA/ENTER Key to return to the display of monitor number.

When the control power supply is turned ON, reference pulse and feedback pulse will be “0.” The counter value increases by forward references, and decreases by reverse references.

Displays the pulse number from 0 to 4294967295 in sequence. If one pulse is decreased from 0, the digital operator and the panel operator display 4294967295 and then decrease from this pulse number. Also, if one pulse is increased from 4294967295, the digital operator and the panel operator display 0 and increase from this pulse number.

The feedback pulse will be 8192 pulse/rev, when using the 13-bit encoder.

The feedback pulse will be 65536 pulse/rev, when using the 16-bit encoder. The feedback pulse will be 131071 pulse/rev, when using the 17-bit encoder.

Operation

8.1 Trial Operation	8-4
8.1.1 Trial Operation for Servomotor without Load	8-6
8.1.2 Trial Operation for Servomotor without Load from Host Reference	8-9
8.1.3 Trial Operation with the Servomotor Connected to the Machine	8-15
8.1.4 Servomotor with Brakes	8-16
8.1.5 Position Control by Host Controller	8-16
8.2 Control Mode Selection	8-17
8.3 Setting Common Basic Functions	8-18
8.3.1 Setting the Servo ON Signal	8-18
8.3.2 Switching the Servomotor Rotation Direction	8-19
8.3.3 Setting the Overtravel Limit Function	8-20
8.3.4 Setting for Holding Brakes	8-22
8.3.5 Selecting the Stopping Method After Servo OFF	8-25
8.3.6 Instantaneous Power Loss Settings	8-26
8.4 Absolute Encoders	8-27
8.4.1 Interface Circuits	8-28
8.4.2 Selecting an Absolute Encoder	8-29
8.4.3 Handling Batteries	8-29
8.4.4 Replacing Batteries	8-29
8.4.5 Absolute Encoder Setup (Fn008)	8-30
8.4.6 Absolute Encoder Reception Sequence	8-31
8.4.7 Multiturn Limit Setting	8-35
8.4.8 Multiturn Limit Setting When Multiturn Limit Disagreement (A.CC) Occurred	8-36
8.5 Operating Using Speed Control with Analog Reference	8-37
8.5.1 Setting Parameters	8-37
8.5.2 Setting Input Signals	8-38
8.5.3 Adjusting Offset	8-39
8.5.4 Soft Start	8-42
8.5.5 Speed Reference Filter	8-42
8.5.6 Using the Zero Clamp Function	8-42
8.5.7 Encoder Signal Output	8-44
8.5.8 Speed Coincidence Output	8-46

8.6 Operating Using Position Control	8-47
8.6.1 Setting Parameters	8-47
8.6.2 Setting the Electronic Gear	8-49
8.6.3 Position Reference	8-52
8.6.4 Smoothing	8-56
8.6.5 Positioning Completed Output Signal	8-57
8.6.6 Positioning Near Signal	8-58
8.6.7 Reference Pulse Inhibit Function (INHIBIT)	8-59
8.7 Operating Using Torque Control	8-60
8.7.1 Setting Parameters	8-60
8.7.2 Torque Reference Input	8-60
8.7.3 Adjusting the Reference Offset	8-61
8.7.4 Limiting Servomotor Speed during Torque Control	8-63
8.8 Operating Using Speed Control with an Internally Set Speed	8-65
8.8.1 Setting Parameters	8-65
8.8.2 Input Signal Settings	8-66
8.8.3 Operating Using an Internally Set Speed	8-66
8.9 Limiting Torque	8-68
8.9.1 Internal Torque Limit (Limiting Maximum Output Torque)	8-68
8.9.2 External Torque Limit (Output Torque Limiting by Input Signals)	8-69
8.9.3 Torque Limiting Using an Analog Voltage Reference	8-71
8.9.4 Torque Limiting Using an External Torque Limit and Analog Voltage Reference	8-72
8.9.5 Checking Output Torque Limiting during Operation	8-73
8.10 Control Mode Selection	8-74
8.10.1 Setting Parameters	8-74
8.10.2 Switching the Control Mode	8-74
8.11 Other Output Signals	8-76
8.11.1 Servo Alarm Output (ALM) and Alarm Code Output (ALO1, ALO2, ALO3)	8-76
8.11.2 Warning Output (/WARN)	8-77
8.11.3 Running Output Signal (/TGON)	8-77
8.11.4 Servo Ready (/S-RDY) Output	8-78



8.1 Trial Operation

Make sure that all wiring has been completed prior to trial operation.

Perform the following three types of trial operation in order. Instructions are given for SGDJ-□□□S speed control mode and SGDJ-□□□P position control mode. Unless otherwise specified, the standard parameters for speed control mode (factory setting) are used.

(1) Trial Operation for Servomotor without Load (Refer to 8.1.1.)

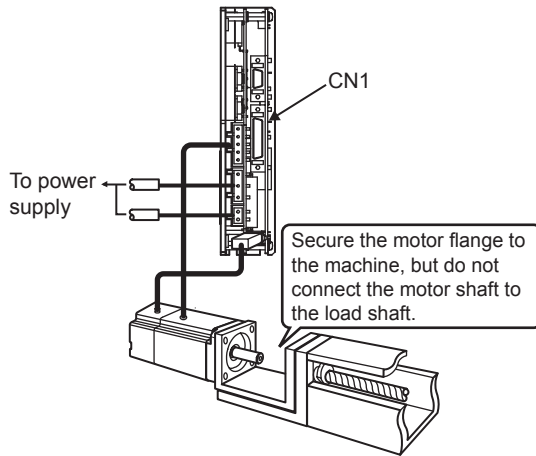

■ Purpose

The servomotor is operated without connecting the shaft to the machine in order to confirm that the following wiring is correct.

- Power supply circuit wiring
- Motor wiring
- Encoder wiring
- Motor's rotation direction and motor speed

(2) Trial Operation for Servomotor with Host Reference (Refer to 8.1.2.)

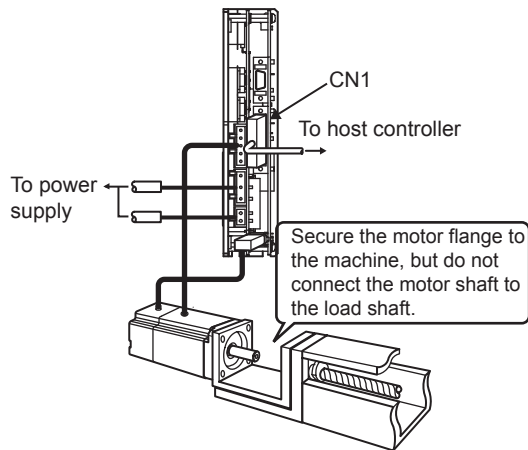

■ Purpose

The servomotor is operated without connecting the shaft to the machine in order to confirm that the following wiring is correct.

- I/O signal wiring between the SERVOPACK and the host controller.
- Motor's rotation direction, motor speed, and number of rotations
- Check the operation of the brake, overtravel, and other protective functions.

(3) Trial Operation for the Servomotor and Machine Combined (Refer to 8.1.3.)

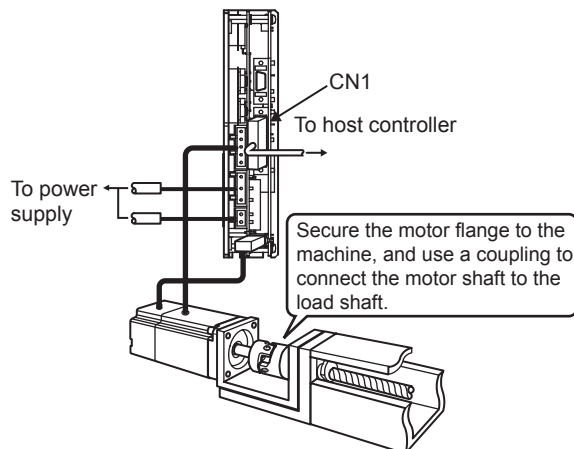

■ Purpose

The servomotor is connected to the machine and trial operation is performed. The SERVOPACK is adjusted to match the machine characteristics.

- The servomotor's rotation direction, motor speed, and machine travel distance.
- Set the necessary parameters.

Step	Item	Description	Reference
1	Installation and mounting	Install the servomotor and SERVOPACK according to the installation conditions. (Do not connect the servomotor to the machine because the servomotor will be operated first under a no-load condition for checking.)	–
↓			
2	Wiring and connections	Connect the power supply circuit (L1 or L2), servomotor wiring (U, V, W), I/O signal wiring (CN1), and encoder wiring (CN4). During (1) <i>Trial Operation for Servomotor without Load</i> , however, disconnect the CN1 connector.	–
↓			
3	Turn ON the power.	Turn ON the power. Check the panel operator to make sure that the SERVOPACK is running normally. If using a servomotor equipped with an absolute encoder, perform the setup for the absolute encoder. (Refer to 8.4.5 <i>Absolute Encoder Setup (Fn008)</i> .)	–
↓			
4	Execute jog mode operation.	Execute jog mode operation with the servomotor alone under a no-load condition.	Jog Operation
↓			
5	Connect input signals.	Connect the input signals (CN1) necessary for trial operation.	–
↓			
6	Check input signals.	Use the internal monitor function to check the input signals. Turn ON the power, and check the emergency stop, brake, overtravel, and other protective functions for correct operation.	–
↓			
7	Input the servo ON signal.	Input the servo ON signal, and turn ON the servomotor.	Host Reference
↓			
8	Input reference.	Input the reference for the control mode being used, and check the servomotor for correct operation.	Host Reference
↓			
9	Check protective operation.	Turn OFF the power, and then connect the servomotor to the machine. If using a servomotor with an absolute encoder, set up the absolute encoder and make the initial settings for the host controller to match the machine's zero position.	–
↓			
10	Set necessary parameters.	Using the same procedure as you did to input a reference in step 8, operate the servomotor from the host controller and set the parameter so that the machine's travel direction, travel distance, and travel speed all correspond to the reference.	Host Reference
↓			
11	Operation	The servomotor can now be operated. Adjust the servo gain if necessary. Refer to 9.1 <i>Autotuning</i> . If a problem occurs, refer to <i>Chapter 10 Inspection, Maintenance, and Troubleshooting</i> .	Host Reference

8.1.1 Trial Operation for Servomotor without Load





CAUTION

- Release the coupling between the servomotor and the machine, and secure only the servomotor without a load.
To prevent accidents, initially perform the trial operation for servomotor under no-load conditions (with all couplings and belts disconnected).

In this section, confirm the cable connections of the main circuit power supply, motor and encoder except the connection to host controller. Incorrect wiring is generally the reason why servomotors fail to operate properly during the trial operation.

Confirm the wiring, and then conduct the trial operation for servomotor without load.

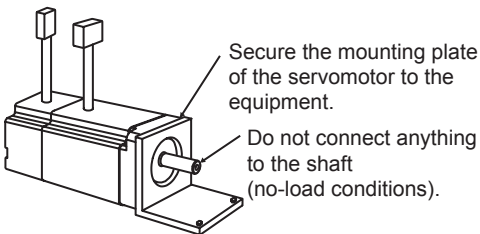
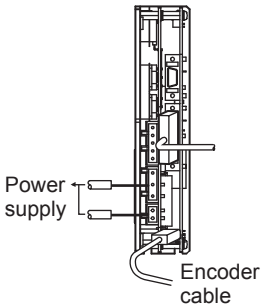
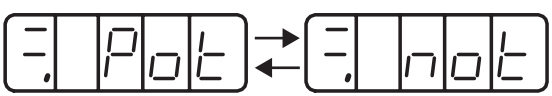





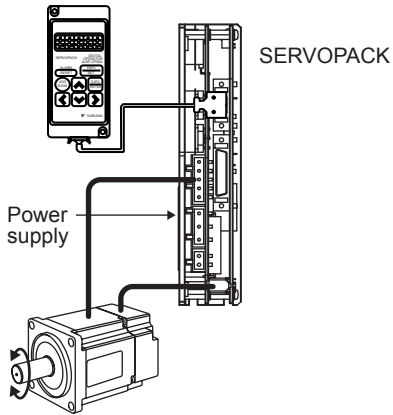







Confirm the display are the same for the optional digital operator (JUSP-OP02A-2).

Step	Description	Check Method and Remarks
1	Secure the servomotor. 	Follow <i>3.3.1 Precautions on Servomotor Installation</i> and secure the servomotor mounting plate to the machine in order to prevent the servomotor from moving during operation. Do not connect the servomotor shaft to the machine. The servomotor may tip over during rotation.
2	Check the power supply circuit, servomotor, and encoder wiring. 	With the CN1 connector not connected, check the power supply circuit and servomotor wiring. Do not use the CN1 I/O signals here. Refer to <i>6.1 Wiring Main Circuit</i> for wiring example of main circuit. Refer to <i>2.4 Selecting Cables</i> for motor and encoder cables.
3	Turn ON power. Normal Display  Alternate display Example of Alarm Display 	If the power is correctly supplied, the digital operator display will appear as shown on the left. The display on the left indicates that Forward Run Prohibited (P-OT) and Reverse Run Prohibited (N-OT). For details, refer to <i>7.1.4 Status Display</i> . If an alarm display appears, the power supply circuit, servomotor wiring, or encoder wiring is incorrect. If an alarm is displayed, turn OFF the power, find the problem, and correct it. Refer to <i>10.1 Troubleshooting</i> .

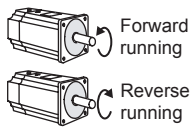
(cont'd)

Step	Description	Check Method and Remarks
4	Release the brake before driving the servomotor when a servomotor with brake is used.	Refer to 8.3.4 <i>Setting for Holding Brakes</i> and 8.4.5 <i>Absolute Encoder Setup (Fn008)</i> . Absolute Encoder Setup (Fn008) operation can be omitted when setting the Pn002 to n.□1□□ (Uses absolute encoder as an incremental encoder) only during trial operation.
5	Operate with the panel operator. 	Use the digital operator to operate the servomotor with utility function Fn002 (Jog Mode Operation). Check that the servomotor rotates in the forward direction by UP key, and reverse direction by DOWN key. The operation is completed when the operation is performed as described below and the alarm display does not appear. Complete the Fn002 (Jog Mode Operation) and turn OFF the power. For operation method of the digital operator, refer to 7.1 <i>Functions on Digital Operator</i> . The servomotor speed can be changed using the Pn304 (JOG Speed). The factory setting for jog speed is 500 min ⁻¹ .

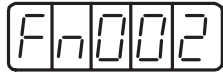
• JOG Mode Operation (Fn002)

Step	Display after Operation	Key	Description
1		 (DSPL/SET Key)	Press the DSPL/SET Key to select the utility function mode.
2			Press the UP or DOWN Key to select Fn002. Note: The digit that can be set will blink.
3		 (DATA/ENTER Key)	Press the DATA/ENTER Key. The display shown at the right will appear, and the servomotor will enter JOG operation mode. The servomotor can be operated with the panel operator in this condition.
4		 (SVON Key)	Press the SVON Key. This will turn ON the power to the servomotor.
5			Press the UP Key (forward) or DOWN Key (reverse). The servomotor will operate as long as the key is pressed.
6		 (DSPL/SET Key)	Press the DSPL/SET Key. This will turn OFF the power to the servomotor. The power will remain OFF even if the SVON Key is pressed.
7		 (DATA/ENTER Key)	Press the DATA/ENTER Key to return to the Fn002 display of the utility function mode.



The servomotor's rotation direction depends on the setting of parameter Pn000.0 (Direction Selection). The example above describes operation with Pn000.0 in the factory setting.

Pn304	JOG Speed			Speed	Position	Torque
	Setting Range	Setting Unit	Factory Setting	Setting Validation		
	0 to 10000	1 min ⁻¹	500	Immediately		
Sets the utility function Fn002 (Jog Mode Operation) to the reference value of motor speed.						

The motor can be operated using only the digital operator without reference from the host controller. The following conditions are required to perform jog mode operation.

1. The servo on (/S-ON) input signal is OFF (H level). Refer to 8.3.1 *Setting the Servo ON Signal*.
2. Pn50A is not set to n.□□7□ (Sets signal ON) with the external input signal allocation. Refer to 7.3.2 *Input Circuit Signal Allocation*.

Pay attention that the Forward Run Prohibited (P-OT) and Reverse Run Prohibited (N-OT) signals are invalid during jog mode operation. For the jog mode operation procedures, refer to the previous page.

8.1.2 Trial Operation for Servomotor without Load from Host Reference

Check that the servomotor move reference or I/O signals are correctly set from the host controller to the SERVOPACK. Also check that the wiring and polarity between the host controller and SERVOPACK, and the SERVOPACK operation settings are correct. This is final check before connecting the servomotor to the machine.



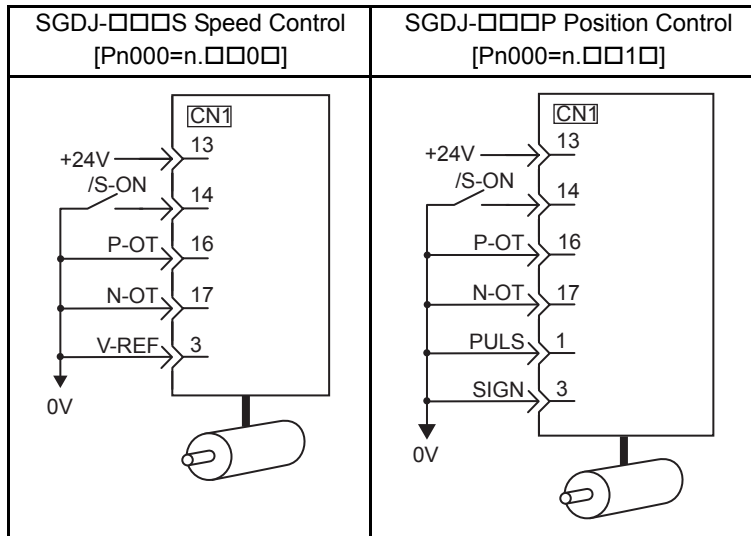

(1) Servo ON Command from the Host

The following circuits are required: External input signal circuit or equivalent.

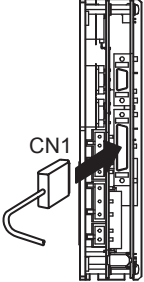

Change the SEN signal (SGDJ-□□□S: CN1-5, SGDJ-□□□P:CN1-36) to the H level when an absolute encoder is used.

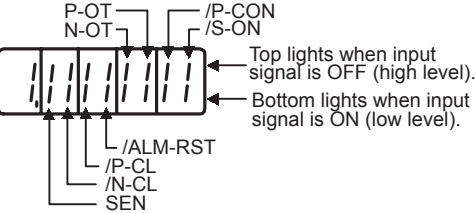
8.1.2 Trial Operation for Servomotor without Load from Host Reference

Step	Description	Check Method and Remarks
1	<p>Configure an input signal circuit necessary for servo ON. Connect the I/O signal connectors (CN1) in the circuit on the previous page or equivalent to input the signal necessary for servo ON. Then turn OFF the power and connect the CN1 to the SERVOPACK.</p> 	<p>Satisfy the following conditions:</p> <ol style="list-style-type: none"> 1. Servo ON (/S-ON) input signal can be input. 2. Forward Run Prohibited (P-OT) and Reverse Run Prohibited (N-OT) input signals are turned ON (L level). (Forward run and reverse run are prohibited.) 3. Reference input (0V reference or 0 pulse) is not input. <p>To omit the external wiring, the input terminal function can be set to “Always ON” or “Always OFF” using the input signal allocation function of parameter. Refer to 7.3.2 <i>Input Circuit Signal Allocation</i>.</p> <p>When the absolute encoder is used, Absolute Encoder Setup (Fn008) operation and the SEN signal wiring can be omitted when setting the Pn002 to n.□1□□ (Uses absolute encoder as an incremental encoder) only during trial operation.</p>
2	<p>Turn ON the power and make sure that the digital operator display is as shown below.</p> 	<p>The input signal setting is not correct if the display is not the same as on the left. Check the input signal using the Un005 (input signal monitor) from the digital operator.</p> <p>Un005 = </p> <p>Check input signal wiring in monitor mode using the digital operator or panel operator. Refer to 7.4.1 <i>List of Monitor Modes</i>.</p> <p>Turn ON and OFF each signal line to see if the LED monitor bit display on the digital operator changes as shown below.</p> <p>Input signal LED display</p>  <p>If an absolute encoder is being used, the servo will not turn ON when the servo ON signal (/S-ON) is input unless the SEN signal is also ON.</p> <p>When the SEN signal is checked in monitor mode, the top of the LED will light because the SEN signal is high when ON.</p>
3	<p>Input the /S-ON signal, then make sure that the display of the digital operator is as shown below.</p> 	<p>If an alarm display appears, correct it according to 10.1 <i>Troubleshooting</i>. If there is noise in the reference voltage during speed control, the horizontal line (-) at the far left edge of the digital operator display may blink. Also the servomotor may turn very slowly. Refer to 6.4 <i>Others</i> and take a preventive measure.</p>

(2) Operating Procedure in Speed Control Mode (Pn000 = n.□□□□)

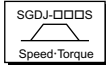

The following circuit is required: External input signal circuit or equivalent.

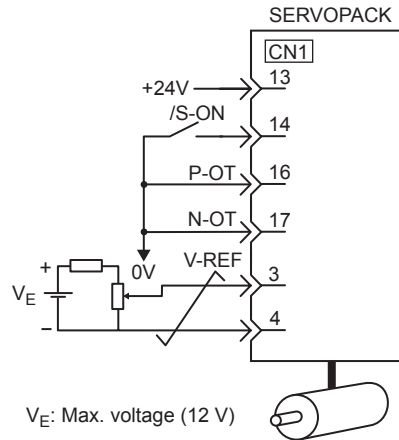

Step	Description	Check Method and Remarks
1	Check the power and input signal circuits again, and check that the speed reference input (voltage between the V-REF and SG) is 0 V.	Refer to the above figure for input signal circuit.
2	Turn ON the servo ON (/S-ON) input signal.	If the servomotor rotates at extremely slow speed, refer to 8.5.3 <i>Adjusting Offset</i> , and use the reference voltage offset to keep the servomotor from moving.
3	Generally increase the speed reference input voltage between V-REF and SG from 0 V.	The factory setting is 6 V/rated rotation speed.
4	Check the speed reference input to the SERVO-PACK (Un000 [min-1]).	Refer to 7.1.3 <i>Basic Mode Selection and Operation</i> for how it is displayed.
5	Check the Un000 (motor speed [min-1]).	Refer to 7.1.3 <i>Basic Mode Selection and Operation</i> for how it is displayed.
6	Check that the Un001 and Un000 values in steps 4 and 5 are equal.	Change the speed reference input voltage and check that Un001 and Un000 values are equal for multiple speed references.
7	Check the speed reference input gain and motor rotation direction.	Refer to the following equation to change the Pn300 (speed reference input gain). $Un001 = (\text{voltage between V-REF}) [V] \times Pn300 [3000 \text{ min-1}/6V]$ To change the motor rotation direction without changing polarity for speed reference input gain, refer to 8.3.2 <i>Switching the Servomotor Rotation Direction</i> . Perform the operation from step 2 again after the motor rotation direction is changed.
8	When the speed reference input is set to 0 V and servo OFF status enters, the trial operation for servomotor without load is completed.	–



■ When Position Control is configured at the Host

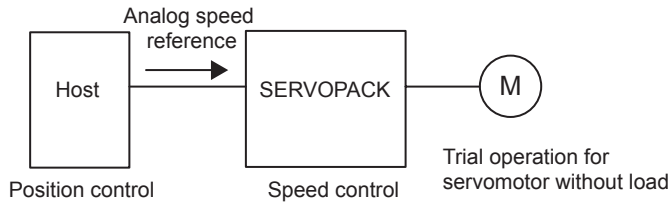

When the SERVOPACK conducts speed control and position control is conducted at the host controller, perform the operations below, following the operations in (2) *Operating Procedure in Speed Control Mode* ($Pn000 = n.\square\square0\square$) on the previous page.

Step	Description	Check Method and Remarks
9	Check the input signal circuit again, and check that the speed reference input (voltage between the V-REF and SG) is 0 V.	Refer to the above figure for input signal circuit.
10	Turn ON the servo ON (/S-ON) input signal.	If the servomotor rotates at extremely slow speed, refer to 8.5.3 <i>Adjusting Offset</i> , and use the reference voltage offset to keep the servomotor from moving.
11	Send the command for the number of motor rotation easy to check (for example, one motor revolution) from the host controller in advance, and check the sent number of rotation and actual number of rotation by visual inspection and the Un003 (rotation angle1)[pulse].	Refer to 7.1.3 <i>Basic Mode Selection and Operation</i> for how it is displayed. Un003 (rotation angle 1)[pulse]: The number of pulses from the zero point.
12	If the sent number of rotation and actual number of rotation in step 11 are not equal, correctly set the Pn201 (PG divided ratio) outputting the encoder pulse from the SERVOPACK.	Refer to 8.5.7 <i>Encoder Signal Output</i> for how to set. PG divider (Pn201 [P/Rev]): The number of encoder pulses per revolution
13	When the speed reference input is set to 0 V and servo OFF status enters, the trial operation for position control with the host controller is completed.	–

(3) Operating Procedure in Position Control Mode (Pn000 = n.□□1□)

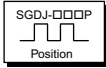

The following circuit is required: External input signal circuit or equivalent.

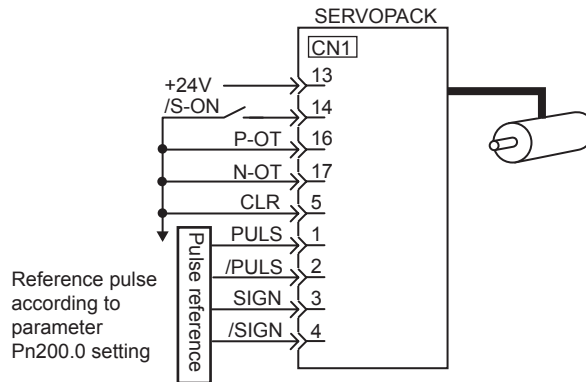

Step	Description	Check Method and Remarks
1	Match the reference pulse form with the pulse output form from the host controller.	Set the reference pulse with Pn200=n.□□□×. Refer to 8.6.1 (2) <i>Setting a Reference Pulse Form</i> .
2	Set the reference unit and electronic gear ration so that it coincides with the host controller setting.	Set the electronic gear ratio with Pn202/Pn203. Refer to 8.6.2 <i>Setting the Electronic Gear</i> .
3	Turn ON the power and the servo ON (/S-ON) input signal.	–
4	Send the pulse reference for the number of motor rotation easy to check (for example, one motor revolution) and with slow speed from the host controller in advance.	Set the motor speed of several 100 min ⁻¹ for the reference pulse speed because such speed is safe.
5	Check the number of reference pulses input to the SERVOPACK by the changed amount before and after the Un00C (input reference pulse counter) [pulse] was executed.	Refer to 7.1.3 <i>Basic Mode Selection and Operation</i> for how it is displayed. Un00C (input reference pulse counter) [pulse]
6	Check the actual number of motor rotation [pulse] by the changed amount before and after the Un003 (rotation angle 1) [pulse] was executed.	Refer to 7.1.3 <i>Basic Mode Selection and Operation</i> for how it is displayed. Un003 (rotation angle 1) [pulse]
7	Check that steps 5 and 6 satisfy the following equation: $Un003 = Un00C \times (Pn202/Pn203)$	–
8	Check that the motor rotation direction is the same as the reference.	Check the input pulse polarity and input reference pulse form. Refer to 8.6.1 (2) <i>Setting a Reference Pulse Form</i> .
9	Input the pulse reference with the large number of motor rotation from the host controller to obtain the constant speed.	Set the motor speed of several 100 min ⁻¹ for the reference pulse speed because such speed is safe.

(cont'd)

Step	Description	Check Method and Remarks
10	Check the reference pulse speed input to the SERVOPACK using the Un007 (input reference pulse speed) [min^{-1}].	Refer to 7.1.3 Basic Mode Selection and Operation for how it is displayed. Un007 (input reference pulse speed) [min^{-1}]
	The number of input reference pulses (Un00C) can be obtained from the following equation. $\text{Un007}(\text{input reference pulse speed}) = \underbrace{\text{input reference pulse [pulses/S]} \times 60}_{\text{Reference input ppm}} \times \underbrace{\frac{\text{Pn202}}{\text{Pn203}}}_{\text{Electronic gear ratio}} \times \underbrace{\frac{1}{2^{13}(8192)}}_{\text{Encoder pulse}^*}$	
	* The encoder pulse differs depending on the model of the servomotor used.	
11	Check the motor speed using the Un000 (motor speed) [min^{-1}].	Refer to 7.1.3 Basic Mode Selection and Operation for how it is displayed. Un000 (motor speed) [min^{-1}]
12	Check that the Un007 and Un000 values in steps 9 and 10 are equal.	–
13	Check the motor rotation direction.	To change the motor rotation direction without changing input reference pulse form, refer to 8.3.2 Switching the Servomotor Rotation Direction. Perform the operation from step 9 again after the motor rotation direction is changed.
14	When the pulse reference input is stopped and servo OFF status enters, the trial operation for servomotor without load and using position control with the host controller is completed.	–

8.1.3 Trial Operation with the Servomotor Connected to the Machine

⚠ WARNING

- Follow the procedure below for trial operation precisely as given.
Malfunctions that occur after the servomotor is connected to the machine not only damage the machine, but may also cause an accident resulting death or injury.

Follow the procedures below to perform the trial operation.

1. Set the necessary parameters according to the machine configuration.
2. Match the direction of rotation and speed to equipment specifications.

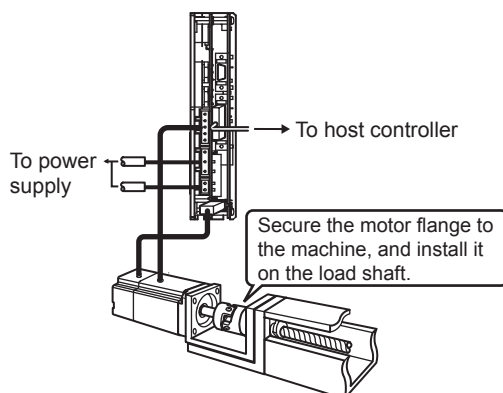

Step	Description	Check Method and Remarks
1	Turn ON the power and make the settings for mechanical configuration related to protective function such as overtravel and brake.	Refer to 8.3 <i>Setting Common Basic Functions</i> . When a servomotor with brake is used, take advance measures to prevent vibration due to gravity acting on the machine or external forces before checking the brake operation. Check that both servomotor and brake operations are correct. For details, refer to 8.3.4 <i>Setting for Holding Brakes</i> .
2	Set the necessary parameters for control mode used.	Refer to 8.5 <i>Operating Using Speed Control with Analog Reference</i> , 8.6 <i>Operating Using Position Control</i> , and 8.7 <i>Operating Using Torque Control</i> for control mode used.
3	Connect the servomotor to the machine with coupling, etc., while the power is turned OFF.	Refer to 3.3.1 <i>Precautions on Servomotor Installation</i> .
4	Check that the SERVOPACK is servo OFF status and then turn ON the power to the machine (host controller). Check again that the protective function in step 1 operates normally.	Refer to 8.3 <i>Setting Common Basic Functions</i> . For steps 4 to 8, take advance measures for emergency stop so that the servomotor can stop safely when an error occurs during operation.
5	Perform trial operation with the servomotor connected to the machine, following each section in 8.1.2 <i>Trial Operation for Servomotor without Load from Host Reference</i> .	Check that the trial operation is completed with as the trial operation for servomotor without load. Also check the settings for machine such as reference unit.
6	Check the settings of parameters for control mode used set in step 2 again.	Check that the servomotor rotates matching the machine operating specifications.

Step	Description	Check Method and Remarks
7	Adjust the servo gain and improve the servomotor response characteristics, if necessary.	Refer to 9.1 <i>Autotuning</i> . The servomotor will not be broken in completely during the trial operation. Therefore, let the system run for a sufficient amount of additional time to ensure that it is properly broken in.
8	Write the parameters set for maintenance in 10.4 <i>List of Parameters</i> . Then the trial operation with the servomotor connected to the machine is completed.	–

8.1.4 Servomotor with Brakes

Holding brake operation of the servomotor with brake can be controlled with the brake interlock output (/BK) signal of the SERVOPACK.

When checking the brake operation, take advance measures to prevent vibration due to gravity acting on the machine or external forces. Check the servomotor operation and holding brake operation with the servomotor separated from the machine. If both operations are correct, connect the servomotor and perform trial operation.

For wiring on a servomotor with brakes and parameter settings, refer to 8.3.4 *Setting for Holding Brakes*.

8.1.5 Position Control by Host Controller

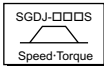

As described above, be sure to separate the servomotor and machine before performing trial operation of the servomotor without a load. Refer to the following table, and check the servomotor operation and specifications in advance.

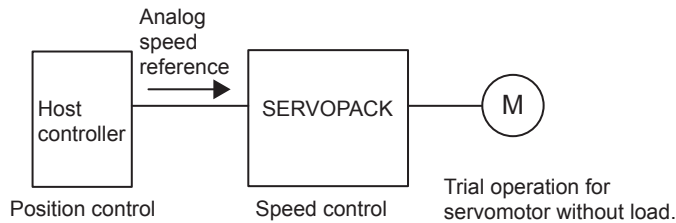

Reference from the Host Controller	Check Item	Check Method	Review Items	Reference Section
JOG Operation (Constant Reference Speed Input from Host Controller)	Motor Speed	Check motor speed as follows: <ul style="list-style-type: none"> Use the motor speed monitor (Un000) on the panel operator. Run the servomotor at low speed. Input a reference speed of 60 min^{-1} for example to check to see if the servomotor makes one revolution per second. 	Check the parameter setting at Pn300 to see if reference speed gain is correct.	8.5.1
Simple Positioning	No. of motor rotation	Input a reference equivalent to one motor rotation and visually check to see if the shaft makes one revolution.	Check the parameter setting at Pn201 to see if the number of PG dividing pulses is correct.	8.5.7
Overtravel (P-OT and N-OT Used)	Whether the servomotor stops rotating when P-OT and N-OT signals are input	Check to see if the servomotor stops when P-OT and N-OT signals are input during continuous servomotor operation.	Review P-OT and N-OT wiring if the servomotor does not stop.	8.3.3

8.2 Control Mode Selection

The control modes supported by the SGDJ SERVOPACK are described below.

Parameter	Control Mode	Applicable SERVOPACK		Reference Section	
		SGDJ- □□□S	SGDJ- □□□P		
Pn000	n.□□0□ (□□□S Factory setting)	Speed Control (Analog voltage speed reference) Controls servomotor speed by means of an analog voltage speed reference. Use in the following instances. • To control speed • For position control using the encoder feedback division output from the SERVOPACK to form a position loop in the host controller.	Applicable	N/A	8.5
	n.□□1□ (□□□P Factory setting)	Position Control (Pulse train position reference) Controls the position of the servomotor by means of a pulse train position reference. Controls the position with the number of input pulses, and controls the speed with the input pulse frequency. Use when positioning is required.	N/A	Applicable	8.6
	n.□□2□	Torque Control (Analog voltage speed reference) Controls the servomotor's output torque by means of an analog voltage torque reference. Use to output the required amount of torque for operations such as pressing.	Applicable	N/A	8.7
	n.□□3□	Speed Control (Contact input speed control) Uses the three input signals /P-CON (/SPD-D), /P-CL (/SPD-A), and /N-CL (/SPD-B) to control the speed as set in advance in the SERVOPACK. Three operating speeds can be set in the SERVOPACK. (In this case, an analog reference is not necessary.)	Applicable	N/A	8.8
	n.□□4□ . . . n.□□B□	These are switching modes for using the four control methods described above in combination. Select the control method switching mode that best suits the application.	Applicable	Applicable	8.10

* If Pn000 = n.□□4□ to n.□□B□, Pn000 is set to switching mode for using the basic control methods in combination. Select the control method switching mode that best suits the application. Some switching modes cannot be selected depending on the SERVOPACK type (SGDJ-□□□S and □□□P). For details, refer to 8.10 Control Mode Selection.

8.3 Setting Common Basic Functions

8.3.1 Setting the Servo ON Signal

This sets the servo ON signal (/S-ON) that determines whether the servomotor power is ON or OFF.

(1) Servo ON signal (/S-ON)

Type	Name	Connector Pin Number	Setting	Meaning
Input	/S-ON	CN1-14 (Factory setting)	ON (low level)	Servomotor power ON. Servomotor can be operated.
			OFF (high level)	Servomotor power OFF. Servomotor cannot be operated.
<p>■ IMPORTANT</p> <p>Always input the servo ON signal before inputting the input reference to start or stop the servomotor. Do not input the input reference first and then use the /S-ON signal to start or stop. Doing so will degrade internal elements and lead to malfunction.</p> <p>Note: A parameter can be used to re-allocate the input connector number for the /S-ON signal. Refer to <i>7.3.2 Input Circuit Signal Allocation</i>.</p>				

(2) Enabling/Disabling the Servo ON Signal

A parameter can be always used to set a parameter servo ON condition. This eliminates the need to wire /S-ON, but care must be taken because the SERVOPACK can operate as soon as the power is turned ON.

Parameter	Meaning
Pn50A n.□□0□	Inputs the /S-ON signal from the input terminal CN1-14. (Factory setting)
n.□□7□	Constantly enables the /S-ON signal.
<ul style="list-style-type: none"> • After changing these parameters, turn OFF the main circuit and control power supplies and then turn them ON again to enable the new settings. • When the parameter is set to constantly “enable” the signal, resetting an alarm can only be done by turning the power OFF and ON. (Alarm reset is disabled.) 	

8.3.2 Switching the Servomotor Rotation Direction

The rotation direction of the servomotor can be switched without changing the reference pulse to the SERVOPACK or the reference voltage polarity.

This causes the travel direction (+, -) of the shaft reverse. The output signal polarity such as encoder pulse output and analog monitor signal from the SERVOPACK does not change.

The standard setting for “forward rotation” is counterclockwise as viewed from the drive end.

Parameter	Name	Reference		
		Forward Reference	Reverse Reference	
Pn000	n.□□□0	Standard setting (CCW = Forward) (Factory setting)		
	n.□□□1	Reverse Rotation Mode (CW = Reverse)		
The direction of P-OT and N-OT change. For Pn000 = n.□□□0 (standard setting), counterclockwise is P-OT. For Pn000 = n.□□□1 (Reverse Rotation Mode), clockwise is P-OT.				

8.3.3 Setting the Overtravel Limit Function

The overtravel limit function forces movable machine parts to stop if they exceed the allowable range of motion and turn ON a limit switch.

(1) Connecting the Overtravel Signal

To use the overtravel function, connect the following overtravel limit switch input signal terminals.

Type	Name	Connector Pin Number	Setting	Meaning
Input	P-OT	CN1-16 (Factory setting)	ON (low level)	Forward rotation allowed. Normal operation status.
			OFF (high level)	Forward rotation prohibited. Forward overtravel.
Input	N-OT	CN1-17 (Factory setting)	ON (low level)	Reverse rotation allowed. Normal operation status.
			OFF (high level)	Reverse rotation prohibited. Reverse overtravel.

Connect limit switches as shown below to prevent damage to the devices during linear motion.
Rotation in the opposite direction is possible during overtravel. For example, reverse rotation is possible during forward overtravel.

■ **IMPORTANT**
When the servomotor stops due to overtravel during position control, the position error pulses are held. A clear signal (/CLR) input is required to clear the error pulses.

⚠ CAUTION

When using the servomotor on a vertical axis, the workpiece may fall in the overtravel condition.
To prevent this, always set the zero clamp after stopping with Pn001 = n.□□1□.
Refer to 8.3.3 (3) *Selecting the Motor Stop Method When Overtravel is Used* in this section.

(2) Enabling/Disabling the Overtravel Signal

A parameter can be set to disable the overtravel signal. If the parameter is set, there is no need to wire the overtravel input signal.

Parameter	Meaning
Pn50A	n.2□□□ Inputs the Forward Run Prohibited (P-OT) signal from CN1-16. (Factory setting)
	n.8□□□ Disables the Forward Run Prohibited (P-OT) signal. (Allows constant forward rotation.)
Pn50B	n.□□□3 Inputs the Reverse Run Prohibited (N-OT) signal from CN1-17. (Factory setting)
	n.□□□8 Disables the Reverse Run Prohibited (N-OT) signal. (Allows constant reverse rotation.)

- Applicable control methods: Speed control, position control, and torque control
- After changing these parameters, turn OFF the main circuit and control power supplies and then turn them ON again to enable the new settings.

* A parameter can be used to re-allocate input connector number for the P-OT and N-OT signals. Refer to 7.3.2 *Input Circuit Signal Allocation*.

(3) Selecting the Motor Stop Method When Overtravel is Used

This is used to set the stop method when an overtravel (P-OT, N-OT) signal is input while the motor is operating.

Parameter	Stop Mode	Mode After Stopping	Meaning	
Pn001	n.□□00	Stop by dynamic brake	Coast	Rapidly stops the servomotor by dynamic braking (DB), then places it into Coast (power OFF) Mode.
	n.□□01			Coasts the servomotor to a stop, then places it into Coast (power OFF) Mode.
	n.□□02	Coast to a stop	Zero Clamp	Stops the servomotor in the same way as when the servo is OFF (coasts to a stop), then places it into Coast (power OFF) Mode.
	n.□□1□	Decelerate to stop		Decelerates the servomotor with emergency stop torque (Pn406), then places it into Zero Clamp (Servolock) Mode.
	n.□□2□			Coast

- During torque control, these settings affect only the servomotor stopping method. After it is stopped, the servomotor enters Coast Mode regardless of the setting.
- After changing these parameters, turn OFF the main circuit and control power supplies and then turn them ON again to enable the new settings.
- During n.□□02 Coast Mode, SERVOPACK can be resumed using the servo ON signal.

■ TERMS

- Stop by dynamic brake: Stops by using the dynamic brake (with short-circuiting by a circuit of SERVOPACK).
- Coast to a stop: Stops naturally, with no brake, by using the friction resistance of the motor in operation.
- Decelerate to stop: Stops by using deceleration (braking) torque.
- Zero Clamp Mode: A mode forms a position loop by using the position reference zero.

* For details on stopping methods when the servo turns OFF or when an alarm occurs, refer to 8.3.5 *Selecting the Stopping Method After Servo OFF*.

(4) Setting the Stop Torque for Overtravel

Pn406	Emergency Stop Torque			Speed	Position	Torque
	Setting Range	Setting Unit	Factory Setting	Setting Validation		
	0 to 800	%	800	Immediately		

- This sets the stop torque for when the overtravel signal (P-OT, N-OT) is input.
- The setting unit is a percentage of the rated torque (i.e., the rated torque is 100%).
- The value large enough to be the motor maximum torque, 800% is set as the factory setting for emergency stop torque. However, the actual output emergency stop torque is determined by motor ratings.

8.3.4 Setting for Holding Brakes

The holding brake is used when a SERVOPACK controls a vertical axis. In other words, a servomotor with brake prevents the movable part from shifting due to gravity when the SERVOPACK power goes OFF. (Refer to 8.1.4 *Servomotor with Brakes*.)

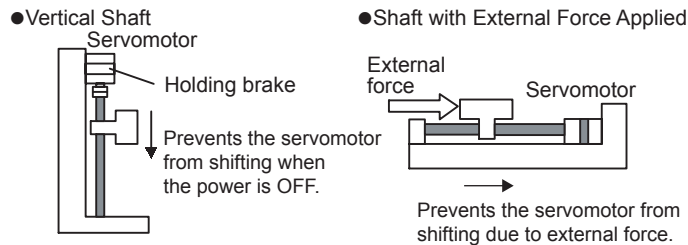

IMPORTANT

1. The brake built into the servomotor with brakes is a deenergization brake, which is used only to hold and cannot be used for braking. Use the holding brake only to hold a stopped motor. Brake torque is at least 120% of the rated motor torque.
2. When operating using only a speed loop, turn OFF the servo and set the input reference to 0 V when the brake is applied.
3. When forming a position loop, do not use a mechanical brake while the servomotor is stopped because the servomotor enters servolock status.

(1) Wiring Example

Use the SERVOPACK contact output signal /BK and the brake power supply to form a brake ON/OFF circuit. The following diagram shows a standard wiring example.

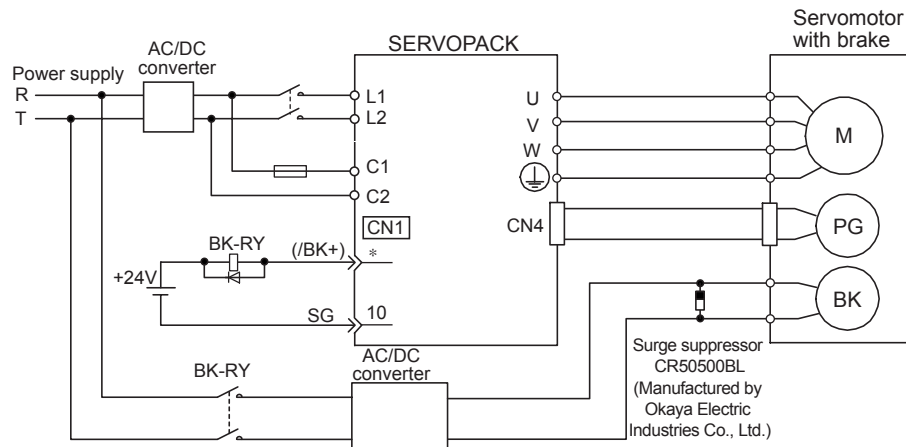

BK-RY: Brake control relay

AC/DC converter: The brakes of SGMMJ and SGMAJ SERVOPACK are 24 VDC.
The customer must provide the 24-VDC output power supply.

*1 and *2 are the output terminals allocated with Pn50F.2.

(2) Brake Interlock Output

Type	Name	Connector Pin Number	Setting	Meaning
Output	/BK	Must be allocated	ON (low level)	Releases the brake.
			OFF (high level)	Applies the brake.
<p>This output signal controls the brake and is used only for a servomotor with a brake. This output signal is not used with the factory settings. The output signal must be allocated (with Pn50F). It does not need to be connected for servomotors without a brake.</p> <p>■ IMPORTANT The /BK signal is not output during overtravel, or when there is no power to the servomotor.</p>				

(3) Allocating Brake Signals (/BK)

The brake signal (/BK) is not used with the factory settings. The output signal must be allocated.

Parameter	Connector Pin Number		Meaning	
	+ Terminal	- Terminal		
Pn50F	n.□0□□	–	–	The /BK signal is not used. (Factory setting)
	n.□1□□	CN1-8	CN1-10	The /BK signal is output from output terminal CN1-8, 10.
	n.□2□□	CN1-9	CN1-10	The /BK signal is output from output terminal CN1-9, 10.
	n.□3□□	CN1-7	CN1-10	The /BK signal is output from output terminal CN1-7, 10.
<p>■ IMPORTANT When set to the factory setting, the brake signal is invalid. When multiple signals are allocated to the same output terminal, the signals are output with OR logic. To output the /BK signal alone, disable the other output signals or set them to output terminals other than the one allocated to the /BK signal. For the allocation of SERVOPACK output signals other than /BK signal, refer to 7.3.3 <i>Output Circuit Signal Allocation</i>.</p>				

(4) Setting the Brake ON Timing after the Servomotor Stops

With the factory setting, the /BK signal is output at the same time as the servo is turned OFF. The servo OFF timing can be changed with a parameter.

Pn506	Delay Time from Brake Reference Until Servo OFF			<input type="checkbox"/> Speed	<input type="checkbox"/> Position	<input type="checkbox"/> Torque
	Setting Range	Setting Unit	Factory Setting	Setting Validation		
	0 to 50 (0 to 500 ms)	10 ms	0	Immediately		
<ul style="list-style-type: none"> When using the servomotor to control a vertical axis, the machine movable part may shift slightly depending on the brake ON timing due to gravity or an external force. By using this parameter to delay turning the servo OFF, this slight shift can be eliminated. This parameter changes the brake ON timing while the servomotor is stopped. For details on brake operation while the servomotor is operating, refer to 8.3.4 (5) <i>Setting the Brake ON Timing When Servomotor Running</i> in this section. 						
<p>■ IMPORTANT The servomotor will turn OFF immediately when an alarm occurs, regardless of the setting of this parameter. The machine movable part may shift due to gravity or external force during the time until the brake operates.</p>						

(5) Setting the Brake ON Timing When Servomotor Running

The following parameters can be used to change the /BK signal output conditions when a stop reference is output during servomotor operation due to the servo OFF or an alarm occurring.

Pn507	Brake Reference Output Speed Level			Speed	Position	Torque
	Setting Range	Setting Unit	Factory Setting	Setting Validation		
	0 to 10000	min ⁻¹	100	Immediately		
Pn508	Timing for Brake Reference Output during Motor Operation			Speed	Position	Torque
	Setting Range	Setting Unit	Factory Setting	Setting Validation		
	10 to 100 (100 to 1000 ms)	10 ms	50 (500 ms)	Immediately		
/BK Signal Output Conditions When Servomotor Running The /BK signal goes to high level (brake ON) when either of the following conditions is satisfied: <ul style="list-style-type: none"> • When the motor speed falls below the level set in Pn507 after the servo OFF. • When the time set in Pn508 is exceeded after the servo OFF. 						
<p>The diagram illustrates the timing of the /BK signal output. It shows three signals: /S-ON input, Motor speed, and /BK output. The /S-ON input transitions from 'Servo ON' to 'Servo OFF'. Upon 'Servo OFF', the motor speed begins to decay. The /BK output transitions from 'Brake released' to 'Brake held'. The time delay between 'Servo OFF' and 'Brake held' is labeled as Pn508. The speed threshold at which the brake is held is labeled as Pn507. A note indicates that the motor is stopped by applying DB or by coasting (Pn001.0).</p>						
■ IMPORTANT <ul style="list-style-type: none"> • The servomotor will be limited to its maximum speed even if the value set in Pn507 is higher than the maximum speed. • Allocate the running output signal (/TGON) and the brake signal (/BK) to different terminals. • If the brake signal (/BK) and running output signal (/TGON) are allocated to the same output terminal, the /TGON signal will go to low level at the speed at which the movable part drops on the vertical axis, which means that the /BK signal will not go to high level even if the conditions of this parameter are met. (This is because signals are output with OR logic when multiple signals are allocated to the same output terminal.) For output signal allocations, refer to 7.3.3 <i>Output Circuit Signal Allocation</i>. 						

8.3.5 Selecting the Stopping Method After Servo OFF

The stopping method when the power to the SERVOPACK turns OFF can be selected.

Parameter	Stop Mode	Mode After Stopping	Meaning
Pn001	n.□□□0	Stop by dynamic brake	Dynamic Brake Stops the servomotor by dynamic braking (DB), then holds it in Dynamic Brake Mode. (Factory setting)
	n.□□□1		Coast Stops the servomotor by dynamic braking (DB), then places it into Coast (power OFF) Mode.
	n.□□□2	Coast to a stop	Coast Stops the servomotor by coasting, then places it into Coast (power OFF) Mode.

These parameters are valid under the following conditions:

- When the /S-ON input signal is OFF (Servo OFF).
- When an alarm occurs.
- When main circuit power supply (L1, L2) is OFF.

Similar to the Coast Mode, the n.□□□0 setting (which stops the servomotor by dynamic braking and then holds it in Dynamic Brake Mode) does not generate any braking force when the servomotor stops or when it rotates at very low speed.

■ TERMS

- Stop by dynamic brake: Stops by using the dynamic brake (with short-circuiting by a circuit of SERVOPACK).
- Coast to a stop: Stops naturally, with no brake, by using the friction resistance of the motor in operation.

■ IMPORTANT

The SERVOPACK is **forced to stop by dynamic braking, regardless of the settings of this parameter**, when the control power supply (C1, C2) turns OFF.

If the servomotor must be stopped by coasting rather than by dynamic braking when the control power supply (C1, C2) turns OFF, arrange the sequence externally so the servomotor wiring (U, V, W) will be interrupted.

IMPORTANT

The dynamic brake (DB) is an emergency stop function.

If the servomotor is frequently started and stopped by turning the power ON/OFF or using the servo ON signal (/S-ON), the DB circuit will also be repeatedly operated, degrading the SERVOPACK's internal elements. Use the speed input reference and position reference to control the starting and stopping of the servomotor.

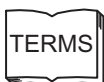

Dynamic brake (DB)

A common method for quickly stopping a servomotor. The servomotor is stopped by short-circuiting the servomotor circuit. This circuit is built into the SERVOPACK.

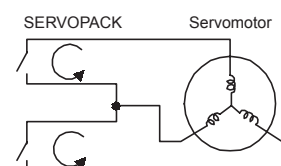

8.3.6 Instantaneous Power Loss Settings

Determines whether to continue operation or turn the servo OFF when the power supply voltage to the SERVOPACK main circuit is instantaneously interrupted.

Pn509	Instantaneous Power Cut Hold Time				
			Speed	Position	Torque
	Setting Range	Setting Unit	Factory Setting	Setting Validation	
	20 to 1000	ms	20	Immediately	

In power loss detection, the status of the main circuit power supply is detected and OFF status is ignored so servomotor operation will continue if the servomotor turns back ON within the time set in parameter Pn509.

In the following instances, however, the parameter setting will be invalid.

- If an insufficient voltage alarm (A.41) occurs during a power loss with a large servomotor load.
- When control is lost (equivalent to normal power OFF operation) with loss of the control power supply.

■ **IMPORTANT**
The maximum setting for the hold time during a power loss is 1,000 ms, but the hold time for the SERVOPACK control power supply is about 100 ms. The hold time for the main circuit power supply depends on the SERVOPACK output.

To continue SERVOPACK operation for a power loss that is longer than this, provide an uninterruptible power supply.

The diagram illustrates the servo's response to an instantaneous power interruption. The top trace shows the power supply voltage dropping to zero for a duration 't' (OFF time) and then recovering. The middle trace shows the servo's state when Pn509 > t: the servo remains ON during the power loss, and operation continues after the power returns. The bottom trace shows the servo's state when Pn509 < t: the servo turns OFF during the power loss and remains OFF until the power returns.

8.4 Absolute Encoders

WARNING

- The output range of multiturn data for the Σ -II series absolute detection system differs from that for conventional systems (15-bit encoder and 12-bit encoder). When an infinite length positioning system of the conventional type is to be configured with the Σ -II series, be sure to make the following system modification.

If a motor with an absolute encoder is used, a system to detect the absolute position can be made in the host controller. Consequently, operation can be performed without zero point return operation immediately after the power is turned ON.

SGMAJ-□□□1□ servomotor: With 16-bit absolute encoder

SGMMJ-□□□2□ servomotor: With 17-bit absolute encoder

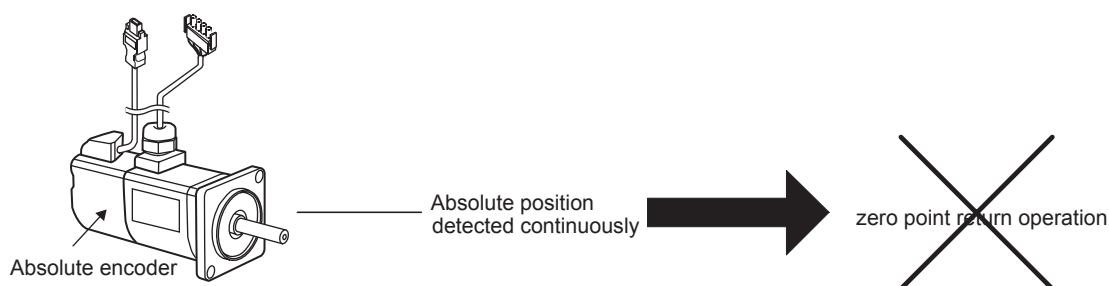

Absolute Encoder Type	Resolution	Output Range of Multiturn Data	Action when Limit Is Exceeded
Σ Series SGD SGDA SGDB	12-bit 15-bit	-99999 to + 99999	<ul style="list-style-type: none"> When the upper limit (+99999) is exceeded in the forward direction, the multiturn data is 0. When the lower limit (-99999) is exceeded in the reverse direction, the multiturn data is 0.
Σ -II Series SGDJ SGDM SGDH SGDP	16-bit 17-bit	-32768 to + 32767	<ul style="list-style-type: none"> When the upper limit (+32767) is exceeded in the forward direction, the multiturn data is -32768.* When the lower limit (-32767) is exceeded in the reverse direction, the multiturn data is +32768.*

* The action differs when the Multiturn Limit Setting (Pn205) is changed. Refer to 8.4.7 *Multiturn Limit Setting*.

8.4.1 Interface Circuits

The following diagram shows the standard connections for a an absolute encoder mounted to a servomotor. The connection cables and wiring pin numbers depend on the servomotor. For details, refer to *chapter 5 Specifications and Dimensional Drawings of Cables and Peripheral Devices*.

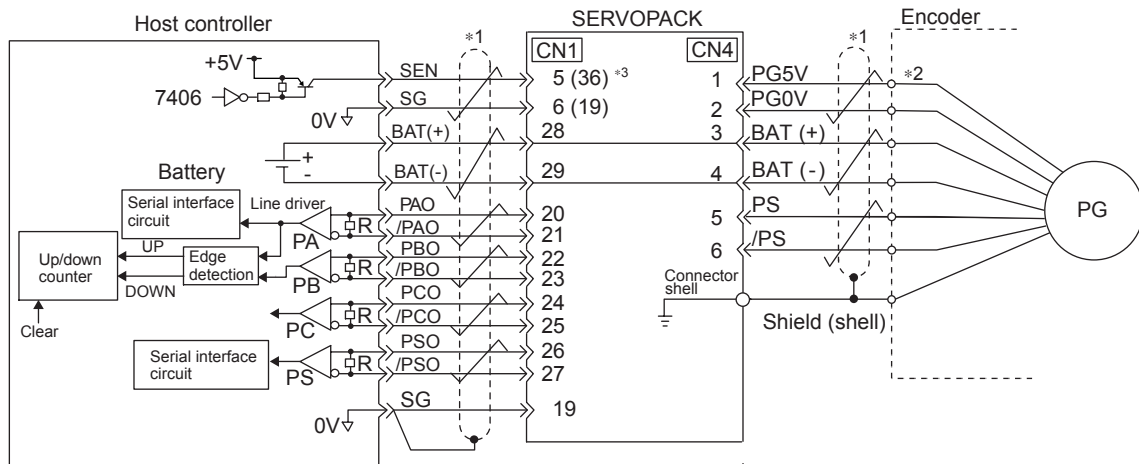

Applicable line driver:
Texas Instruments's SN75175 or KM3486
Terminating resistance R: 220 to 470 Ω

- *1. : Represents twisted-pair wires.
- *2. For wiring pin numbers, refer to *chapter 5 Specifications and Dimensional Drawings of Cables and Peripheral Devices*
- *3. () : Represents the pin number for SGDJ-□□□P position control type.

• SEN Signal Connection

Type	Name	Connector Pin Number	Setting	Meaning	
Input	SEN	□□□-S	CN1-5	OFF (low level)	Input when power is turned ON
		□□□-P	CN1-36	ON (high level)	Input at absolute data request

This input signal is required to output absolute data from the SERVOPACK.
Let at least three seconds elapse after turning ON the power before changing the SEN signal to high level. When the SEN signal changes from low level to high level, the multiturn data and initial incremental pulses are output.
Until these operations have been completed, the servomotor cannot be turned ON regardless of the status of the servo ON signal (/S-ON). The panel operator display will also remain “b.b.”
Refer to 8.4.6 Absolute Encoder Reception Sequence.

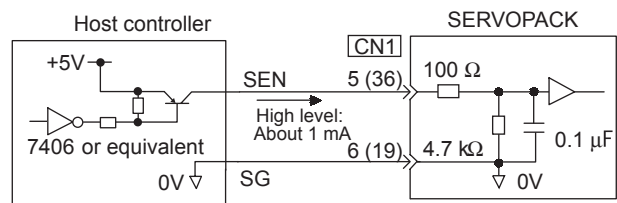

We recommend a PNP transistor.
Signal levels
High: 4.0 V min., Low: 0.8 V max.

■ IMPORTANT

Maintain the high level for at least 1.3 seconds when the SEN signal is turned OFF and then ON, as shown in the figure on the right.

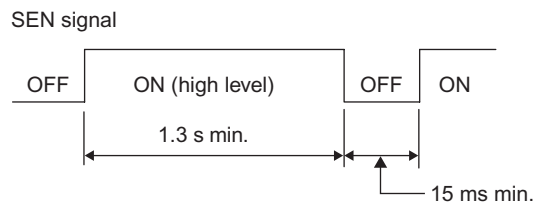

8.4.2 Selecting an Absolute Encoder

An absolute encoder can also be used as an incremental encoder.

Parameter	Meaning
Pn002 n.□0□□	Use the absolute encoder as an absolute encoder. (Factory setting)
n.□1□□	Use the absolute encoder as an incremental encoder.
<ul style="list-style-type: none"> • The SEN signal and back-up battery are not required when using the absolute encoder as an incremental encoder. • After changing these parameters, turn OFF the main circuit and control power supplies and then turn them ON again to enable the new settings. 	

8.4.3 Handling Batteries

In order for the absolute encoder to retain position data when the power is turned OFF, the data must be backed up by a battery.

 PROHIBITED
<ul style="list-style-type: none"> • Install the battery at either the host controller or the SERVOPACK end. It is dangerous to install batteries at both simultaneously, because that sets up a loop circuit between the batteries.

Battery Installation Location	Yaskawa Model*	Manufacturer Model	Specifications	Manufacturer
Host controller	—	ER6VC3	Lithium battery 3.6 V 2000mAh	Toshiba Battery Co., Ltd.

Prepare the battery according to the specifications of the host controller. Use the battery with the model number ER6VC3 (3.6 V, 2000 mAh made by Toshiba Battery Co., Ltd.) or equivalent

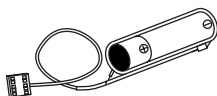

8.4.4 Replacing Batteries

The SERVOPACK will generate an absolute encoder battery alarm (A.83) when the battery voltage drops below about 2.7 V. This alarm is output, however, only when the SERVOPACK power is turned ON. If the voltage drops while the SERVOPACK power is ON, the SERVOPACK will not generate the alarm.

This alarm can be changed to an absolute encoder battery warning (A.93) by setting the parameter.

• Battery Replacement Procedure

1. Replace the battery with only the SERVOPACK control power supply turned ON.
2. After replacing the battery, turn OFF the SERVOPACK power to cancel the absolute encoder battery alarm (A.83).
3. Turn ON the SERVOPACK power back again. If it operates without any problems, the battery replacement has been completed.

IMPORTANT

If the SERVOPACK control power supply is turned OFF and the battery is disconnected (which includes disconnecting the encoder cable), **the absolute encoder data will be deleted**. The absolute encoder must be setup again. Refer to 8.4.5 *Absolute Encoder Setup (Fn008)*.

8.4.5 Absolute Encoder Setup (Fn008)

Setting up (initializing) the absolute encoder is necessary in the following cases.











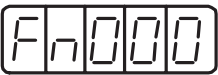

- When starting the machine for the first time
- When an encoder backup error alarm (A.81) is generated
- When an encoder checksum error alarm (A.82) is generated
- To set the absolute encoder multiturn data to 0

Use a built-in type digital operator in the SERVOPACK or a digital operator for setup.

IMPORTANT

1. Encoder setup operation is only possible when the servo is OFF.
2. If the following absolute encoder alarms are displayed, cancel the alarm by using the same method as the setup (initializing). They cannot be canceled with the SERVOPACK alarm reset input signal (/ALM-RST).
 - Encoder backup error alarm (A.81)
 - Encoder checksum error alarm (A.82)

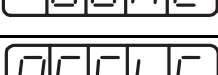
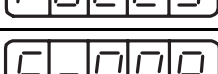
Any other alarms that monitor the inside of the encoder should be canceled by turning OFF the power.

Step	Display after Operation	Key	Description
1	Alarm generated		
2		 (DSPL/SET Key)	Press the DSPL/SET Key to select the utility function mode.
3			Press the UP or DOWN Key to select parameter Fn008. Note: The digit that can be set will blink.
4		 (DATA/ENTER Key)	Press the DATA/ENTER Key. The display will be as shown at the left.
5			Continue pressing the UP Key until PGCL5 is displayed. Note: If there is a mistake in the key operation, “nO_OP” will blink for about one second. The panel operator or digital operator will return to the utility function mode.
6		 (DSPL/SET Key)	Press the DSPL/SET Key. This will clear the multiturn data of the absolute encoder. When completed, “donE” will blink for about one second.
7		About one second later	After “donE” is displayed, “PGCL5” will be displayed again.
8		 (DATA/ENTER Key)	Press the DATA/ENTER Key to return to the Fn008 display of the utility function mode.
9	Turn OFF the power, and then turn it ON again to make the setting valid.		

8.4.6 Absolute Encoder Reception Sequence

The sequence in which the SERVOPACK receives outputs from the absolute encoder and transmits them to host controller is shown below.

(1) Outline of Absolute Signals

The serial data, pulses, etc., of the absolute encoder that are output from the SERVOPACK are output from the PAO, PBO, and PCO signals as shown below.

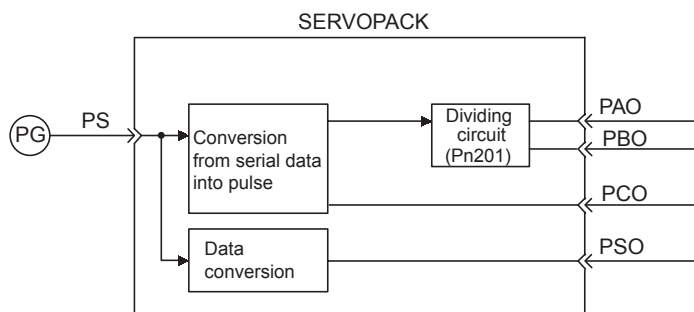

Signal Name	Status	Meaning
PAO	At initial status	Serial data Initial incremental pulse
	At normal status	Incremental pulse
PBO	At initial status	Initial incremental pulse
	At normal status	Incremental pulse
PCO	Always	Zero point pulse
PSO	Always	Rotation count serial data

(2) Absolute Encoder Transmission Sequence and Contents

1. Set the SEN signal at high level.
2. After 100 ms, set the system to serial data reception-waiting-state. Clear the incremental pulse up/down counter to zero.
3. Receive eight bytes of serial data.
4. The system enters a normal incremental operation state about 400 ms after the last serial data is received.

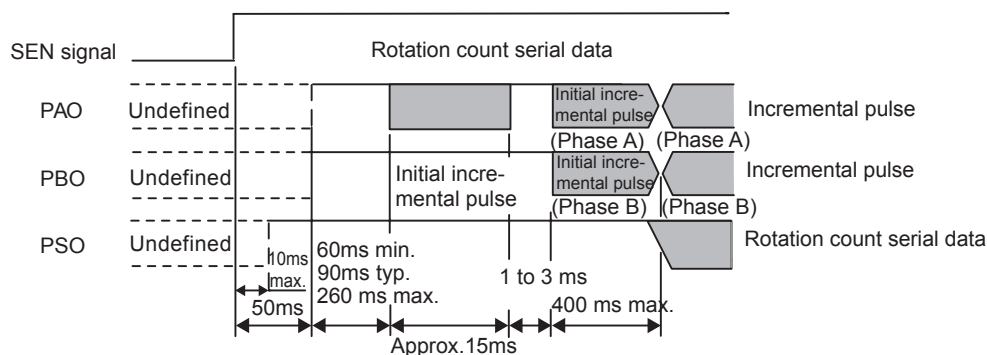

- Serial data: Indicates how many turns the motor shaft has made from the reference position (position specified at setup).
- Initial incremental pulse: Outputs pulses at the same pulse rate as when the motor shaft rotates from the origin to the current position at about 2500 min^{-1} (for 16 bits when the dividing pulse is at the factory setting).

8.4.6 Absolute Encoder Reception Sequence

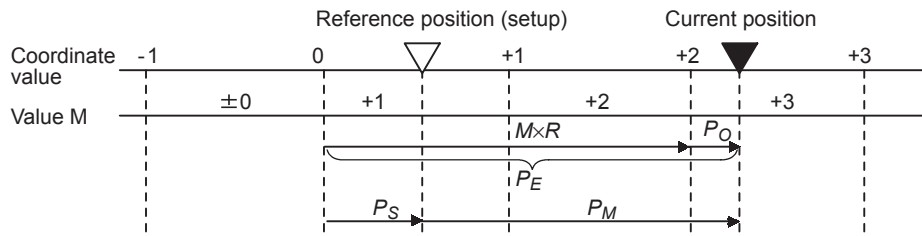

Final absolute data P_M is calculated by following formula.

$$P_E = M \times R + P_O$$

$$P_M = P_E - P_S$$

Use the following for reverse rotation mode (Pn000.0 = 1).

$$P_E = -M \times R + P_O$$

$$P_M = P_E - P_S$$

P_E	Current value read by encoder
M	Multiturn data (rotation count data)
P_O	Number of initial incremental pulses
P_S	Number of initial incremental pulses read at setup (This is saved and controlled by the host controller.)
P_M	Current value required for the user's system
R	Number of pulses per encoder revolution (pulse count after dividing, value of Pn201)

(3) Detailed Signal Specifications

(a) PAO Serial Data Specifications

The number of revolutions is output in five digits.

Data Transfer Method	Start-stop Synchronization (ASYNC)
Baud rate	9600 bps
Start bits	1 bit
Stop bits	1 bit
Parity	Even
Character code	ASCII 7-bit code
Data format	8 characters, as shown below.

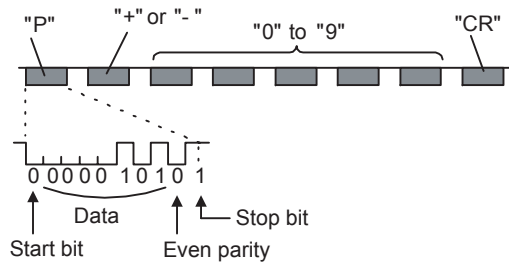

- Note: 1. Data is “P+00000” (CR) or “P-00000” (CR) when the number of revolutions is zero.
 2. The revolution range is “+32767” to “-32768.” When this range is exceeded, the data changes from “+32767” to “-32678” or from “-32678” to “+32767.” When changing multiturn limit, the range changes. For details, refer to 8.4.7 *Multiturn Limit Setting*.

(b) PSO Serial Data Specifications

The number of revolutions is always output in five digits and seven digits (absolute position within one revolution).

Data Transfer Method	Start-stop Synchronization (ASYNC)
Baud rate	9600 bps
Start bits	1 bit
Stop bits	1 bit
Parity	Even
Character code	ASCII 7-bit code
Data format	13 characters, as shown below.

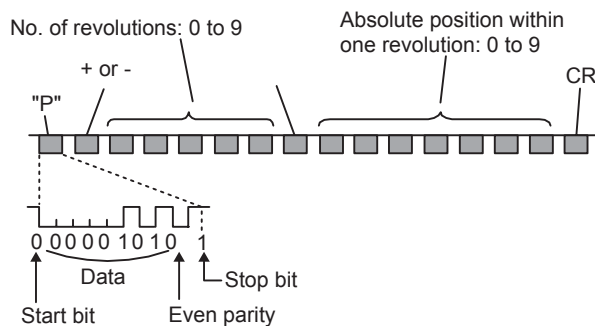

- Note: 1. The absolute position data within one revolution is the value before divided.
 2. The absolute position data increases during forward rotation. (The reverse rotation mode is invalid.)

(c) Incremental Pulses and Zero-Point Pulses

Just as with normal incremental pulses, initial incremental pulses which provide absolute data are first divided by the frequency divider inside the SERVOPACK and then output.

For details, refer to 8.5.7 Encoder Signal Output.

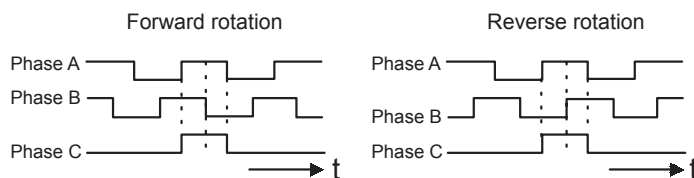

(4) Transferring Alarm Contents

When an absolute encoder is used, SEN signals can be utilized to transfer the alarm detection contents from PAO outputs to the host controller as serial data.

For alarm list, refer to *10.1.1 Alarm Display Table*.

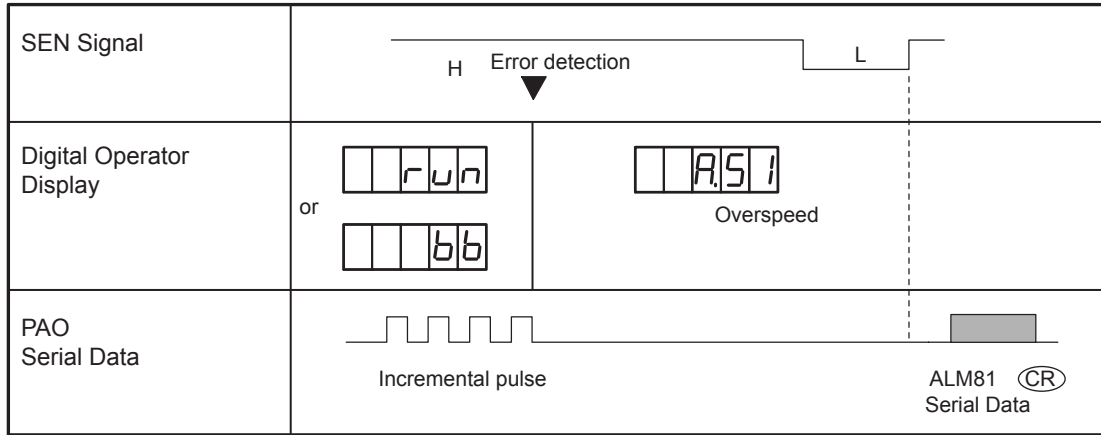

8.4.7 Multiturn Limit Setting

⚠ WARNING

- The multiturn limit value must be changed only for special applications. Changing it inappropriately or unintentionally can be dangerous.
- If the Multiturn Limit Disagreement alarm (A.CC) occurs, check the setting of parameter Pn205 to be sure that it is correct.
If Fn013 is executed when an incorrect value is set in Pn205, an incorrect value will be set in the encoder. The alarm will disappear even if an incorrect value is set, but incorrect positions will be detected, resulting a dangerous situation where the machine will move to unexpected positions and machine break and personal accident will occur.

The parameter for the multiturn limit setting sets the upper limit for the multiturn data from the encoder into Pn002 = n□0□□ when using an absolute encoder. When the rotation amount exceeds this setting, the encoder rotation amount returns to 0.

Pn205	Multiturn Limit Setting		
	Setting Range	Setting Unit	Factory Setting
	0 to 65535	Rev	65535
		Speed	Position
		Torque	
Setting Validation			
After restart			

This parameter is valid when Pn002 = n□0□□ (when the absolute encoder is used).
The range of the multiturn data will vary when this parameter is set to anything other than the factory setting.

Factory Setting (=65535)

Without Factory Setting (≠65535)

■ **When Set to Anything Other than the Factory Setting (≠65535)**

When the motor rotates in the reverse direction with the multiturn data at 0, the multiturn data will change to the setting of Pn205.
When the motor rotates in the forward direction with the multiturn data at the Pn205 setting, the multiturn data will change to 0.
Set the Pn205 to (the desired multiturn data -1).

Position detection

(Revolution counter)

Detection amount

(Absolute encoder)

Position

Travel distance/motor = 1 revolution

• Encoder Multiturn Limit Disagreement

If the Pn205 value is changed from the factory setting and the power is turned OFF then ON, an alarm will be displayed.

Alarm Display	Alarm Name	Alarm Code Outputs			Meaning
A.CC	Multiturn Limit Disagreement	ALO1	ALO2	ALO3	Different multiturn limits have been set in the encoder and SERVOPACK.
		ON (L)	OFF (H)	ON (L)	

8.4.8 Multiturn Limit Setting When Multiturn Limit Disagreement (A.CC) Occurred

Perform the following operation using the digital operator.

This operation can only be done when the A.CC alarm is generated.

Step	Display after Operation	Key	Description
1		 (DSPL/SET Key)	Press the DSPL/SET Key to select the utility function mode.
2		 	Press the LEFT/RIGHT or UP/DOWN Key or the UP or DOWN Key to set the parameter Fn013. *The digit that can be set will blink.
3		 (DATA/ENTER Key)	Press the DATA/ENTER Key. The display on the left will appear.
4		 (DSPL/SET Key)	Press the DSPL/SET Key. The multiturn limit setting in the absolute encoder will be changed. When the setting is completed, "donE" will blink for about one second.
5		About one second later	After "donE" is displayed, "PGSEt" will be displayed again.
6		 (DATA/ENTER Key)	Press the DATA/ENTER Key to return to the Fn013 display of the utility function mode.
7	Turn OFF the power, and then turn it ON again to make the setting valid.		

8.5 Operating Using Speed Control with Analog Reference



8.5.1 Setting Parameters

Parameter	Description
Pn000 n.□□0□	Control mode selection: Speed control (analog reference) (factory setting)

Pn300	Speed Reference Input Gain			
	Setting Range	Setting Unit	Factory Setting	Setting Validation
	1.50 to 3000 (150 to 30.00 V/Rated speed)	0.01 V/Rated speed	600	Immediately
Sets the analog voltage level for the speed reference (V-REF) necessary to operate the servomotor at the rated speed.				
■ EXAMPLE Pn300=600: 6-V input is equivalent to the rated speed of the servomotor (factory setting). Pn300=1000: 10-V input is equivalent to the rated speed of the servomotor. Pn300=200: 2-V input is equivalent to the rated speed of the servomotor.				

8.5.2 Setting Input Signals

(1) Speed Reference Input

Input the speed reference to the SERVOPACK using the analog voltage reference to control the servomotor speed in proportion to the input voltage.

Type	Signal Name	Connector Pin Number	Name
Input	V-REF	CN1-3	Speed Reference Input
	SG	CN1-4	Signal Ground for Speed Reference Input

The above inputs are used for speed control (analog voltage reference). (Pn000.1 = 0, 4, 9, or A)
Pn300 is used to set the speed reference input gain. Refer to 8.5.1 *Setting Parameters*.

■ Input Specifications

- Input range: ± 2 VDC to ± 10 VDC/rated speed
- Maximum allowable input voltage: ± 12 VDC

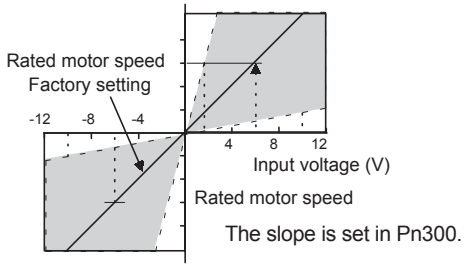

Rated motor speed
Factory setting

Rated motor speed

The slope is set in Pn300.

• Setting Example

Pn300 = 600: Rated speed at ± 6 V
Actual examples are shown below.

Speed Reference Input	Rotation Direction	Motor Speed	SGMAH Servomotor
+6 V	Forward	Rated motor speed	3000 min ⁻¹
+1 V	Forward	(1/6) rated motor speed	500 min ⁻¹
-3 V	Reverse	(1/2) rated motor speed	1500 min ⁻¹

Parameter Pn300 can be used to change the voltage input range.

■ Input Circuit Example

- Always use twisted-pair wire to control noise.
- Recommended variable resistor: Model 25HP-10B manufactured by Sakae Tsushin Kogyo Co., Ltd.

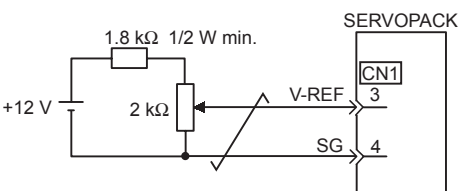

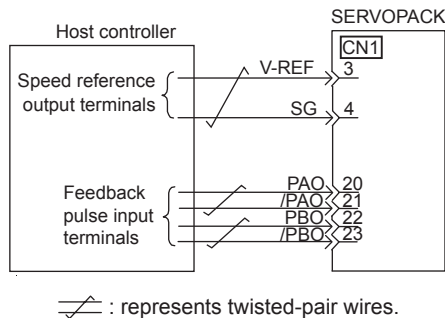

⚡ : represents twisted-pair wires.

(2) Proportional Control Reference (/P-CON)

Type	Signal Name	Connector Pin Number	Setting	Description
Input	/P-CON	CN1-15	ON (low level)	Operates the SERVOPACK with proportional control.
			OFF (high level)	Operates the SERVOPACK with proportional integral control.

/P-CON signal selects either the PI (proportional integral) or P (proportional) Speed Control Mode.
Switching to P control reduces servomotor rotation and minute vibrations due to speed reference input drift.
Input reference: At 0 V, the servomotor rotation due to drift will be reduced, but servomotor rigidity (holding force) drops when the servomotor is stopped.
Note: A parameter can be used to reallocate the input connector number for the /P-CON signal. Refer to 7.3.2 *Input Circuit Signal Allocation*.

8.5.3 Adjusting Offset

When using the speed control, the servomotor may rotate slowly even if 0 V is specified as the analog voltage reference. This happens if the host controller or external circuit has a slight offset (in the units of mV) in the reference voltage. Adjustments can be done manually or automatically by using the digital operator. Refer to 7.2 *Operation in Utility Function Mode (Fn□□□)*.

The automatic adjustment of the analog (speed, torque) reference offset (Fn009) automatically measures the amount of the offset and adjusts the reference voltage.

The SERVOPACK automatically adjusts the offset when the host controller or external circuit has the offset in the reference voltage.

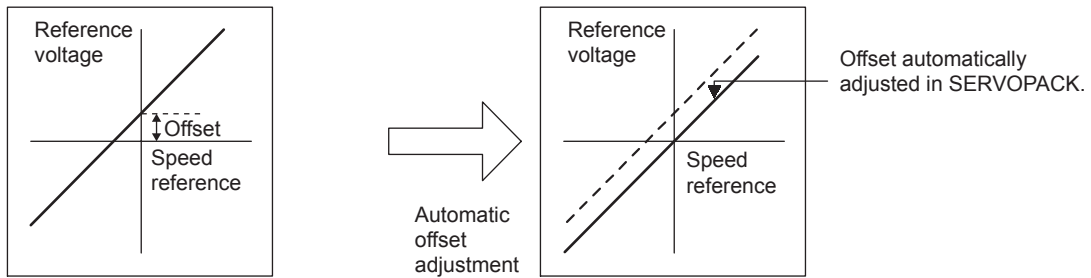

After completion of the automatic adjustment, the amount of offset is stored in the SERVOPACK. The amount of offset can be checked in the speed reference offset manual adjustment mode (Fn00A). Refer to 8.5.3 (2) *Manual Adjustment of the Speed Reference Offset*.

(1) Automatic Adjustment of the Speed Reference Offset

The automatic adjustment of reference offset (Fn009) cannot be used when a position loop has been formed with a host controller and the error pulse is changed to zero at the servomotor stop due to servolock. Use the speed reference offset manual adjustment (Fn00A) described in the next section for a position loop.

The zero-clamp speed control function can be used to force the motor to stop while the zero speed reference is given. Refer to *8.5.6 Using the Zero Clamp Function*.

IMPORTANT

The speed reference offset must be automatically adjusted with the servo OFF.

Adjust the speed reference offset automatically in the following procedure.

Step	Display after Operation	Key	Description
1			Turn OFF the SERVOPACK, and input the 0-V reference voltage from the host controller or external circuit.
2		 (DSPL/SET Key)	Press the DSPL/SET Key to select the utility function mode.
3		 	Press the LEFT/RIGHT or UP/DOWN Key, or UP or DOWN Key to select parameter Fn009. *The digit that can be set will blink.
4		 (DATA/ENTER Key)	Press the DATA/ENTER Key. “rEF_o” will be displayed.
5		 (DSPL/SET Key)	Press the DSPL/SET Key. The reference offset will be automatically adjusted. When completed, “donE” will blink for about one second.
6		About one second later	After “donE” is displayed, “rEF_o” will be displayed again.
7		 (DATA/ENTER Key)	Press the DATA/ENTER Key to return to the Fn009 display of the utility function mode.

(2) Manual Adjustment of the Speed Reference Offset

Use the speed reference offset manual adjustment (Fn00A) in the following situations:

- If a loop is formed with the host controller and the position error pulse is to be zero when servolock is stopped.
- To deliberately set the offset to some value.
- To check the offset data set in the speed reference offset automatic adjustment mode.

This function operates in the same way as the reference offset automatic adjustment mode (Fn009), except that the amount of offset is directly input during the adjustment.

The offset setting range and setting units are as follows:

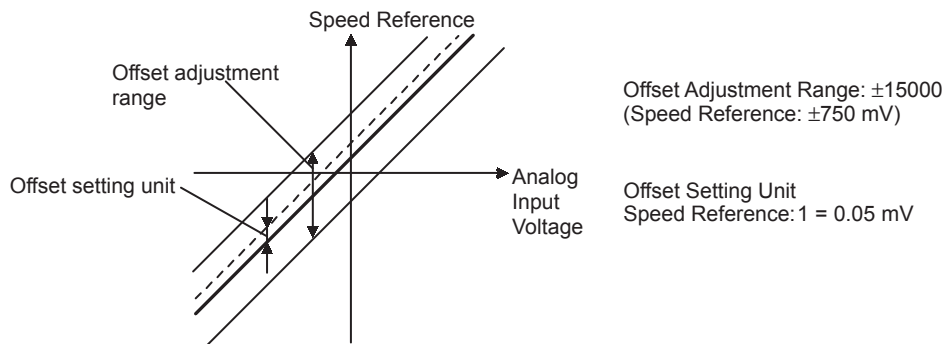

Adjust the speed reference offset manually in the following procedure.

Step	Display after Operation	Key	Description
1		 (DSPL/SET Key)	Press the DSPL/SET Key to select the utility function mode.
2			Press the UP or DOWN Key to select parameter Fn00A. *The digit that can be set will blink.
3		 (DATA/ENTER Key)	Press the DATA/ENTER Key. The display will be as shown at the left. The manual adjustment mode for the speed reference offset will be entered.
4		Servo ON	Turn ON the servo ON (/S-ON) signal. The display will be as shown at the left.
5			Press the LEFT or RIGHT Key to display the speed reference offset amount.
6			Press the UP or DOWN Key to adjust the amount of offset.
7			Press the LEFT or RIGHT Key. The display will appear momentarily as shown at the left, and "donE" will blink and the offset will be set. After the setting is completed, the display will return to the display as shown at the left.
8		 (DATA/ENTER Key)	Press the DATA/ENTER Key to return to the Fn00A display of the utility function mode.

8.5.4 Soft Start

The soft start function converts the stepwise speed reference inside the SERVOPACK to a consistent rate of acceleration and deceleration.

Pn305	Soft Start Acceleration Time Speed			
	Setting Range	Setting Unit	Factory Setting	Setting Validation
	0 to 10000	ms	0	Immediately
Pn306	Soft Start Deceleration Time Speed			
	Setting Range	Setting Unit	Factory Setting	Setting Validation
	0 to 10000	ms	0	Immediately
<p>The soft start function enables smooth speed control when inputting a stepwise speed reference or when selecting internally set speeds. Set both Pn305 and Pn306 to “0” for normal speed control.</p> <p>Set these parameters as follows:</p> <ul style="list-style-type: none"> • Pn305: The time interval from the time the motor starts until the motor maximum speed is reached. • Pn306: The time interval from the time the motor is operating at the motor maximum speed until it stops. 				

8.5.5 Speed Reference Filter

Pn307	Speed Reference Filter Time Constant Speed			
	Setting Range	Setting Unit	Factory Setting	Setting Validation
	0 to 65535 (0 to 655.35 ms)	0.01 ms	40 (0.40 ms)	Immediately
<p>This smoothens the speed reference by applying a 1st-order delay filter to the analog speed reference (V-REF) input. A value that is too large, however, will slow down response.</p>				

8.5.6 Using the Zero Clamp Function

(1) Zero Clamp Function

The zero clamp function is used for systems where the host controller does not form a position loop for the speed reference input. When the zero clamp signal (/ZCLAMP) is ON, a position loop is formed inside the SERVOPACK as soon as the input voltage of the speed reference (V-REF) drops below the motor speed level in the zero clamp level (Pn501). The servomotor ignores the speed reference and then quickly stops and locks the servomotor.

The servomotor is clamped within ± 1 pulse of when the zero clamp function is turned ON, and will still return to the zero clamp position even if it is forcibly rotated by external force.

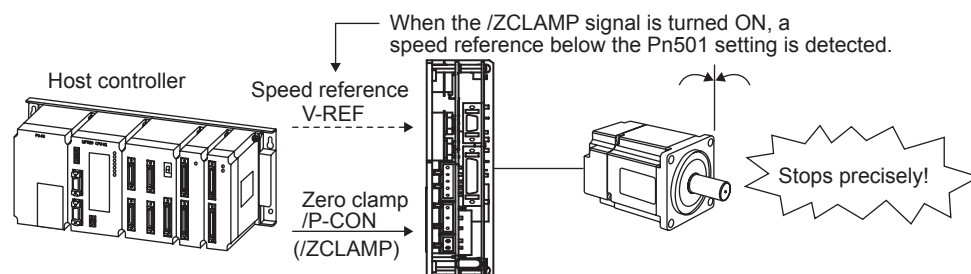

(2) Parameter Setting

Parameter	Meaning
Pn000 n.□□A□	Control mode selection: Speed control (analog voltage reference) ↔ Zero clamp
<p>Zero Clamp Conditions Zero clamp is performed with Pn000 = n.□□A□ when the following two conditions are satisfied:</p> <ul style="list-style-type: none"> • /P-CON (/ZCLAMP) is ON (low level). • Speed reference (V-REF) drops below the setting of Pn501. 	

Pn501	Zero Clamp Level	Speed		
	Setting Range	Setting Unit	Factory Setting	Setting Validation
	0 to 10000	min ⁻¹	10	Immediately
Sets the motor speed at which the zero clamp is performed if zero clamp speed control (Pn000 = n.□□A□) is selected. Even if this value is set higher than the maximum speed of the servomotor, the maximum speed will be used.				

(3) Input Signal Setting

Type	Signal Name	Connector Pin Number	Setting	Meaning
Input	/P-CON	CN1-15	ON (low level)	Zero clamp function ON (enabled)
			OFF (high level)	Zero clamp function OFF (disabled)
	/ZCLAMP	Must be allocated	ON (low level)	Zero clamp function ON (enabled)
			OFF (high level)	Zero clamp function OFF (disabled)
This is the input signal for the zero clamp operation. Either /P-CON or /ZCLAMP can be used to switch the zero clamp. To use the /ZCLAMP signal, an input signal must be allocated. Refer to 7.3.2 <i>Input Circuit Signal Allocation</i> for more details.				
<p>■ IMPORTANT When the /ZCLAMP signal is allocated, the zero clamp operation will be used even for speed control Pn000 = n.□□0□.</p>				

8.5.7 Encoder Signal Output

Encoder feedback pulses processed inside the SERVOPACK can be output externally.

Type	Signal Name	Connector Pin Number	Name
Output	PAO	CN1-20	Encoder output phase A
	/PAO	CN1-21	Encoder output phase /A
Output	PBO	CN1-22	Encoder output phase B
	/PBO	CN1-23	Encoder output phase /B
Output	PCO	CN1-24	Encoder output phase C (zero-point pulse)
	/PCO	CN1-25	Encoder output phase /C (zero-point pulse)

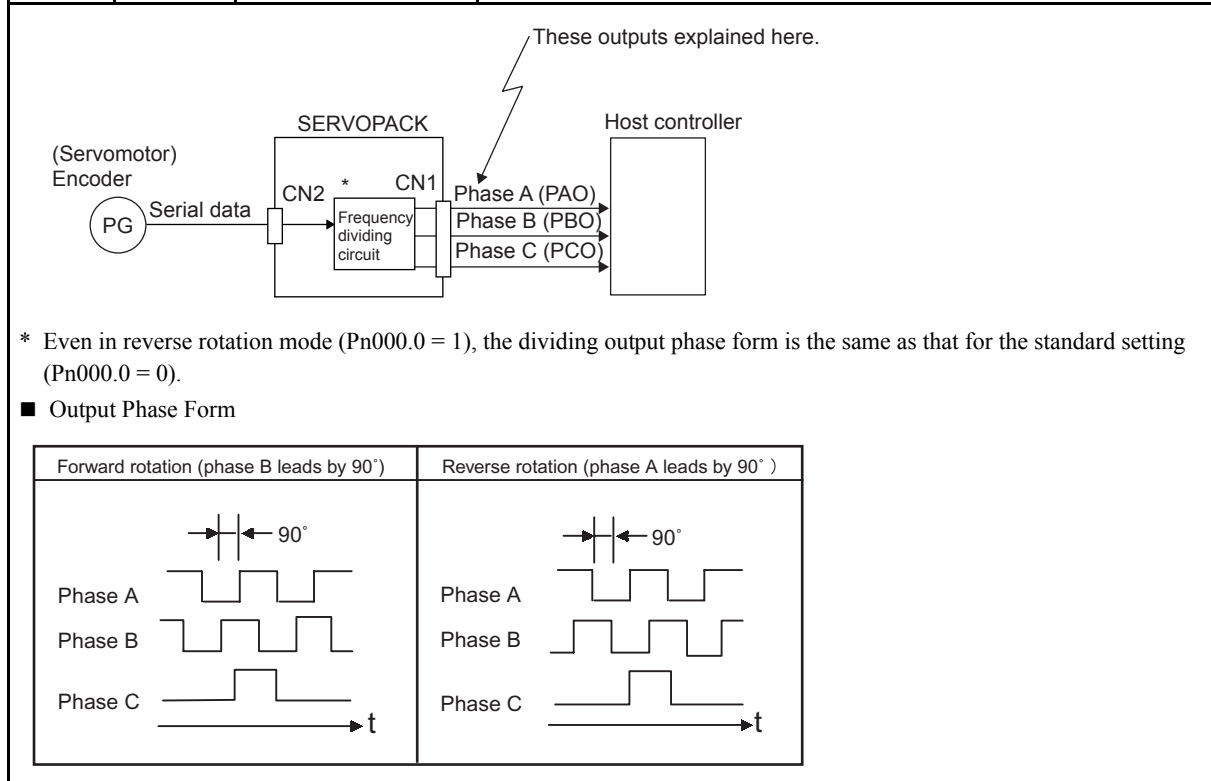

The following signals are added when using an absolute encoder.

Type	Signal Name	Connector Pin Number	Name
Input	SEN	CN1-5	SEN Signal Input
	SG	CN1-6	Signal Ground
	BAT (+)	CN1-28	Battery (+)
	BAT (-)	CN1-29	Battery (-)
Output	SG*	CN1-10	Signal Ground

* SG (CN1-1, 2): Connect to 0 V on the host controller.

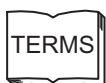

Dividing

The dividing means that the divider converts data into the pulse density based on the pulse data of the encoder installed on the servomotor, and outputs it. The setting unit is the number of pulses/revolution.

IMPORTANT

If using the SERVOPACK's phase-C pulse output for a zero point return, rotate the servomotor twice or more before starting a zero point return. If the configuration prevents the servomotor from rotating the servomotor or more, perform a zero point return at a motor speed of 600 min^{-1} or below. If the motor speed is faster than 600 min^{-1} , the phase-C pulse output may not be output correctly.

- Pulse Dividing Ratio Setting

Pn201	PG Divider			<input type="checkbox"/> Speed <input type="checkbox"/> Position <input type="checkbox"/> Torque
	Setting Range	Setting Unit	Factory Setting	Setting Validation
	16 to 16384	P/Rev	16384	After restart

Set the number of pulses for PG output signals (PAO, /PAO, PBO, /PBO) externally from the SERVOPACK. Feedback pulses from the encoder per revolution are divided inside the SERVOPACK by the number set in Pn201 before being output. (Set according to the system specifications of the machine or host controller.)

The setting range varies with the number of encoder pulses for the servomotor used.

Motor Model Encoder Specifications	Resolution (Bit)	No. of Pulses (P/R)	Setting Range
A	13	2048	16 to 2048
1	16	16384	16 to 16384

■ Output Example
Pn201=16 (when 16 pulses are output per revolution)

8.5.8 Speed Coincidence Output

The speed coincidence (/V-CMP) output signal is output when the actual motor speed during speed control is the same as the speed reference input. The host controller uses the signal as an interlock.

Type	Signal Name	Connector Pin Number	Setting	Meaning
Output	/V-CMP	CN1-8, 10 (Factory setting)	ON (low level)	Speed coincides.
			OFF (high level)	Speed does not coincide.
This output signal can be allocated to another output terminal with parameter Pn50E. Refer to 7.3.3 <i>Output Circuit Signal Allocation</i> for details.				

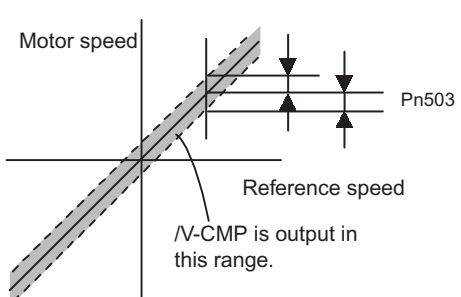
Pn503	Speed Coincidence Signal Output Width Speed			
	Setting Range	Setting Unit	Factory Setting	Setting Validation
	0 to 100	min ⁻¹	10	Immediately
<p>The /V-CMP signal is output when the difference between the speed reference and actual motor speed is the same as the pn503 setting or less.</p> <p>■ EXAMPLE</p> <p>The /V-CMP signal turns ON at 1900 to 2100 min⁻¹ if the Pn503 parameter is set to 100 and the reference speed is 2000 min⁻¹.</p> <div style="display: flex; align-items: center;">  <div style="margin-left: 20px;"> <p>Pn503</p> <p>Reference speed</p> <p>/V-CMP is output in this range.</p> </div> </div> <p>/V-CMP is a speed control output signal. When the factory setting is used and the output terminal allocation is not performed with the Pn50E, this signal is automatically used as the positioning completed signal /COIN for position control, and it is always OFF (high level) for torque control.</p>				

8.6 Operating Using Position Control



8.6.1 Setting Parameters

(1) Control Mode Selection

Parameter	Meaning
Pn000 n.□□1□	Control mode selection: Position control (pulse train reference) (factory setting)

(2) Setting a Reference Pulse Form

Type	Signal Name	Connector Pin Number	Name
Input	PULS	CN1-1	Reference Pulse Input
	/PULS	CN1-2	Reference Pulse Input
	SIGN	CN1-3	Reference Code Input
	/SIGN	CN1-4	Reference Code Input

Set the input form for the SERVOPACK using parameter Pn200.0 according to the host controller specifications.

Parameter	Reference Pulse Form	Input Pulse Multiplier	Forward Rotation Reference	Reverse Rotation Reference	
Pn200	n.□□□0	Sign + pulse train (Positive logic) (Factory setting)	—		
	n.□□□1	CW pulse + CCW pulse (Positive logic)	—		
	n.□□□2	Two-phase pulse train with 90° phase differential (Positive logic)	×1		
	n.□□□3		×2		
	n.□□□4		×4		
	n.□□□5	Sign + pulse train (Negative logic)	—		
	n.□□□6	CW pulse + CCW pulse (Negative logic)	—		
	n.□□□7	Two-phase pulse train with 90° phase differential (Negative logic)	×1		
	n.□□□8		×2		
n.□□□9	×4				

The input pulse multiplier can be set for the 2-phase pulse train with 90° phase differential reference pulse form.

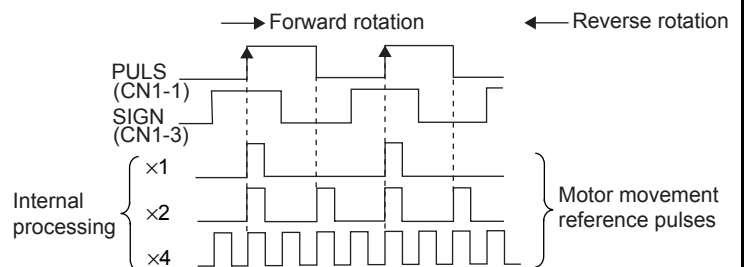

(3) Clear Signal Form Selection

Type	Signal Name	Connector Pin Number	Name
Input	CLR	CN1-5	Clear Input
	/CLR	CN1-6	Clear Input

The internal processing of the SERVOPACK for the clear signal can be set to either of four types by parameter Pn200.1. Select according to the specifications of the machine or host controller.

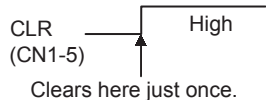
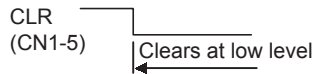
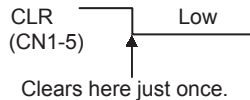
Parameter	Description	Timing	
Pn200	n.□□0□	Clears at high level. Position error pulses do not accumulate while the signal is at high level. (Factory setting)	
	n.□□1□	Clears at the rising edge.	
	n.□□2□	Clears at low level. Position error pulses do not accumulate while the signal is at low level.	
	n.□□3□	Clears at the falling edge.	

The following are executed when the clear operation is enabled.

- The SERVOPACK error counter is set to 0.
- Position loop operation is disabled.
→ Holding the clear status may cause the servo clamp to stop functioning and the servomotor to rotate slowly due to drift in the speed loop.

When the clear signal (CLR) is not wired, the signal is always at low level (does not clear).

When the clear signal (CLR) is not used and CN1-5, 6 are not wired, the CLR input terminals (CN1-5, 6) are always at high level. The SERVOPACK is Pn200.1 factory set to clear position error pulse at high level. Even if a pulse train reference is input with the setting in this state, the pulses will be constantly cleared and the motor will not operate. Set the parameter to a value other than Pn200 = n.□□0□, or short-circuit CN1-5, 6.

(4) Clear Operation Selection

This parameter determines when the error pulse should be cleared according to the condition of the SERVOPACK, in addition to the clearing operation of the clear signal (/CLR). Either of three clearing modes can be selected with Pn200.2

Parameter	Description	
Pn200	n.□0□□ (Factory setting)	Clear the error pulse at the /CLR signal input during the baseblock. “During the baseblock” means when the SVON signal or the main circuit power supply is OFF, or an alarm occurs.
	n.□1□□	Do not clear the error pulse. Clear only with the /CLR signal.
	n.□2□□	Clear the error pulse when an alarm occurs or the /CLR signal is input.

8.6.2 Setting the Electronic Gear

(1) Number of Encoder Pulses

SGMAJ-□□□□□□□□ (Servomotor serial number)

Motor Model Encoder Specifications	Encoder Type	No. of Encoder Pulses	
A	Incremental encoder	13 bits	2048
1	Absolute encoder	16 bits	16384

Note: For details on reading servomotor model numbers, refer to 2.1 *Servomotor Model Designations*.



The number of bits representing the resolution of the applicable encoder is not the same as the number of encoder signal pulses (phases A and B). The number of bits representing the resolution is equal to the number of encoder pulses \times 4 (multiplier).

(2) Electronic Gear

The electronic gear enables the workpiece travel distance per input reference pulse from the host controller to be set to any value. One reference pulse from the host controller, i.e., the minimum position data unit, is called a reference unit.

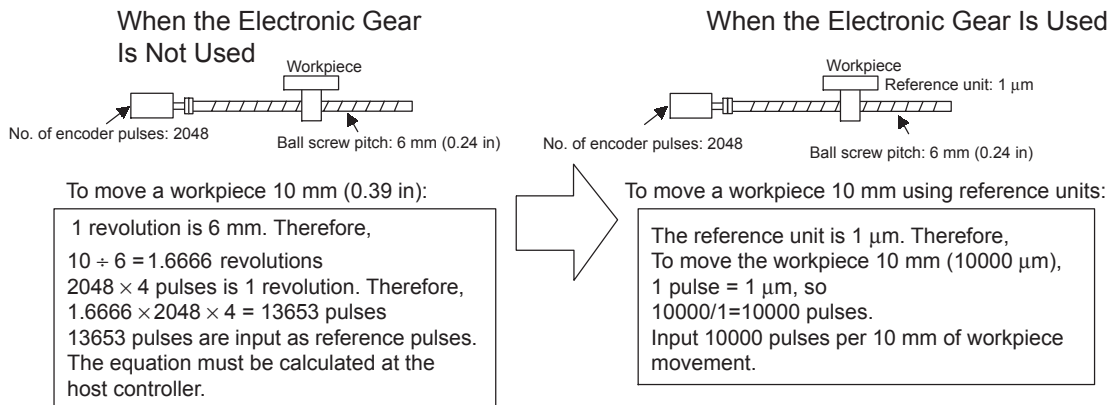

(3) Related Parameters

Pn202	Electronic Gear Ratio (Numerator) Position			
	Setting Range	Setting Unit	Factory Setting	Setting Validation
	1 to 65535	–	4	After restart
Pn203	Electronic Gear Ratio (Denominator) Position			
	Setting Range	Setting Unit	Factory Setting	Setting Validation
	1 to 65535	–	1	After restart
<p>If the deceleration ratio of the servomotor and the load shaft is given as n/m where m is the rotation of the servomotor and n is the rotation of the load shaft,</p> $\text{Electronic gear ratio: } \frac{B}{A} = \frac{\text{Pn202}}{\text{Pn203}} = \frac{\text{No. of encoder pulses} \times 4}{\text{Travel distance per load shaft revolution (reference units)}} \times \frac{m}{n}$ <p>* If the ratio is outside the setting range, reduce the fraction (both numerator and denominator) until you obtain integers within the range. Be careful not to change the electronic gear ratio (B/A).</p> <p>■ IMPORTANT Electronic gear ratio setting range: $0.01 \leq \text{Electronic gear ratio (B/A)} \leq 100$ If the electronic gear ratio is outside this range, the SERVOPACK will not operate properly. In this case, modify the load configuration or reference unit.</p>				

(4) Procedure for Setting the Electronic Gear Ratio

Use the following procedure to set the electronic gear ratio.

Step	Operation	Description
1	Check machine specifications.	Check the deceleration ratio, ball screw pitch, and pulley diameter.
2	Check the number of encoder pulses.	Check the number of encoder pulses for the servomotor used.
3	Determine the reference unit used.	Determine the reference unit from the host controller, considering the machine specifications and positioning accuracy.
4	Calculate the travel distance per load shaft revolution.	Calculate the number of reference units necessary to turn the load shaft one revolution based on the previously determined reference units.
5	Calculate the electronic gear ratio.	Use the electronic gear ratio equation to calculate the ratio (B/A).
6	Set parameters.	Set parameters using the calculated values.

(5) Electronic Gear Ratio Setting Examples

The following examples show electronic gear ratio settings for different load configurations.

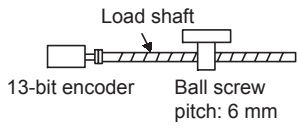
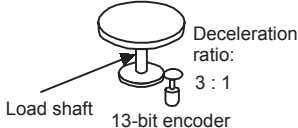
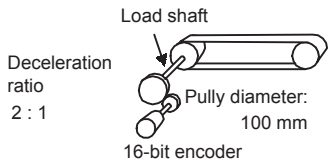
Step	Operation	Load Configuration					
		Ball Screw		Disc Table		Belt and Pulley	
		Reference unit: 0.001 mm 		Reference unit: 0.1° 		Reference Unit: 0.02 mm 	
1	Check machine specifications.	• Ball screw pitch: 6 mm • Deceleration ratio: 1/1		Rotation angle per revolution: 360° Deceleration ratio: 3/1		Pulley diameter: 100 mm (pulley circumference: 314 mm) • Deceleration ratio: 2/1	
2	Check the number of encoder pulses.	13-bit: 2048 P/R		13-bit: 2048 P/R		16-bit: 16384 P/R	
3	Determine the reference unit used.	1 Reference unit: 0.001 mm (1 μm)		1 Reference unit: 0.01°		1 Reference unit: 0.02 mm (20 μm)	
4	Calculate the travel distance per load shaft revolution.	6 mm/0.001 mm=6000		360°/0.1°=3600		314 mm/0.02 mm=15700	
5	Calculate the electronic gear ratio.	$\frac{B}{A} = \frac{2048 \times 4}{6000} \times \frac{1}{1}$		$\frac{B}{A} = \frac{2048 \times 4}{3600} \times \frac{3}{1}$		$\frac{B}{A} = \frac{16384 \times 4}{15700} \times \frac{2}{1}$	
6	Set parameters.	Pn202	8192	Pn202	24576	Pn202	131072*
		Pn203	6000	Pn203	3600	Pn203	15700

Reduce the fraction (both numerator and denominator) since the calculated result will not be within the setting range. For example, reduce the numerator and denominator by four to obtain Pn202=32768, Pn203=3925 and complete the settings.

(6) Electronic Gear Ratio Equation

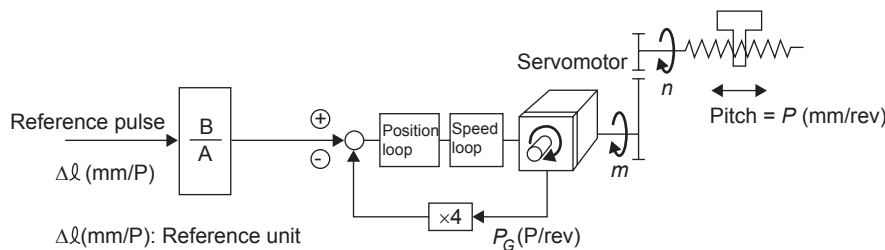

- Δl(mm/P): Reference unit
- P_G(P/R): Encoder pulses
- P (mm/rev): Ball screw pitch
- $\frac{m}{n}$: Deceleration ratio

$$\frac{n \times P}{\Delta l} \times \left(\frac{B}{A} \right) = 4 \times P_G \times m$$

$$\left(\frac{B}{A} \right) = \frac{4 \times P_G \times m \times \Delta l}{n \times P} = \frac{4 \times P_G}{P} \times \frac{m}{n}$$

Set A and B with the following parameters.

A: Pn203 **B**: Pn202

8.6.3 Position Reference

The servomotor positioning is controlled by inputting a pulse train reference.

The pulse train output form from the host controller corresponds to the following:

- Line-driver Output
- +24V Open-collector output
- +12V Open-collector output
- +5V Open-collector output

IMPORTANT

■Precautions for Open-collector Output

When the open-collector output is used, input signal noise margin lowers. Change the parameter as follows:

Parameter	Description
Pn200	n.1□□□ Reference input filter for open-collector signal

(1) Input/Output Signal Timing Example

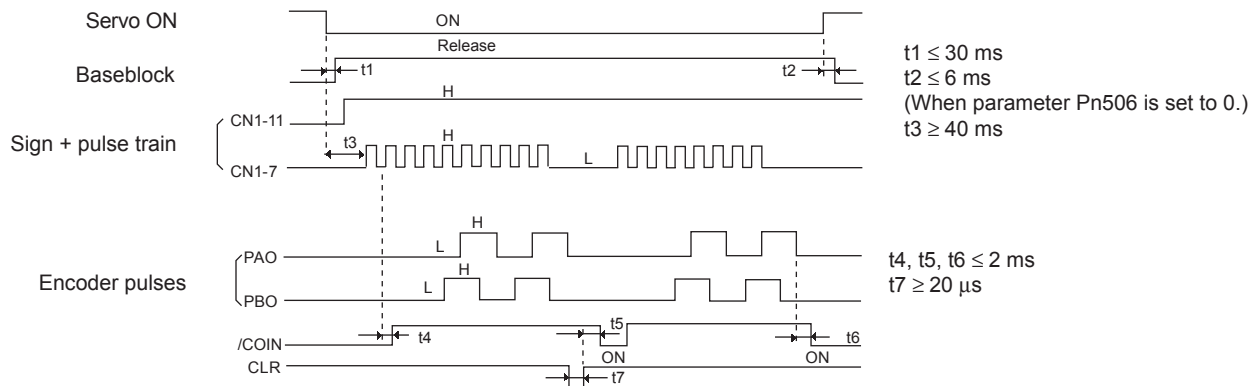

Note: 1. The interval from the time the servo ON signal is turned ON until a reference pulse is input must be at least 40 ms, otherwise the reference pulse may not be received by the SERVOPACK.

2. The error counter clear signal must be ON for at least 20 μ s.

Table 8.1 Reference Pulse Input Signal Timing

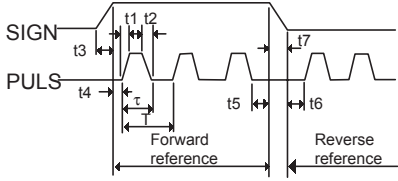
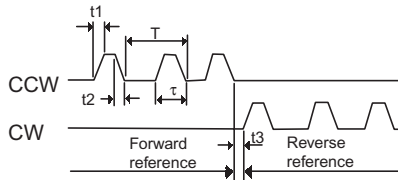
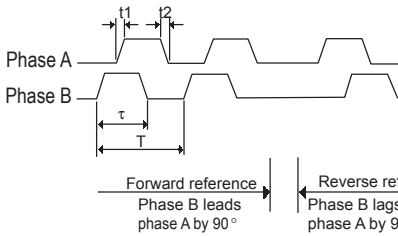
Reference Pulse Signal Form	Electrical Specifications	Remarks
<p>Sign and pulse train input (SIGN and PULS signal) Maximum reference frequency: 500 kpps (For open-collector output: 200 kpps)</p>	 <p>$t_1, t_2 \leq 0.1 \text{ ms}$ $t_3, t_7 \leq 0.1 \text{ ms}$ $t_4, t_5, t_6 > 3 \mu\text{s}$ $\tau \geq 1.0 \mu\text{s}$ $(\tau/T) \times 100 \leq 50\%$</p>	<p>Sign (SIGN) H = Forward reference L = Reverse reference</p>
<p>CW pulse and CCW pulse Maximum reference frequency: 500 kpps (For open-collector output: 200 kpps)</p>	 <p>$t_1, t_2 \leq 0.1 \text{ ms}$ $t_3 > 3 \mu\text{s}$ $\tau \geq 1.0 \mu\text{s}$ $(\tau/T) \times 100 \leq 50\%$</p>	<p>—</p>
<p>Two-phase pulse train with 90° phase differential (phase A and phase B) Maximum reference frequency ×1 input pulse multiplier: 500 kpps ×2 input pulse multiplier: 400 kpps ×4 input pulse multiplier: 200 kpps</p>	 <p>$t_1, t_2 \leq 0.1 \text{ ms}$ $\tau \geq 1.0 \mu\text{s}$ $(\tau/T) \times 100 = 50\%$</p> <p>Forward reference: Phase B leads phase A by 90° Reverse reference: Phase B lags phase A by 90°</p>	<p>Switching of the input pulse multiplier mode is done with parameter Pn200.0 setting.</p>

(2) Connection Example

(a) Connection Example for Line-driver Output

Applicable line driver: SN75174 manufactured by Texas Instruments Inc., or MC3487 or equivalent

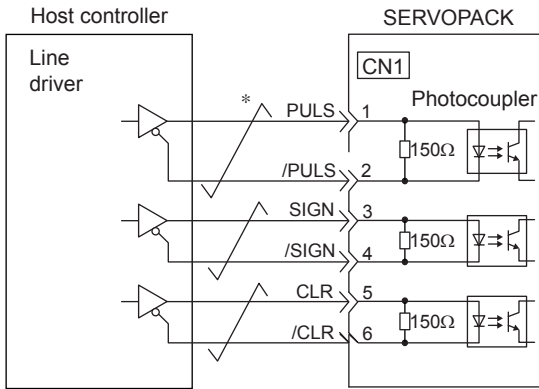

* : Represents twisted-pair wires.

(b) Connection Example for Open-collector Output

Select the limit resistance R1 value so that the input current i will be within 7 to 15 mA.

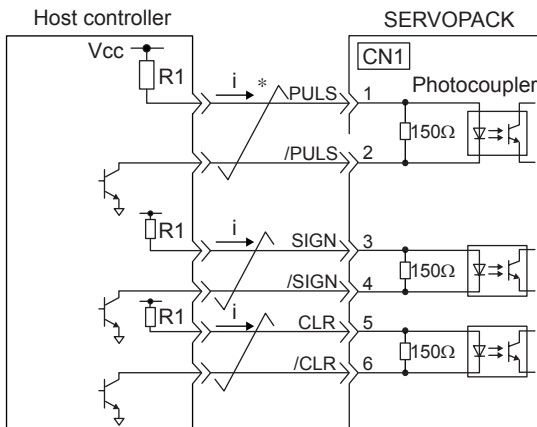

* : Represents twisted-pair wires.

Example

- When V_{cc} is +24V: $R1=2.2\text{ k}\Omega$
- When V_{cc} is +12V: $R1=1\text{ k}\Omega$
- When V_{cc} is +5V: $R1=180\ \Omega$

Note: When the open-collector output is used, the signal logic is as follows:

When Tr1 is ON	High level input or equivalent
When Tr1 is OFF	Low level input or equivalent

IMPORTANT

When the open-collector output is used, input signal noise margin lowers. Set the parameter Pn200.3 to 1.

(3) Position Control Block Diagram

A block diagram for position control is shown below.

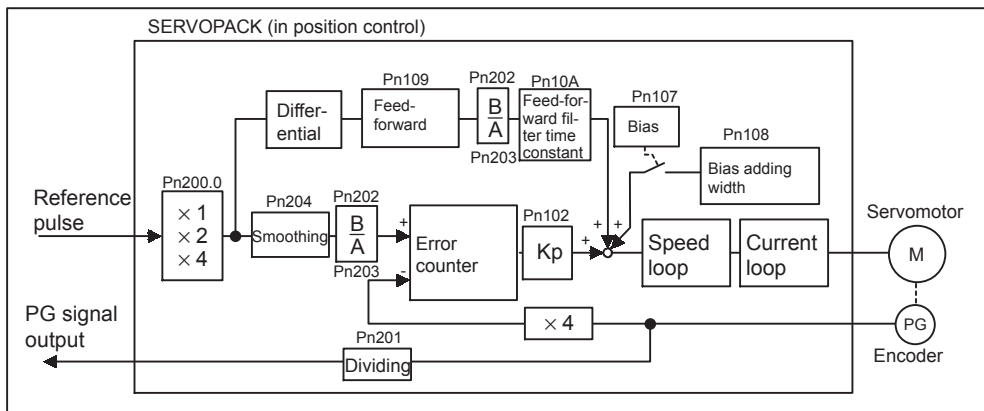

8.6.4 Smoothing

A filter can be applied in the SERVOPACK to a constant-frequency reference pulse.

(1) Selecting a Position Reference Filter

Parameter	Description
Pn207 n.□□□0	Acceleration/deceleration filter
n.□□□1	Average movement filter

* After resetting the parameter, turn OFF the power once and turn it ON again.

(2) Filter-related Parameters

Pn204	Position Reference Acceleration/Deceleration Time Constant			Position
	Setting Range	Setting Unit	Factory Setting	Setting Validation
	0 to 6400 (0 to 64.00 ms)	0.01 ms	0 (0.00 ms)	Immediately
Pn208	Average Movement Time of Position Reference			Position
	Setting Range	Setting Unit	Factory Setting	Setting Validation
	0 to 6400	0.01 ms	0	Immediately

■ IMPORTANT

When the position reference acceleration/deceleration time constant (Pn204) is changed, a value with no reference pulse input and a position error of 0 will be enabled. To ensure that the setting value is correctly reflected, stop the reference pulse from the host controller and input the clear signal (/CLR), or turn the servo OFF to clear the error.

This function provides smooth motor operating in the following cases. The function does not affect the travel distance (i.e., the number of pulses).

- When the host controller that outputs a reference cannot perform acceleration/deceleration processing.
- When the reference pulse frequency is too low.
- When the reference electronic gear ratio is too high (i.e., 10× or more).

The difference between the position reference acceleration/deceleration time constant (Pn204) and the position reference movement averaging time (Pn208) is shown below.

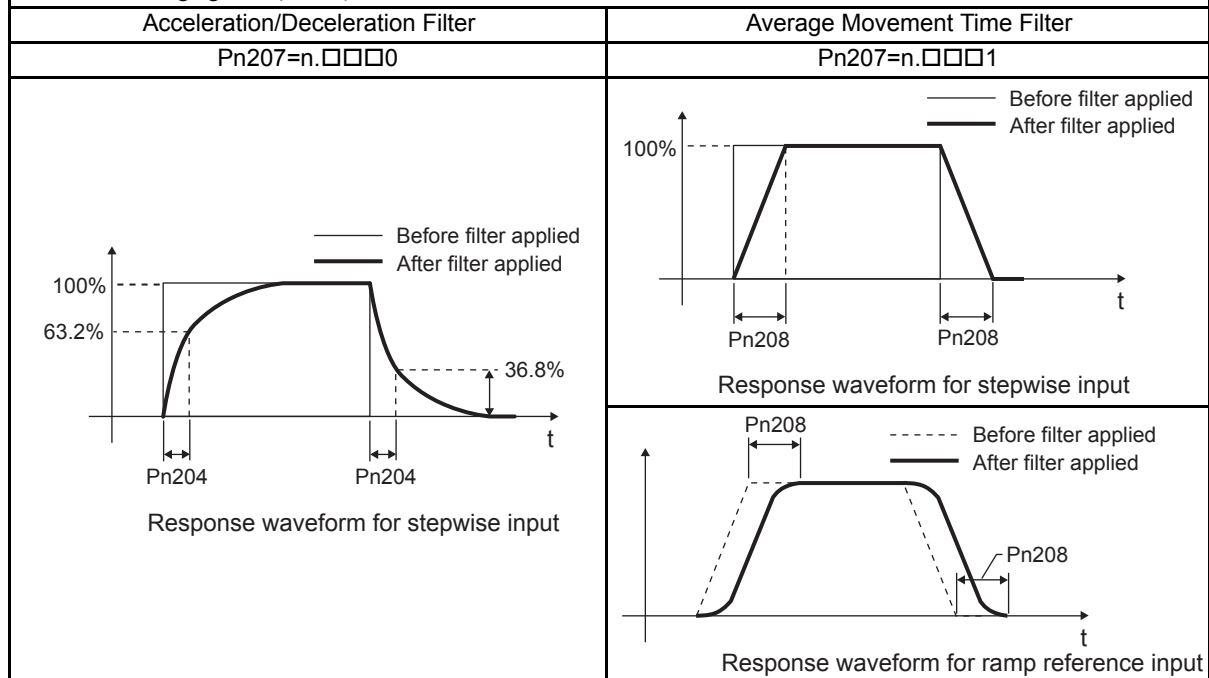

8.6.5 Positioning Completed Output Signal

This signal indicates that servomotor movement has been completed during position control. Use the signal as an interlock to confirm at the host controller that positioning has been completed.

Type	Signal Name	Connector Pin Number	Setting	Meaning
Output	/COIN	CN1-8, 10 (Factory setting)	ON (low level)	Positioning has been completed.
			OFF (high level)	Positioning is not completed.

This output signal can be allocated to an output terminal with parameter Pn50E. Refer to 7.3.3 *Output Circuit Signal Allocation* for details. The factory setting is allocated to CN1-8, 10.

Pn500	Positioning Completed Width Position			
	Setting Range	Setting Unit	Factory Setting	Setting Validation
	0 to 250	Reference units	7	Immediately

The positioning completed (/COIN) signal is output when the difference (position error pulse) between the number of reference pulses output by the host controller and the travel distance of the servomotor is less than the value set in this parameter.

Set the number of error pulses in reference units (the number of input pulses defined using the electronic gear.)

Too large a value at this parameter may output only a small error during low-speed operation that will cause the /COIN signal to be output continuously.

If a servo gain is set that keeps the position error small even when the positioning completed width is large, use Pn207 = n.1□□□ to enable correct output timing for the COIN signal.

The positioning completed width setting has no effect on final positioning accuracy.

8.6.6 Positioning Near Signal

This signal indicates that the positioning of the servomotor is near to completion, and is generally used in combination with the positioning completed (/COIN) output signal.

The host controller receives the positioning near signal prior to confirming the positioning-completed signal, and performs the following operating sequence after positioning has been completed to shorten the time required for operation.

Type	Signal Name	Connector Pin Number	Setting	Meaning
Output	/NEAR	Must be allocated	ON (low level)	The servomotor has reached a point near to positioning completed.
			OFF (high level)	The servomotor has not reached a point near to positioning completed.
The output terminal must be allocated with parameter Pn510 in order to use positioning near signal. Refer to 7.3.3 <i>Output Circuit Signal Allocation</i> for details.				

Pn504	NEAR Signal Width Position			
	Setting Range	Setting Unit	Factory Setting	Setting Validation
	1 to 250	Reference units	7	Immediately
<p>The positioning near (/NEAR) signal is output when the difference (error) between the number of reference pulses output by the host controller and the travel distance of the servomotor is less than the value set in Pn504.</p> <p>Set the number of error pulses in reference units (the number of input pulses defined using the electronic gear.)</p> <p>Normally, the setting should be larger than that for the positioning completed width (Pn500).</p>				
<p>The diagram illustrates the relationship between speed, error, and output signals. The top graph shows Speed vs. Position, with a dashed line for Reference and a solid line for Motor speed. The middle graph shows Error pulse vs. Position, with a pulse between Pn504 and Pn500. The bottom graph shows the /NEAR and /COIN signals, where /NEAR is high during the error pulse and /COIN is high after the error pulse ends.</p>				

8.6.7 Reference Pulse Inhibit Function (INHIBIT)

(1) Description

This function inhibits the SERVOPACK from counting input pulses during position control. The servomotor remains locked (clamped) while pulse are inhibited.

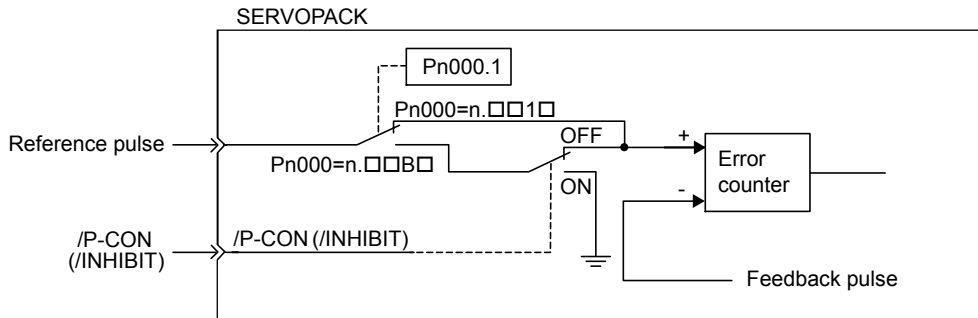

(2) Setting Parameters

Parameter	Meaning
Pn000 n.□□B□	Control mode selection: Position control (pulse train reference) ↔ Inhibit
<ul style="list-style-type: none"> Inhibit (INHIBIT) switching condition · /P-CON (/INHIBIT) signal ON (low level) 	<p>Input reference pulses are not counted during this period.</p>

(3) Setting Input Signals

Type	Signal Name	Connector Pin Number	Setting	Meaning
Input	/P-CON	CN1-15 (Factory setting)	ON (low level)	Turns the INHIBIT function ON. (Inhibits the SERVOPACK from counting reference pulses.)
			OFF (high level)	Turns the INHIBIT function OFF. (Counts reference pulses.)
(Input)	(/INHIBIT)	Must be allocated CN1-□□	ON (low level)	Turns the INHIBIT function ON. (Inhibits the SERVOPACK from counting reference pulses.)
			OFF (high level)	Turns the INHIBIT function OFF. (Counts reference pulses.)

These input signals enable the inhibit function.

Either the /P-CON or the /INHIBIT signal can be used to switch the inhibit signal. The input signal must be allocated in order to use the /INHIBIT signal. Refer to 7.3.2 *Input Circuit Signal Allocation*.

8.7 Operating Using Torque Control

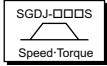

8.7.1 Setting Parameters

The following parameters must be set for torque control operation with analog voltage reference.

Parameter	Meaning
Pn000	n.□□2□ Control mode selection: Torque control (analog voltage reference)

Pn400	Torque Reference Input Gain			
	Setting Range	Setting Unit	Factory Setting	Setting Validation
	10 to 100 (1.0 to 10.0 V/rated torque)	0.1V/rated torque	30 (3.0 V/rated torque)	Immediately

This sets the analog voltage level for the torque reference (T-REF) that is necessary to operate the servomotor at the rated torque.

■ EXAMPLE

Pn400 = 30: The servomotor operates at the rated torque with 3-V input (factory setting).

Pn400 = 1000: The servomotor operates at the rated torque with 10-V input.

Pn400 = 200: The servomotor operates at the rated torque with 2-V input.

8.7.2 Torque Reference Input

By applying a torque reference determined by the analog voltage reference to the SERVOPACK, the servomotor torque can be controlled in proportion with the input voltage.

Type	Signal Name	Connector Pin Number	Name
Input	T-REF	CN1-1	Torque Reference Input
	SG	CN1-2	Signal Ground for Torque Reference Input

Used during torque control (analog voltage reference). (Pn000.1 = 2, 6, 9)
 The torque reference gain is set in Pn400. For setting details, refer to 8.7.1 Setting Parameters.

■ Input Specifications

- Input range: ± 1 to ± 10 VDC/rated torque
- Max. allowable input voltage: ± 12 VDC
- Factory setting

Pn400 = 30: Rated torque at 3 V
 +3-V input: Rated torque in forward direction
 +9-V input: 300% rated torque in forward direction
 -0.3-V input: 10% rated torque in reverse direction

The voltage input range can be changed with parameter Pn400.

■ Input Circuit Example

Use twisted-pair wires as a countermeasure against noise.
 Variable resistor example: Model 25HP-10B manufactured by Sakae Tsushin Kogyo Co., Ltd.



■ Checking the Internal Torque Reference

1. Checking the internal torque reference with the panel operator:
Use the Monitor Mode (Un-002). Refer to *7.4 Operation in Monitor Mode (Un□□□□)*.
2. Checking the internal torque reference with an analog monitor:
The internal torque reference can also be checked with an analog monitor. Refer to *9.5 Analog Monitor*.

8.7.3 Adjusting the Reference Offset

(1) Automatic Adjustment of the Torque Reference Offset

When using torque control, the servomotor may rotate slowly even when 0 V is specified as the analog reference voltage. This occurs when the host controller or external circuit has a slight offset (measured in mV) in the reference voltage. In this case, the reference offset can be adjusted automatically and manually using the digital operator.

The automatic adjustment of analog (speed, torque) reference offset (Fn009) automatically measures the offset and adjusts the reference voltage.

The SERVOPACK performs the following automatic adjustment when the host controller or external circuit has an offset in the reference voltage.

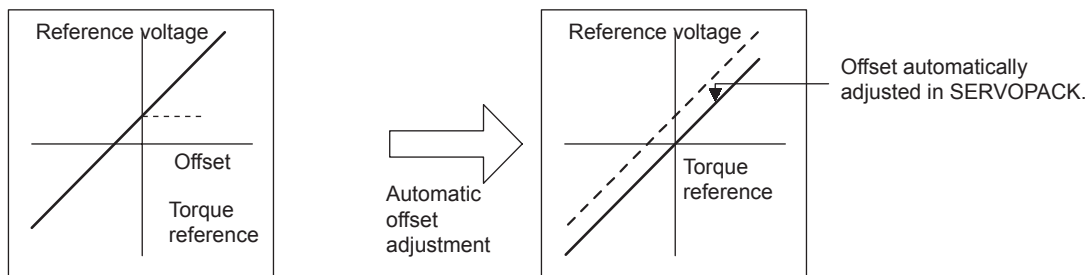

After completion of the automatic adjustment, the amount of offset is stored in the SERVOPACK. The amount of offset can be checked in the manual adjustment of torque reference offset (Fn00B).

The automatic adjustment of analog reference offset (Fn009) cannot be used when a position loop has been formed with the host controller and the error pulse is changed to zero at the servomotor stop due to servolock. Use the torque reference offset manual adjustment (Fn00B).

IMPORTANT

The analog reference offset must be automatically adjusted with the servo OFF.

Use the following procedure for automatic adjustment of the torque reference offset.

Step	Display after Operation	Key	Description
1			Turn OFF the SERVOPACK, and input the 0-V reference voltage from the host controller or external circuit.
2		 (DSPL/SET Key)	Press the DSPL/SET Key to select the utility function mode.
3			Press the LEFT/RIGHT or UP/DOWN Key, or UP or DOWN Key to select parameter Fn009. *The digit that can be set will blink.
4		 (DATA/ENTER Key)	Press the DATA/ENTER Key. "rEF_o" will be displayed.
5		 (DSPL/SET Key)	Press the DSPL/SET Key. The reference offset will be automatically adjusted. When completed, "donE" will blink for about one second.
6		About one second later	After "donE" is displayed, "rEF_o" will be displayed again.
7		 (DATA/ENTER Key)	Press the DATA/ENTER Key to return to the Fn009 display of the utility function mode.

(2) Manual Adjustment of the Torque Reference Offset

Manual adjustment of the torque reference offset (Fn00B) is used in the following cases.

- If a position loop is formed with the host controller and the error is zeroed when servolock is stopped.
- To deliberately set the offset to some value.
- Use this mode to check the offset data that was set in the automatic adjustment mode of the torque reference offset.

This mode operates in the same way as the automatic adjustment mode (Fn009), except that the amount of offset is directly input during the adjustment.

The offset adjustment range and setting units are as follows:

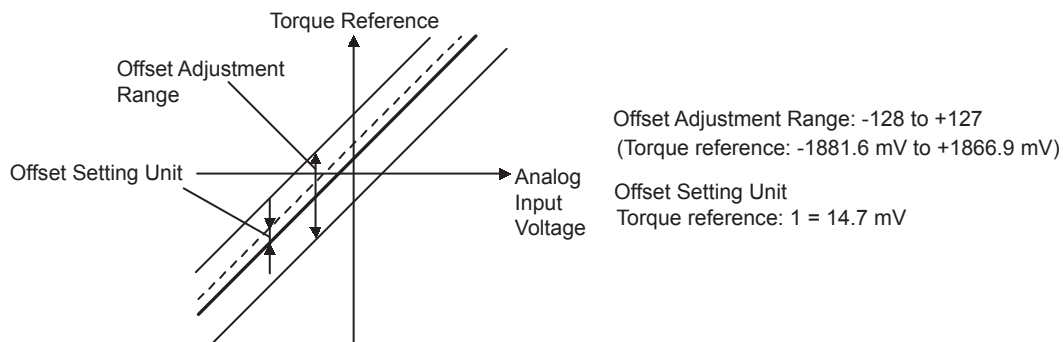

Use the following procedure to manually adjust the torque reference offset.

Step	Display after Operation	Key	Description
1		 (DSPL/SET Key)	Press the DSPL/SET Key to select the utility function mode.
2			Press the LEFT/RIGHT or UP/DOWN Key or UP or DOWN Key to select parameter Fn00B. *The digit that can be set will blink.
3		 (DATA/ENTER Key)	Press the DATA/ENTER Key. The display will be as shown at the left. The manual adjustment mode for the torque reference offset will be entered.
4		Servo ON	Turn ON the servo ON (/S-ON) signal. The display will be as shown at the left.
5			Press the LEFT or RIGHT Key to display the torque reference offset amount.
6			Press the UP or DOWN Key to adjust the amount of offset.
7			Press the LEFT or RIGHT Key to return to the display shown on the left.
8		 (DATA/ENTER Key)	Press the DATA/ENTER Key to return to the Fn00B display of the utility function mode.

8.7.4 Limiting Servomotor Speed during Torque Control

During torque control, the servomotor is controlled to output the specified torque, which means that the servomotor speed is not controlled. Accordingly, when an excessive reference torque is set for the mechanical load torque, it will prevail over the mechanical load torque and the servomotor speed will greatly increase.

This function serves to limit the servomotor speed during torque control to protect the machine.

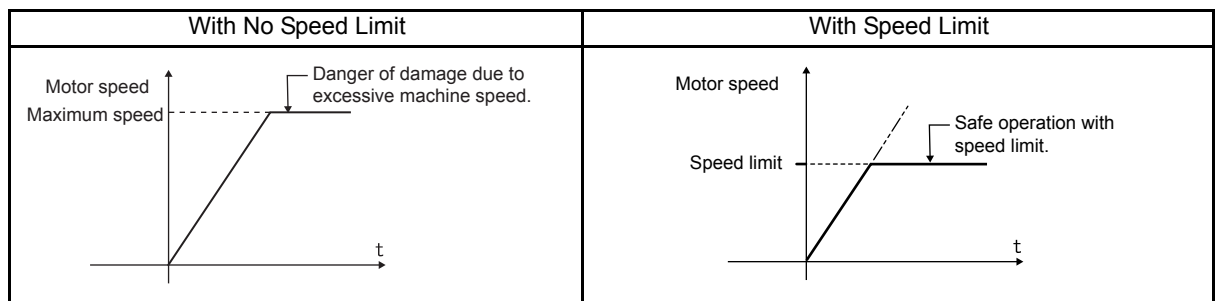

(1) Speed Limit Mode Selection (Torque Limit Option)

Parameter	Description
Pn002 n.□□0□	Uses the value set in Pn407 as the speed limit (internal speed limit function).
n.□□1□	Uses V-REF (CN1-3, 4) as an external speed limit input. Applies a speed limit using the input voltage of V-REF and the setting in Pn300 (external speed limit function).

(2) Internal Speed Limit Function

Pn407	Speed Limit During Torque Control Torque			
	Setting Range	Setting Unit	Factory Setting	Setting Validation
	0 to 10000	min ⁻¹	10000	Immediately

Sets the servomotor speed limit value during torque control.
The setting in this parameter is enabled when Pn002 = n.□□0□.
The servomotor's maximum speed will be used when the setting in this parameter exceeds the maximum speed of the servomotor used.

(3) External Speed Limit Function

Type	Signal Name	Connector Pin Number	Name
Input	V-REF	CN1-3	External Speed Limit Input
	SG	CN1-4	Signal Ground

Inputs an analog voltage reference as the servomotor speed limit value during torque control.
The smaller value is enabled, the speed limit input from V-REF or the Pn407 (Speed Limit during Torque Control) when Pn002 = n.□□1□.
The setting in Pn300 determines the voltage level to be input as the limit value. Polarity has no effect.

Pn300	Speed Reference Input Gain Speed Position Torque			
	Setting Range	Setting Unit	Factory Setting	Setting Validation
	150 to 3000 (1.50 to 30.0 V/rated speed)	0.01 V/rated speed	600 (6.00 V/rated speed)	Immediately

Sets the voltage level for the speed that is to be externally limited during torque control.
With Pn300 = 600 (factory setting) and 6 V input from V-REF (CN1-3, 4), the actual motor speed is limited to the rated speed of the servomotor used.



■ The Principle of Speed Limiting

When the speed is outside of the allowable range, a torque that is proportional to the difference between the actual speed and the speed limit is used as negative feedback to bring the speed back within the speed limit range. Accordingly, there is a margin generated by the load conditions in the actual motor speed limit value.

(4) Signals Output during Servomotor Speed Limit

Type	Signal Name	Connector Pin Number	Setting	Meaning
Output	/VLT	Must be allocated CN1-□□	ON (low level)	Servomotor speed limit being applied.
			OFF (high level)	Servomotor speed limit not being applied.

This signal is output when the servomotor speed reaches the speed limit value set in Pn407 or set by the analog voltage reference.
For use, this output signal must be allocated with parameter Pn50F. For details, refer to 7.3.3 *Output Circuit Signal Allocation*.

8.8 Operating Using Speed Control with an Internally Set Speed



• Internally Set Speed Selection

This function allows speed control operation by externally selecting an input signal from among three servomotor speed settings made in advance with parameters in the SERVOPACK. The speed control operations within the three settings are valid. There is no need for an external speed or pulse generator.

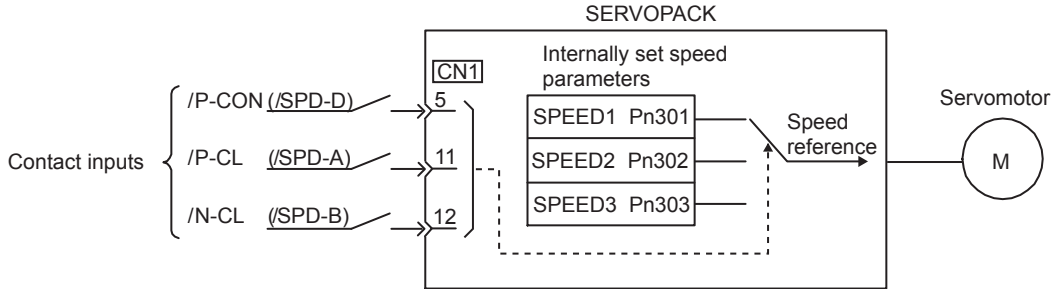

8.8.1 Setting Parameters

Parameter	Meaning
Pn000 n.□□3□	Control mode selection: Internally set speed control (contact reference)

Note: If only Pn000.1 = 5 (Internally set speed control ↔ Position control), any operation which uses the internally set speed selection will be valid when using the SGDJ-□□□P SERVOPACK.

Pn301	Internally set speed 1 (SPEED1)	Speed		
	Setting Range	Setting Unit	Factory Setting	Setting Validation
	0 to 10000	min ⁻¹	100	Immediately
Pn302	Internally set speed 2 (SPEED2)	Speed		
	Setting Range	Setting Unit	Factory Setting	Setting Validation
	0 to 10000	min ⁻¹	200	Immediately
Pn303	Internally set speed 3 (SPEED3)	Speed		
	Setting Range	Setting Unit	Factory Setting	Setting Validation
	0 to 10000	min ⁻¹	300	Immediately

Note: The maximum speed of servomotor is used whenever a speed settings for the Pn301 to Pn303 exceed the maximum speed.

8.8.2 Input Signal Settings

The following input signals are used to switch the operating speed.

Type	Signal Name	Connector Pin Number	Meaning
Input	/P-CON	CN1-15	Switches the servomotor rotation direction.
	(/SPD-D)	Must be allocated	
Input	/P-CL	CN1-11	Selects the internally set speed.
	(/SPD-A)	Must be allocated	
Input	/N-CL	CN1-12	Selects the internally set speed.
	(/SPD-B)	Must be allocated	

■ Input Signal Selection

The following two types of operation can be performed using the internally set speeds:

- Operation with the /P-CON, /P-CL, and /N-CL input signals (pins allocated in factory setting)
- Operation with the /SPD-D, /SPD-A, and /SPD-B input signals

/SPD-D, /SPD-A, and /SPD-B input signals must be allocated with parameter Pn50C. Refer to 7.3.2 *Input Circuit Signal Allocation*.

8.8.3 Operating Using an Internally Set Speed

Use ON/OFF combinations of the following input signals to operate with the internally set speeds.

Input Signal			Motor Rotation Direction	Speed
/P-CON (/SPD-D)	/P-CL (/SPD-A)	/N-CL (/SPD-B)		
OFF (high)	OFF (high)	OFF (high)	Forward	Stop at 0 of the internally set speed
	OFF (high)	ON (low)		Pn301: Internally Set Speed 1 (SPEED1)
	ON (low)	ON (low)		Pn302: Internally Set Speed 2 (SPEED2)
	ON (low)	OFF (high)		Pn303: Internally Set Speed 3 (SPEED3)
ON (low)	OFF (high)	OFF (high)	Reverse	Stop at 0 of the internally set speed
	OFF (high)	ON (low)		Pn301: Internally Set Speed 1 (SPEED1)
	ON (low)	ON (low)		Pn302: Internally Set Speed 2 (SPEED2)
	ON (low)	OFF (high)		Pn303: Internally Set Speed 3 (SPEED3)

Note: Signal OFF = High level; Signal ON = Low level

IMPORTANT

■ Control Mode Switching

When Pn000.1 = 4, 5, or 6, and either /P-CL (/SPD-A) or /N-CL (SPD-B) is OFF (high level), the control mode will switch.

Example:

When Pn000.1=5: Internally set speed selection ↔ Position control (pulse train)

Input Signal		Speed
/P-CL (/SPD-A)	/N-CL (/SPD-B)	
OFF (high)	OFF (high)	Pulse train reference input (position control)
OFF (high)	ON (low)	Pn301: Internally Set Speed 1 (SPEED1)
ON (low)	ON (low)	Pn302: Internally Set Speed 2 (SPEED2)
ON (low)	OFF (high)	Pn303: Internally Set Speed 3 (SPEED3)

• Example of Operating with Internally Set Speed Selection

The shock that results when the speed is changed can be reduced by using the soft start function. For details on the soft start function, refer to 8.5.4 Soft Start.

Example: Operation with an Internally Set Speed and Soft Start

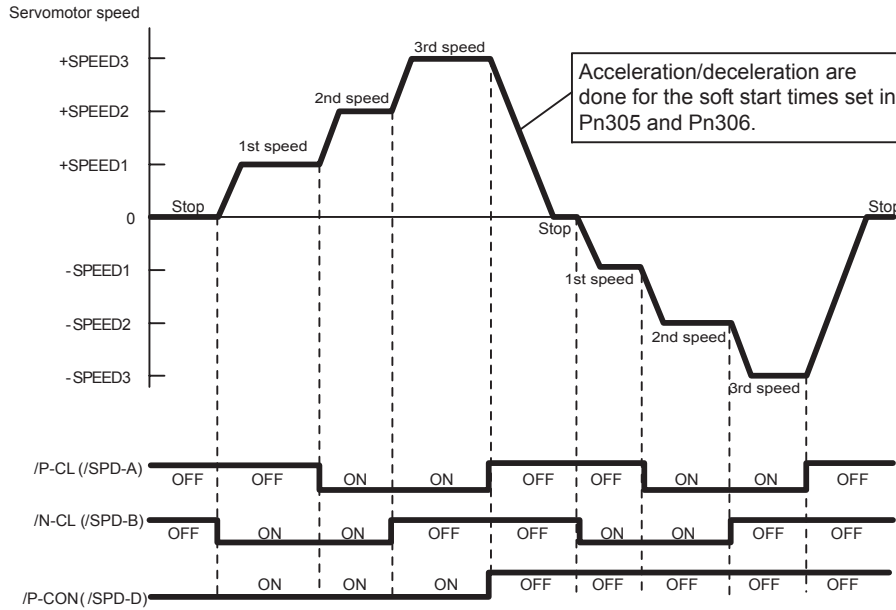

IMPORTANT

When Pn000.1 = 5 (Internally set speed control ↔ Position control in the SGDJ-□□□P SERVOPACK), the soft start function will operate only when selecting the internally set speed. The soft start function cannot be used with pulse reference input. When switching to pulse reference input during operation at either of the three speeds (1st speed to 3rd speed), the pulse reference will not be received by the SERVOPACK until after the positioning completed (/COIN) signal is output. Always begin the output of the pulse reference from the host controller after the positioning completed (/COIN) signal is output from the SERVOPACK.

Example: Operation with an Internally Set Speed and Soft Start ↔ Position Control (Pulse Train Reference)

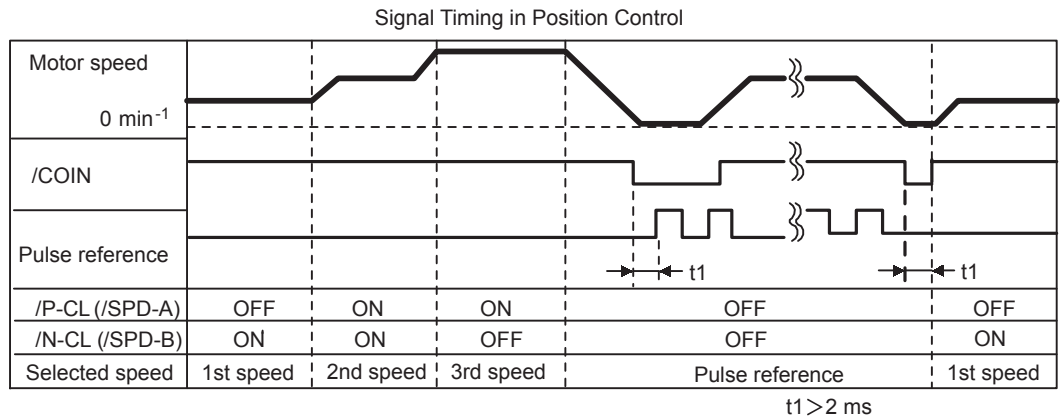

- Note: 1. The soft start function is used in the above figure.
 2. The t_1 value is not affected by whether the soft start function is used.
 A maximum delay of 2 ms occurs in loading /P-CL (/SPD-A) and /N-CL (/SPD-B).

8.9 Limiting Torque

The SERVOPACK provides the following four methods for limiting output torque to protect the machine.

Setting Level	Limiting Method	Applicable SERVOPACK SGDJ-		Reference Section
		□□□S	□□□P	
1	Internal torque limit	Applicable	Applicable	8.9.1
2	External torque limit	Applicable	Applicable	8.9.2
3	Torque limiting by analog voltage reference	Applicable	N/A	8.9.3
4	External torque limit + Torque limiting by analog voltage reference	Applicable	N/A	8.9.4

8.9.1 Internal Torque Limit (Limiting Maximum Output Torque)

Maximum torque is always limited to the values set in the following parameters.

Pn402	Forward Torque Limit			<input type="checkbox"/> Speed	<input type="checkbox"/> Position	<input type="checkbox"/> Torque
	Setting Range	Setting Unit	Factory Setting	Setting Validation		
	0 to 800	%	800	Immediately		
Pn403	Reverse Torque Limit			<input type="checkbox"/> Speed	<input type="checkbox"/> Position	<input type="checkbox"/> Torque
	Setting Range	Setting Unit	Factory Setting	Setting Validation		
	0 to 800	%	800	Immediately		

The settings in these parameters are constantly enabled. The setting unit is a percentage of rated torque.

If the torque limit is set higher than the maximum torque of the servomotor, the maximum torque of the servomotor is used (as is the case with the 800% factory setting).

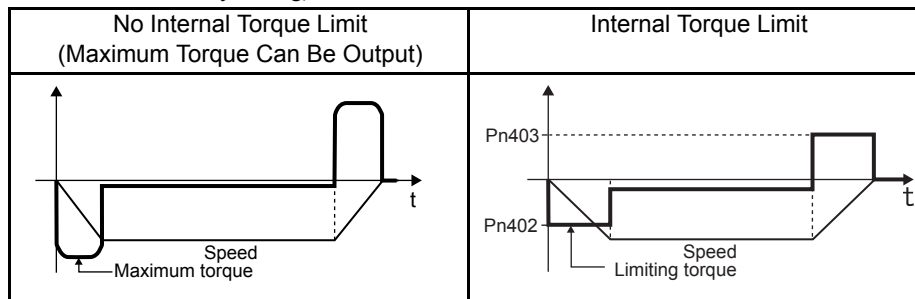

Too small a torque limit setting will result in insufficient torque during acceleration and deceleration.

8.9.2 External Torque Limit (Output Torque Limiting by Input Signals)

This function allows the torque to be limited at specific times during machine operation, for example, during press stops and hold operations for robot workpieces.

An input signal is used to enable the torque limits previously set in parameters.

(1) Related Parameters

Pn404	Forward External Torque Limit			<input type="checkbox"/> Speed	<input type="checkbox"/> Position	<input type="checkbox"/> Torque
	Setting Range	Setting Unit	Factory Setting	Setting Validation		
	0 to 800	%	100	Immediately		
Pn405	Reverse External Torque Limit			<input type="checkbox"/> Speed	<input type="checkbox"/> Position	<input type="checkbox"/> Torque
	Setting Range	Setting Unit	Factory Setting	Setting Validation		
	0 to 800	%	100	Immediately		

Note: The setting unit is a percentage of rated torque (i.e., the rated torque is 100%).

(2) Input Signals

Type	Signal Name	Connector Pin Number	Setting	Meaning	Limit Value
Input	/P-CL	CN1-11 (Factory Setting)	ON (low level)	Forward external torque limit ON	The value set in Pn402 or Pn404 (whichever is smaller)
			OFF (high level)	Forward external torque limit OFF	Pn402
Input	/N-CL	CN1-12 (Factory Setting)	ON (low level)	Reverse external torque limit ON	The value set in Pn403 or Pn405 (whichever is smaller)
			OFF (high level)	Reverse external torque limit OFF	Pn403
When using this function, make sure that there are no other signals allocated to the same terminals as /P-CL and /N-CL. When multiple signals are allocated to the same terminal, the signals are handled with OR logic, which affects the ON/OFF state of the other signals. Refer to 7.3.2 <i>Input Circuit Signal Allocation</i> .					

(3) Changes in Output Torque during External Torque Limiting

Example: External torque limit (Pn402, Pn403) set to 800%

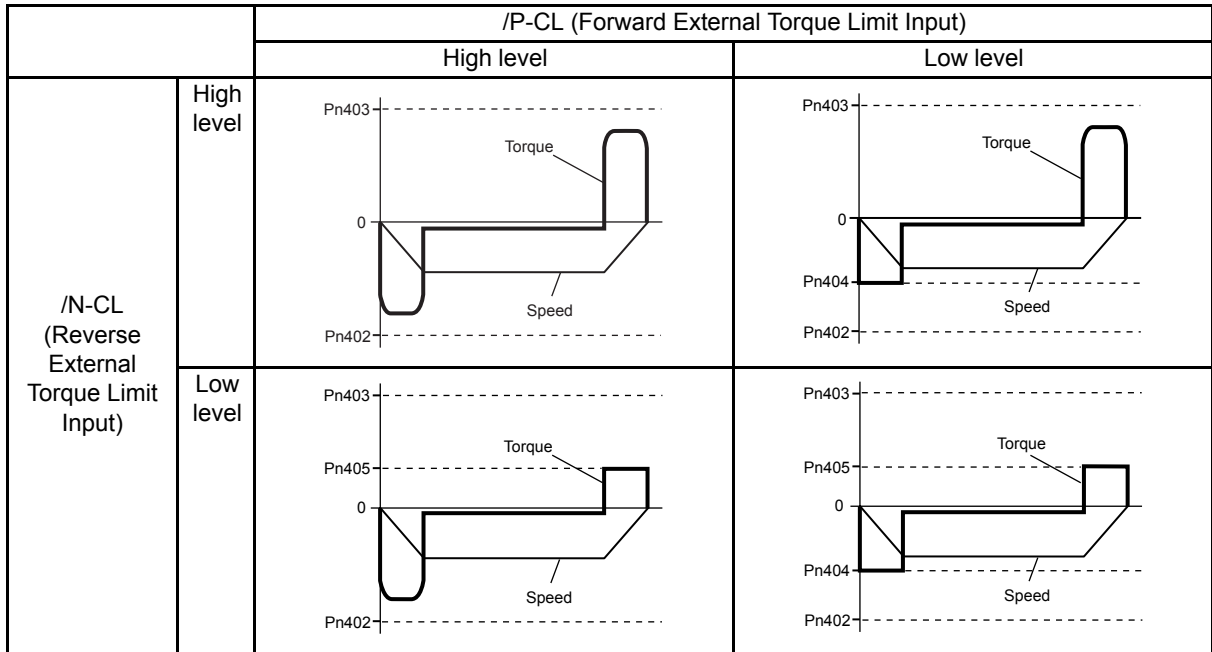

Note: In this example, the servomotor rotation direction is Pn000 = n.□□□0 (standard setting, CCW = forward).

8.9.3 Torque Limiting Using an Analog Voltage Reference

Torque limiting by analog voltage reference limits torque by assigning a torque limit in an analog voltage to the T-REF terminals (CN1-1 and 2) in the SGDJ-□□□S SERVOPACK. This function can be used only with the speed control in the SGDJ-□□□S SERVOPACK and not with the torque control.

Refer to the following block diagram when the torque limit with an analog voltage reference is used for speed control.

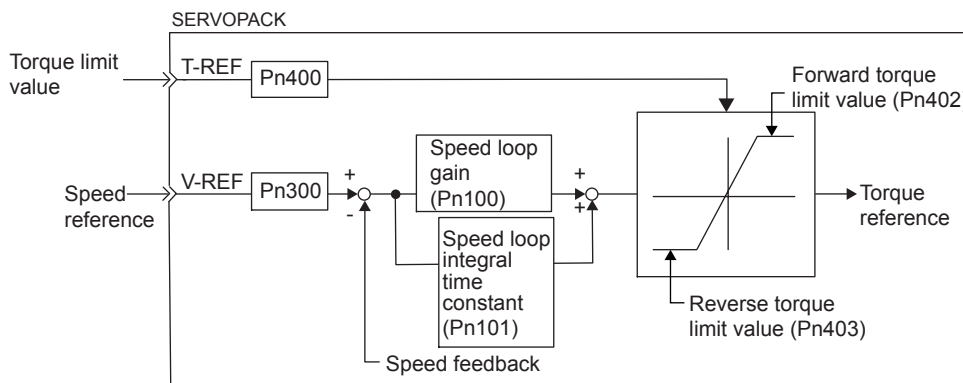

There is no polarity in the input voltage of the analog voltage reference for torque limiting. The absolute values of both + and - voltages are input, and a torque limit value corresponding to that absolute value is applied in the forward or reverse direction.

(1) Related Parameters

Parameter	Meaning
Pn002 n.□□□1	Speed control option: Uses the T-REF terminal to be used as an external torque limit input.
When n.□□□2 is set, the T-REF terminal is used for torque feed-forward input, but the functions cannot be used together.	

(2) Input Signals

Type	Signal Name	Connector Pin Number	Name
Input	T-REF	CN1-1	Torque reference input
	SG	CN1-2	Signal ground for torque reference input

The torque limit input gain is set at parameter Pn400. Refer to 8.7.1 *Setting Parameters*.

■ Input Specifications

- Input range: ± 1 VDC to ± 10 VDC/rated torque
- Maximum allowable input voltage: ± 12 VDC

8.9.4 Torque Limiting Using an External Torque Limit and Analog Voltage Reference

This function can be used to combine torque limiting by an external input signal and by analog voltage reference and can be used only for SGDJ-□□□S SERVOPACK. Because the torque limit by analog voltage reference is input from T-REF (CN1-1, 2), this function cannot be used during torque control. Use /P-CL (CN1-11) or /N-CL (CN1-12) for torque limiting by external input signal.

When /P-CL (or /N-CL) is ON, either the torque limit by analog voltage reference or the setting in Pn404 (or Pn405) will be applied as the torque limit, whichever is smaller.

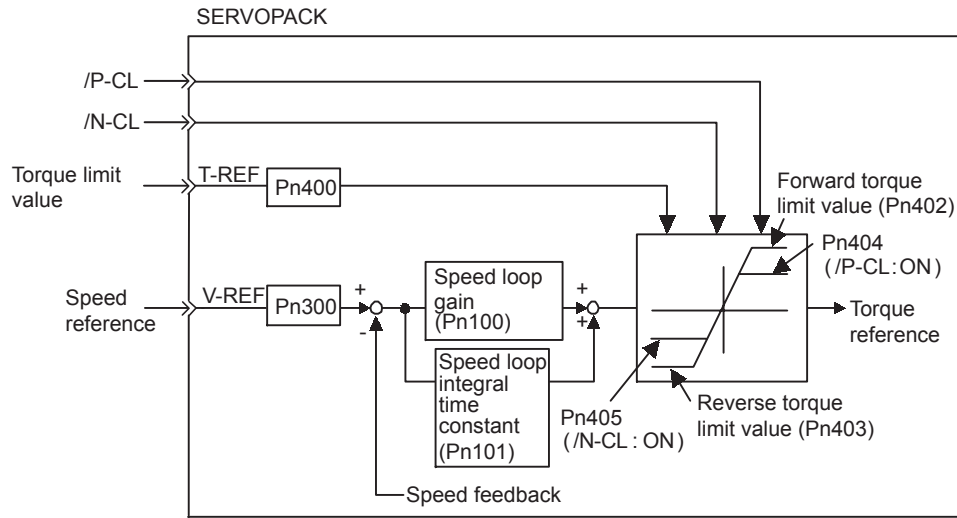

(1) Related Parameters

Parameter	Meaning
Pn002 n.□□□3	Speed control option: When /P-CL or /N-CL is enabled, the T-REF terminal is used as the external torque limit input.
When n.□□□2 is set, T-REF is used for torque feed-forward input, but the functions cannot be used together.	

Pn404	Forward External Torque Limit	<input type="checkbox"/> Speed	<input type="checkbox"/> Position	<input type="checkbox"/> Torque
	Setting Range	Setting Unit	Factory Setting	Setting Validation
	0 to 800	%	100	Immediately
Pn405	Reverse External Torque Limit			
	Setting Range	Setting Unit	Factory Setting	Setting Validation
	0 to 800	%	100	Immediately

* The setting unit is a percentage of rated torque (i.e., the rated torque is 100%).

(2) Input Signals

Type	Signal Name	Connector Pin Number	Name
Input	T-REF	CN1-1	Torque reference input
	SG	CN1-2	Signal ground for torque reference input
<p>The torque limit input gain is set in parameter Pn400. Refer to 8.7.1 <i>Setting Parameters</i>.</p> <p>■ Input Specifications</p> <ul style="list-style-type: none"> • Input range: ± 1 VDC to ± 10 VDC/rated torque • Maximum allowable input voltage: ± 12 VDC 			

Type	Signal Name	Connector Pin Number	Setting	Meaning	Limit Value
Input	/P-CL	CN1-11 (Factory setting)	ON (low level)	Forward external torque limit ON	The analog voltage reference limit or the value set in Pn402 or Pn404 (whichever is smaller)
			OFF (high level)	Forward external torque limit OFF	Pn402
Input	/N-CL	CN1-12 (Factory setting)	ON (low level)	Reverse external torque limit ON	The analog voltage reference limit or the value set in Pn403 or Pn405 (whichever is smaller)
			OFF (high level)	Reverse external torque limit OFF	Pn403
<p>When using the torque limiting with the external torque limit and analog voltage reference, make sure that there are no other signals allocated to the same terminals as /P-CL and /N-CL. When multiple signals are allocated to the same terminal, the signals are handled with OR logic, which affects the ON/OFF state of the other signals. Refer to 7.3.2 <i>Input Circuit Signal Allocation</i>.</p>					

8.9.5 Checking Output Torque Limiting during Operation

The following signal can be output to indicate that the servomotor output torque is being limited.

Type	Signal Name	Connector Pin Number	Setting	Meaning
Output	/CLT	Must be allocated	ON (low level)	Servomotor output torque is being limited.
			OFF (high level)	Torque is not being limited.
<p>The output terminal must be allocated with parameter Pn50F to use this output signal. Refer to 7.3.3 <i>Output Circuit Signal Allocation</i> for details.</p>				

8.10 Control Mode Selection

The methods and conditions for switching SERVOPACK control modes are described below.

8.10.1 Setting Parameters

The following combinations of control modes can be selected according to the application at hand.

Parameter	Control Method	Applicable SERVOPACK	
		SGDJ-□□□S	SGDJ-□□□P
Pn000	n.□□4□ Internally set speed control (contact reference) ↔ Speed control (analog voltage reference)	Applicable	N/A
	n.□□5□ Internally set speed control (contact reference) ↔ Position control (pulse train reference)	N/A	Applicable
	n.□□6□ Internally set speed control (contact reference) ↔ Torque control (analog voltage reference)	Applicable	N/A
	n.□□7□ Reserved	N/A	N/A
	n.□□8□ Reserved	N/A	N/A
	n.□□9□ Torque control (analog voltage reference) ↔ Speed control (analog voltage reference)	Applicable	N/A
	n.□□A□ Speed control (analog voltage reference) ↔ Zero clamp	Applicable	N/A
	n.□□B□ Position control (pulse train reference) ↔ Position control (inhibit)	N/A	Applicable

8.10.2 Switching the Control Mode

(1) Switching Internally Set Speed Control (Pn000.1 = 4, 5, or 6)

With the sequence input signals in the factory setting (Pn50A = n.□□□0), the control mode will switch when both /P-CL (/SPD-A) and /N-CL (/SPD-B) signals are OFF (high level).

Type	Signal Name	Connector Pin Number	Setting	Meaning
Input	/P-CL	CN1-11 (Factory setting)	OFF (high level)	Switches control mode.
	(/SPD-A)	Must be allocated		
Input	/N-CL	CN1-12 (Factory setting)	OFF (high level)	
	(/SPD-B)	Must be allocated		
<p>■ Input Signal Selection</p> <p>The following two types of control mode selection are available for switching from internally set speed control:</p> <ul style="list-style-type: none"> • Switching with the /P-CL and /N-CL input signals (pins allocated in factory setting) • Switching with the /SPD-A and /SPD-B input signals <p>When using /SPD-A and /SPD-B, they must be allocated with parameter Pn50C. Refer to 7.3.2 <i>Input Circuit Signal Allocation</i>.</p>				

(2) Switching Other Than Internally Set Speed Control (Pn000.1 = 9, A, or B)

Use the following signals to switch control modes. The control modes switch as shown below for each of the signal states indicated.

When changing the sequence input signal from the factory setting (Pn50A = n.□□□1), allocate the /C-SEL to an input terminal and change modes with the /C-SEL signal. In this case, input a speed reference (analog voltage reference) for speed control, and a position reference (pulse train reference) for position control.

Type	Signal Name	Connector Pin Number	Setting	Pn000 Setting		
				n.□□9□	n.□□A□	n.□□B□
Input	/P-CON	CN1-15 (Factory setting)	ON (low level)	Speed	Zero clamp	Inhibit
			OFF (high level)	Torque	Speed	Position
(Input)	(/C-SEL)	Must be allocated	ON (low level)	Speed	Zero clamp	Inhibit
			OFF (high level)	Torque	Speed	Position
The control mode can be switched with either /P-CON or /C-SEL. When using the /C-SEL signal, the input signal must be allocated. Refer to 7.3.2 <i>Input Circuit Signal Allocation</i> .						

8.11 Other Output Signals

The following output signals, which have no direct connection with the control modes, are used for machine protection.

8.11.1 Servo Alarm Output (ALM) and Alarm Code Output (ALO1, ALO2, ALO3)

(1) Servo Alarm Output (ALM)

This signal is output when an error is detected in the SERVOPACK.

Type	Signal Name	Connector Pin Number	Setting	Meaning
Output	ALM	CN1-34, 35 (Factory setting)	ON (low level)	Normal SERVOPACK condition
			OFF (high level)	SERVOPACK alarm condition
<p>■ IMPORTANT</p> <p>Always form an external circuit so this alarm output turns OFF the main circuit power supply to the SERVOPACK.</p>				

(2) Alarm Reset

Type	Signal Name	Connector Pin Number	Name
Input	/ALM-RST	CN1-18	Alarm Reset
<p>When a servo alarm (ALM) has occurred and the cause of the alarm has been eliminated, the alarm can be reset by turning this signal (/ALM-RST) from OFF (high level) to ON (low level).</p> <p>This signal can be allocated to other pin numbers with Pn50B.</p> <p>For details on the procedure, refer to <i>7.3.2 Input Circuit Signal Allocation</i>.</p> <p>The /ALM-RST signal cannot be constantly enabled by the allocation of an external input signal. Reset the alarm by changing the signal from high level to low level. The alarm can also be reset from the panel operator or digital operator. Refer to <i>7.1.2 Key Names and Functions</i> for details.</p>			

IMPORTANT

1. Some encoder-related alarms cannot be reset with the /ALM-RST signal input. To reset these alarms, turn OFF the control power supply.
2. When an alarm occurs, always eliminate the cause before resetting the alarm. The methods for troubleshooting alarms are described in *10.1.3 Troubleshooting of Alarm and Warning*.

(3) Alarm Code Output

Type	Signal Name	Connector Pin Number	Meaning
Output	ALO1	CN1-30	Alarm code output
Output	ALO2	CN1-31	Alarm code output
Output	ALO3	CN1-32	Alarm code output
Output	SG	CN1-33	Signal ground for alarm code output
<p>These open-collector signals output alarm codes. The ON/OFF combination of these output signals indicates the type of alarm detected by the servomotor.</p> <p>Use these signals to display alarm codes at the host controller. Refer to <i>10.1.1 Alarm Display Table</i> for details on alarm code output.</p>			

8.11.2 Warning Output (/WARN)

Type	Signal Name	Connector Pin Number	Setting	Meaning
Output	/WARN	Must be allocated	ON (high level)	Normal state
			OFF (low level)	Warning state

This output signal displays warnings before an overload (A.71) alarm is output.
For use, the /WARN signal must be allocated with parameter Pn50F. For details, refer to 7.3.3 *Output Circuit Signal Allocation*.

- **Related Parameters**

The following parameter is used to select the alarm code output.

Parameter	Description
Pn001 n.0□□□	Outputs alarm codes alone for alarm codes ALO1, ALO2, and ALO3.
n.1□□□	Outputs both alarm and warning codes for alarm codes ALO1, ALO2, and ALO3, and outputs an alarm code when an alarm occurs.

- Refer to 8.11.1 *Servo Alarm Output (ALM) and Alarm Code Output (ALO1, ALO2, ALO3)* for alarm code descriptions.
- Refer to 10.1.2 *Warning Display* for the ON/OFF combinations of ALO1, ALO2, and ALO3 when a warning code is output.

8.11.3 Running Output Signal (/TGON)

Type	Signal Name	Connector Pin Number	Setting	Meaning
Output	/TGON	CN1-9, 10 (Factory setting)	ON (low level)	Servomotor is operating (Motor speed is above the setting in Pn502).
			OFF (high level)	Servomotor is not operating (Motor speed is below the setting in Pn502).

This signal is output to indicate that the servomotor is currently operating above the setting in parameter Pn502.
The /TGON signal can be allocated to another output terminal with parameter Pn50E. For details, refer to 7.3.3 *Output Circuit Signal Allocation*.

■ **IMPORTANT**

- If the brake signal (/BK) and running output signal (/TGON) are allocated to the same output terminal, the /TGON signal will go to low level at the speed at which the movable part drops on the vertical axis, which means that the /BK signal will not go to high level. (This is because signals are output with OR logic when multiple signals are allocated to the same output terminal.). Always allocate /TGON and /BK signals to different terminals.

- **Related Parameter**

Pn502	Rotation Detection Level	<input type="text" value="Speed"/>	<input type="text" value="Position"/>	<input type="text" value="Torque"/>
	Setting Range	Setting Unit	Factory Setting	Setting Validation
	1 to 10000	min ⁻¹	20	Immediately

Set the range in which the running output signal (/TGON) is output in this parameter.
When the servomotor rotation speed is above the value set in the Pn502, it is judged to be servomotor rotating and the running output signal (/TGON) is output. The rotation detection signal can also be checked on the digital operator. For details, refer to 7.1.4 *Status Display* and 7.4.1 *List of Monitor Modes*.

8.11.4 Servo Ready (/S-RDY) Output

Type	Signal Name	Connector Pin Number	Setting	Meaning
Output	/S-RDY	CN1-7, 10 (Factory setting)	ON (low level)	Servo is ready.
			OFF (high level)	Servo is not ready.
<p>This signal indicates that the SERVOPACK received the servo ON signal and completed all preparations. It is output when there are no servo alarms and the main circuit power supply is turned ON.</p> <p>An added condition with absolute encoder specifications is that when the SEN signal is at high level, absolute data was output to the host controller.</p> <p>The servo ready signal condition can also be checked on the digital operator. For details, refer to <i>7.1.4 Status Display</i> and <i>7.4.1 List of Monitor Modes</i>.</p> <p>The /S-RDY signal can be allocated to another output terminal with parameter Pn50E. For details, refer to <i>7.3.3 Output Circuit Signal Allocation</i>.</p>				

Adjustments

9.1 Autotuning	9-2
9.1.1 Servo Gain Adjustment Methods	9-2
9.1.2 List of Servo Adjustment Functions	9-3
9.2 Online Autotuning	9-5
9.2.1 Online Autotuning	9-5
9.2.2 Online Autotuning Procedure	9-6
9.2.3 Selecting the Online Autotuning Execution Method	9-7
9.2.4 Machine Rigidity Setting for Online Autotuning	9-8
9.2.5 Method for Changing the Machine Rigidity Setting	9-9
9.2.6 Saving the Results of Online Autotuning	9-10
9.2.7 Procedure for Saving the Results of Online Autotuning	9-10
9.3 Manual Tuning	9-11
9.3.1 Explanation of Servo Gain	9-11
9.3.2 Servo Gain Manual Tuning	9-12
9.3.3 Position Loop Gain	9-12
9.3.4 Speed Loop Gain	9-13
9.3.5 Speed Loop Integral Time Constant	9-13
9.4 Servo Gain Adjustment Functions	9-14
9.4.1 Feed-forward Reference	9-14
9.4.2 Torque Feed-forward	9-15
9.4.3 Proportional Control Operation (Proportional Operation Reference)	9-16
9.4.4 Using the Mode Switch (P/PI Switching)	9-17
9.4.5 Setting the Speed Bias	9-20
9.4.6 Speed Feedback Filter	9-20
9.4.7 Speed Feedback Compensation	9-21
9.4.8 Switching Gain Settings	9-23
9.4.9 Torque Reference Filter	9-24
9.5 Analog Monitor	9-26
9.5.1 Related Parameters	9-27
9.5.2 Manual Zero Adjustment and Gain Adjustment of Analog Monitor Output (Fn00C, Fn00D)	9-28

9.1 Autotuning

9.1.1 Servo Gain Adjustment Methods

The SERVOPACK has the servo gains to determine the servo response characteristics. The servo gains are set in the parameters. The parameters are designated for each function as shown in *9.1.2 List of Servo Adjustment Functions*.

The servo gains are factory-set to stable values, and responsiveness can be increased depending on the actual machine conditions. The following flowchart shows an overview procedure for adjusting the servo gains to reduce the positioning time for position control. Follow this flowchart to effectively adjust the servo gains. For functions in bold lines in the flowchart, select the adjustment method according to the client's intent using *9.1.2 List of Servo Adjustment Functions*.

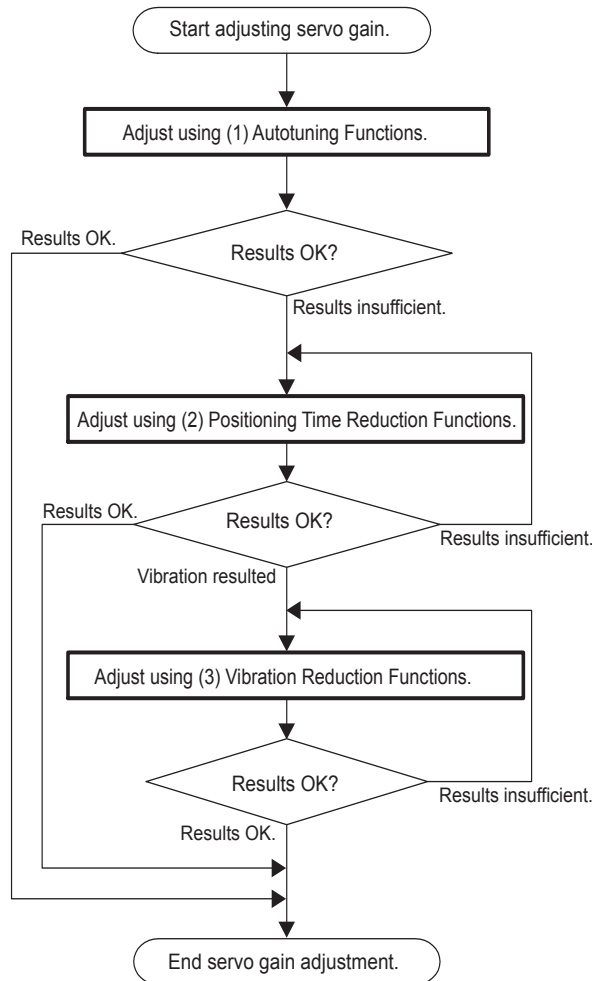

If the desired responsiveness cannot be achieved adjusting according to the servo gain adjustment methods, consider the following possible causes.

- Autotuning does not suit the operating conditions.
Adjust the servo gains manually. Refer to *9.3 Manual Tuning*.
- The selection of settings for the positioning time reduction functions or vibration reduction functions are not appropriate.
Each function may not be effective for all machines due to machine characteristics or operating conditions.
Use other positioning time reduction function or vibration reduction function.

9.1.2 List of Servo Adjustment Functions

(1) Autotuning Functions

Autotuning calculates the load moment of inertia, which determines the servo responsiveness, and automatically adjusts parameters, such as the Speed Loop Gain K_v (Pn100), Speed Loop Integral Time Constant T_i (Pn101), Position Loop Gain K_p (Pn102), and Torque Reference Filter Time Constant T_f (Pn401). Refer to the following table to select the appropriate autotuning function for your desired purpose and adjust the servo gains.

Function Name and Related Parameters	Description	Guidelines for Selection	Reference Section
Online Autotuning Pn110.0 Fn001 Fn007	This function automatically measures the machine characteristics and sets the required servo gains accordingly. This function allows beginners to adjust the servo gains easily. The load moment of inertia is calculated during operation for a user reference, and the servo gains (K_v , T_i , K_p , and T_f) are set according to the Machine Rigidity Setting (Fn001).	Only the minimum number of parameters must be set for autotuning using a normal operation reference.	9.2

(2) Positioning Time Reduction Functions

Function Name and Related Parameters	Description	Features	Valid Control Modes	Reference Section
Feed-forward Pn109 Pn10A	Feed-forward compensation for the position reference is added to the speed reference.	Adjustment is easy. The system will be unstable if a large value is set, possibly resulting in overshooting or vibration.	Position	9.4.1
Torque feed-forward Pn002 Pn400	Inputs torque feed-forward to the torque reference input terminal and adds to the internal torque reference at the speed control.		Speed	9.4.2
Mode Switch (P/PI Switching) Pn10B Pn10C Pn10D Pn10E Pn10F	Switches from PI control to P control using the value of an internal servo variable in a parameter (torque, speed, acceleration, or position error) as a threshold value.	The setting for automatic switching between PI and P control is easy.	Position Speed	9.4.4
Speed Feedback Compensation Pn110 Pn111	Compensates the motor speed using an observer.	Adjustment is easy because the compensation can be set as a percentage. If the speed loop gain increases, the position loop gain also increases, however sometimes the servo rigidity decreases.	Position Speed	9.4.7
Gain Switching Pn100 Pn101 Pn102 Pn104 Pn105 Pn106	Uses the external signals to change each parameter for speed loop gain (K_v), speed loop integral time constant (T_i), and position loop gain (K_p).	–	Position Speed	9.4.8

(3) Vibration Reduction Functions

Function Name and Related Parameters	Description	Features	Valid Control Modes	Reference Section
Soft Start Pn305 Pn306	Converts a stepwise speed reference to a constant acceleration or deceleration for the specified time interval.	A constant acceleration/deceleration is achieved for smoother operation. The operation time is increased for the specified time.	Speed	8.5.4
Acceleration/ Deceleration Filters Pn204 Pn207	A 1st-order delay filter for the position reference input.	Enables smooth operation. The reference time increases by the filter delay time even after the reference input has been completed.	Position	8.6.4
Movement Average Filter Pn207 Pn208	A movement averaging filter for the position reference input.	Enables smooth operation. The reference time increases by the filter delay time even after the reference input has been completed.	Position	8.6.4
Speed Feedback Filter Pn308	A standard 1st-order delay filter for the speed feedback.	The feedback speed is smoother. The response is delayed if a large value is set.	Position Speed	9.4.6
Speed Reference Filter Pn307	A 1st-order delay filter for the speed reference.	The speed reference is smoother. The response is delayed if a large value is set.	Speed	8.5.5
Torque Reference Filter Pn401	A series of three filter time constants, 1st-order, 2nd-order, and 1st-order, can be set in order for the torque reference.	These filters are effective in essentially all frequency bands. The response is delayed if a large value (low frequency) is set.	Position Speed Torque	9.4.9
Notch Filter Pn409	Notch filters can be set for the torque reference.	Mainly effective for vibration between 500 and 2,000 Hz. Instability will result if the setting is not correct.	Position Speed Torque	9.4.9

9.2 Online Autotuning

9.2.1 Online Autotuning

Online autotuning calculates the load moment of inertia during operation of the SERVOPACK and sets parameters so that the servo gains consistent with the Machine Rigidity (Fn001) are achieved.

Online autotuning may not be effective in the following cases.

- The load moment of inertia varies in less than 200 ms.
- The motor speed is lower than 100 min^{-1} or the acceleration reference is very even.
- Load rigidity is low and mechanical vibration occurs easily or friction is high.
- The speed reference is a stepwise reference.

If the condition meets one of the above cases or the desired operation cannot be achieved by the online autotuning, calculate the load moment of inertia on the basis of the machine specifications or using the moment of inertia detection function of Yaskawa's servodrive supporting tool "SigmaWin+". Set the value in Pn103 and perform the adjustment manually.

The following utility function is also available for the online autotuning.

Fn007: Writes the load moment of inertia calculated by the online autotuning in Pn103 and uses as the default value for the next calculation.

9.2.2 Online Autotuning Procedure

 **WARNING**

- Do not perform extreme adjustment or setting changes causing unstable servo operation. Failure to observe this warning may result in injury and damages to the machine.
- Adjust the gains slowly while confirming motor operation.

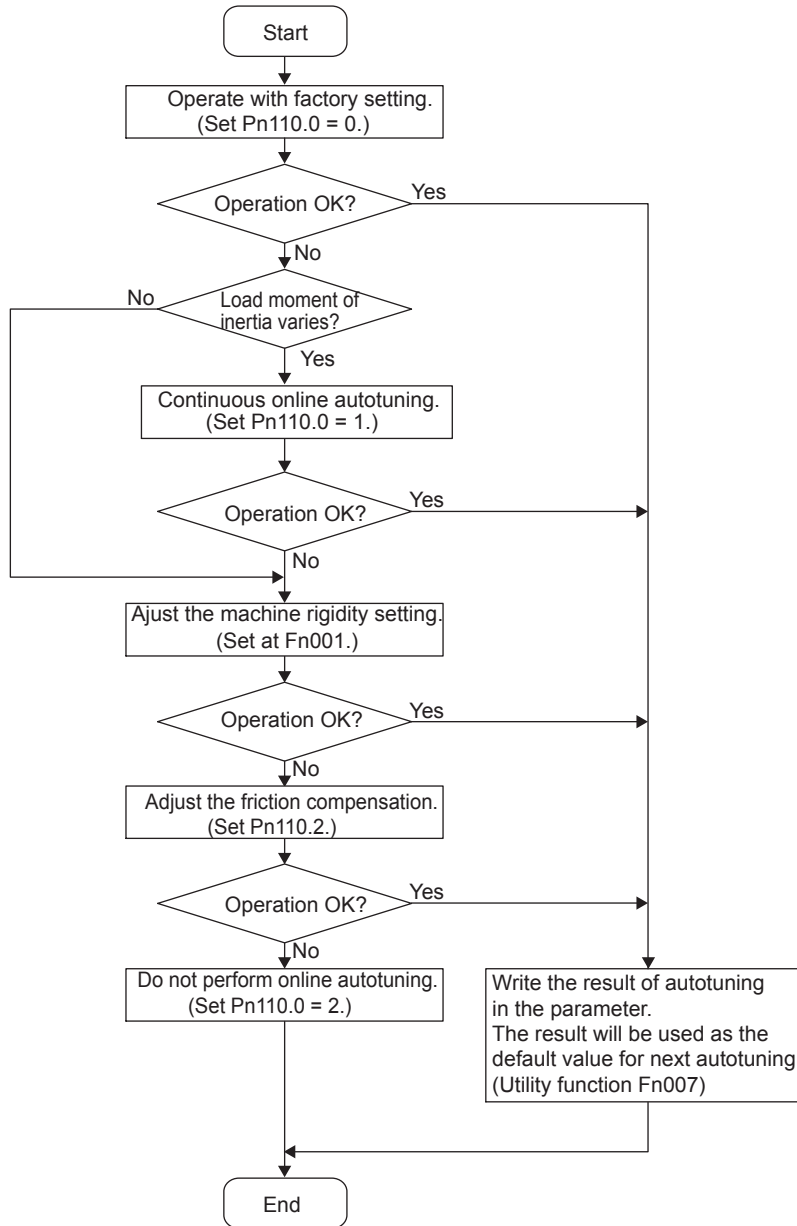

9.2.3 Selecting the Online Autotuning Execution Method

There are three methods that can be used for online autotuning: At start of operation, constantly, and none. The selection method is described next.

Pn110	Online Autotuning Switches			
			<input type="checkbox"/> Speed	<input type="checkbox"/> Position
	Setting Range	Setting Unit	Factory Setting	Setting Validation
	–	–	0010	After restart
Parameter	Meaning			
Pn110	n.□□□0	Online autotuning is performed only after the first time power is turned ON. (Factory Setting)		
	n.□□□1	Online autotuning (moment of inertia calculations) is performed continuously.		
	n.□□□2	Online autotuning is not performed.		
<p>The factory setting is n.□□□0. This setting is recommended for applications in which the load moment of inertia does not change much or if the load moment of inertia is not known. The inertia calculated at the beginning of operation is used continuously. In this case, differences in machine status and operation references at the beginning of operation may cause minor differences in the calculation results of the load moment of inertia, causing differences in the servo responsiveness each time the power supply is turned ON.</p> <p>If this occurs, overwrite the moment of inertia ratio in Pn103 using the utility function Fn007 (Writing to EEPROM moment of inertia ratio data obtained from online autotuning), and set Pn110 to n.□□□2 to disable online autotuning.</p> <p>The setting n.□□□1 is used when the load moment of inertia varies constantly. This setting enables a consistent responsiveness even when the load moment of inertia changes. If the load moment of inertia changes in less than 200 ms, however, the autotuning accuracy will deteriorate, in which case Pn110.0 should be set to 0 or 2.</p> <p>The setting n.□□□2 is used when online autotuning is not possible, when the load moment of inertia is known and the moment of inertia ratio is set in Pn103 to perform the adjustment manually, or any other time the online autotuning function is not going to be used.</p>				

9.2.4 Machine Rigidity Setting for Online Autotuning

There are ten machine rigidity settings for online autotuning. When the machine rigidity setting is selected, the servo gains (Speed Loop Gain, Speed Loop Integral Time Constant, Position Loop Gain, and Torque Reference Filter Time Constant) are determined automatically. The factory setting for the machine rigidity setting is 4. The speed loop is suitable for PI or I-P control.

When parameter Pn10B.1 is 0, PI control will be used and when Pn10B.1 is 1, I-P control will be used. To validate the setting, however, the power supply must be turned OFF and then back ON.

After having validated the setting, always set the machine rigidity setting.

When setting the machine rigidity after having changed the position loop gain (Pn102), the value closest to the set position loop gain is displayed as the initial value of machine rigidity.

- Speed Loop PI Control

Machine Rigidity Setting Fn001	Position Loop Gain [s ⁻¹] Pn102	Speed Loop Gain [Hz] Pn100	Speed Loop Integral Time Constant [0.01 ms] Pn101	Torque Reference Filter Time Constant [0.01 ms] Pn401
1	15	15	6000	250
2	20	20	4500	200
3	30	30	3000	130
4	40	40	2000	100
5	60	60	1500	70
6	85	85	1000	50
7	120	120	800	30
8	160	160	600	20
9	200	200	500	15
10	250	250	400	10

If the machine rigidity setting is greater, the servo gain will increase and positioning time will decrease. If the setting is too large, however, vibration may result depending on the machine configuration. Set the machine rigidity starting at a low value and increasing it within the range where vibration does not occur.

9.2.5 Method for Changing the Machine Rigidity Setting

The machine rigidity setting is changed in utility function mode using parameter Fn001. The procedure is given below.

Step	Display after Operation	Key	Description
1		 (DSPL/SET Key)	Press the DSPL/SET Key to select the utility function mode.
2			Press the Up or Down Cursor Key to select Fn001. *The digit that can be set will blink.
3		 (DATA/ENTER Key)	Press the DATA/ENTER Key for one second or more. The display shown at the left will appear and the rigidity for online autotuning can be set.
4			Press the Up or Down Cursor Key to select the machine rigidity setting.
5		 (DSPL/SET Key)	Press the DSPL/SET Key. The rigidity setting will be changed and “donE” will blink on the display for about one second.
6		About one second later	After “donE” is displayed, the setting will be displayed again.
7		 (DATA/ENTER Key)	Press the DATA/ENTER Key for more than one second to return to the Fn001 display of the utility function mode.

This completes changing the machine rigidity setting for online autotuning.

9.2.6 Saving the Results of Online Autotuning

CAUTION

- Always set the correct moment of inertia ratio when online autotuning is not used.
If the moment of inertia ratio is set incorrectly, vibration may occur.









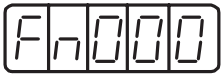

For online autotuning, the most recent load moment of inertia is calculated and the control parameters are adjusted to achieve response suitable for the machine rigidity setting. When online autotuning is performed, the Position Loop Gain (Pn102), Speed Loop Gain (Pn100), and Speed Loop Integral Time Constant (Pn101) are saved. When the power supply to the SERVOPACK is turned OFF, however, the calculated load moment of inertia is lost and the factory setting is used as the default value to start autotuning the next time the power supply is turned ON.

To use the calculated load moment of inertia as the default value the next time the power supply is turned ON, the utility function mode parameter Fn007 (Writing to EEPROM moment of inertia ratio data obtained from online autotuning) can be used to save the most recent value in parameter Pn103 (Moment of Inertia Ratio). The moment of inertia ratio is given as the moment of inertia ratio (%) of the rotor moment of inertia of the servomotor.

Pn103	Moment of Inertia Ratio			<input type="checkbox"/> Speed	<input type="checkbox"/> Position	<input type="checkbox"/> Torque
	Setting Range	Setting Unit	Factory Setting	Setting Validation		
	0 to 10,000	%	0	Immediately		
$\text{Moment of inertia ratio} = \frac{\text{Motor axis conversion load moment of inertia (J}_L\text{)}}{\text{Rotor moment of inertia (J}_M\text{)}}$ <p>The factory setting for the moment of inertia ratio is 0% (no-load operation of motor without connecting a machine).</p>						

9.2.7 Procedure for Saving the Results of Online Autotuning

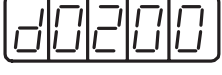
The following procedure is used to save the results of online autotuning.

Step	Display after Operation	Key	Description
1		 (DSPL/SET Key)	Press the DSPL/SET Key to select the utility function mode.
2			Press the Up or Down Cursor Key to select parameter Fn007. *The digit that can be set will blink.
3		 (DATA/ENTER Key)	Press the DATA/ENTER Key for one second or more. The display at the left will appear for a moment of inertia ratio of 200%.
4		 (DSPL/SET Key)	Press the DSPL/SET Key. The moment of inertia ratio will be saved. When completed, "donE" will blink for about one second.
5		About one second later	After "donE" is displayed, the moment of inertia ratio will be displayed again.
6		 (DATA/ENTER Key)	Press the DATA/ENTER to the Fn007 display of the utility function mode.

This completes saving the default value for the moment of inertia ratio for online autotuning. The next time the power supply is turned ON, the value that was saved for the Moment of Inertia Ratio (Pn103) will be used to start online autotuning.

9.3 Manual Tuning

9.3.1 Explanation of Servo Gain

The block diagram for position control is as follows:

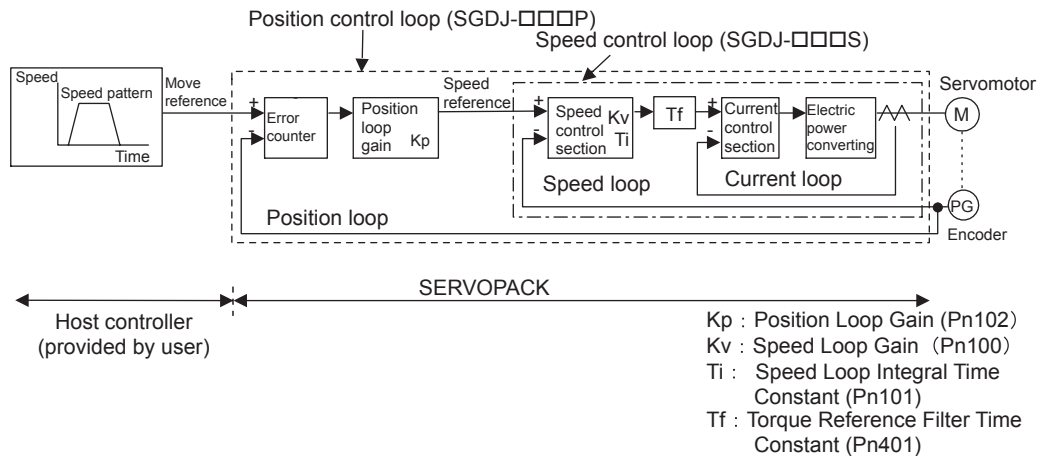

To adjust the servo gain manually, understand the configuration and characteristics of the SERVOPACK and adjust the servo gain parameters one by one. If one parameter is changed, it is almost always necessary to adjust the other parameters. It will also be necessary to make preparations such as setting up a measuring instrument to monitor the output waveform from the analog monitor.

The SERVOPACK has three feedback loops (i.e., position loop, speed loop, and current loop). The innermost loop must have the highest response and the middle loop must have higher response than the outermost. If this principle is not followed, it will result in vibration or responsiveness decreases.

The SERVOPACK is designed to ensure that the current loop has good response performance. The user need to adjust only position loop gain and speed loop gain.

9.3.2 Servo Gain Manual Tuning

The SERVOPACK has the following parameters for the servo gains. Setting the servo gains in the parameters can adjust the servo responsiveness.

- Pn100: Speed loop gain (Kv)
- Pn101: Speed loop integral time constant (Ti)
- Pn102: Position loop gain (Kp)
- Pn401: Torque reference filter time constant (Tf)

For the position and speed control, the adjustment in the following procedure can increase the responsiveness. The positioning time in position control can be reduced.

Step	Explanation
1	Set correctly the moment of inertia ratio (Pn103). The utility function Fn007 can be used after the online autotuning.
2	Increase the speed loop gain (Pn100) to within the range so that the machine does not vibrate. At the same time, decrease the speed loop integral time constant (Pn101).
3	Adjust the torque reference filter time constant (Pn401) so that no vibration occurs.
4	Repeat the steps 1 and 2. Then reduce the value for 10 to 20%.
5	For the position control, increase the position loop gain (Pn102) to within the range so that the machine does not vibrate.

Perform the manual tuning in the following cases.

- To increase the servo gains more than the values set by the online autotuning.
- To determine the servo gains and moment of inertia ratio by the user.

Start the manual tuning from the factory setting or the values set by the online autotuning. Prepare measuring instruments such as memory recorder so that the signals can be observed from the analog monitor (CN5) such as “Torque Reference” and “Motor Speed,” and “Position Error Monitor” for the position control. (Refer to 9.5 *Analog Monitor*.) The servodrive supporting tool “SigmaWin+” allows you to observe such signals. Prepare either of them.

9.3.3 Position Loop Gain

Pn102	Position Loop Gain (Kp)			
	Position			
	Setting Range	Setting Unit	Factory Setting	Setting Validation
	1 to 2,000	1/s	40	Immediately
The responsiveness of the position loop is determined by the position loop gain. The responsiveness increases and the positioning time decreases when the position loop gain is set to a higher value. In general, the position loop gain cannot be set higher than natural vibrating frequency of the mechanical system, so the mechanical system must be made more rigid to increase its natural vibrating frequency and allow the position loop gain to be set to a high value.				



If the position loop gain (Pn102) cannot be set high in the mechanical system, an overflow alarm may occur during high speed operation. In this case, increase the values in the following parameter to suppress detection of the overflow alarm.

Pn505	Overflow Level			
	Position			
	Setting Range	Setting Unit	Factory Setting	Setting Validation
	1 to 32,767	256 reference units	1,024	Immediately
This parameter's new setting must satisfy the following condition.				
$Pn505 \geq \frac{\text{Max. feed speed (reference units/s)}}{Pn102} \times 2.0$				

9.3.4 Speed Loop Gain

Pn100	Speed Loop Gain (Kv)			Speed	Position
	Setting Range	Setting Unit	Factory Setting	Setting Validation	
	1 to 2,000	Hz	40	Immediately	
<p>This parameter determines the responsiveness of the speed loop. If the speed loop's responsiveness is too low, it will delay the outer position loop and cause overshooting and vibration of the speed reference. The SERVOPACK will be most stable and responsive when the speed loop gain is set as high as possible within the range that does not cause vibration in the mechanical system. The value of speed loop gain is the same as the set value of Pn100 if the moment of inertia ratio in Pn103 has been set correctly.</p>					

Pn103	Moment of Inertia Ratio			Speed	Position	Torque
	Setting Range	Setting Unit	Factory Setting	Setting Validation		
	0 to 10,000	%	0	Immediately		
$\text{Pn103setvalue} = \frac{\text{Motor axis conversion load moment of inertia } (J_L)}{\text{Servomotor rotor moment of inertia } (J_M)} \times 100(\%)$ <p>The factory setting is Pn103=0. Before adjusting the servo, determine the moment of inertia ratio with the equation above and set parameter Pn103.</p>						

9.3.5 Speed Loop Integral Time Constant

Pn101	Speed Loop Integral Time Constant (Ti)			Speed	Position
	Setting Range	Setting Unit	Factory Setting	Setting Validation	
	15 to 51,200 (0.15 to 512.00 ms)	0.01 ms	2,000 (20.00 ms)	Immediately	
<p>The speed loop has an integral element so that the speed loop can respond to minute inputs. This integral element causes a delay in the SERVOPACK. If the time constant is set too long, overshooting will occur, which results in a longer positioning settling time or responsiveness decreases.</p> <p>The estimated set value for Pn101 depends on the speed loop control method with Pn10B.1, as shown below.</p>					



■ Selecting the Speed Loop Control Method (PI Control or I-P Control)

Generally, I-P control is more effective in high-speed positioning or high-speed/precision manufacturing applications. The position loop gain is lower than it would be in PI control, so shorter positioning times and smaller arc radii can be achieved. On the other hand, PI control is generally used when switching to P control fairly often with a mode switch or other method.

9.4 Servo Gain Adjustment Functions

9.4.1 Feed-forward Reference

Pn109	Feed-forward Position			
	Setting Range	Setting Unit	Factory Setting	Setting Validation
	0 to 100	%	0	Immediately
Pn10A	Feed-forward Filter Time Constant Position			
	Setting Range	Setting Unit	Factory Setting	Setting Validation
	0 to 6,400 (0.00 to 64.00 ms)	0.01ms	0	Immediately
<p>Applies feed-forward compensation in position control inside the SERVOPACK. Use this parameter to shorten positioning time. Too high value may cause the machine to vibrate. For ordinary machines, set 80% or less in this parameter.</p>				

9.4.2 Torque Feed-forward

Parameter	Meaning	
Pn002	n.□□□0	Disabled
	n.□□□2	Uses T-REF terminal for torque feed-forward input.

Pn400	Torque Reference Input Gain			Speed
	Setting Range	Setting Unit	Factory Setting	Setting Validation
	10 to 100 (1.0 to 10.0 V/rated torque)	0.1 V/rated torque	30 (3.0 V/rated torque)	Immediately

The torque feed-forward function is valid only in speed control (analog reference).
 The torque feed-forward function shortens positioning time, differentiates a speed reference at the host controller to generate a torque feed-forward reference, and inputs the torque feed-forward reference together with the speed reference to the SERVOPACK.
 Too high a torque feed-forward value will result in overshooting or undershooting. To prevent such troubles, set the optimum value while observing the system responsiveness.
 Connect a speed reference signal line to V-REF (CN1-3 and -4) and a torque forward-feed reference to T-REF (CN1-1 and -2) from the host controller.

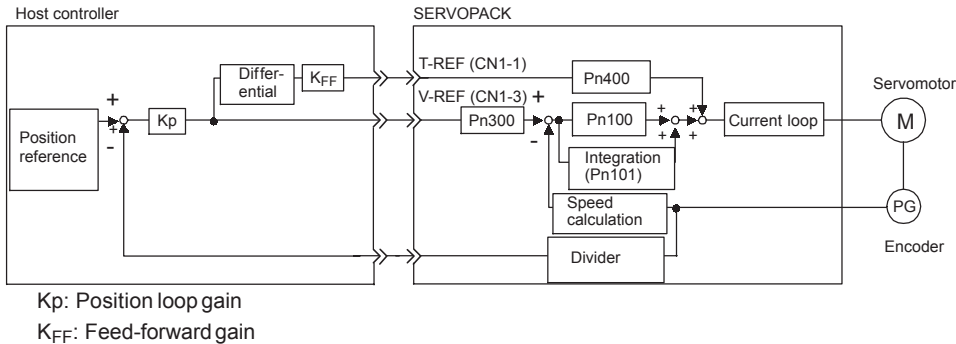

Torque feed-forward is set using the parameter Pn400.
 The factory setting is Pn400 = 30. If, for example, the torque feed-forward value is ±3V, then, the torque is limited to ±100% of the rated torque.
 The torque feed-forward function cannot be used with torque limiting by analog voltage reference described in 8.9.3 *Torque Limiting Using an Analog Voltage Reference*.

9.4.3 Proportional Control Operation (Proportional Operation Reference)

If parameter Pn000.1 is set to 0 or 1 as shown below, the /P-CON input signal serves as switch to change between PI control and P control.

- PI control: Proportional/Integral control
- P control: Proportional control

Parameter		Control Mode					
Pn000	n.□□0□	Speed Control	Effective in speed control or position control. Input signal /P-CON (CN1-15) is used to select PI control or P control.				
	n.□□1□	Position Control	<table border="1"> <tr> <td>CN1-15 is OFF (H level).</td> <td>PI control</td> </tr> <tr> <td>CN1-15 is ON (L level).</td> <td>P control</td> </tr> </table>	CN1-15 is OFF (H level).	PI control	CN1-15 is ON (L level).	P control
CN1-15 is OFF (H level).	PI control						
CN1-15 is ON (L level).	P control						
<ul style="list-style-type: none"> • When sending references from the host controller to the SERVOPACK, P control mode can be selected from the host controller for particular operating conditions. This mode switching method can be used to suppress overshooting and shorten the settling time. Refer to 9.4.4 <i>Using the Mode Switch (P/PI Switching)</i> for more details on inputting the /P-CON signal and switching the control mode for particular operating conditions. • If PI control mode is being used and the speed reference has a reference offset, the servomotor may rotate very slowly and fail to stop even if 0 is specified as the speed reference. In this case, use P control mode to stop the servomotor. 							

9.4.4 Using the Mode Switch (P/PI Switching)

Use the mode switch (P/PI switching) function in the following cases:

- To suppress overshooting during acceleration or deceleration (for speed control)
- To suppress undershooting during positioning and reduce the settling time (for position control)

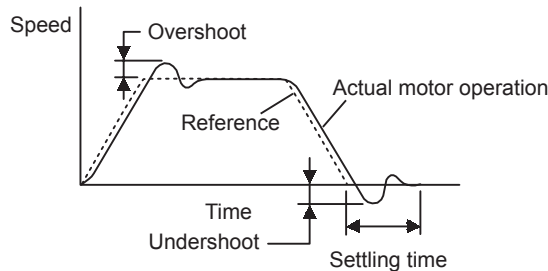

The mode switch function automatically switches the speed control mode from PI control mode to P control mode based on a comparison between the servo's internal value and a user-set detection level.

IMPORTANT

1. The mode switch function is used in very high-speed positioning when it is necessary to use the servodrive near the limits of its capabilities. The speed response waveform must be observed to adjust the mode switch.
2. For normal use, the speed loop gain and position loop gain set by autotuning provide sufficient speed/position control. Even if overshooting or undershooting occur, they can be suppressed by setting the host controller's acceleration/deceleration time constant, the SERVOPACK's Soft Start Acceleration/Deceleration Time (Pn305, Pn306), or Position Reference Acceleration/Deceleration Time Constant (Pn204).

(1) Selecting the Mode Switch Setting

The SERVOPACK provides the following four mode switch settings (0 to 3). Select the appropriate mode switch setting with parameter Pn10B.0.

Parameter	Mode Switch Selection	Parameter Containing Detection Point Setting	Setting Unit
Pn10B	n.□□□0	Use a torque reference level for detection point. (Factory Setting)	Pn10C Percentage to the rated torque
	n.□□□1	Use a speed reference level for detection point.	Pn10D Servomotor speed: min ⁻¹
	n.□□□2	Use an acceleration level for detection point.	Pn10E Servomotor acceleration: 10 min ⁻¹ /s
	n.□□□3	Use a position error pulse for detection point.	Pn10F Reference unit
	n.□□□4	Do not use the mode switch function.	– –

Select a condition to execute the mode switch (P/PI switching). (Setting is validated immediately.)



From PI control to P control

PI control means proportional/integral control and P control means proportional control. In short, switching “from PI control to P control” reduces effective servo gain, making the SERVOPACK more stable.

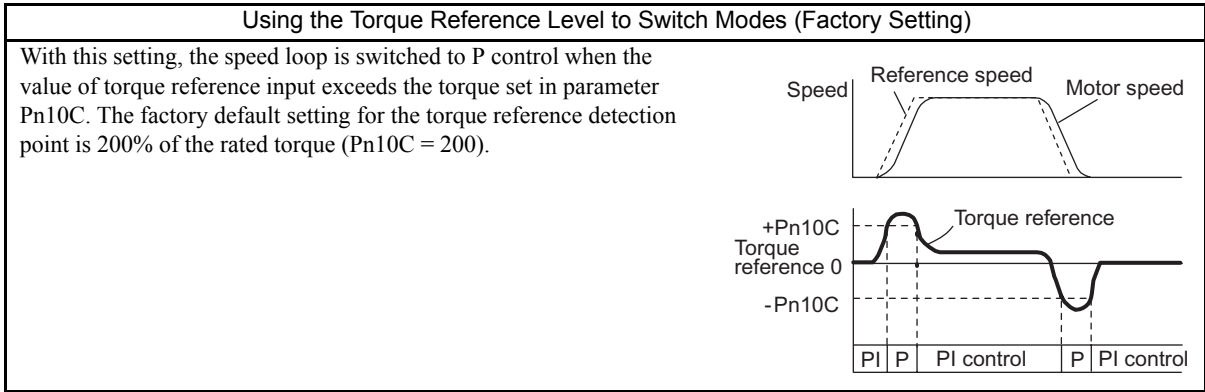

■ Operating Example

If the mode switch function is not being used and the SERVOPACK is always operated with PI control, the speed of the motor may overshoot or undershoot due to torque saturation during acceleration or deceleration. The mode switch function suppresses torque saturation and eliminates the overshooting or undershooting of the motor speed.

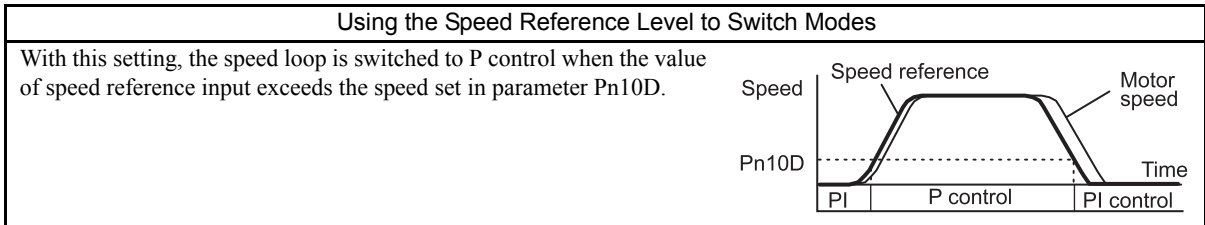
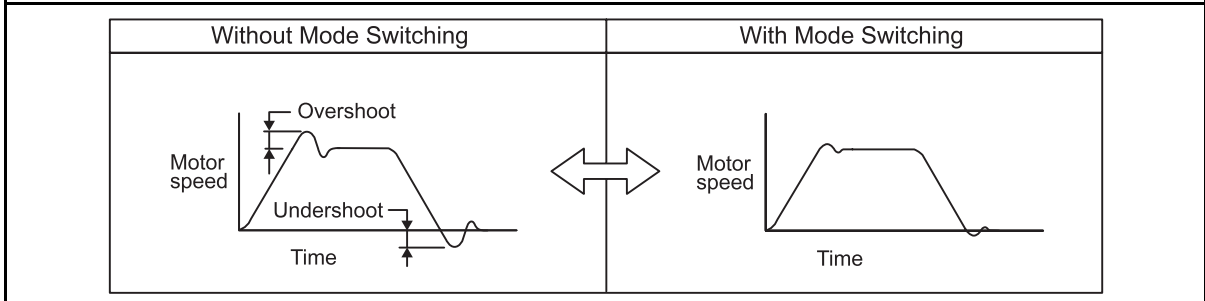

■ Operating Example

In this example, the mode switch is used to reduce the settling time. It is necessary to increase the speed loop gain to reduce the settling time. Using the mode switch suppresses overshooting and undershooting when speed loop gain is increased.

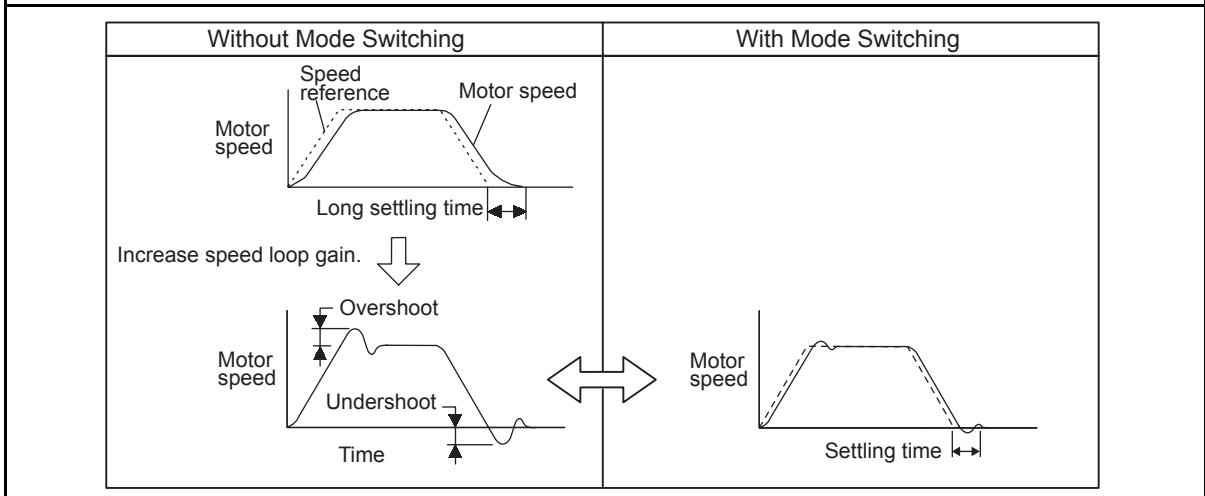

Using the Acceleration Level to Switch Modes

With this setting, the speed loop is switched to P control when the motor's acceleration rate exceeds the acceleration rate set in parameter Pn10E.

PI	P	PI control	P	PI control
----	---	------------	---	------------

Operating Example

If the mode switch function is not being used and the SERVOPACK is always operated with PI control, the speed of the motor may overshoot or undershoot due to torque saturation during acceleration or deceleration. The mode switch function suppresses torque saturation and eliminates the overshooting or undershooting of the motor speed.

Without Mode Switching	With Mode Switching

Using the Error Pulse Level to Switch Modes

This setting is effective with position control only.

With this setting, the speed loop is switched to P control when the error pulse exceeds the value set in parameter Pn10F.

PI	P control	PI control
----	-----------	------------

Operating Example

In this example, the mode switch is used to reduce the settling time. It is necessary to increase the speed loop gain to reduce the settling time. Using the mode switch suppresses overshooting and undershooting when speed loop gain is increased.

Without Mode Switching	With Mode Switching
<p>Long settling time</p>	
<p>Increase speed loop gain.</p>	<p>Settling time</p>

9.4.5 Setting the Speed Bias

The settling time for positioning can be reduced by setting the following parameters to add bias in the speed reference block in the SERVOPACK.

Pn107	Bias	Position		
	Setting Range	Setting Unit	Factory Setting	Setting Validation
	0 to 450	min ⁻¹	0	Immediately
Pn108	Bias Width Addition	Position		
	Setting Range	Setting Unit	Factory Setting	Setting Validation
	0 to 250	Reference units	7	Immediately

To reduce the positioning time, set these parameters based on the machine's characteristics.

The Bias Width Addition (Pn108) specifies when the Bias (Pn107) is added and the width is expressed in error pulse units. The bias input will be added when the error pulse value exceeds the width set in Pn108.

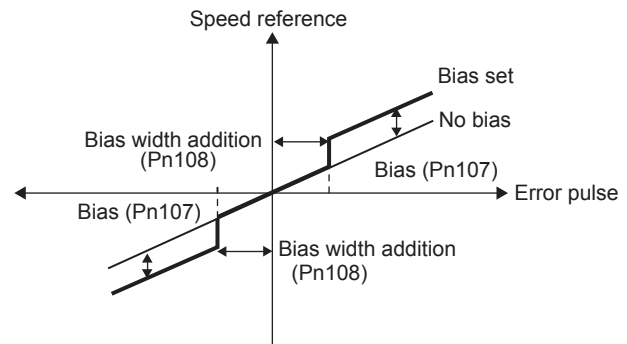

9.4.6 Speed Feedback Filter

Pn308	Speed Feedback Filter Time Constant	Speed		Position
	Setting Range	Setting Unit	Factory Setting	Setting Validation
	0 to 65,535 (0.00 to 655.35 ms)	0.01 ms	0 (0.00 ms)	Immediately
Sets the 1st-order filter for the speed loop's speed feedback. Makes the motor speed smoother and reduces vibration. If the set value is too high, it will introduce a delay in the loop and cause poor responsiveness.				

9.4.7 Speed Feedback Compensation

The speed feedback compensation can be used to reduce vibration and allow a higher speed loop gain to be set. In the end, the speed feedback compensation allows the positioning settling time to be reduced because the position loop gain can also be increased if the speed loop gain can be increased.

Pn110	Online Autotuning Switches			Speed	Position
	Setting Range	Setting Unit	Factory Setting	Setting Validation	
	–	–	0010	After restart	

Pn111	Speed Feedback Compensation			Speed	Position
	Setting Range	Setting Unit	Factory Setting	Setting Validation	
	1 to 500	%	100	Immediately	

Parameter	Function
Pn110 n.□□0□	Speed feedback compensation is used.
n.□□1□	Speed feedback compensation is not used. (Standard speed feedback)

IMPORTANT

When this function is used, it is assumed that the moment of inertia ratio set in Pn103 is correct. Verify that the moment of inertia ratio has been set correctly.

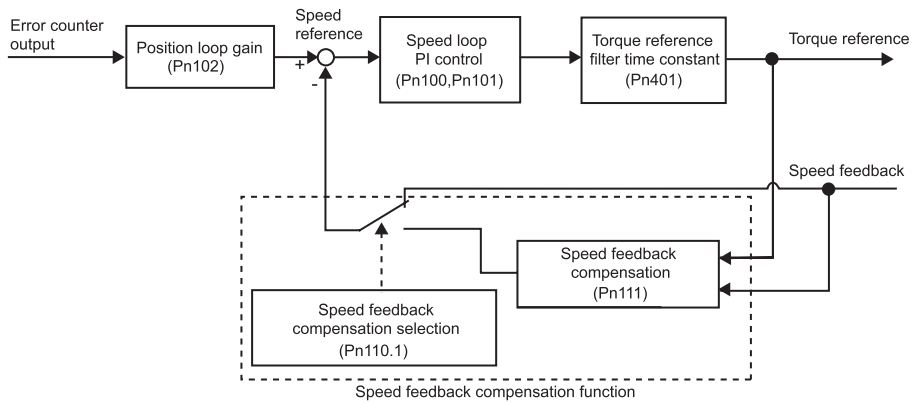

(1) Adjustment Procedure

The following procedure explains how to adjust when the speed loop gain cannot be increased due to vibrations in the mechanical system. When adding a speed feedback compensation, observe the position error and torque reference with the analog monitor while adjusting the servo gain. Refer to *9.5 Analog Monitor* on monitoring the position error and torque reference.

1. Set parameter Pn110 to “0002” so that the following conditions are satisfied.
 - To use the speed feedback compensation
 - Not to use the online autotuning function
2. With PI control, gradually increase the Speed Loop Gain in Pn100 and reduce the Speed Loop Integral Time Constant Pn101, so that the setting the Position Loop Gain in Pn102 to the same value as that of the Speed Loop Gain in Pn100.

Use the result from the following equation as an initial estimate when setting the Speed Loop Integral Time Constant in Pn101.

$$\text{Speed loop integral time constant (Pn101)} = \frac{4000}{2 \pi \times \text{Pn100}}$$

Speed loop gain units: Hz

Check the units when setting the Speed Loop Integral Time Constant in Pn101. The value in Pn101 is set in units of 0.01 ms.

Set the same value for the speed loop gain and position loop gain even though the speed loop gain units (Hz) are different from the position loop gain units (1/s).

3. Repeat step 2 to increase the speed loop gain while monitoring the settling time with the analog monitor’s position error and checking whether vibration occurs in the torque reference. If there is any vibrating noise or noticeable vibration, gradually increase the Torque Reference Filter Time Constant in Pn401.
4. Gradually increase only the position loop gain. When it has been increased about as far as possible, then decrease the Speed Feedback Compensation in Pn111 from 100% to 90%. Then repeat steps 2 and 3.
5. Decrease the speed feedback compensation to a value lower than 90%. Then repeat steps 2 through 4 to shorten the settling time. If the speed feedback compensation is too low, however, the response waveform will oscillate.
6. Find the parameter settings that yield the shortest settling time without causing vibration or instability in the position error or torque reference waveform being observed with the analog monitor.
7. The servo gain adjustment procedure is complete when the positioning time cannot be reduced any more.

IMPORTANT

The speed feedback compensation usually makes it possible to increase the speed loop gain and position loop gain. Once the speed loop gain and position loop gain have been increased, the machine may vibrate significantly and may even be damaged if the compensation value is changed significantly or Pn110.1 is set to “1” (i.e., speed feedback compensation disabled).

9.4.8 Switching Gain Settings

Gain switching by the external signal is possible with the SGDJ SERVOPACK. For example, to use different gains while the servomotor is running or stopped, set two values in the gain settings 1 and 2 and switch the gains by the external signal.

(1) Gain Switching Input Signal

Type	Signal	Connector Pin No.	Setting	Meaning
Input	/G-SEL	Signal allocation required	OFF: H (high) level	Gain settings 1
			ON: L (low) level	Gain settings 2
To use the input signal, the input terminal must be allocated in the parameter Pn50D. Refer to 7.3.2 <i>Input Circuit Signal Allocation</i> .				

(2) Switchable Gain Combinations

Turning ON and OFF the gain switching signal /G-SEL switches the gains as follows.

Gain Switching Signal (/G-SEL)	OFF (H Level)	ON (L Level)
Speed loop gain	Pn100	Pn104
Speed loop integral time constant	Pn101	Pn105
Position loop gain	Pn102	Pn106

(3) Related Parameters

Parameter	Function
Pn50A n.□□□1	Enables the input signal allocation for the sequence.
Set to allocate the gain switching signal (/G-SEL) to an input terminal.	

Pn100	Speed Loop Gain		<input type="checkbox"/> Speed	<input type="checkbox"/> Position
	Setting Range	Setting Unit	Factory Setting	Setting Validation
	1 to 2,000	Hz	40	Immediately
Pn101	Speed Loop Integral Time Constant		<input type="checkbox"/> Speed	<input type="checkbox"/> Position
	Setting Range	Setting Unit	Factory Setting	Setting Validation
	15 to 51,200 (0.15 to 512.00 ms)	0.01 ms	2,000 (20.00 ms)	Immediately
Pn102	Position Loop Gain			<input type="checkbox"/> Position
	Setting Range	Setting Unit	Factory Setting	Setting Validation
	1 to 2,000	1/s	40	Immediately
Pn104	2nd Speed Loop Gain		<input type="checkbox"/> Speed	<input type="checkbox"/> Position
	Setting Range	Setting Unit	Factory Setting	Setting Validation
	1 to 2,000	Hz	40	Immediately
Pn105	2nd Speed Loop Integral Time Constant		<input type="checkbox"/> Speed	<input type="checkbox"/> Position
	Setting Range	Setting Unit	Factory Setting	Setting Validation
	15 to 51,200 (0.15 to 512.00 ms)	0.01 ms	2,000 (20.00 ms)	Immediately
Pn106	2nd Position Loop Gain			<input type="checkbox"/> Position
	Setting Range	Setting Unit	Factory Setting	Setting Validation
	1 to 2,000	1/s	40	Immediately

9.4.9 Torque Reference Filter

As shown in the following diagram, the torque reference filter contains torque reference filter time constant (Pn401) and notch filter frequency (Pn409) arrayed in series. The notch filter can be enabled and disabled using the parameters.

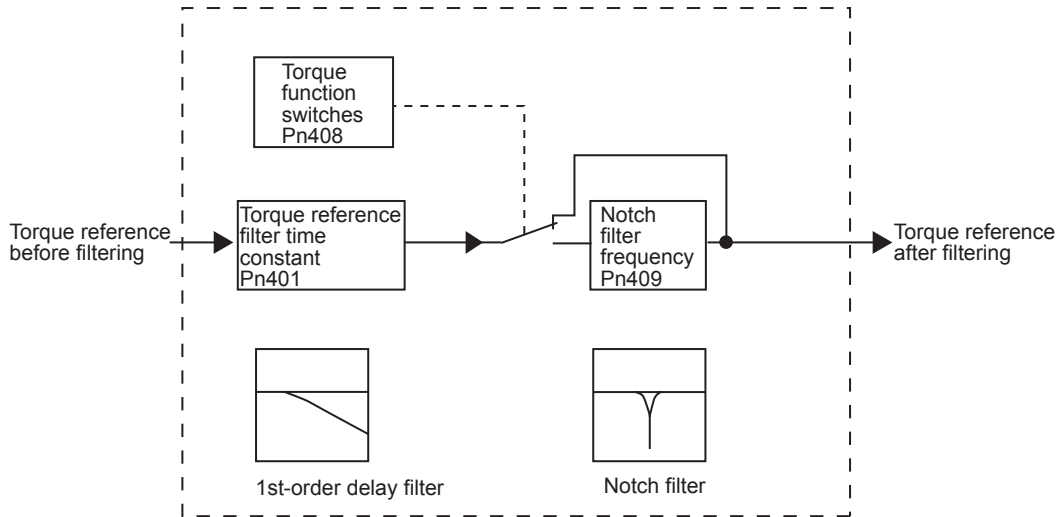

(1) Torque Reference Filter

If you suspect that machine vibration is being caused by the servodrive, try adjusting the filter time constant. This may stop the vibration. The lower the value, the better the speed control response will be, but there is a lower limit that depends on the machine conditions.

Pn401	Torque Reference Filter Time Constant		<input type="checkbox"/> Speed	<input type="checkbox"/> Position	<input type="checkbox"/> Torque
	Setting Range	Setting Unit	Factory Setting	Setting Validation	
	0 to 65,535 (0.00 to 655.35 ms)	0.01 ms	100 (1.00 ms)	Immediately	

(2) Notch Filter

Using the notch filter in accordance with the components of specific vibration frequency such as resonances of ball screw can eliminate the frequency components to stop the vibration.

Parameter	Meaning
Pn408	n.□□□0 Disables the notch filter.
	n.□□□1 Enables the notch filter.
Enables the notch filter to be used. (The setting is validated immediately.)	

Set the machine's vibration frequency in the parameter of a notch filter to be used.

Pn409	Notch Filter Frequency		<input type="checkbox"/> Speed	<input type="checkbox"/> Position	<input type="checkbox"/> Torque
	Setting Range	Setting Unit	Factory Setting	Setting Validation	
	50 to 2,000 Hz	Hz	2,000	Immediately	

IMPORTANT

1. Sufficient precautions must be taken when setting the notch frequency. Do not set the notch filter frequency (Pn409) that is close to the speed loop's response frequency. Set the frequency at least four times higher than the speed loop's response frequency. Setting the notch filter frequency too close to the response frequency may cause vibration and damage the machine. The speed loop response frequency is the value of the Speed Loop Gain (Pn100) when the Moment of Inertia Ratio (Pn103) is set to the correct value.
2. Change the Notch Filter Frequency (Pn409) only when the servomotor is stopped. Vibration may occur if the notch filter frequency is changed when the servomotor is rotating.

9.5 Analog Monitor

Signals for analog voltage references can be monitored.

To monitor analog signals, connect the analog monitor cable (JZSP-CA01 or DE9404559) to the connector CN5.

The analog monitor signals can be selected by setting parameters Pn003.0 and Pn003.1.

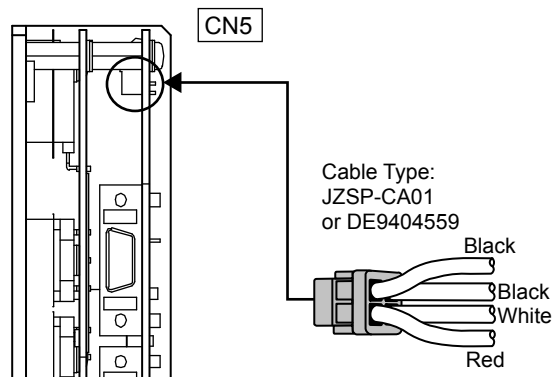

Pin Number	Line Color	Signal Name	Monitoring Item with Factory Setting
1	Red	Analog monitor 2	Motor speed: 1 V/1000 min ⁻¹
2	White	Analog monitor 1	Torque reference: 1 V/100% rated torque
3, 4	Black (2 lines)	GND (0 V)	—

9.5.1 Related Parameters

The following signals can be monitored.

(1) Pn003: Function Selections

	Parameter		Function		
	Monitor 1	Monitor 2	Monitor Signal	Observation Gain	Remarks
Pn003	n.□□□0	n.□□0□	Motor speed	1 V / 1000 min ⁻¹	Factory setting for Monitor 2
	n.□□□1	n.□□1□	Speed reference	1 V / 1000 min ⁻¹	–
	n.□□□2	n.□□2□	Internal torque reference	1 V / 100% rated torque	Factory setting for Monitor 1
	n.□□□3	n.□□3□	Position error *	0.05 V / 1 reference unit	–
	n.□□□4	n.□□4□	Position error *	0.05 V / 100 reference units	–
	n.□□□5	n.□□5□	Position reference speed (converted to motor speed)	1 V / 1000 min ⁻¹	–
	n.□□□6	n.□□6□	Motor speed	1 V / 250 min ⁻¹	–
	n.□□□7	n.□□7□	Motor speed	1 V / 125 min ⁻¹	–
	n.□□□8	n.□□8□	Reserved. Do not set.	–	–
	n.□□□9	n.□□9□			–
	n.□□□A	n.□□A□			–
	n.□□□B	n.□□B□			–
	n.□□□C	n.□□C□			–
	n.□□□D	n.□□D□			–
	n.□□□E	n.□□E□			–
	n.□□□F	n.□□F□			–

* When using speed control or torque control, the position error monitor signal is not specified.



The analog monitor output voltage is ± 5 V (maximum). The output will be limited to ± 5 V even if this value is exceeded in the above calculations.

9.5.2 Manual Zero Adjustment and Gain Adjustment of Analog Monitor Output (Fn00C, Fn00D)

Motor speed, torque reference, and position error can be monitored through the analog monitor output. Refer to *9.5 Analog Monitor*.

Use the manual zero adjustment function to compensate for the output voltage drift or the zero point drift caused by noise entering the monitor system. The gain adjustment function can be changed to match the sensitivity of the measuring system.

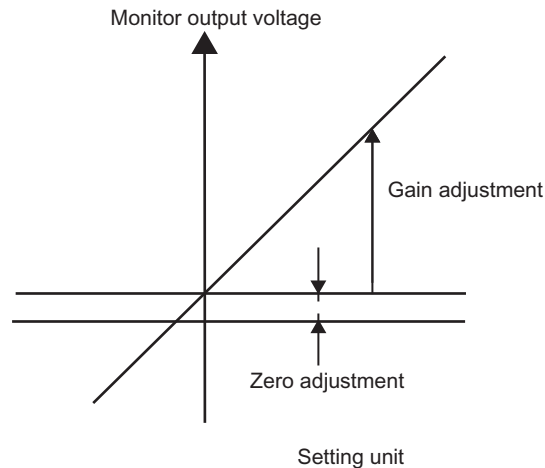

Zero setting range: $\pm 2 \text{ V} \rightarrow 17 \text{ mV/LSB}$
Gain setting range: 50 to 150 % $\rightarrow 0.4 \text{ %LSB}$













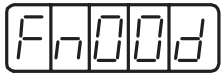

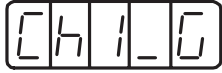
(1) Manual Zero Adjustment of Analog Monitor Output (Fn00C)

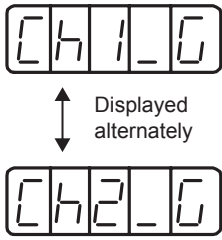
Follow the procedure below to execute the manual zero adjustment of analog monitor output.

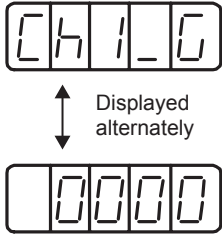
Step	Display after Operation	Key	Description
1		 (DSPL/SET Key)	Press the DSPL/SET Key to select the utility function mode.
2			Press the LEFT/RIGHT Key or the UP/DOWN Key to set the parameter Fn00C.
3		 (DATA/ENTER Key)	Press the DATA/ENTER Key, and “Ch1_o” will be displayed.
4	 ↑↓ Displayed alternately 	 (DSPL/SET Key)	Press the DSPL/SET Key, and the monitor output for the two channels will be displayed alternately.
5	 ↑↓ Displayed alternately 		Press the LEFT or RIGHT Key to display the analog monitor output data. Pressing the LEFT or RIGHT Key again will return to “Ch1_o” or “Ch2_o”.
6			Press the UP or DOWN Key to perform zero adjustment confirming the output waveform of the analog monitor with the measuring device.
7		 (DATA/ENTER Key)	Press the DATA/ENTER Key to return to the utility function mode display Fn00C.

(2) Manual Gain Adjustment of Analog Monitor Output (Fn00D)

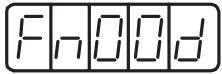
Follow the procedure below to execute the manual gain adjustment of analog monitor output.

Step	Display after Operation	Key	Description
1		 (DSPL/SET Key)	Press the DSPL/SET Key to select the utility function mode.
2			Press the LEFT/RIGHT Key or the UP/DOWN Key to set the parameter Fn00D.
3		 (DATA/ENTER Key)	Press the DATA/ENTER Key, and “Ch1_G” will be displayed.
4	 ↑↓ Displayed alternately	 (DSPL/SET Key)	Press the DSPL/SET Key, and the monitor output for the two channels will be displayed alternately.
5	 ↑↓ Displayed alternately		Press the LEFT or RIGHT Key to display the analog monitor gain constant. Pressing the LEFT or RIGHT Key again will return to “Ch1_G” and “Ch2_G”.
6			Press the UP or DOWN Key to adjust the gain confirming the output waveform of the analog monitor output with the measuring device.
7		 (DATA/ENTER Key)	Press the DATA/ENTER Key to return to the utility function mode display Fn00D.

Inspection, Maintenance, and Troubleshooting

10.1 Troubleshooting	10-2
10.1.1 Alarm Display Table	10-2
10.1.2 Warning Display	10-4
10.1.3 Troubleshooting of Alarm and Warning	10-5
10.1.4 Troubleshooting for Malfunction without Alarm Display	10-13
10.2 Inspection and Maintenance	10-18
10.2.1 Servomotor Inspection	10-18
10.2.2 SERVOPACK Inspection	10-18
10.2.3 SERVOPACK's Parts Replacement Schedule	10-19
10.3 Connection to Host Controller	10-20
10.3.1 Example of Connection to MP920 4-axes Analog Module SVA-01	10-20
10.3.2 Example of Connection to CP-9200SH Servo Controller Module SVA (SERVOPACK in Speed Control Mode)	10-21
10.3.3 Example of Connection to MEMOCON GL120/130 Series Motion Module MC20	10-22
10.3.4 Example of Connection to MEMOCON GL60/70 Series Positioning Module B2813 (SERVOPACK in Position Control Mode)	10-23
10.3.5 Example of Connection to OMRON's Motion Control Unit	10-24
10.3.6 Example of Connection to OMRON's Position Control Unit	10-25
10.3.7 Example of Connection to OMRON's Position Control Unit C500-NC221 (SERVOPACK in Speed Control Mode)	10-26
10.3.8 Example of Connection to OMRON's Position Control Unit C500-NC112 (SERVOPACK in Position Control Mode)	10-27
10.3.9 Example of Connection to MITSUBISHI's AD72 Positioning Unit (SERVOPACK in Speed Control Mode)	10-28
10.3.10 Example of Connection to MITSUBISHI's AD75 Positioning Unit (SERVOPACK in Position Control Mode)	10-29
10.4 List of Parameters	10-30
10.4.1 Utility Functions List	10-30
10.4.2 List of Parameters	10-31
10.4.3 Monitor Modes	10-47

10.1 Troubleshooting

10.1.1 Alarm Display Table

The relation between alarm displays and alarm code outputs is shown in Table 10.1.

If an alarm occurs, the servomotor can be stopped by doing either of the following operations.

- DB STOP: Stops the servomotor immediately using the dynamic brake.
- ZERO-SPEED STOP: Stops the servomotor by setting the speed reference to “0.”

Table 10.1 Alarm Displays and Outputs

Alarm Display	Alarm Name	Meaning	Alarm Reset	Alarm Code Output			Servo Alarm (ALM) Output
				ALO1	ALO2	ALO3	
A.02	Parameter Breakdown	EEPROM data of SERVOPACK is abnormal.	N/A				
A.03	Main Circuit Encoder Error	Detection data for power circuit is abnormal.	Available	H	H	H	H
A.04	Parameter Setting Error	The parameter setting is outside the allowable setting range.	N/A				
A.05	Combination Error	SERVOPACK and servomotor capacities do not match each other.	Available				
A.10	Overcurrent or Heat Sink Overheated	An overcurrent flowed through the IGBT. Heat sink of SERVOPACK was overheated.	N/A	L	H	H	H
A.40	Overvoltage	Main circuit DC voltage is excessively high.	Available	H	H	L	H
A.51	Overspeed	The motor speed is excessively high.	Available	L	H	L	H
A.71	Overload: High Load	The motor was operating for several seconds to several tens of seconds under a torque largely exceeding ratings.	Available				
A.72	Overload: Low Load	The motor was operating continuously under a torque largely exceeding ratings.	Available				
A.73	Dynamic Brake Overload	When the dynamic brake was applied, rotational energy exceeded the capacity of dynamic brake resistor.	Available	L	L	L	H
A.74	Overload of Surge Current Limit Resistor	The main circuit power was frequently turned ON and OFF.	Available				
A.7A	Heat Sink Overheated	The heat sink of SERVOPACK overheated.	Available				

Table 10.1 Alarm Displays and Outputs (cont'd)

Alarm Display	Alarm Name	Meaning	Alarm Reset	Alarm Code Output			Servo Alarm (ALM) Output
				ALO1	ALO2	ALO3	
A.81	Encoder Backup Error	All the power supplies for the absolute encoder have failed and position data was cleared.	N/A	H	H	H	H
A.82	Encoder Checksum Error	The checksum results of encoder memory is abnormal.	N/A				
A.83	Absolute Encoder Battery Error	Backup battery voltage for the absolute encoder has dropped.	Available				
A.84	Encoder Data Error	Data in the encoder is abnormal.	N/A				
A.85	Encoder Overspeed	The encoder was rotating at high speed when the power was turned ON.	N/A				
A.86	Encoder Overheated	The internal temperature of encoder is too high.	N/A				
A.b1	Reference Speed Input Read Error	The A/D converter for reference speed input is faulty.	Available				
A.b2	Reference Torque Input Read Error	The A/D converter for reference torque input is faulty.	Available				
A.bF	System Alarm	A system error occurred in the SERVOPACK.	N/A	L	H	L	H
A.C1	Servo Overrun Detected	The servomotor ran out of control.	Available				
A.C8	Absolute Encoder Clear Error and Multiturn Limit Setting Error	The multiturn for the absolute encoder was not properly cleared or set.	N/A				
A.C9	Encoder Communications Error	Communications between SERVOPACK and encoder is not possible.	N/A				
A.CA	Encoder Parameter Error	Encoder parameters are faulty.	N/A				
A.Cb	Encoder Echoback Error	Contents of communications with encoder is incorrect.	N/A				
A.CC	Multiturn Limit Disagreement	Different multiturn limits have been set in the encoder and SERVOPACK.	N/A				
A.d0	Position Error Pulse Overflow	Position error pulse exceeded parameter (Pn505).	Available	L	L	H	H
CPF00	Digital Operator	Digital operator (JUSP-OP02A-2) fails to communicate with SERVOPACK (e.g., CPU error).	N/A	Not decided			
CPF01	Transmission Error		N/A				
A.--	Not an error	Normal operation status	-	H	H	H	L

10.1.2 Warning Display

The relation between warning displays and warning code outputs is shown in table 10.2.

Table 10.2 Warning Displays and Outputs

Warning Display	Warning Name	Meaning	Warning Code Output		
			ALO1	ALO2	ALO3
A.91	Overload	This warning occurs before the overload alarms (A.71 or A.72) occur. If the warning is ignored and operation continues, an overload alarm may occur.	L	H	H
A.93	Absolute Encoder Battery Voltage Lowered	This warning occurs when the absolute encoder battery voltage is lowered. If the warning is ignored and operation continues, an overload alarm may occur.	L	L	H

Note: Warning code is not output without setting Pn001 = n.1□□□ (Outputs both Alarm Codes and Warning Codes.)

10.1.3 Troubleshooting of Alarm and Warning

When an error occurs in servodrive, an alarm display such as A.□□ and CPF□□ or warning display such as A.9□□ appears on the panel operator. However, the display “A.--” is not an alarm. Refer to the following sections to identify the cause of an alarm and the action to be taken.

Contact your Yaskawa representative if the problem cannot be solved by the described corrective action.

(1) Alarm Display and Troubleshooting

Table 10.3 Alarm Display and Troubleshooting

Alarm Display	Alarm Name	Situation at Alarm Occurrence	Cause	Corrective Actions
A.02	Parameter Breakdown (The EEPROM data storing the parameter is incorrect.)	Occurred when the control power supply was turned ON.	The control power supply voltage is low.	Correct the power supply, and set Fn005 to initialize the parameter.
			The power supply was turned OFF while changing the parameter setting. The power supply was turned OFF while an alarm was being written.	Set Fn005 to initialize the parameter and input the parameter again.
			The number of times that parameters were written exceeded the limit. For example, the parameter was changed every scan through the host controller.	Replace the SERVOPACK. (Recheck the parameter writing method.)
			The SERVOPACK EEPROM and the related circuit are faulty.	Replace the SERVOPACK.
A.03	Main Circuit Encoder Error	Occurred when the control power supply was turned ON or during operation	The control power supply voltage is low.	Correct the power supply. Replace the SERVOPACK.
A.04	Parameter Setting Error (The parameter setting was out of the allowable setting range.)	Occurred when the control power supply was turned ON.	The incorrect parameter was being loaded. (The incorrect value was rejected as an error at the digital operator.)	Set Fn005 to initialize the parameter.
			The SERVOPACK EEPROM and the related circuit are faulty.	Replace the SERVOPACK.
A.05	Combination Error (The SERVOPACK and servomotor capacities do not correspond.)	Occurred when the control power supply was turned ON.	The SERVOPACK and servomotor capacities do not correspond to each other. Servomotor capacity / SERVOPACK capacity $\leq 1/4$ or servomotor capacity / SERVOPACK capacity ≥ 4	Select the proper combination of SERVOPACK and servomotor capacities.
			The parameter that is written in the encoder is incorrect.	Replace the servomotor (encoder).
			A SERVOPACK board fault occurred.	Replace the SERVOPACK.

Table 10.3 Alarm Display and Troubleshooting (cont'd)

Alarm Display	Alarm Name	Situation at Alarm Occurrence	Cause	Corrective Actions
A.10	Overcurrent (An overcurrent flowed through the MOS-FET) or Heat Sink Overheated	Occurred when the control power supply was turned ON.	The overload alarm has been reset by turning OFF the power too many times.	Change the method to reset the alarm.
			The connection is faulty between the SERVOPACK board and the thermostat switch.	Replace the SERVOPACK.
			The SERVOPACK board fault occurred.	
		Occurred when the main circuit power supply was turned ON or when an overcurrent occurred while the servomotor was running.	The connection between grounding and U, V, or W is incorrect.	Check and then correct the wiring.
			The grounding line has contact with other terminals.	
			A short circuit occurred between the grounding and U, V, or W of the servomotor cable.	Repair or replace the servomotor main circuit cable.
			A short circuit occurred between phases U, V, and W of the servomotor.	
			The wiring of the regenerative resistor is incorrect.	Check and then correct the wiring.
			A short circuit occurred between the grounding and U, V, or W of the SERVOPACK.	Replace the SERVOPACK.
			A SERVOPACK fault occurred (current feedback circuit, power transistor or board fault).	
			A short circuit occurred between the grounding and U, V, W of the servomotor.	Replace the servomotor.
			A short circuit occurred between phases U, V, and W of the servomotor.	
			The dynamic brake was activated too frequently, so a DB overload alarm occurred.	Replace the SERVOPACK, and reduce the DB operation frequency.
			The overload alarm has been reset by turning OFF the power too many times.	Change the method to reset the alarm.
			The excessive change was given to the position/speed reference.	Recheck the reference value.
			The overload or regenerative power exceeds the regenerative resistor's capacity.	Reconsider the load and operation conditions.
			The direction or the distance of the SERVOPACK to other devices is incorrect. Heat radiation of the panel or heat around the panel occurred.	The ambient temperature for the SERVOPACK must be 40 °C or less.
A SERVOPACK fan fault occurred.	Replace the SERVOPACK.			
A SERVOPACK fault occurred.				
A.40	Overvoltage*1 (Detected when the DC voltage of the SERVOPACK's main circuit is 33 VDC for the 24 VDC model and 60 VDC or more for the 480 VDC model.) (Detected when the power to the main circuit is turned ON.)	Occurred when the control power supply was turned ON.	A SERVOPACK board fault occurred.	Replace the SERVOPACK.
			Occurred when the main circuit power supply was turned ON.	The DC power voltage is too high.
		Occurred during normal operation.	A SERVOPACK fault occurred.	Replace the SERVOPACK.
			Check the DC power voltage (check if there is no excessive voltage change.)	The DC power voltage must be within the specified range.
			The motor speed is high and load moment of inertia is excessive, resulting in insufficient regenerative capacity.	Check the load moment of inertia and minus load specifications. Reconsider the load and operation conditions.
Occurred at servomotor deceleration.	A SERVOPACK fault occurred.	Replace the SERVOPACK.		
	The motor speed is high, and the load moment of inertia is excessive.	Reconsider the load and operation conditions.		

Table 10.3 Alarm Display and Troubleshooting (cont'd)

Alarm Display	Alarm Name	Situation at Alarm Occurrence	Cause	Corrective Actions		
A.51	Overspeed (Detected when the feedback speed is the maximum motor speed)	Occurred when the control power supply was turned ON.	A SERVOPACK board fault occurred.	Replace the SERVOPACK.		
			Occurred when servo was ON.	The order of phases U, V, and W in the servomotor wiring is incorrect.	Correct the servomotor wiring.	
				The encoder wiring is incorrect.	Correct the encoder wiring.	
		Malfunction occurred due to noise interference in the encoder wiring.		Take measures against noise for the encoder wiring.		
		A SERVOPACK fault occurred.		Replace the SERVOPACK.		
		Occurred when the servomotor started running or in a high-speed rotation.	The order of phases U, V, and W in the servomotor wiring is incorrect.	Correct the servomotor wiring.		
			The encoder wiring is incorrect.	Correct the encoder wiring.		
			Malfunction occurred due to noise interference in the encoder wiring.	Take measures against noise for the encoder wiring.		
			The position or speed reference input is too large.	Reduce the reference value.		
			The setting of the reference input gain is incorrect.	Correct the reference input gain setting.		
			A SERVOPACK board fault occurred.	Replace the SERVOPACK.		
			A SERVOPACK board fault occurred.	Replace the SERVOPACK.		
		A.71 A.72	A.71: High Load A.72: Low Load	Occurred when the control power supply was turned ON.	A SERVOPACK board fault occurred.	Replace the SERVOPACK.
Occurred when the servo was ON.	The servomotor wiring is incorrect or the connection is faulty.				Correct the servomotor wiring.	
	The encoder wiring is incorrect or the connection is faulty.				Correct the encoder wiring.	
	A SERVOPACK fault occurred.			Replace the SERVOPACK.		
Occurred when the servomotor did not run by the reference input.	The servomotor wiring is incorrect or the connection is faulty.			Correct the servomotor wiring.		
	The encoder wiring is incorrect or the connection is faulty.			Correct the encoder wiring.		
	The starting torque exceeds the maximum torque.			Reconsider the load and operation conditions, or reconsider the servomotor capacity.		
	A SERVOPACK fault occurred.			Replace the SERVOPACK.		
Occurred during normal operation.	The actual torque exceeds the rated torque or the starting torque largely exceeds the rated torque.			Reconsider the load and operation conditions, or reconsider the servomotor capacity.		
	Temperature in the SERVOPACK panel is high.			Reduce the in-panel temperature to 40 °C or less.		
	A SERVOPACK fault occurred.			Replace the SERVOPACK.		
A.73	Dynamic Brake Overload			Occurred when the control power supply was turned ON.	A SERVOPACK board fault occurred.	Replace the SERVOPACK.
					A SERVOPACK board fault occurred.	Replace the SERVOPACK.
		Occurred when the servomotor was running and in a status other than servo OFF.	The rotating energy at a DB stop exceeds the DB resistance capacity.	①Reduce the motor speed, ②Reduce the load moment of inertia, or ③Reduce the number of times of the DB stop operation.		
			A SERVOPACK fault occurred.	Replace the SERVOPACK.		

Table 10.3 Alarm Display and Troubleshooting (cont'd)

Alarm Display	Alarm Name	Situation at Alarm Occurrence	Cause	Corrective Actions
A.74	Overload of Surge Current Limit Resistor (Detected when the number of times that the main circuit's power is turned ON or OFF more than 10 times/2 seconds.)	Occurred when the control power supply was turned ON.	A SERVOPACK board fault occurred.	Replace the SERVOPACK.
		Occurred during operations other than the turning ON/OFF of the main circuit.	A SERVOPACK board fault occurred.	Replace the SERVOPACK.
		Occurred at the main circuit power supply ON/OFF operation.	The surge current limit resistor operation frequency at the main circuit power supply ON/OFF operation exceeds the allowable range. A SERVOPACK fault occurred.	Reduce the number of times that main circuit's power supply can be turned ON/OFF to 5 times/min. or less. Replace the SERVOPACK.
A.7A	Heat Sink Overheated (Detected when the heat sink temperature exceeds $100 \times ^\circ\text{C}$.)	Occurred when the control power supply was turned ON.	A SERVOPACK fault occurred. The overload alarm has been reset by turning OFF the power too many times.	Replace the SERVOPACK. Change the method to reset the alarm.
		Occurred when the main circuit power supply was turned ON or while the servomotor was running.	The load exceeds the rated load.	Reconsider the load and operation conditions, or reconsider the servomotor capacity.
			The SERVOPACK ambient temperature exceeds 40°C .	The ambient temperature must be 40°C or less.
			A SERVOPACK fault occurred.	Replace the SERVOPACK.
A.81	Encoder Backup Error (Detected on the encoder side.) (Only when an absolute encoder is connected.)	Occurred when the control power supply was turned ON. (Setting: Pn002.2=1)	A SERVOPACK board fault occurred when an absolute encoder is used with the setting for incremental encoder.	Replace the SERVOPACK.
		Occurred when the control power supply was turned ON using an absolute encoder. (Setting: Pn002.2=0)	Alarm occurred when the power to the absolute encoder was initially turned ON.	Set up the encoder.
			The encoder cable had been disconnected once.	First confirm the connection and set up the encoder.
			The power from both the PG power supply (+5 V) and the battery power supply from the SERVOPACK is not being supplied.	Replace the battery or take similar measures to supply power to the encoder, and set up the encoder.
			An absolute encoder fault occurred.	If the alarm cannot be reset by setting up the encoder again, replace the encoder.
A SERVOPACK fault occurred.	Replace the SERVOPACK.			
A.82	Encoder Checksum Error (Detected on the encoder side.)	Occurred when the control power supply was turned ON or during an operation.	A fault occurred in the encoder and was detected by encoder self-diagnosis. A SERVOPACK fault occurred.	Set up the encoder. If this alarm occurs frequently, replace the servomotor. Replace the SERVOPACK.
		Occurred when the SEN signal turned ON.	A fault occurred in the encoder and was detected by encoder self-diagnosis.	Set up the encoder. If this alarm occurs frequently, replace the servomotor.
		A.83	Absolute Encoder Battery Error (Detected when the battery voltage is lower than the specified value 2 to 4 s after the control power supply is turned ON.) (Only when an absolute encoder is connected.)	When the control power supply was turned ON. (Setting: Pn002.2=1)
When the control power supply was turned ON using an absolute encoder. (Setting: Pn002.2=0)	The battery connection is incorrect.			Reconnect the battery.
	The battery voltage is lower than the specified value 2.7 V. A SERVOPACK board fault occurred.			Replace the battery, and then turn ON the power to the encoder. Replace the SERVOPACK.

Table 10.3 Alarm Display and Troubleshooting (cont'd)

Alarm Display	Alarm Name	Situation at Alarm Occurrence	Cause	Corrective Actions
A.84	Encoder Data Error (Detected on the encoder side.)	Occurred when the control power supply was turned ON.	A malfunction occurred in the encoder.	Turn the encoder power supply OFF and then ON again. If this alarm occurs frequently, replace the servomotor.
			A SERVOPACK board fault occurred.	Replace the SERVOPACK.
		Occurred during normal operation.	A malfunction occurred in the encoder due to external noise.	Correct the wiring around the encoder by separating the encoder cable from the power line, or by checking the grounding and other wiring.)
			An encoder fault occurred.	If this alarm occurs frequently, replace the servomotor.
		A SERVOPACK board fault occurred.	Replace the SERVOPACK.	
A.85	Encoder Over-speed (Detected when the encoder power supply was turned ON.) (Detected on the encoder side.)	Occurred when the control power supply was turned ON.	When the encoder power supply turns ON and the SEN signal is ON when using an absolute encoder, the servomotor runs at 200 min ⁻¹ or more.	Turn ON the encoder power supply when the servomotor runs at a speed less than 200 min ⁻¹ .
			An encoder fault occurred.	Replace the servomotor.
			A SERVOPACK board fault occurred.	Replace the SERVOPACK.
		Occurred during normal operation.	An encoder fault occurred.	Replace the servomotor.
A SERVOPACK board fault occurred.	Replace the SERVOPACK.			
A.86	Encoder Overheated (Only when an absolute encoder is connected.) (Detected on the encoder side.)	Occurred when the control power supply was turned ON.	An encoder fault occurred.	Replace the servomotor.
			A SERVOPACK board fault occurred.	Replace the SERVOPACK.
		Occurred during normal operation.	The ambient temperature around the servomotor is too high.	The ambient temperature must be 40°C or less.
			The servomotor load is greater than the rated load.	The servomotor load must be within the specified range.
		An encoder fault occurred.	Replace the servomotor.	
		A SERVOPACK board fault occurred.	Replace the SERVOPACK.	
A.b1	Reference Speed Input Read Error (Detected when the Servo is ON.)	Occurred when the control power supply was turned ON.	A SERVOPACK board fault occurred.	Replace the SERVOPACK.
		Occurred during normal operation.	A malfunction occurred in reading section of the speed reference input.	Clear and reset the alarm and restart the operation.
			A SERVOPACK board fault occurred.	Replace the SERVOPACK.
A.b2	Reference Torque Input Read Error (Detected when the servo is ON.)	Occurred when the control power supply was turned ON.	A SERVOPACK board fault occurred.	Replace the SERVOPACK.
		Occurred during normal operation.	A malfunction occurred in the reading section of the torque reference input.	Clear and reset the alarm and restart the operation.
			A SERVOPACK board fault occurred.	Replace the SERVOPACK.
A.bF	System Alarm (Program error) • Software operation time exceeded • Stack overflow • Micro program error	Occurred when the control power supply was turned ON.	A SERVOPACK board fault occurred.	Replace the SERVOPACK.
		Occurred during normal operation.	A program is incorrect.	Replace the SERVOPACK. (Contact your Yaskawa representative.)
			A SERVOPACK board fault occurred.	Replace the SERVOPACK.
A.C1	Servo Overrun Detected (Detected when the servo is ON.)	Occurred when the control power supply was turned ON.	A SERVOPACK board fault occurred.	Replace the SERVOPACK.
		Occurred when the servo was ON or a reference was input.	The order of phase U, V, and W in the servomotor wiring is incorrect.	Correct the servomotor wiring.
			An encoder fault occurred.	Replace the servomotor.
			A SERVOPACK fault occurred.	Replace the SERVOPACK.

Table 10.3 Alarm Display and Troubleshooting (cont'd)

Alarm Display	Alarm Name	Situation at Alarm Occurrence	Cause	Corrective Actions
A.C8	Absolute Encoder Clear Error and Multi-turn Limit Setting Error	Occurred when the control power supply was turned ON.	An encoder fault occurred.	Replace the servomotor.
			A SERVOPACK board fault occurred.	Replace the SERVOPACK.
		Occurred when an encoder alarm was cleared and reset.	An encoder fault occurred.	Replace the servomotor.
			A SERVOPACK board fault occurred.	Replace the SERVOPACK.
A.C9	Encoder Communications Error	Occurred when the control power supply was turned ON or during operation.	The encoder wiring and the contact are incorrect.	Correct the encoder wiring.
			Noise interference occurred due to incorrect encoder cable specifications.	Use tinned annealed copper twisted-pair or twisted-pair shielded wire with a core of at least 0.12 mm ² (0.0002 in ²).
			Noise interference occurred because the wiring distance for the encoder cable is too long.	The wiring distance must be 20m (65.6 ft) max.
			The noise interference occurred on the signal line because the encoder cable is bent and the sheath is damaged.	Correct the encoder cable layout.
			The encoder cable is bundled with a high-current line or near a high-current line.	Correct the encoder cable layout so that no surge is applied.
			The FG electrical potential varies because of the influence from such machines on the servomotor side as welders.	Ground the machine separately from PG side FG.
			Noise interference occurred on the signal line from the encoder.	Take a measure against noise for the encoder wiring.
			Excessive vibration and shocks were applied to the encoder.	Reduce the machine vibration or mount the servomotor securely.
			An encoder fault occurred.	Replace the servomotor.
			A SERVOPACK board fault occurred.	Replace the SERVOPACK.
A.CA	Encoder Parameter Error	Occurred when the control power supply was turned ON.	An encoder fault occurred.	Replace the servomotor.
			A SERVOPACK board fault occurred.	Replace the SERVOPACK.
A.Cb	Encoder Echoback Error	Occurred when the control power supply was turned ON or during operation.	The encoder wiring and contact are incorrect.	Correct the encoder wiring.
			Noise interference occurred due to incorrect encoder cable specifications.	Use tinned annealed copper twisted-pair or twisted-pair shielded wire with a core of at least 0.12 mm ² (0.0002 in ²).
			Noise interference occurred because the wiring distance for the encoder cable is too long.	The wiring distance must be 20m (65.6 ft) max.
			Noise interference occurred on the signal line, because the encoder cable is bent and the sheath is damaged.	Correct the encoder cable layout.
			The encoder cable is bundled with a high-current line or near a high-current line.	Correct the encoder cable layout so that no surge is applied.
			The FG electrical potential varies because of the influence from such machines on the servomotor side as welders.	Ground the machine separately from PG side FG.
			Noise interference occurred on the signal line from the encoder.	Take measures against noise for the encoder wiring.
			Excessive vibration and shocks to the encoder was applied.	Reduce the machine vibration or mount the servomotor securely.
			An encoder fault occurred.	Replace the servomotor.
			A SERVOPACK board fault occurred.	Replace the SERVOPACK.
A.CC	Multiturn Limit Disagreement	Occurred when the control power supply was turned ON.	The parameter settings for the SERVOPACK are incorrect.	Correct the setting of Pn205 (0 to 65535).
			The multiturn limit value for the encoder is not set or was changed.	Execute Fn013 at the occurrence of alarm.
		Occurred during normal operation.	A SERVOPACK board fault occurred.	Replace the SERVOPACK.

Table 10.3 Alarm Display and Troubleshooting (cont'd)

Alarm Display	Alarm Name	Situation at Alarm Occurrence	Cause	Corrective Actions
A.d0	Position Error Pulse Overflow (In servo ON status, the position error pulses exceed the overflow level set in the parameter Pn505.)	Occurred when the control power supply was turned ON.	The overflow level (Pn505) is incorrect.	Make the value set in the Pn505 to other than 0.
			A SERVOPACK board fault occurred.	Replace the SERVOPACK.
		Occurred at the servomotor high-speed rotation.	The contact in the servomotor U, V, and W wirings is faulty.	Correct the servomotor wiring. Correct the encoder wiring.
			A SERVOPACK board fault occurred.	Replace the SERVOPACK.
		The servomotor did not run with position reference input.	Wirings of the servomotor U, V, and W are incorrect.	Correct the servomotor wiring.
			A SERVOPACK board fault occurred.	Replace the SERVOPACK.
		Normal movement, but occurred with a long distance reference input.	The SERVOPACK gain adjustment is improper.	Increase the speed loop gain (Pn100) and position loop gain (Pn102).
			The V-REF input voltage and the Pn300 setting are incorrect.	Lower the reference speed to the speed limit value.
			The position reference pulse frequency is too high.	Adjust slowly the position reference pulse frequency. Apply the smoothing function.
				Correct the electronic gear ratio.
Setting of the position error pulse overflow alarm level (Pn505) is incorrect.	Set the parameter Pn505 to proper value.			
The servomotor specifications do not meet the load conditions such as torque and moment of inertia.	Reconsider and correct the load and servomotor capacity.			
CPF00	Digital Operator Transmission Error 1 *2	Occurred when the power supply was turned ON with digital operator connected or when connecting digital operator with the power supply was turned ON.	The contact between the digital operator and the SERVOPACK is faulty.	Insert securely the connector, or replace the cable.
			The external noise interference occurred to the digital operator or cable. (The digital operator cable is near noise source.)	Do not lay the cable near noise source. Install digital operator far from noise source.
				A digital operator fault occurred.
CPF01	Digital Operator Transmission Error 2 *3		A SERVOPACK fault occurred.	Replace the SERVOPACK.

* 1. This alarm occurs when the communications is still disabled five seconds after digital operator power supply is ON, or when digital operator communications disabled status stays while an application module is connected.

* 2. This alarm occurs when digital operator received data error occurs consecutively five times, or when the state that digital operator receives no data from SERVOPACK for one second or more occurs consecutively three times.

(2) Warning Display and Troubleshooting

Table 10.4 Warning Display and Troubleshooting

Warning Display	Warning Name	Situation at Warning Occurrence	Cause	Corrective Actions
A.91	Overload: Warning for the alarms A71 and A72 In either of the following cases: 1. 20% of the overload detection level of A71 2. 20% of the overload detection level of A72.	Occurs when the servo was ON.	Wiring is incorrect and the contact in servomotor wiring is faulty.	Correct the servomotor wiring.
			Wiring is incorrect and the contact in encoder wiring is faulty.	Correct the encoder wiring.
			A SERVOPACK fault occurred.	Replace the SERVOPACK.
		The servomotor did not run with a reference input.	Servomotor wiring is incorrect and the contact is faulty.	Correct the servomotor wiring.
			Encoder wiring is incorrect and the contact is faulty.	Correct the encoder wiring.
			The starting torque exceeds the maximum torque.	Reconsider the load and operation conditions. Or, check the servomotor capacity.
			A SERVOPACK fault occurred.	Replace the SERVOPACK.
		Occurred during normal operation.	The effective torque exceeds the rated torque.	Reconsider the load and operation conditions. Or, check the servomotor capacity.
			Temperature in the SERVOPACK panel is high.	Reduce the in-panel temperature to 55°C or less.
			A SERVOPACK fault occurred.	Replace the SERVOPACK.
A.93	Absolute Encoder Battery Warning (The battery voltage stays below the specified value 4 seconds after the control power supply was turned ON.) (Only when an absolute encoder is connected.)	Occurred when the control power supply was turned ON (Setting: Pn002.2=1).	A SERVOPACK board fault occurred. (The absolute encoder is used in the incremental encoder setting.)	Replace the SERVOPACK.
			The battery connection is incorrect or faulty.	Connect correctly the battery.
		Occurred 4 seconds or more after the control power supply was turned ON (Setting: Pn002.2=0). When an absolute encoder was used.	The battery voltage is lower than the specified value 2.7 V.	Replace the battery, and turn OFF the encoder power supply and ON again.
			A SERVOPACK board fault occurred.	Replace the SERVOPACK.

10.1.4 Troubleshooting for Malfunction without Alarm Display

The troubleshooting for the malfunctions that causes no alarm display is listed below.
Contact your Yaskawa representative if the problem cannot be solved by the described corrective actions.

Table 10.5 Troubleshooting for Malfunction without Alarm Display

Symptom	Cause	Inspection	Corrective Actions
		■: Turn OFF the servo system before executing operations.	
Servomotor Does Not Start	The control power supply is not ON.	Check voltage between control power supply terminals.	Correct the control power circuit.
	The main circuit power supply is not ON.	Check the voltage between power supply terminals.	Correct the power circuit.
	Wrong wiring or disconnection of I/O signal connector CN1	Check if the connector CN1 is properly inserted and connected.	Correct the connector CN1 connection.
	Servomotor or encoder wiring disconnected.	Check the wiring.	Correct the wiring.
	Overloaded	Run under no load.	Reduce load or replace with larger capacity servomotor.
	Speed/position references not input	Check reference input pins.	Input speed/position references correctly.
	Setting for Pn50A to Pn50D “Input Signal Selection” is incorrect.	Check settings of parameters Pn50A to Pn50D.	Correct the settings for Pn50A to Pn50D “Input Signal Selection.”
	Encoder type differs from parameter setting.	Check incremental or absolute encoder.	Set parameter Pn002.2 to the encoder type being used.
	/S-ON input signal stays OFF.	Check settings of parameters Pn50A.0 and Pn50A.1.	Correct the parameter setting and turn ON /S-ON input signal.
	/P-CON input function setting is incorrect.	Check parameter Pn001.1.	Set parameters to match the application.
	SEN input is turned OFF.	Check the SEN signal input (when absolute encoder is used).	Turn SEN input signal ON.
	Reference pulse mode selection is incorrect.	Check the parameter setting for the reference pulse mode.	Correct setting of parameter Pn200.0.
	Speed control: Speed reference input is incorrect.	Check V-REF and SG to confirm if the control method and the input are agreed.	Correct the control mode selection parameter, or the input.
	Torque control: Torque reference input is incorrect.	Check V-REF and SG to confirm if the control method and the input are agreed.	Correct the control mode selection parameter, or the input.
	Position control: Reference pulse input is incorrect.	Check Pn200.0 reference pulse form or sign + pulse signal.	Correct the control mode selection parameter, or the input.
	The error clear counter (CLR) input is turned ON.	Check CLR or /CLR input pins (CN1-14 and -15).	Turn CLR or /CLR input signal OFF.
The forward run prohibited (P-OT) or reverse run prohibited (N-OT) input signal is turned OFF.	Check P-OT or N-OT input signal.	Turn P-OT or N-OT input signal ON.	
A SERVOPACK fault occurred.	A SERVOPACK board fault occurred.	Replace the SERVOPACK.	
Servomotor Moves Instantaneously, and then Stops	Servomotor wiring is incorrect.	Check the servomotor wiring.	Correct the servomotor wiring.
	Encoder wiring is incorrect.	Check the encoder wiring.	Correct the encoder wiring.
Servomotor Suddenly Stops during Operation and will Not Restart	An alarm occurred while alarm reset signal (ALM-RST) was turned ON.	Check the alarm reset signal.	Remove the cause of alarm. Turn alarm reset signal (ALM-RST) from ON to OFF.
Servomotor Speed Unstable	Wiring connection to servomotor is defective.	Check connection of power lead (phases U, V, and W) and encoder connectors.	Tighten any loose terminals or connectors.

Table 10.5 Troubleshooting for Malfunction without Alarm Display (cont'd)

Symptom	Cause	Inspection	Corrective Actions
		■: Turn OFF the servo system before executing operations.	
Servomotor Rotates Without Reference Input	Speed control: Speed reference input is incorrect.	Check V-REF and SG to confirm if the control method and the input are agreed.	Correct the control mode selection parameter, or the input correctly.
	Torque control: Torque reference input is incorrect.	Check V-REF and SG to confirm if the control method and the input are agreed.	Correct the control mode selection parameter, or the input correctly.
	Speed reference offset is error.	The SERVOPACK offset is adjusted incorrectly.	Adjust the SERVOPACK offset correctly.
	Position control: Reference pulse input is incorrect.	Check Pn200.0 reference pulse form or sign + pulse signal.	Correct the control mode selection parameter, or the input correctly.
	A SERVOPACK fault occurred.	A SERVOPACK board fault occurred.	Replace the SERVOPACK.
DB (dynamic brake) Does Not Operate	Improper parameter setting	Check the setting of parameter Pn001.0.	Correct the parameter setting.
	DB resistor disconnected	Check if excessive moment of inertia, motor overspeed, or DB frequently activated occurred.	Replace the SERVOPACK, and reconsider the load.
	DB drive circuit fault	DB circuit parts are faulty.	Replace the SERVOPACK.
Abnormal Noise from Servomotor	Mounting not secured	Check if there are any loosen mounting screws.	Tighten the mounting screws.
		Check if there are misalignment of couplings.	Align the couplings.
		Check if there are unbalanced couplings.	Balance the couplings.
	Defective bearings	Check for noise and vibration around the bearings.	If any problems, contact your Yaskawa representative.
	Vibration source on the driven machine	Any foreign matter, damages, or deformation on the machine movable section.	Contact the machine manufacturer.
	Noise interference due to incorrect input signal wire specifications	The specifications of input signal wires must be: Twisted-pair or twisted-pair shielded wire with core 0.12 mm ² (0.0002 in ²) min. and tinned annealed copper twisted wire.	Use the specified input signal wires.
	Noise interference due to long distance of input signal line	The wiring distance must be 3 m (9.84 ft) max. and the impedance a few hundreds ohm max.	Shorten the wiring distance for input signal line to the specified value.
	Noise interference due to incorrect encoder cable specifications	The specifications of encoder cable must be: Twisted-pair or twisted-pair shielded wire with core 0.12 mm ² (0.0002 in ²) min. and tinned annealed copper twisted wire.	Use the specified encoder cable.
	Noise interference due to long encoder cable wiring distance	The wiring distance must be 20 m(65.6 ft) max.	Shorten the encoder cable wiring distance to the specified value.
	Noise due to damaged encoder cable	Check if the encoder cable is not damaged or bent.	Modify the encoder cable layout.
	Excessive noise to the encoder cable	Check if the encoder cable is bundled with high-current line or near the high-current line.	Install a surge suppressor to the encoder cable.
	FG electrical potential varies by influence of such machines on the servomotor side as welders.	Check if the machine is correctly grounded.	Ground the machine separately from PG side FG.
	SERVOPACK pulse counting error due to noise	Check if there is noise interference on the signal line from encoder.	Take measure against noise for the encoder wiring.
Excessive vibration and shock to the encoder	Vibration from the machine occurred or servomotor installation is incorrect. (Mounting surface accuracy, fixing, alignment, etc.)	Reduce vibration from the machine, or secure the servomotor installation.	
Encoder fault	An encoder fault occurred.	Replace the servomotor.	

Table 10.5 Troubleshooting for Malfunction without Alarm Display (cont'd)

Symptom	Cause	Inspection	Corrective Actions
		■: Turn OFF the servo system before executing operations.	
Servomotor Vibrates at about 200 to 400 Hz	Speed loop gain value (Pn100) too high.	Factory setting: $K_v=40.0$ Hz Refer to 9.3.2 <i>Servo Gain Manual Tuning</i> .	Reduce speed loop gain (Pn100) preset value.
	Position loop gain value (Pn102) too high	Factory setting: $K_p=40.0/s$ Refer to 9.3.2 <i>Servo Gain Manual Tuning</i> .	Reduce position loop gain (Pn102) preset value.
	Incorrect speed loop integral time constant (Pn101) setting	Factory setting: $T_i=20.00$ ms Refer to 9.3.2 <i>Servo Gain Manual Tuning</i> .	Correct the speed loop integral time constant (Pn101) setting.
	When the autotuning is used: Incorrect machine rigidity setting	Check the machine rigidity setting (Fn001).	Select a proper machine rigidity setting (Fn001).
	When the autotuning is not used: Incorrect rotational moment of inertia ratio data	Check the rotational moment of inertia ratio data (Pn103).	Correct the rotational moment of inertia ratio data (Pn103).
High Rotation Speed Overshoot on Starting and Stopping.	Speed loop gain value (Pn100) too high	Factory setting: $K_v=40.0$ Hz Refer to the gain adjustment in User's Manual.	Reduce the speed loop gain (Pn100) preset value.
	Position loop gain value (Pn102) too high	Factory setting: $K_p=40.0/s$ Refer to the gain adjustment in User's Manual.	Reduce the position loop gain (Pn102) preset value.
	Incorrect speed loop integral time constant (Pn101) setting	Factory setting: $T_i=20.00$ ms Refer to the gain adjustment in User's Manual.	Correct the speed loop integral time constant (Pn101) setting.
	When the autotuning is used: Incorrect machine rigidity setting	Check the machine rigidity setting (Fn001).	Select a proper machine rigidity setting (Fn001).
	When the autotuning is not used: Incorrect rotational moment of inertia ratio data	Check the rotational moment of inertia ratio data (Pn103).	Correct the rotational moment of inertia ratio data (Pn103). Use the mode switch setting function.
Absolute Encoder Position Difference Error (The position saved in host controller when the power turned OFF is different from the position when the power turned ON.)	Noise interference due to improper encoder cable specifications	The specifications of encoder cable must be: Twisted-pair or twisted-pair shielded wire with core 0.12 mm^2 (0.0002 in^2) min. and tinned annealed copper twisted wire.	Use encoder cable with the specified specifications.
	Noise interference because the encoder cable distance is too long.	The wiring distance must be 20 m (65.6 ft) max.	The encoder cable distance must be within the specified range.
	Noise interference due to damaged encoder cable	Noise interference occurred to the signal line because the encoder cable is bent or its sheath damaged.	Correct the encoder cable layout.
	Excessive noise to the encoder cable	Check if the encoder cable is bundled with a high-current line or near high-current line.	Change the encoder cable layout so that no surge is applied.
	FG electrical potential varies by influence of such machines on the servomotor side as welder.	Check if the machine is correctly grounded.	Ground the machine separately from PG side FG.
	SERVOPACK pulse counting error due to noise interference	Check if the signal line from the encoder receives influence from noise interference.	Take measures against noise for encoder wiring.
	Excessive vibration and shock to the encoder	Vibration from machine occurred or servomotor mounting such as mounting surface precision, fixing, and alignment is incorrect.	Reduce vibration from machine or mount securely the servomotor.
	Encoder fault	An encoder fault occurred. (no change in pulse count)	Replace the servomotor.
	SERVOPACK fault	Check the multiturn data from SERVOPACK.	Replace the SERVOPACK.
	Host controller multiturn data reading error	Check the error detection at the host controller.	Correct the error detection section of host controller.
Check if the host controller executes data parity check.		Execute the multiturn data parity check.	
Check noise on the signal line between SERVOPACK and the host controller.		Noise influence at no parity check (as the above.)	

Table 10.5 Troubleshooting for Malfunction without Alarm Display (cont'd)

Symptom	Cause	Inspection	Corrective Actions
		■: Turn OFF the servo system before executing operations.	
Overtravel (OT) (Movement over the zone specified by the host controller)	An overtravel signal is output (P-OT (CN1-16) or N-OT (CN1-17)) is at H.	Check if the voltage of input signal external power supply (+24 V) is correct.	Connect to the external +24 V power supply.
		Check if the overtravel limit switch (SW) operates properly.	Correct the overtravel limit SW.
		Check if the overtravel limit switch (SW) is connected correctly.	Correct the overtravel limit SW wiring.
	The overtravel signal does not operate normally (P-OT or N-OT signal sometimes changes).	Check the fluctuation of the input signal external power supply (+24 V) voltage.	Stabilize the external +24 V power supply voltage.
		Check if the overtravel limit switch (SW) activate correctly.	Adjust the overtravel limit SW so that it operates correctly.
		Check if the overtravel limit switch wiring is correct. (check for damaged cables or loosen screws.)	Correct the overtravel limit SW wiring.
	Incorrect P-OT/N-OT signal selection	Check the P-OT signal selection (Pn50A.3).	Correct the setting of P-OT signal selection (Pn50A.3).
		Check the N-OT signal selection (Pn50B.0).	Correct the setting of N-OT signal selection (Pn50B.0).
	Incorrect servomotor stop method selection	Check if "coast to stop" in servo OFF status is selected.	Check Pn001.0 and Pn001.1.
		Check if "coast to stop" in torque control mode is selected.	Check Pn001.0 and Pn001.1.
	Improper overtravel position setting	The distance to the position of OT (overtravel) is too short considering the coasting distance.	Correct the OT position.
	Noise interference due to improper encoder cable specifications	The encoder cable specifications must be: Twisted-pair or twisted-pair shielded wire with core 0.12 mm ² (0.0002 in ²) min. and tinned annealed copper twisted wire.	Use encoder cable with the specified specifications.
	Noise interference because the encoder cable distance is too long.	The wiring distance must be 20 m (65.6 ft) max.	The encoder cable distance must be within the specified range.
	Noise influence due to damaged encoder cable	Check if the encoder cable is bent or its sheath is damaged.	Correct the encoder cable layout.
	Excessive noise interference to encoder cable	Check if the encoder cable is bundled with a high-current line or near high-current line.	Change the encoder cable layout so that no surge is applied.
	FG electrical potential varies by influence of such machines on the servomotor side as welders.	Check if the machine is correctly grounded.	Ground the machine separately from PG side FG.
SERVOPACK pulse count error due to noise	Check if the signal line from the encoder is influenced by noise.	Take a measure against noise for the encoder wiring.	
Excessive vibration and shock to the encoder	Machine vibration occurred or servomotor mounting such as mounting surface precision, fixing, alignment is incorrect.	Reduce the machine vibration or mount the servomotor securely.	
Encoder fault	An encoder fault occurred.	Replace the servomotor.	
SERVOPACK fault	A SERVOPACK fault occurred.	Replace the SERVOPACK.	
Position error (without alarm)	Unsecured coupling between machine and servomotor	Check if a position error occurs at the coupling between machine and servomotor.	Secure the coupling between the machine and servomotor.
	Noise interference due to improper input signal cable specifications	The input signal cable specifications must be: Twisted-pair or twisted-pair shielded wire with core 0.12 mm ² (0.0002 in ²) min. and tinned annealed copper twisted wire.	Use input signal cable with the specified specifications.
	Noise interference because the input signal cable distance is too long.	The wiring distance must be 3 m (9.84 ft) max. and the impedance several hundreds ohm max.	The input signal cable distance must be within the specified range.
	Encoder fault (pulse count does not change)	An encoder fault occurred. (pulse count does not change)	Replace the servomotor.

Table 10.5 Troubleshooting for Malfunction without Alarm Display (cont'd)

Symptom	Cause	Inspection	Corrective Actions
		■: Turn OFF the servo system before executing operations.	
Servomotor Overheated	Ambient temperature too high	Measure servomotor ambient temperature.	Reduce ambient temperature to 40°C (104 °F) max.
	Servomotor surface dirty	Check visually.	Clean dust and oil from servomotor surface.
	Overloaded	Run under no load.	Reconsider load and operation conditions or replace with larger capacity servomotor.

10.2 Inspection and Maintenance

10.2.1 Servomotor Inspection

The AC servomotors are brushless. Simple, daily inspection is sufficient. The inspection and maintenance frequencies in Table 10.6 are only guidelines. Increase or decrease the frequency to suit the operating conditions and environment.

IMPORTANT

During inspection and maintenance, do not disassemble the servomotor. If disassembly of the servomotor is required, contact your Yaskawa representative.

Table 10.6 Servomotor Inspections

Item	Frequency	Procedure	Comments
Vibration and Noise	Daily	Touch and listen.	Levels higher than normal?
Exterior	According to degree of contamination	Clean with cloth or compressed air.	–
Insulation Resistance Measurement	At least once a year	Disconnect SERVOPACK and test insulation resistance at 500 V. Must exceed 10 MΩ . *	Contact your Yaskawa representative if the insulation resistance is below 10 MΩ .
Replacing Oil Seal	At least once every 5,000 hours	Remove servomotor from machine and replace oil seal.	Applies only to servomotors with oil seals.
Overhaul	At least once every 20,000 hours or 5 years	Contact your Yaskawa representative.	The user should not disassemble and clean the servomotor.

* Measure across the servomotor FG and the phase-U, phase-V, or phase-W power line.

10.2.2 SERVOPACK Inspection

For inspection and maintenance of the SERVOPACK, follow the inspection procedures in Table 10.7 at least once every year. Other routine inspections are not required.

Table 10.7 SERVOPACK Inspections

Item	Frequency	Procedure	Comments
Clean Interior and Circuit Boards	At least once a year	Check for dust, dirt, and oil on the surfaces.	Clean with cloth or compressed air.
Loose Screws		Check for loose terminal block and connector screws.	Tighten any loose screws.
Defective Parts in Unit or on Circuit Boards		Check for discoloration, damage, or discontinuities due to heating.	Contact your Yaskawa representative.

10.2.3 SERVOPACK's Parts Replacement Schedule

The following electric or electronic parts are subject to mechanical wear or deterioration over time. To avoid failure, replace these parts at the frequency indicated.

The parameters of any SERVOPACKs overhauled by Yaskawa are reset to the factory settings before shipping. Be sure to confirm that the parameters are properly set before starting operation.

Table 10.8 Periodical Part Replacement

Part	Standard Replacement Period	Replacement Method	Operating Conditions
Relays	–	Test. Replace if necessary.	<ul style="list-style-type: none"> • Ambient Temperature: Annual average of 30°C • Load Factor: 80% max. • Operation Rate: 20 hours/day max.
Fuses	10 years	Replace with new part.	
Aluminum Electrolytic Capacitor on Circuit Board	5 years	Test. Replace with new circuit board if necessary.	

10.3 Connection to Host Controller

10.3.1 Example of Connection to MP920 4-axes Analog Module SVA-01

MP920 Series SVA-01
manufactured by
Yaskawa

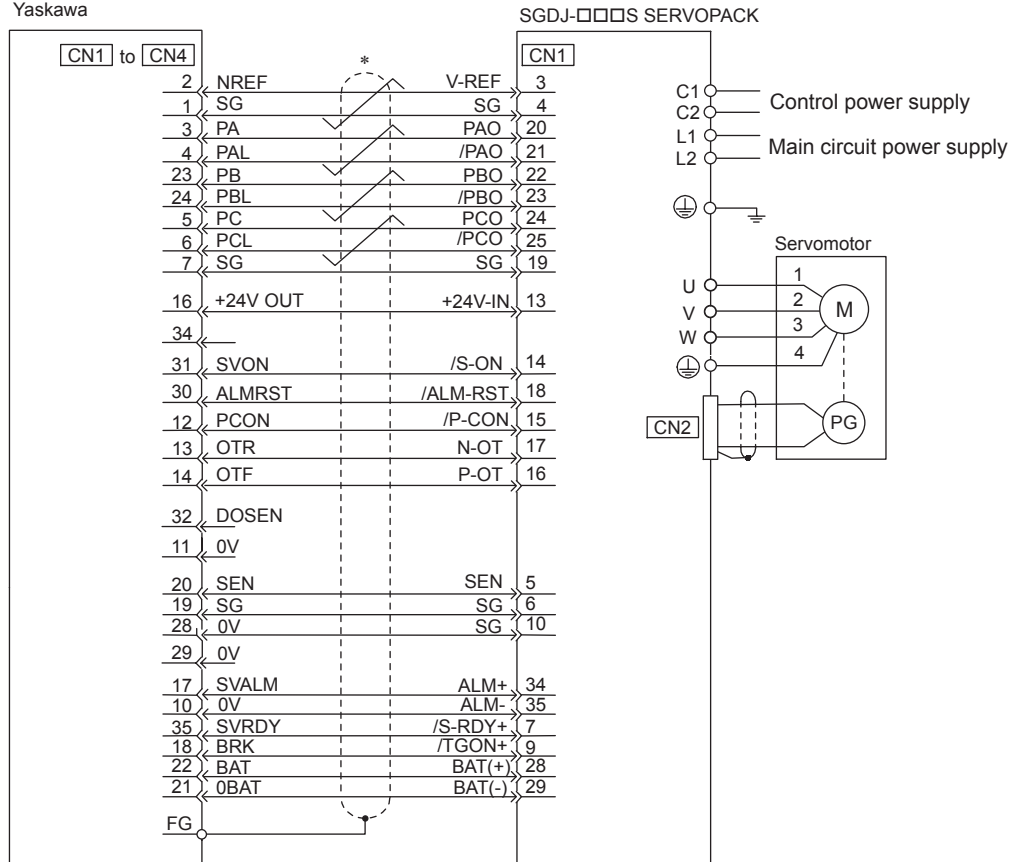

*  represents twisted-pair wires.

10.3.2 Example of Connection to CP-9200SH Servo Controller Module SVA (SERVOPACK in Speed Control Mode)

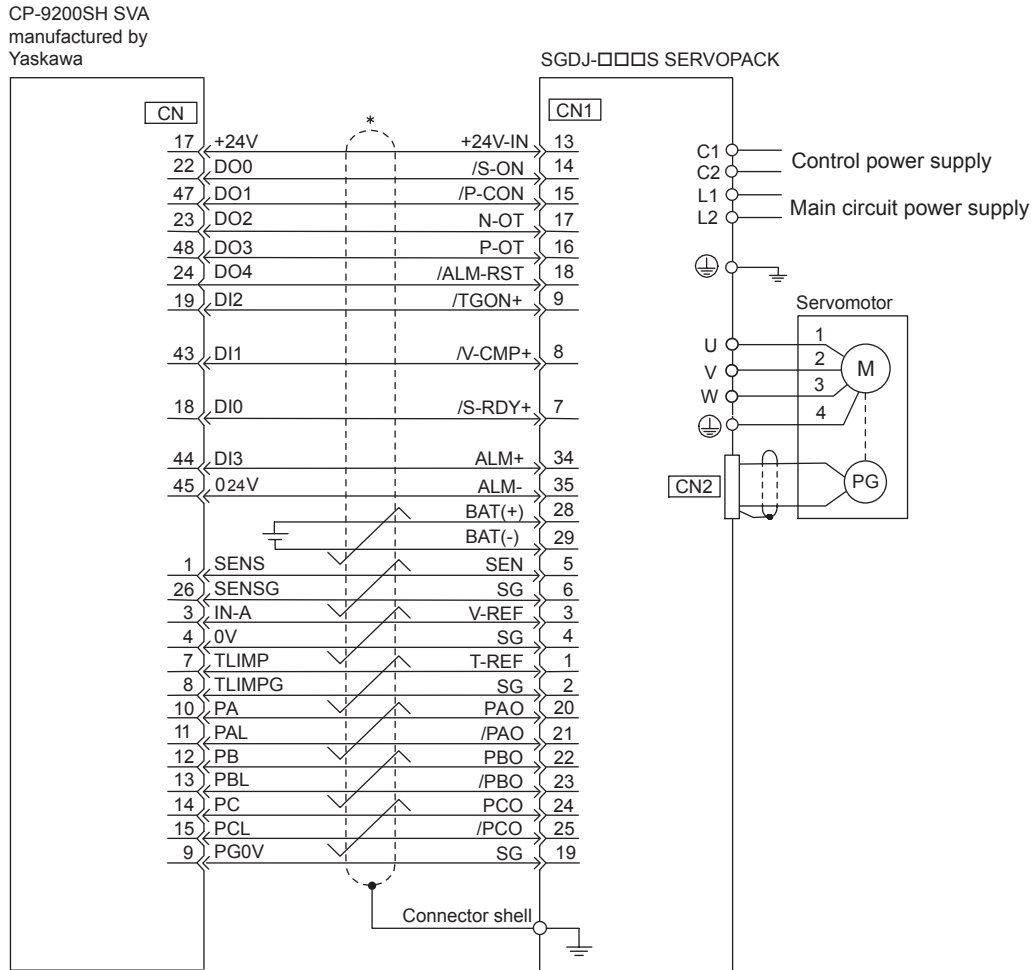

*  represents twisted-pair wires.

10.3.3 Example of Connection to MEMOCON GL120/130 Series Motion Module MC20

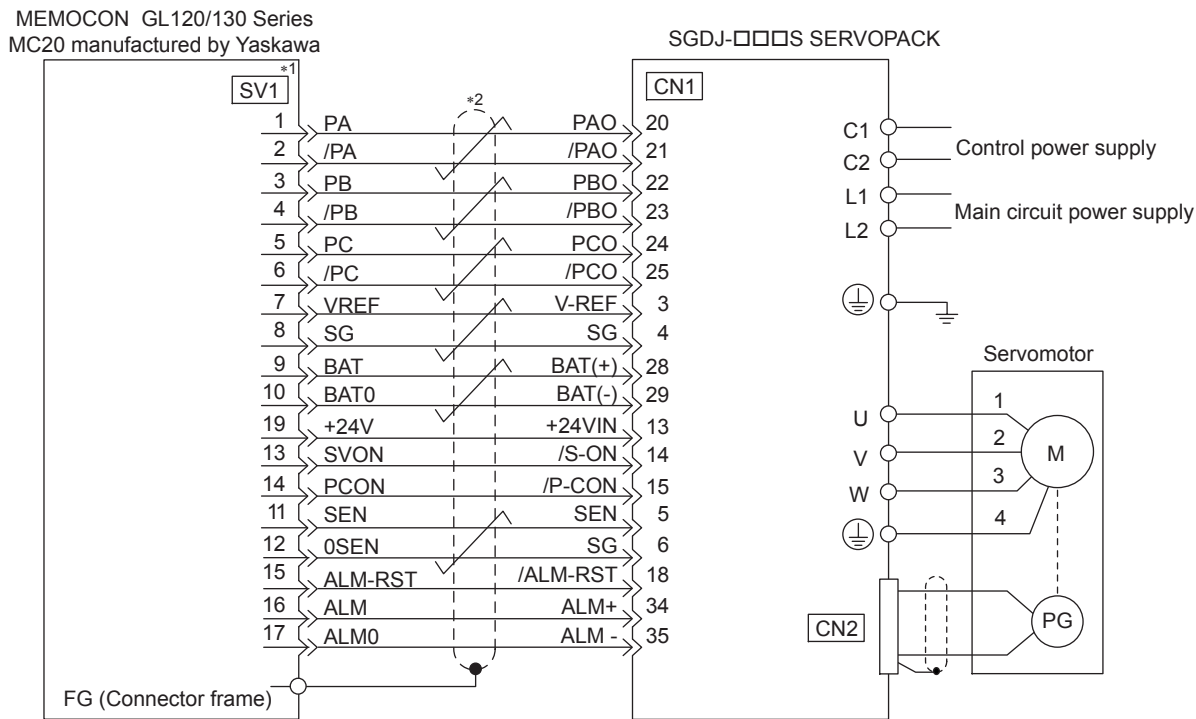

* 1. Pin numbers are the same for SV2 to SV4.

* 2.  represents twisted-pair wires.

10.3.4 Example of Connection to MEMOCON GL60/70 Series Positioning Module B2813 (SERVOPACK in Position Control Mode)

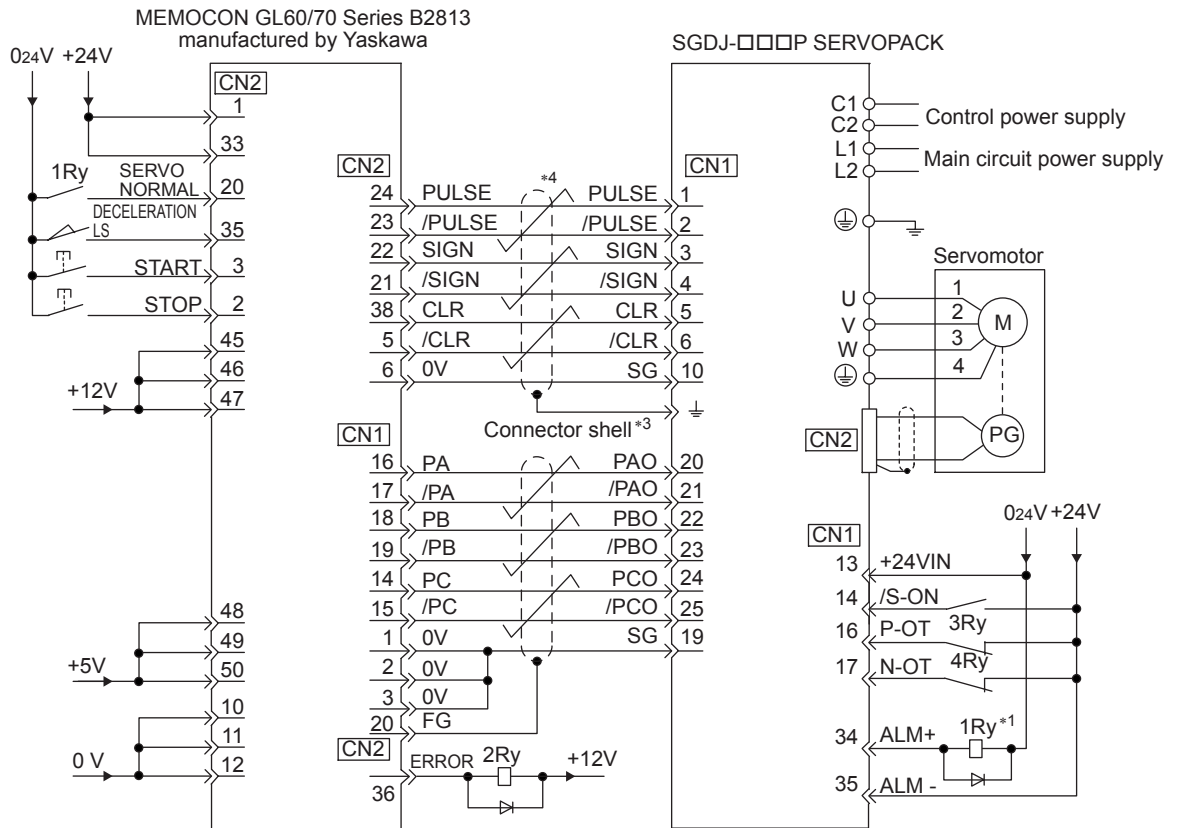

- * 1. The ALM signal is output for approximately two seconds when the power is turned ON. Take this into consideration when designing the power ON sequence. The ALM signal actuates the alarm detection relay 1Ry to stop main circuit power supply to the SERVOPACK.
- * 2. Connect the shield wire to the connector shell.
- * 3.  represents twisted-pair wires.

10.3.5 Example of Connection to OMRON's Motion Control Unit

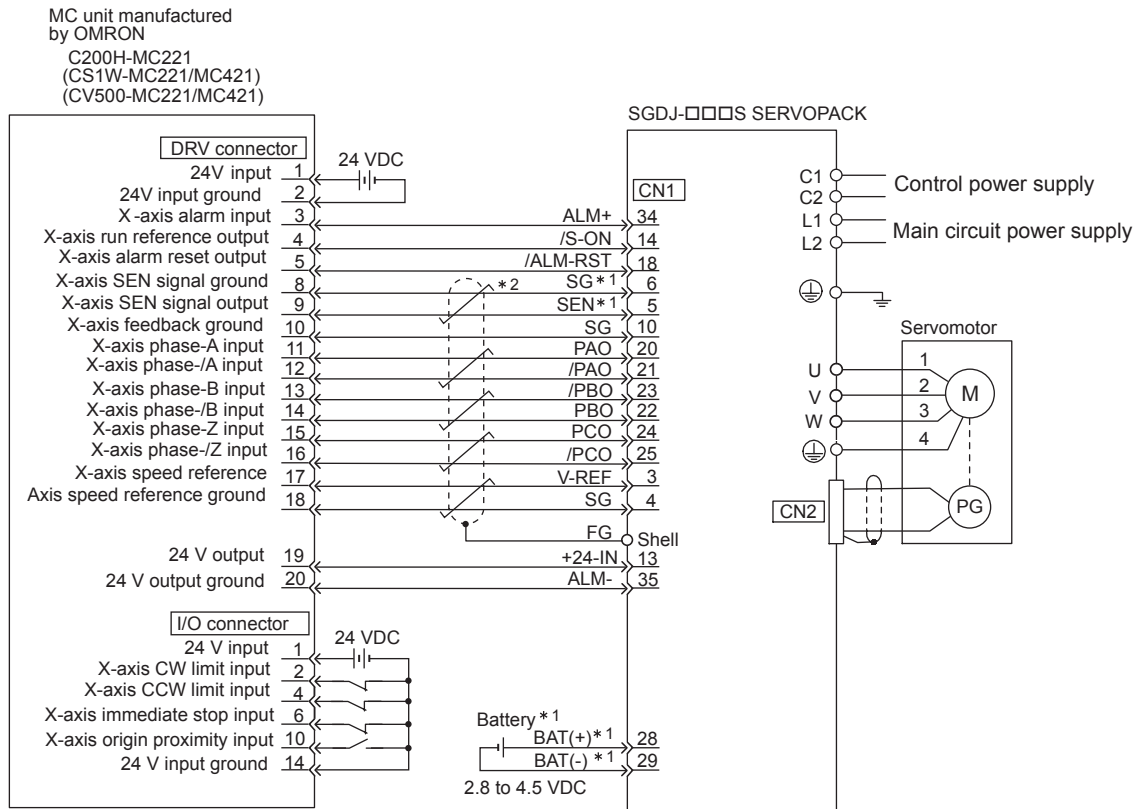



- * 1. Connect when an absolute encoder is used.
- Battery for CN1: ER6VC3 (3.6 V, 2000 mA)

* 2.  represents twisted-pair wires.

- Note:
1. Only signals applicable to OMRON's MC unit and Yaskawa's SGDJ-□□□S SERVOPACK are shown in the diagram.
 2. Note that incorrect signal connection will cause damage to the MC unit and SERVOPACK.
 3. Open the signal lines not to be used.
 4. The above connection diagram shows only X-axis connection. When using another axes, make connection to the SERVOPACK in the same way.
 5. The normally closed (N.C.) input terminals not to be used at the motion control unit I/O connector section must be short-circuited at the connector.
 6. Make the setting so that the servo can be turned ON/OFF by the /S-ON signal.

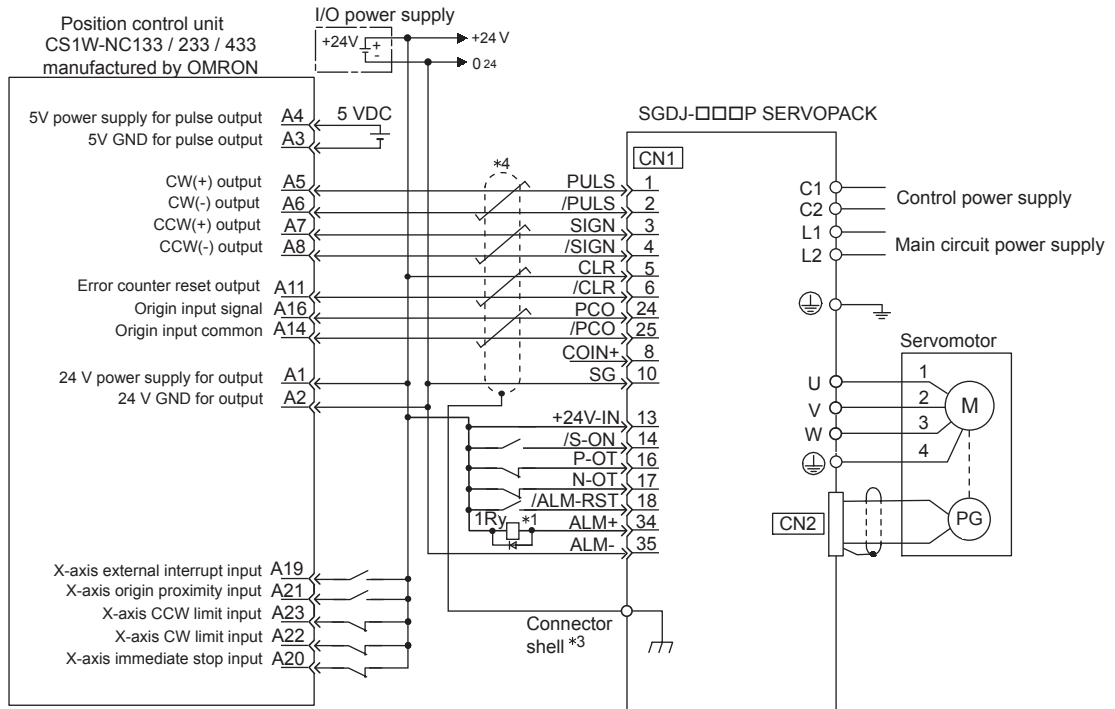
10.3.6 Example of Connection to OMRON's Position Control Unit



- * 1. The ALM signal is output for about two seconds after the control power is turned ON. Take this into consideration when designing the power ON sequence. The ALM signal actuates the alarm detection relay 1Ry to stop the main circuit power supply to the SERVOPACK.
- * 2. Connect the shield wire to the connector shell.
- * 3.  represents twisted-pair wires.

Note: Only signals applicable to OMRON's MC unit (positioning unit) and Yaskawa's SGDJ-SERVOPACK are shown in the diagram.

10.3.7 Example of Connection to OMRON's Position Control Unit C500-NC221 (SERVOPACK in Speed Control Mode)

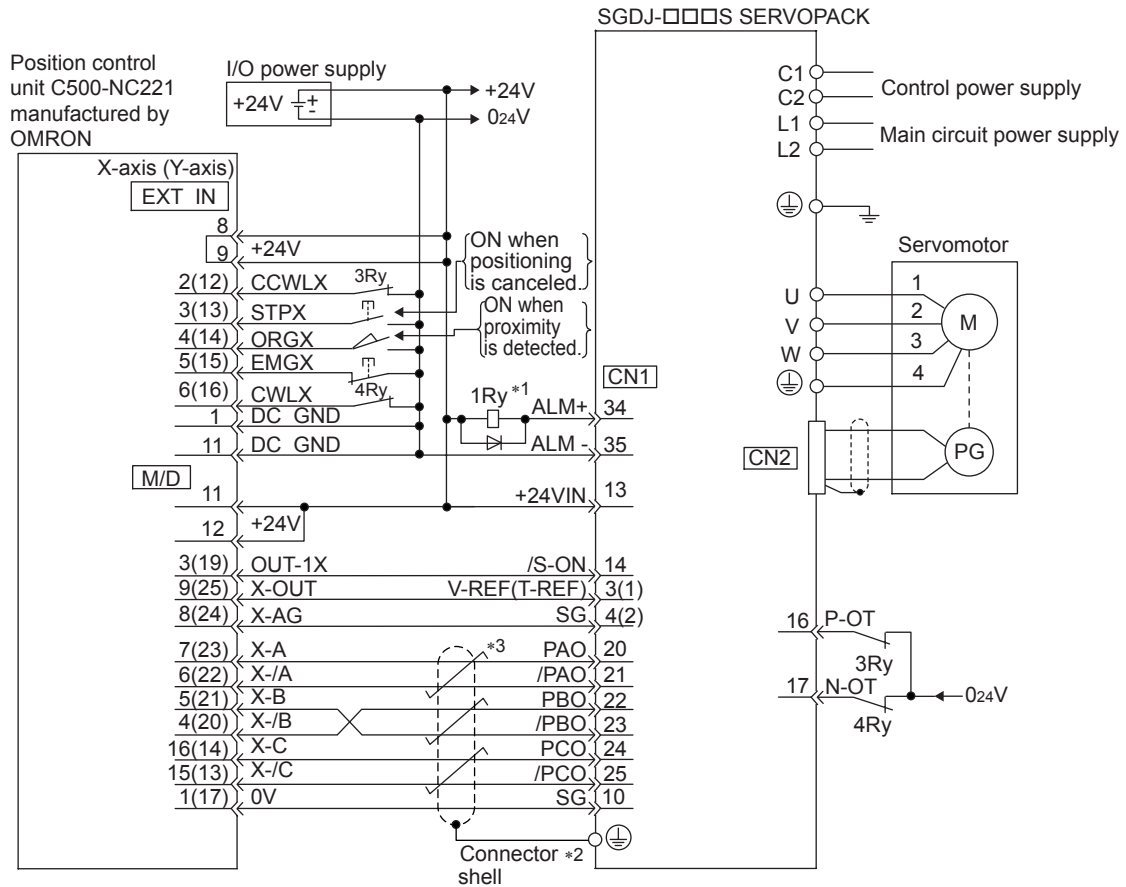

- * 1. The ALM signal is output for approximately two seconds when the control power is turned ON. Take this into consideration when designing the power ON sequence. The ALM signal actuates the alarm detection relay 1Ry to stop main circuit power supply to the SERVOPACK.
- * 2. Connect the I/O cable's shield wire to the connector shell.
- * 3.  represents twisted-pair wires.

Note: Only signals applicable to OMRON's C500-NC221 position control unit and Yaskawa's SGDJ-□□□S SERVOPACK are shown in the diagram.

10.3.8 Example of Connection to OMRON's Position Control Unit C500-NC112 (SERVOPACK in Position Control Mode)

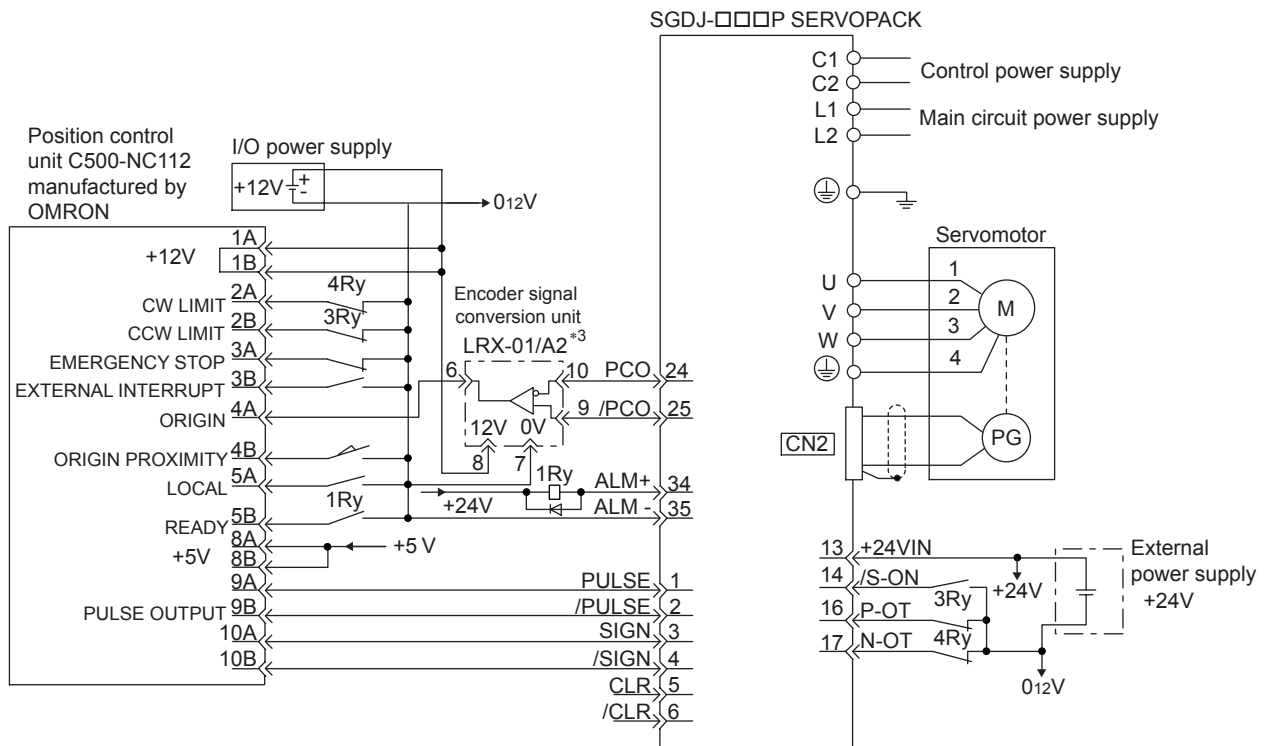



* 1. The ALM signal is output for approximately two seconds when the control power is turned ON. Take this into consideration when designing the power ON sequence. The ALM signal actuates the alarm detection relay 1Ry to stop main circuit power supply to the SERVOPACK.

* 2. Manufactured by Yaskawa Controls Co., Ltd.

Note: Only signals applicable to OMRON's C500-NC112 position control unit and Yaskawa's SGDJ-SERVOPACK are shown in the diagram.

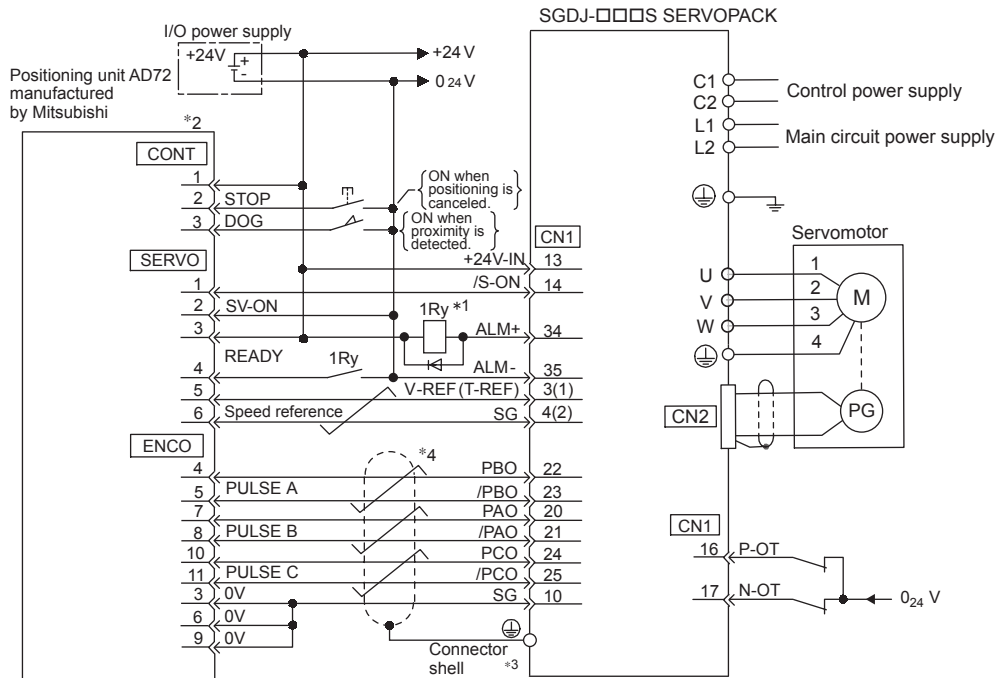
10.3.9 Example of Connection to MITSUBISHI's AD72 Positioning Unit (SERVOPACK in Speed Control Mode)



- * 1. The ALM signal is output for about two seconds after the control power is turned ON. Take this into consideration when designing the power ON sequence. The ALM signal actuates the alarm detection relay 1Ry to stop the main circuit power supply to the SERVOPACK.
- * 2. Pin numbers are the same both for X-axis and Y-axis.
- * 3. Connect the connector wire to the connector shell.
- * 4.  represents twisted-pair wires.

Note: Only signals applicable to Mitsubishi's AD72 Positioning Unit and Yaskawa's SGDJ-SERVOPACK are shown in the diagram.

10.3.10 Example of Connection to MITSUBISHI's AD75 Positioning Unit (SERVOPACK in Position Control Mode)

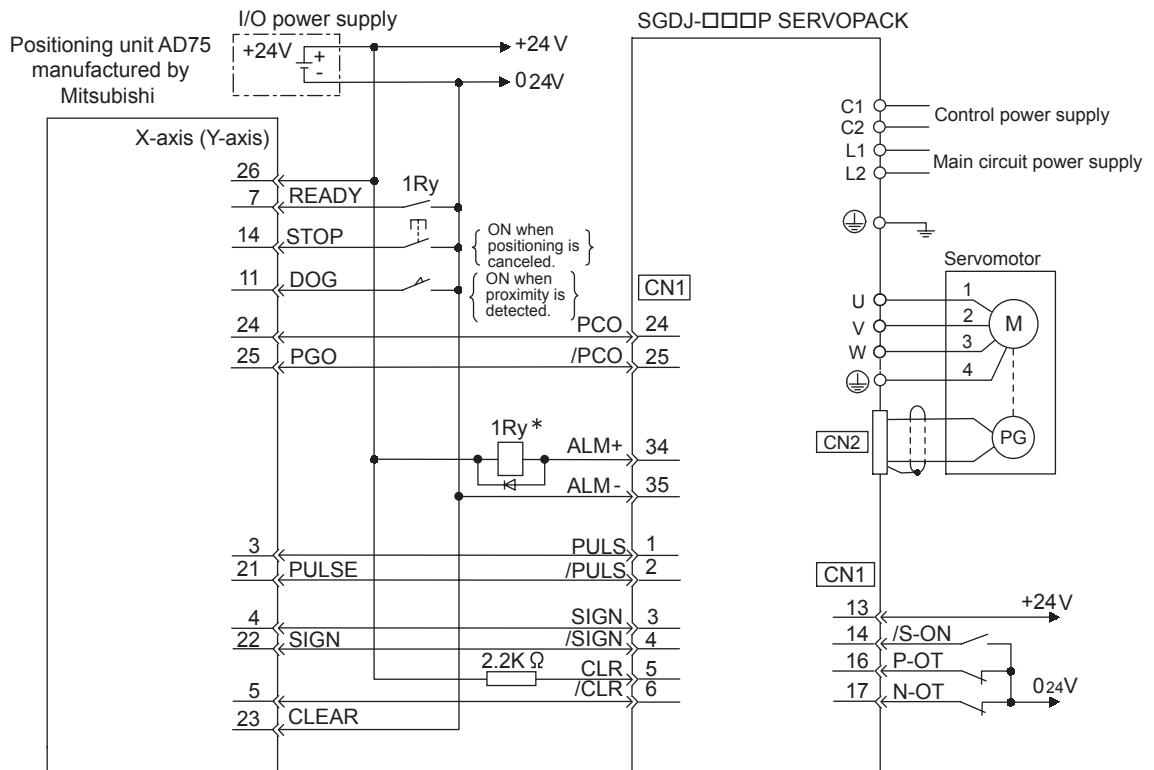

* The ALM signal is output for about two seconds when the control power is turned ON. Take this into consideration when designing the power ON sequence. The ALM signal actuates the alarm detection relay 1Ry to stop the main circuit power supply to the SERVOPACK.

Note: Only signals applicable to Mitsubishi's AD75 Positioning Unit and Yaskawa's SGDJ-SERVOPACK are shown in the diagram.

10.4 List of Parameters

10.4.1 Utility Functions List

The following list shows the available utility functions.

Parameter No.	Function	Remarks	Reference Section
Fn000	Alarm traceback data display	–	7.2.2
Fn001	Rigidity setting during online autotuning	○	9.2.4
Fn002	JOG mode operation	–	8.1.1
Fn003	Zero-point search mode	–	7.2.3
Fn004	Fixed parameter (Do not change.)	–	–
Fn005	Parameter setting initialization	○	7.2.4
Fn006	Alarm traceback data clear	○	7.2.5
Fn007	Writing to EEPROM inertia ratio data obtained from online autotuning	○	9.2.7
Fn008	Absolute encoder multiturn reset and encoder alarm reset	○	8.4.5
Fn009	Automatic tuning of analog (speed, torque) reference offset	○	8.5.3 8.7.3
Fn00A	Manual adjustment of speed reference offset	○	8.5.3
Fn00B	Manual adjustment of torque reference offset	○	8.7.3
Fn00C	Manual zero-adjustment of analog monitor output	○	–
Fn00D	Manual gain-adjustment of analog monitor output	○	–
Fn00E	Automatic offset-adjustment of motor current detection signal	○	7.2.6
Fn00F	Manual offset-adjustment of motor current detection signal	○	7.2.7
Fn010	Password setting (protects parameters from being changed.)	–	7.2.8
Fn011	Motor models display	–	7.2.9
Fn012	Software version display	–	7.2.10
Fn013	Multiturn limit value setting change when a Multiturn Limit Disagreement alarm (A.CC) occurs	○	8.4.8

Note: When the parameters marked with “○” in remarks column are set for Write Prohibited Setting (Fn010), the indication shown below appears and such parameters cannot be changed.

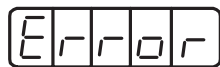

Blinks for
one second

10.4.2 List of Parameters

(1) Parameter Display

Parameter settings are displayed as shown below.



(2) Definition of Display for Function Selection Parameters

Each digit of the function selection parameters has a meaning.

For example, the rightmost digit of parameter Pn000 is expressed as “Pn000.0.”

IMPORTANT

1. Each digit of the function selection parameters is defined as shown below. The following explains the purpose of each digit of a parameter.

- Pn000.0 or n.×××□: Indicates the value for the 1st digit of parameter Pn000.
- Pn000.1 or n.××□×: Indicates the value for the 2nd digit of parameter Pn000.
- Pn000.2 or n.×□××: Indicates the value for the 3rd digit of parameter Pn000.
- Pn000.3 or n.□×××: Indicates the value for the 4th digit of parameter Pn000.

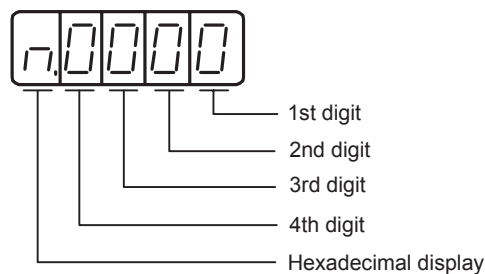

How to Display Parameters

2. After changing the parameters with “After restart” mentioned in “Setting Validation” column in the table on the following pages, turn OFF the main circuit and control power supplies and then turn them ON again to enable the new settings.

10.4.2 List of Parameters

Parameter No.	Name	Setting Range	Units	Factory Setting		Setting Validation	Reference Section																																																																				
				□□□S	□□□P																																																																						
Pn000	Function Selection Basic Switches	–	–	0000	0010	After restart	–																																																																				
<table border="0" style="width: 100%; border-collapse: collapse;"> <tr> <td style="width: 10%; vertical-align: top;">n.</td> <td style="width: 10%; text-align: center;">4th digit</td> <td style="width: 10%; text-align: center;">3rd digit</td> <td style="width: 10%; text-align: center;">2nd digit</td> <td style="width: 10%; text-align: center;">1st digit</td> <td style="width: 50%;"></td> </tr> <tr> <td></td> <td style="text-align: center;">□</td> <td style="text-align: center;">□</td> <td style="text-align: center;">□</td> <td style="text-align: center;">□</td> <td></td> </tr> <tr> <td></td> <td style="border-left: 1px solid black; border-right: 1px solid black; border-bottom: 1px solid black;"></td> <td style="border-left: 1px solid black; border-right: 1px solid black; border-bottom: 1px solid black;"></td> <td style="border-left: 1px solid black; border-right: 1px solid black; border-bottom: 1px solid black;"></td> <td style="border-left: 1px solid black; border-right: 1px solid black; border-bottom: 1px solid black;"></td> <td style="border-left: 1px solid black; border-right: 1px solid black; border-bottom: 1px solid black;"></td> </tr> <tr> <td></td> <td style="border-left: 1px solid black; border-right: 1px solid black;"></td> <td style="border-left: 1px solid black; border-right: 1px solid black;"></td> <td style="border-left: 1px solid black; border-right: 1px solid black;"></td> <td style="border-left: 1px solid black; border-right: 1px solid black;"></td> <td style="border-left: 1px solid black; border-right: 1px solid black;"></td> </tr> </table> <table border="1" style="width: 100%; border-collapse: collapse;"> <thead> <tr style="background-color: #333; color: white;"> <th colspan="2">Direction Selection (Refer to "8.3.2 Switching the Servomotor Rotation Direction.")</th> </tr> </thead> <tbody> <tr> <td style="text-align: center;">0</td> <td>Sets CCW as forward direction.</td> </tr> <tr> <td style="text-align: center;">1</td> <td>Sets CW as forward direction (Reverse Rotation Mode).</td> </tr> <tr> <td style="text-align: center;">2 and 3</td> <td>Reserved (Do not change.)</td> </tr> </tbody> </table> <table border="1" style="width: 100%; border-collapse: collapse;"> <thead> <tr style="background-color: #333; color: white;"> <th colspan="2">Control Method Selection (Refer to "8.2 Control Mode Selection.")</th> </tr> </thead> <tbody> <tr> <td style="text-align: center;">0</td> <td>Speed control (analog reference)</td> </tr> <tr> <td style="text-align: center;">1</td> <td>Position control (pulse train reference)</td> </tr> <tr> <td style="text-align: center;">2</td> <td>Torque control (analog reference)</td> </tr> <tr> <td style="text-align: center;">3</td> <td>Internal set speed control (contact reference)</td> </tr> <tr> <td style="text-align: center;">4</td> <td>Internal set speed control (contact reference) ⇔ Speed control (analog reference)</td> </tr> <tr> <td style="text-align: center;">5</td> <td>Internal set speed control (contact reference) ⇔ Position control (pulse train reference)</td> </tr> <tr> <td style="text-align: center;">6</td> <td>Internal set speed control (contact reference) ⇔ Torque control (analog reference)</td> </tr> <tr> <td style="text-align: center;">7</td> <td>Position control (pulse train reference) ⇔ Speed control (analog reference)</td> </tr> <tr> <td style="text-align: center;">8</td> <td>Position control (pulse train reference) ⇔ Torque control (analog reference)</td> </tr> <tr> <td style="text-align: center;">9</td> <td>Torque control (analog reference) ⇔ Speed control (analog reference)</td> </tr> <tr> <td style="text-align: center;">A</td> <td>Speed control (analog reference) ⇔ Zero clamp</td> </tr> <tr> <td style="text-align: center;">B</td> <td>Position control (pulse train reference) ⇔ Position control (Inhibit)</td> </tr> </tbody> </table> <table border="1" style="width: 100%; border-collapse: collapse;"> <thead> <tr style="background-color: #333; color: white;"> <th colspan="2">Axis Address</th> </tr> </thead> <tbody> <tr> <td style="text-align: center;">0 to F</td> <td>Sets SERVOPACK axis address (Function supported by PC software SigmaWin+).</td> </tr> </tbody> </table> <table border="1" style="width: 100%; border-collapse: collapse;"> <thead> <tr style="background-color: #333; color: white;"> <th colspan="2">Rotation Type/Linear Type Startup Selection (When the Encoder is not Connected)</th> </tr> </thead> <tbody> <tr> <td style="text-align: center;">0</td> <td>Starts up as rotation type.</td> </tr> <tr> <td style="text-align: center;">1</td> <td>Reserved (Do not change)</td> </tr> </tbody> </table>								n.	4th digit	3rd digit	2nd digit	1st digit			□	□	□	□														Direction Selection (Refer to "8.3.2 Switching the Servomotor Rotation Direction.")		0	Sets CCW as forward direction.	1	Sets CW as forward direction (Reverse Rotation Mode).	2 and 3	Reserved (Do not change.)	Control Method Selection (Refer to "8.2 Control Mode Selection.")		0	Speed control (analog reference)	1	Position control (pulse train reference)	2	Torque control (analog reference)	3	Internal set speed control (contact reference)	4	Internal set speed control (contact reference) ⇔ Speed control (analog reference)	5	Internal set speed control (contact reference) ⇔ Position control (pulse train reference)	6	Internal set speed control (contact reference) ⇔ Torque control (analog reference)	7	Position control (pulse train reference) ⇔ Speed control (analog reference)	8	Position control (pulse train reference) ⇔ Torque control (analog reference)	9	Torque control (analog reference) ⇔ Speed control (analog reference)	A	Speed control (analog reference) ⇔ Zero clamp	B	Position control (pulse train reference) ⇔ Position control (Inhibit)	Axis Address		0 to F	Sets SERVOPACK axis address (Function supported by PC software SigmaWin+).	Rotation Type/Linear Type Startup Selection (When the Encoder is not Connected)		0	Starts up as rotation type.	1	Reserved (Do not change)
n.	4th digit	3rd digit	2nd digit	1st digit																																																																							
	□	□	□	□																																																																							
Direction Selection (Refer to "8.3.2 Switching the Servomotor Rotation Direction.")																																																																											
0	Sets CCW as forward direction.																																																																										
1	Sets CW as forward direction (Reverse Rotation Mode).																																																																										
2 and 3	Reserved (Do not change.)																																																																										
Control Method Selection (Refer to "8.2 Control Mode Selection.")																																																																											
0	Speed control (analog reference)																																																																										
1	Position control (pulse train reference)																																																																										
2	Torque control (analog reference)																																																																										
3	Internal set speed control (contact reference)																																																																										
4	Internal set speed control (contact reference) ⇔ Speed control (analog reference)																																																																										
5	Internal set speed control (contact reference) ⇔ Position control (pulse train reference)																																																																										
6	Internal set speed control (contact reference) ⇔ Torque control (analog reference)																																																																										
7	Position control (pulse train reference) ⇔ Speed control (analog reference)																																																																										
8	Position control (pulse train reference) ⇔ Torque control (analog reference)																																																																										
9	Torque control (analog reference) ⇔ Speed control (analog reference)																																																																										
A	Speed control (analog reference) ⇔ Zero clamp																																																																										
B	Position control (pulse train reference) ⇔ Position control (Inhibit)																																																																										
Axis Address																																																																											
0 to F	Sets SERVOPACK axis address (Function supported by PC software SigmaWin+).																																																																										
Rotation Type/Linear Type Startup Selection (When the Encoder is not Connected)																																																																											
0	Starts up as rotation type.																																																																										
1	Reserved (Do not change)																																																																										

Parameter No.	Name	Setting Range	Units	Factory Setting		Setting Validation	Reference Section																																																																							
				□□□S	□□□P																																																																									
Pn001	Function Selection Application Switches 1	—	—	0000	0010	After restart	—																																																																							
<table border="1"> <tr> <td rowspan="4">n.</td> <td>4th digit</td> <td>3rd digit</td> <td>2nd digit</td> <td>1st digit</td> <td></td> </tr> <tr> <td><input type="checkbox"/></td> <td><input type="checkbox"/></td> <td><input type="checkbox"/></td> <td><input type="checkbox"/></td> <td> Servo OFF or Alarm Stop Mode (Refer to "8.3.5 Selecting the Stopping Method After Servo OFF.") </td> </tr> <tr> <td></td> <td></td> <td></td> <td></td> <td> <table border="1"> <tr> <td>0</td> <td>Stops the motor by applying dynamic brake (DB).</td> </tr> <tr> <td>1</td> <td>Stops the motor by applying dynamic brake (DB) and then releases DB.</td> </tr> <tr> <td>2</td> <td>Makes the motor coast to a stop state without using the dynamic brake (DB).</td> </tr> </table> </td> </tr> <tr> <td></td> <td></td> <td></td> <td></td> <td> Overtravel (OT) Stop Mode (Refer to "8.3.3 Setting the Overtravel Limit Function.") </td> </tr> <tr> <td></td> <td></td> <td></td> <td></td> <td></td> <td> <table border="1"> <tr> <td>0</td> <td>Same setting as Pn001.0 (Stops the motor by applying DB or by coasting).</td> </tr> <tr> <td>1</td> <td>Sets the torque of Pn406 to the maximum value, decelerate the motor to a stop, and then sets it to servolock state.</td> </tr> <tr> <td>2</td> <td>Sets the torque of Pn406 to the maximum value, decelerates the motor to a stop, and then sets it to coasting state.</td> </tr> </table> </td> </tr> <tr> <td></td> <td></td> <td></td> <td></td> <td></td> <td> AC/DC Power Input Selection </td> </tr> <tr> <td></td> <td></td> <td></td> <td></td> <td></td> <td> <table border="1"> <tr> <td>0</td> <td>Reserved (Do not change)</td> </tr> <tr> <td>1</td> <td>Applicable to DC power input: Input DC power supply between L1 and L2.</td> </tr> </table> </td> </tr> <tr> <td></td> <td></td> <td></td> <td></td> <td></td> <td> Warning Code Output Selection (Refer to "8.11.2 Warning Output (/WARN).") </td> </tr> <tr> <td></td> <td></td> <td></td> <td></td> <td></td> <td> <table border="1"> <tr> <td>0</td> <td>ALO1, ALO2, and ALO3 output only alarm codes.</td> </tr> <tr> <td>1</td> <td>ALO1, ALO2, and ALO3 output both alarm codes and warning codes. While warning codes are output, ALM signal output remains ON (normal state).</td> </tr> </table> </td> </tr> </table>								n.	4th digit	3rd digit	2nd digit	1st digit		<input type="checkbox"/>	<input type="checkbox"/>	<input type="checkbox"/>	<input type="checkbox"/>	Servo OFF or Alarm Stop Mode (Refer to "8.3.5 Selecting the Stopping Method After Servo OFF.")					<table border="1"> <tr> <td>0</td> <td>Stops the motor by applying dynamic brake (DB).</td> </tr> <tr> <td>1</td> <td>Stops the motor by applying dynamic brake (DB) and then releases DB.</td> </tr> <tr> <td>2</td> <td>Makes the motor coast to a stop state without using the dynamic brake (DB).</td> </tr> </table>	0	Stops the motor by applying dynamic brake (DB).	1	Stops the motor by applying dynamic brake (DB) and then releases DB.	2	Makes the motor coast to a stop state without using the dynamic brake (DB).					Overtravel (OT) Stop Mode (Refer to "8.3.3 Setting the Overtravel Limit Function.")						<table border="1"> <tr> <td>0</td> <td>Same setting as Pn001.0 (Stops the motor by applying DB or by coasting).</td> </tr> <tr> <td>1</td> <td>Sets the torque of Pn406 to the maximum value, decelerate the motor to a stop, and then sets it to servolock state.</td> </tr> <tr> <td>2</td> <td>Sets the torque of Pn406 to the maximum value, decelerates the motor to a stop, and then sets it to coasting state.</td> </tr> </table>	0	Same setting as Pn001.0 (Stops the motor by applying DB or by coasting).	1	Sets the torque of Pn406 to the maximum value, decelerate the motor to a stop, and then sets it to servolock state.	2	Sets the torque of Pn406 to the maximum value, decelerates the motor to a stop, and then sets it to coasting state.						AC/DC Power Input Selection						<table border="1"> <tr> <td>0</td> <td>Reserved (Do not change)</td> </tr> <tr> <td>1</td> <td>Applicable to DC power input: Input DC power supply between L1 and L2.</td> </tr> </table>	0	Reserved (Do not change)	1	Applicable to DC power input: Input DC power supply between L1 and L2.						Warning Code Output Selection (Refer to "8.11.2 Warning Output (/WARN).")						<table border="1"> <tr> <td>0</td> <td>ALO1, ALO2, and ALO3 output only alarm codes.</td> </tr> <tr> <td>1</td> <td>ALO1, ALO2, and ALO3 output both alarm codes and warning codes. While warning codes are output, ALM signal output remains ON (normal state).</td> </tr> </table>	0	ALO1, ALO2, and ALO3 output only alarm codes.	1	ALO1, ALO2, and ALO3 output both alarm codes and warning codes. While warning codes are output, ALM signal output remains ON (normal state).
n.	4th digit	3rd digit	2nd digit	1st digit																																																																										
	<input type="checkbox"/>	<input type="checkbox"/>	<input type="checkbox"/>	<input type="checkbox"/>	Servo OFF or Alarm Stop Mode (Refer to "8.3.5 Selecting the Stopping Method After Servo OFF.")																																																																									
					<table border="1"> <tr> <td>0</td> <td>Stops the motor by applying dynamic brake (DB).</td> </tr> <tr> <td>1</td> <td>Stops the motor by applying dynamic brake (DB) and then releases DB.</td> </tr> <tr> <td>2</td> <td>Makes the motor coast to a stop state without using the dynamic brake (DB).</td> </tr> </table>	0	Stops the motor by applying dynamic brake (DB).		1	Stops the motor by applying dynamic brake (DB) and then releases DB.	2	Makes the motor coast to a stop state without using the dynamic brake (DB).																																																																		
	0	Stops the motor by applying dynamic brake (DB).																																																																												
1	Stops the motor by applying dynamic brake (DB) and then releases DB.																																																																													
2	Makes the motor coast to a stop state without using the dynamic brake (DB).																																																																													
				Overtravel (OT) Stop Mode (Refer to "8.3.3 Setting the Overtravel Limit Function.")																																																																										
					<table border="1"> <tr> <td>0</td> <td>Same setting as Pn001.0 (Stops the motor by applying DB or by coasting).</td> </tr> <tr> <td>1</td> <td>Sets the torque of Pn406 to the maximum value, decelerate the motor to a stop, and then sets it to servolock state.</td> </tr> <tr> <td>2</td> <td>Sets the torque of Pn406 to the maximum value, decelerates the motor to a stop, and then sets it to coasting state.</td> </tr> </table>	0	Same setting as Pn001.0 (Stops the motor by applying DB or by coasting).	1	Sets the torque of Pn406 to the maximum value, decelerate the motor to a stop, and then sets it to servolock state.	2	Sets the torque of Pn406 to the maximum value, decelerates the motor to a stop, and then sets it to coasting state.																																																																			
0	Same setting as Pn001.0 (Stops the motor by applying DB or by coasting).																																																																													
1	Sets the torque of Pn406 to the maximum value, decelerate the motor to a stop, and then sets it to servolock state.																																																																													
2	Sets the torque of Pn406 to the maximum value, decelerates the motor to a stop, and then sets it to coasting state.																																																																													
					AC/DC Power Input Selection																																																																									
					<table border="1"> <tr> <td>0</td> <td>Reserved (Do not change)</td> </tr> <tr> <td>1</td> <td>Applicable to DC power input: Input DC power supply between L1 and L2.</td> </tr> </table>	0	Reserved (Do not change)	1	Applicable to DC power input: Input DC power supply between L1 and L2.																																																																					
0	Reserved (Do not change)																																																																													
1	Applicable to DC power input: Input DC power supply between L1 and L2.																																																																													
					Warning Code Output Selection (Refer to "8.11.2 Warning Output (/WARN).")																																																																									
					<table border="1"> <tr> <td>0</td> <td>ALO1, ALO2, and ALO3 output only alarm codes.</td> </tr> <tr> <td>1</td> <td>ALO1, ALO2, and ALO3 output both alarm codes and warning codes. While warning codes are output, ALM signal output remains ON (normal state).</td> </tr> </table>	0	ALO1, ALO2, and ALO3 output only alarm codes.	1	ALO1, ALO2, and ALO3 output both alarm codes and warning codes. While warning codes are output, ALM signal output remains ON (normal state).																																																																					
0	ALO1, ALO2, and ALO3 output only alarm codes.																																																																													
1	ALO1, ALO2, and ALO3 output both alarm codes and warning codes. While warning codes are output, ALM signal output remains ON (normal state).																																																																													

10.4.2 List of Parameters

Parameter No.	Name	Setting Range	Units	Factory Setting		Setting Validation	Reference Section																																																												
				□□□S	□□□P																																																														
Pn002	Function Selection Application Switches 2	—	—	0000	0000	After restart	—																																																												
<table border="0" style="width: 100%; border-collapse: collapse;"> <tr> <td style="width: 10%; vertical-align: top;">n.</td> <td style="width: 10%; text-align: center;">4th digit</td> <td style="width: 10%; text-align: center;">3rd digit</td> <td style="width: 10%; text-align: center;">2nd digit</td> <td style="width: 10%; text-align: center;">1st digit</td> <td style="width: 50%;"></td> </tr> <tr> <td></td> <td style="text-align: center;">□</td> <td style="text-align: center;">□</td> <td style="text-align: center;">□</td> <td style="text-align: center;">□</td> <td></td> </tr> <tr> <td></td> <td style="border-left: 1px solid black; border-right: 1px solid black; border-bottom: 1px solid black;"></td> <td style="border-left: 1px solid black; border-right: 1px solid black; border-bottom: 1px solid black;"></td> <td style="border-left: 1px solid black; border-right: 1px solid black; border-bottom: 1px solid black;"></td> <td style="border-left: 1px solid black; border-right: 1px solid black; border-bottom: 1px solid black;"></td> <td style="border-left: 1px solid black; border-right: 1px solid black; border-bottom: 1px solid black;"> <table border="1" style="width: 100%; border-collapse: collapse;"> <tr style="background-color: #333; color: white;"> <th colspan="2">Speed Control Option (T-REF Terminal Allocation)</th> </tr> <tr> <td style="text-align: center;">0</td> <td>N/A</td> </tr> <tr> <td style="text-align: center;">1</td> <td>Uses T-REF as an external torque limit input. (Refer to "8.9.3 Torque Limiting Using an Analog Voltage Reference.")</td> </tr> <tr> <td style="text-align: center;">2</td> <td>Uses T-REF as a torque feed forward input. (Refer to "9.4.2 Torque Feed-forward.")</td> </tr> <tr> <td style="text-align: center;">3</td> <td>Uses T-REF as an external torque limit input when P-CL and N-CL are ON. (Refer to "8.9.4 Torque Limiting Using an External Torque Limit and Analog Voltage Reference.")</td> </tr> </table> </td> </tr> <tr> <td></td> <td style="border-left: 1px solid black; border-right: 1px solid black; border-bottom: 1px solid black;"></td> <td style="border-left: 1px solid black; border-right: 1px solid black; border-bottom: 1px solid black;"></td> <td style="border-left: 1px solid black; border-right: 1px solid black; border-bottom: 1px solid black;"></td> <td style="border-left: 1px solid black; border-right: 1px solid black; border-bottom: 1px solid black;"></td> <td style="border-left: 1px solid black; border-right: 1px solid black; border-bottom: 1px solid black;"> <table border="1" style="width: 100%; border-collapse: collapse;"> <tr style="background-color: #333; color: white;"> <th colspan="2">Torque Control Option (V-REF Terminal Allocation) (Refer to "8.7.4 Limiting Servomotor Speed during Torque Control.")</th> </tr> <tr> <td style="text-align: center;">0</td> <td>N/A</td> </tr> <tr> <td style="text-align: center;">1</td> <td>Uses V-REF as an external speed limit input.</td> </tr> </table> </td> </tr> <tr> <td></td> <td style="border-left: 1px solid black; border-right: 1px solid black; border-bottom: 1px solid black;"></td> <td style="border-left: 1px solid black; border-right: 1px solid black; border-bottom: 1px solid black;"></td> <td style="border-left: 1px solid black; border-right: 1px solid black; border-bottom: 1px solid black;"></td> <td style="border-left: 1px solid black; border-right: 1px solid black; border-bottom: 1px solid black;"></td> <td style="border-left: 1px solid black; border-right: 1px solid black; border-bottom: 1px solid black;"> <table border="1" style="width: 100%; border-collapse: collapse;"> <tr style="background-color: #333; color: white;"> <th colspan="2">Absolute Encoder Usage (Refer to "8.4.2 Selecting an Absolute Encoder.")</th> </tr> <tr> <td style="text-align: center;">0</td> <td>Uses absolute encoder as an absolute encoder.</td> </tr> <tr> <td style="text-align: center;">1</td> <td>Uses absolute encoder as an incremental encoder.</td> </tr> </table> </td> </tr> <tr> <td></td> <td style="border-left: 1px solid black; border-right: 1px solid black; border-bottom: 1px solid black;"></td> <td style="border-left: 1px solid black; border-right: 1px solid black; border-bottom: 1px solid black;"></td> <td style="border-left: 1px solid black; border-right: 1px solid black; border-bottom: 1px solid black;"></td> <td style="border-left: 1px solid black; border-right: 1px solid black; border-bottom: 1px solid black;"></td> <td style="border-left: 1px solid black; border-right: 1px solid black; border-bottom: 1px solid black;"> <table border="1" style="width: 100%; border-collapse: collapse;"> <tr style="background-color: #333; color: white;"> <th colspan="2">Reserved (Do not change)</th> </tr> </table> </td> </tr> </table>								n.	4th digit	3rd digit	2nd digit	1st digit			□	□	□	□							<table border="1" style="width: 100%; border-collapse: collapse;"> <tr style="background-color: #333; color: white;"> <th colspan="2">Speed Control Option (T-REF Terminal Allocation)</th> </tr> <tr> <td style="text-align: center;">0</td> <td>N/A</td> </tr> <tr> <td style="text-align: center;">1</td> <td>Uses T-REF as an external torque limit input. (Refer to "8.9.3 Torque Limiting Using an Analog Voltage Reference.")</td> </tr> <tr> <td style="text-align: center;">2</td> <td>Uses T-REF as a torque feed forward input. (Refer to "9.4.2 Torque Feed-forward.")</td> </tr> <tr> <td style="text-align: center;">3</td> <td>Uses T-REF as an external torque limit input when P-CL and N-CL are ON. (Refer to "8.9.4 Torque Limiting Using an External Torque Limit and Analog Voltage Reference.")</td> </tr> </table>	Speed Control Option (T-REF Terminal Allocation)		0	N/A	1	Uses T-REF as an external torque limit input. (Refer to "8.9.3 Torque Limiting Using an Analog Voltage Reference.")	2	Uses T-REF as a torque feed forward input. (Refer to "9.4.2 Torque Feed-forward.")	3	Uses T-REF as an external torque limit input when P-CL and N-CL are ON. (Refer to "8.9.4 Torque Limiting Using an External Torque Limit and Analog Voltage Reference.")						<table border="1" style="width: 100%; border-collapse: collapse;"> <tr style="background-color: #333; color: white;"> <th colspan="2">Torque Control Option (V-REF Terminal Allocation) (Refer to "8.7.4 Limiting Servomotor Speed during Torque Control.")</th> </tr> <tr> <td style="text-align: center;">0</td> <td>N/A</td> </tr> <tr> <td style="text-align: center;">1</td> <td>Uses V-REF as an external speed limit input.</td> </tr> </table>	Torque Control Option (V-REF Terminal Allocation) (Refer to "8.7.4 Limiting Servomotor Speed during Torque Control.")		0	N/A	1	Uses V-REF as an external speed limit input.						<table border="1" style="width: 100%; border-collapse: collapse;"> <tr style="background-color: #333; color: white;"> <th colspan="2">Absolute Encoder Usage (Refer to "8.4.2 Selecting an Absolute Encoder.")</th> </tr> <tr> <td style="text-align: center;">0</td> <td>Uses absolute encoder as an absolute encoder.</td> </tr> <tr> <td style="text-align: center;">1</td> <td>Uses absolute encoder as an incremental encoder.</td> </tr> </table>	Absolute Encoder Usage (Refer to "8.4.2 Selecting an Absolute Encoder.")		0	Uses absolute encoder as an absolute encoder.	1	Uses absolute encoder as an incremental encoder.						<table border="1" style="width: 100%; border-collapse: collapse;"> <tr style="background-color: #333; color: white;"> <th colspan="2">Reserved (Do not change)</th> </tr> </table>	Reserved (Do not change)	
n.	4th digit	3rd digit	2nd digit	1st digit																																																															
	□	□	□	□																																																															
					<table border="1" style="width: 100%; border-collapse: collapse;"> <tr style="background-color: #333; color: white;"> <th colspan="2">Speed Control Option (T-REF Terminal Allocation)</th> </tr> <tr> <td style="text-align: center;">0</td> <td>N/A</td> </tr> <tr> <td style="text-align: center;">1</td> <td>Uses T-REF as an external torque limit input. (Refer to "8.9.3 Torque Limiting Using an Analog Voltage Reference.")</td> </tr> <tr> <td style="text-align: center;">2</td> <td>Uses T-REF as a torque feed forward input. (Refer to "9.4.2 Torque Feed-forward.")</td> </tr> <tr> <td style="text-align: center;">3</td> <td>Uses T-REF as an external torque limit input when P-CL and N-CL are ON. (Refer to "8.9.4 Torque Limiting Using an External Torque Limit and Analog Voltage Reference.")</td> </tr> </table>	Speed Control Option (T-REF Terminal Allocation)		0	N/A	1	Uses T-REF as an external torque limit input. (Refer to "8.9.3 Torque Limiting Using an Analog Voltage Reference.")	2	Uses T-REF as a torque feed forward input. (Refer to "9.4.2 Torque Feed-forward.")	3	Uses T-REF as an external torque limit input when P-CL and N-CL are ON. (Refer to "8.9.4 Torque Limiting Using an External Torque Limit and Analog Voltage Reference.")																																																				
Speed Control Option (T-REF Terminal Allocation)																																																																			
0	N/A																																																																		
1	Uses T-REF as an external torque limit input. (Refer to "8.9.3 Torque Limiting Using an Analog Voltage Reference.")																																																																		
2	Uses T-REF as a torque feed forward input. (Refer to "9.4.2 Torque Feed-forward.")																																																																		
3	Uses T-REF as an external torque limit input when P-CL and N-CL are ON. (Refer to "8.9.4 Torque Limiting Using an External Torque Limit and Analog Voltage Reference.")																																																																		
					<table border="1" style="width: 100%; border-collapse: collapse;"> <tr style="background-color: #333; color: white;"> <th colspan="2">Torque Control Option (V-REF Terminal Allocation) (Refer to "8.7.4 Limiting Servomotor Speed during Torque Control.")</th> </tr> <tr> <td style="text-align: center;">0</td> <td>N/A</td> </tr> <tr> <td style="text-align: center;">1</td> <td>Uses V-REF as an external speed limit input.</td> </tr> </table>	Torque Control Option (V-REF Terminal Allocation) (Refer to "8.7.4 Limiting Servomotor Speed during Torque Control.")		0	N/A	1	Uses V-REF as an external speed limit input.																																																								
Torque Control Option (V-REF Terminal Allocation) (Refer to "8.7.4 Limiting Servomotor Speed during Torque Control.")																																																																			
0	N/A																																																																		
1	Uses V-REF as an external speed limit input.																																																																		
					<table border="1" style="width: 100%; border-collapse: collapse;"> <tr style="background-color: #333; color: white;"> <th colspan="2">Absolute Encoder Usage (Refer to "8.4.2 Selecting an Absolute Encoder.")</th> </tr> <tr> <td style="text-align: center;">0</td> <td>Uses absolute encoder as an absolute encoder.</td> </tr> <tr> <td style="text-align: center;">1</td> <td>Uses absolute encoder as an incremental encoder.</td> </tr> </table>	Absolute Encoder Usage (Refer to "8.4.2 Selecting an Absolute Encoder.")		0	Uses absolute encoder as an absolute encoder.	1	Uses absolute encoder as an incremental encoder.																																																								
Absolute Encoder Usage (Refer to "8.4.2 Selecting an Absolute Encoder.")																																																																			
0	Uses absolute encoder as an absolute encoder.																																																																		
1	Uses absolute encoder as an incremental encoder.																																																																		
					<table border="1" style="width: 100%; border-collapse: collapse;"> <tr style="background-color: #333; color: white;"> <th colspan="2">Reserved (Do not change)</th> </tr> </table>	Reserved (Do not change)																																																													
Reserved (Do not change)																																																																			

Parameter No.	Name	Setting Range	Units	Factory Setting		Setting Validation	Reference Section																				
				□□□S	□□□P																						
Pn003	Function Selection Application Switches 3	—	—	0002	0002	Immediately	—																				
n.	<div style="display: flex; justify-content: space-around; margin-bottom: 5px;"> 4th digit 3rd digit 2nd digit 1st digit </div> <div style="display: flex; justify-content: space-around; margin-bottom: 5px;"> <input type="checkbox"/> <input type="checkbox"/> <input type="checkbox"/> <input type="checkbox"/> </div> <div style="display: flex; justify-content: space-between;"> <div style="width: 20%; border-left: 1px solid black; border-right: 1px solid black; padding: 5px;"> Analog Monitor 1 Torque Reference Monitor (Refer to "9.5 Analog Monitor.") </div> <table border="1" style="width: 80%; border-collapse: collapse;"> <tr><td>0</td><td>Motor speed: 1 V/1000 min⁻¹</td></tr> <tr><td>1</td><td>Speed reference: 1 V/1000 min⁻¹</td></tr> <tr><td>2</td><td>Torque reference: 1 V/100%</td></tr> <tr><td>3</td><td>Position error: 0.05 V/1 reference unit *</td></tr> <tr><td>4</td><td>Position error: 0.05 V/100 reference units *</td></tr> <tr><td>5</td><td>Reference pulse frequency (converted to min⁻¹): 1 V/1000 min⁻¹</td></tr> <tr><td>6</td><td>Motor speed × 4: 1 V/250 min⁻¹</td></tr> <tr><td>7</td><td>Motor speed × 8: 1 V/150 min⁻¹</td></tr> <tr><td>8 to F</td><td>Reserved (Do not change)</td></tr> </table> </div> <div style="display: flex; justify-content: space-between; margin-top: 10px;"> <div style="width: 20%; border-left: 1px solid black; border-right: 1px solid black; padding: 5px;"> Analog Monitor 2 Speed Reference Monitor (Refer to "9.5 Analog Monitor.") </div> <table border="1" style="width: 80%; border-collapse: collapse;"> <tr><td>0 to F</td><td>Same as Analog Monitor 1 Torque Reference Monitor</td></tr> </table> </div> <div style="display: flex; justify-content: space-between; margin-top: 10px;"> <div style="width: 20%; border-left: 1px solid black; border-right: 1px solid black; padding: 5px;"> Reserved (Do not change) </div> </div> <div style="display: flex; justify-content: space-between; margin-top: 10px;"> <div style="width: 20%; border-left: 1px solid black; border-right: 1px solid black; padding: 5px;"> Reserved (Do not change) </div> </div>	0	Motor speed: 1 V/1000 min ⁻¹	1	Speed reference: 1 V/1000 min ⁻¹	2	Torque reference: 1 V/100%	3	Position error: 0.05 V/1 reference unit *	4	Position error: 0.05 V/100 reference units *	5	Reference pulse frequency (converted to min ⁻¹): 1 V/1000 min ⁻¹	6	Motor speed × 4: 1 V/250 min ⁻¹	7	Motor speed × 8: 1 V/150 min ⁻¹	8 to F	Reserved (Do not change)	0 to F	Same as Analog Monitor 1 Torque Reference Monitor	—	—	0000	0000	Immediately	—
	0	Motor speed: 1 V/1000 min ⁻¹																									
	1	Speed reference: 1 V/1000 min ⁻¹																									
	2	Torque reference: 1 V/100%																									
	3	Position error: 0.05 V/1 reference unit *																									
	4	Position error: 0.05 V/100 reference units *																									
	5	Reference pulse frequency (converted to min ⁻¹): 1 V/1000 min ⁻¹																									
	6	Motor speed × 4: 1 V/250 min ⁻¹																									
	7	Motor speed × 8: 1 V/150 min ⁻¹																									
	8 to F	Reserved (Do not change)																									
0 to F	Same as Analog Monitor 1 Torque Reference Monitor																										
Pn004	Reserved (Do not change)	—	—	0000	0000	Immediately	—																				
Pn005	Reserved (Do not change)	—	—	0000	0000	Immediately	—																				
Pn100	Speed Loop Gain	1 to 2000 Hz	1 Hz	40	40	Immediately	9.3.4																				
Pn101	Speed Loop Integral Time Constant	0.15 to 512.00 ms	0.01 ms	2000	2000	Immediately	9.3.5																				
Pn102	Position Loop Gain *	1 to 2000/s	1/s	—	40	Immediately	9.3.3																				
Pn103	Moment of Inertia Ratio	0 to 10000%	1%	0	0	Immediately	9.2.6 9.3.3																				
Pn104	2nd Speed Loop Gain	1 to 2000 Hz	1 Hz	40	40	Immediately	9.4.8																				
Pn105	2nd Speed Loop Integral Time Constant	0.15 to 512.00 ms	0.01 ms	2000	2000	Immediately	9.4.8																				
Pn106	2nd Position Loop Gain *	1 to 2000/s	1/s	—	40	Immediately	9.4.8																				
Pn107	Bias *	0 to 450 min ⁻¹	1 min ⁻¹	—	0	Immediately	9.4.5																				
Pn108	Bias Width Addition *	0 to 250 reference units	Reference unit	0	7	Immediately	9.4.5																				
Pn109	Feed-forward *	0 to 100%	1%	—	0	Immediately	9.4.1																				

* Used only for SGDJ-□□□P SERVOPACK for position control mode.

10.4.2 List of Parameters

Parameter No.	Name	Setting Range	Units	Factory Setting		Setting Validation	Reference Section																																													
				□□□S	□□□P																																															
Pn10A	Feed-forward Filter Time Constant	0.00 to 64.00 ms	0.01 ms	–	0	Immediately	9.4.1																																													
Pn10B	Gain-related Application Switches	–	–	0000	0000	After restart/ Immediately	–																																													
	<div style="display: flex; align-items: flex-start;"> <div style="margin-right: 10px;"> <p>n. <input type="checkbox"/> <input type="checkbox"/> <input type="checkbox"/> <input type="checkbox"/></p> <p style="font-size: small;">4th digit 3rd digit 2nd digit 1st digit</p> </div> <table border="1" style="width: 100%; border-collapse: collapse;"> <thead> <tr style="background-color: #f2f2f2;"> <th colspan="2">Mode Switch Selection (Refer to "9.4.4 Using the Mode Switch (P/PI Switching).")</th> <th>Setting Validation</th> </tr> </thead> <tbody> <tr> <td style="text-align: center;">0</td> <td>Uses internal torque reference as the condition (Level setting: Pn10C)</td> <td>Immediately</td> </tr> <tr> <td style="text-align: center;">1</td> <td>Uses speed reference as the condition (Level setting: Pn10D)</td> <td>Immediately</td> </tr> <tr> <td style="text-align: center;">2</td> <td>Uses acceleration as the condition (Level setting: Pn10E)</td> <td>Immediately</td> </tr> <tr> <td style="text-align: center;">3</td> <td>Uses position error pulse as the condition (Level setting: Pn10F)</td> <td>Immediately</td> </tr> <tr> <td style="text-align: center;">4</td> <td>No mode switch function available</td> <td>Immediately</td> </tr> </tbody> </table> <table border="1" style="width: 100%; border-collapse: collapse;"> <thead> <tr style="background-color: #f2f2f2;"> <th colspan="2">Speed Loop Control Method (Refer to "9.3.5 Speed Loop Integral Time Constant.")</th> <th>Setting Validation</th> </tr> </thead> <tbody> <tr> <td style="text-align: center;">0</td> <td>PI control</td> <td>After restart</td> </tr> <tr> <td style="text-align: center;">1</td> <td>IP control</td> <td>After restart</td> </tr> <tr> <td style="text-align: center;">2 and 3</td> <td>Reserved (Do not change)</td> <td>After restart</td> </tr> </tbody> </table> <table border="1" style="width: 100%; border-collapse: collapse;"> <thead> <tr style="background-color: #f2f2f2;"> <th colspan="2">Automatic Gain Switching Condition Selection * (Refer to "9.4.8 Switching Gain Settings.")</th> <th>Setting Validation</th> </tr> </thead> <tbody> <tr> <td style="text-align: center;">0</td> <td>Automatic gain switching disabled (Factory setting)</td> <td>After restart</td> </tr> <tr> <td style="text-align: center;">1</td> <td>Switches the gain according to the position reference condition only.</td> <td>After restart</td> </tr> <tr> <td style="text-align: center;">2</td> <td>Switches the gain according to the position error condition only.</td> <td>After restart</td> </tr> <tr> <td style="text-align: center;">3</td> <td>Switches the gain according to the position reference and position error condition only.</td> <td>After restart</td> </tr> </tbody> </table> <div style="background-color: #f2f2f2; padding: 5px; text-align: center;">Reserved (Do not change)</div> </div>							Mode Switch Selection (Refer to "9.4.4 Using the Mode Switch (P/PI Switching).")		Setting Validation	0	Uses internal torque reference as the condition (Level setting: Pn10C)	Immediately	1	Uses speed reference as the condition (Level setting: Pn10D)	Immediately	2	Uses acceleration as the condition (Level setting: Pn10E)	Immediately	3	Uses position error pulse as the condition (Level setting: Pn10F)	Immediately	4	No mode switch function available	Immediately	Speed Loop Control Method (Refer to "9.3.5 Speed Loop Integral Time Constant.")		Setting Validation	0	PI control	After restart	1	IP control	After restart	2 and 3	Reserved (Do not change)	After restart	Automatic Gain Switching Condition Selection * (Refer to "9.4.8 Switching Gain Settings.")		Setting Validation	0	Automatic gain switching disabled (Factory setting)	After restart	1	Switches the gain according to the position reference condition only.	After restart	2	Switches the gain according to the position error condition only.	After restart	3	Switches the gain according to the position reference and position error condition only.	After restart
	Mode Switch Selection (Refer to "9.4.4 Using the Mode Switch (P/PI Switching).")		Setting Validation																																																	
	0	Uses internal torque reference as the condition (Level setting: Pn10C)	Immediately																																																	
	1	Uses speed reference as the condition (Level setting: Pn10D)	Immediately																																																	
	2	Uses acceleration as the condition (Level setting: Pn10E)	Immediately																																																	
	3	Uses position error pulse as the condition (Level setting: Pn10F)	Immediately																																																	
	4	No mode switch function available	Immediately																																																	
	Speed Loop Control Method (Refer to "9.3.5 Speed Loop Integral Time Constant.")		Setting Validation																																																	
	0	PI control	After restart																																																	
1	IP control	After restart																																																		
2 and 3	Reserved (Do not change)	After restart																																																		
Automatic Gain Switching Condition Selection * (Refer to "9.4.8 Switching Gain Settings.")		Setting Validation																																																		
0	Automatic gain switching disabled (Factory setting)	After restart																																																		
1	Switches the gain according to the position reference condition only.	After restart																																																		
2	Switches the gain according to the position error condition only.	After restart																																																		
3	Switches the gain according to the position reference and position error condition only.	After restart																																																		
Pn10C	Mode Switch Torque Reference	0 to 800%	1%	200	200	Immediately	9.4.4																																													
Pn10D	Mode Switch Speed Reference	0 to 10000 min ⁻¹	1 min ⁻¹	0	0	Immediately	9.4.4																																													
Pn10E	Mode Switch Acceleration	0 to 3000 min ⁻¹ /s	1 min ⁻¹ /s	0	0	Immediately	9.4.4																																													
Pn10F	Mode Switch Error Pulse *	0 to 10000 reference units	1 reference unit	–	0	Immediately	9.4.4																																													

* Used only for SGDJ-□□□P SERVOPACK for position control mode.

Parameter No.	Name	Setting Range	Units	Factory Setting		Setting Validation	Reference Section																															
				□□□S	□□□P																																	
Pn110	Online Autotuning Switches	–	–	0010	0010	After restart/ Immediately	–																															
	<div style="display: flex; align-items: flex-start;"> <div style="margin-right: 10px;"> <p>n. <input type="checkbox"/> <input type="checkbox"/> <input type="checkbox"/> <input type="checkbox"/></p> <p style="font-size: small;">4th digit 3rd digit 2nd digit 1st digit</p> </div> <table border="1" style="width: 100%; border-collapse: collapse;"> <tr style="background-color: #333; color: white;"> <th colspan="2">Online Autotuning Method (Refer to "9.2.3 Selecting the Online Autotuning Execution Method.")</th> <th>Setting Validation</th> </tr> <tr> <td style="text-align: center;">0</td> <td>Tunes only at the beginning of operation.</td> <td rowspan="3" style="text-align: center; vertical-align: middle;">After restart</td> </tr> <tr> <td style="text-align: center;">1</td> <td>Always tunes.</td> </tr> <tr> <td style="text-align: center;">2</td> <td>Does not perform autotuning.</td> </tr> <tr style="background-color: #333; color: white;"> <th colspan="2">Speed Feedback Compensation Selection (Refer to "9.4.7 Speed Feedback Compensation.")</th> <th>Setting Validation</th> </tr> <tr> <td style="text-align: center;">0</td> <td>Applicable</td> <td rowspan="2" style="text-align: center; vertical-align: middle;">Immediately</td> </tr> <tr> <td style="text-align: center;">1</td> <td>N/A</td> </tr> <tr style="background-color: #333; color: white;"> <th colspan="2">Friction Compensation Selection</th> <th>Setting Validation</th> </tr> <tr> <td style="text-align: center;">0</td> <td>Friction compensation: Disabled</td> <td rowspan="3" style="text-align: center; vertical-align: middle;">Immediately</td> </tr> <tr> <td style="text-align: center;">1</td> <td>Friction compensation: Small</td> </tr> <tr> <td style="text-align: center;">2</td> <td>Friction compensation: Large</td> </tr> <tr style="background-color: #333; color: white;"> <td colspan="3" style="text-align: center;">Reserved (Do not change)</td> </tr> </table> </div>							Online Autotuning Method (Refer to "9.2.3 Selecting the Online Autotuning Execution Method.")		Setting Validation	0	Tunes only at the beginning of operation.	After restart	1	Always tunes.	2	Does not perform autotuning.	Speed Feedback Compensation Selection (Refer to "9.4.7 Speed Feedback Compensation.")		Setting Validation	0	Applicable	Immediately	1	N/A	Friction Compensation Selection		Setting Validation	0	Friction compensation: Disabled	Immediately	1	Friction compensation: Small	2	Friction compensation: Large	Reserved (Do not change)		
Online Autotuning Method (Refer to "9.2.3 Selecting the Online Autotuning Execution Method.")		Setting Validation																																				
0	Tunes only at the beginning of operation.	After restart																																				
1	Always tunes.																																					
2	Does not perform autotuning.																																					
Speed Feedback Compensation Selection (Refer to "9.4.7 Speed Feedback Compensation.")		Setting Validation																																				
0	Applicable	Immediately																																				
1	N/A																																					
Friction Compensation Selection		Setting Validation																																				
0	Friction compensation: Disabled	Immediately																																				
1	Friction compensation: Small																																					
2	Friction compensation: Large																																					
Reserved (Do not change)																																						
Pn111	Speed Feedback Compensation *	1 to 500%	1%	100	100	Immediately	9.4.7																															
Pn112	Reserved (Do not change)	–	–	100	100	–	–																															
Pn113				1000	1000																																	
Pn114				200	200																																	
Pn115				32	32																																	
Pn116				16	16																																	
Pn117				100	100																																	
Pn118				100	100																																	
Pn119				50	50																																	
Pn11A				1000	1000																																	
Pn11B				50	50																																	
Pn11C				70	70																																	
Pn11D				100	100																																	
Pn11E				100	100																																	
Pn11F				0	0																																	
Pn120				0	0																																	
Pn121				50	50																																	
Pn122	0	0																																				
Pn123	0	0																																				

* The parameter Pn111 setting is enabled only when the parameter Pn110.1 is set to 0.

10.4.2 List of Parameters

Parameter No.	Name	Setting Range	Units	Factory Setting		Setting Validation	Reference Section																																														
				□□□S	□□□P																																																
Pn200	Position Control References Selection Switches *1	—	—	0000	0000	After restart	8.6.1																																														
<div style="display: flex; align-items: flex-start;"> <div style="margin-right: 20px;"> <p>n. <input type="checkbox"/> <input type="checkbox"/> <input type="checkbox"/> <input type="checkbox"/></p> <p style="font-size: small;">4th digit 3rd digit 2nd digit 1st digit</p> </div> <div> <table border="1" style="width: 100%; border-collapse: collapse;"> <thead> <tr style="background-color: #333; color: white;"> <th colspan="2">Reference Pulse Form</th> </tr> </thead> <tbody> <tr><td>0</td><td>Sign + Pulse, positive logic</td></tr> <tr><td>1</td><td>CW + CCW, positive logic</td></tr> <tr><td>2</td><td>Phase A + Phase B (×1), positive logic</td></tr> <tr><td>3</td><td>Phase A + Phase B (×2), positive logic</td></tr> <tr><td>4</td><td>Phase A + Phase B (×4), positive logic</td></tr> <tr><td>5</td><td>Sign + Pulse, negative logic</td></tr> <tr><td>6</td><td>CW + CCW, negative logic</td></tr> <tr><td>7</td><td>Phase A + Phase B (×1), negative logic</td></tr> <tr><td>8</td><td>Phase A + Phase B (×2), negative logic</td></tr> <tr><td>9</td><td>Phase A + Phase B (×4), negative logic</td></tr> </tbody> </table> <table border="1" style="width: 100%; border-collapse: collapse;"> <thead> <tr style="background-color: #333; color: white;"> <th colspan="2">Error Counter Clear Signal From</th> </tr> </thead> <tbody> <tr><td>0</td><td>Clears error counter when the signal is at H level.</td></tr> <tr><td>1</td><td>Clears error counter at the rising edge of the signal.</td></tr> <tr><td>2</td><td>Clears error counter when the signal is at L level.</td></tr> <tr><td>3</td><td>Clears error counter at the falling edge of the signal.</td></tr> </tbody> </table> <table border="1" style="width: 100%; border-collapse: collapse;"> <thead> <tr style="background-color: #333; color: white;"> <th colspan="2">Clear Operation</th> </tr> </thead> <tbody> <tr><td>0</td><td>Clears error counter at the baseblock.</td></tr> <tr><td>1</td><td>Does not clear error counter (Possible to clear error counter only with CLR signal).</td></tr> <tr><td>2</td><td>Clears error counter when an alarm occurs.</td></tr> </tbody> </table> <table border="1" style="width: 100%; border-collapse: collapse;"> <thead> <tr style="background-color: #333; color: white;"> <th colspan="2">Filter Selection</th> </tr> </thead> <tbody> <tr><td>0</td><td>Reference input filter for line driver signals</td></tr> <tr><td>1</td><td>Reference input filter for open collector signals</td></tr> </tbody> </table> </div> </div>								Reference Pulse Form		0	Sign + Pulse, positive logic	1	CW + CCW, positive logic	2	Phase A + Phase B (×1), positive logic	3	Phase A + Phase B (×2), positive logic	4	Phase A + Phase B (×4), positive logic	5	Sign + Pulse, negative logic	6	CW + CCW, negative logic	7	Phase A + Phase B (×1), negative logic	8	Phase A + Phase B (×2), negative logic	9	Phase A + Phase B (×4), negative logic	Error Counter Clear Signal From		0	Clears error counter when the signal is at H level.	1	Clears error counter at the rising edge of the signal.	2	Clears error counter when the signal is at L level.	3	Clears error counter at the falling edge of the signal.	Clear Operation		0	Clears error counter at the baseblock.	1	Does not clear error counter (Possible to clear error counter only with CLR signal).	2	Clears error counter when an alarm occurs.	Filter Selection		0	Reference input filter for line driver signals	1	Reference input filter for open collector signals
Reference Pulse Form																																																					
0	Sign + Pulse, positive logic																																																				
1	CW + CCW, positive logic																																																				
2	Phase A + Phase B (×1), positive logic																																																				
3	Phase A + Phase B (×2), positive logic																																																				
4	Phase A + Phase B (×4), positive logic																																																				
5	Sign + Pulse, negative logic																																																				
6	CW + CCW, negative logic																																																				
7	Phase A + Phase B (×1), negative logic																																																				
8	Phase A + Phase B (×2), negative logic																																																				
9	Phase A + Phase B (×4), negative logic																																																				
Error Counter Clear Signal From																																																					
0	Clears error counter when the signal is at H level.																																																				
1	Clears error counter at the rising edge of the signal.																																																				
2	Clears error counter when the signal is at L level.																																																				
3	Clears error counter at the falling edge of the signal.																																																				
Clear Operation																																																					
0	Clears error counter at the baseblock.																																																				
1	Does not clear error counter (Possible to clear error counter only with CLR signal).																																																				
2	Clears error counter when an alarm occurs.																																																				
Filter Selection																																																					
0	Reference input filter for line driver signals																																																				
1	Reference input filter for open collector signals																																																				
Pn201	PG Divider	16 to 16384 P/rev	1 P/rev	16384	16384	After restart	8.5.7																																														
Pn202	Electronic Gear Ratio (Numerator) *1	1 to 65535	—	—	4	After restart	8.6.2																																														
Pn203	Electronic Gear Ratio (Denominator) *1	1 to 65535	—	—	1	After restart	8.6.2																																														
Pn204	Position Reference Accel/Decel Time Constant *1	0.00 to 64.00 ms	0.01 ms	0	0	Immediately	8.6.4																																														
Pn205	Multiturn Limit Setting *2	0 to 65535 rev	rev	65535	65535	After restart	8.4.7																																														
Pn206	Reserved (Do not change)	—	—	16384	16384	—	—																																														

* 1. Used only for SGDJ-□□□P SERVOPACK for position control mode.

* 2. The multiturn limit must be changed only for special applications. Changing this limit inappropriately or unintentionally can be dangerous.

Parameter No.	Name	Setting Range	Units	Factory Setting		Setting Validation	Reference Section												
				□□□S	□□□P														
Pn207	Position Control Function Switches *	0000 to 1111	–	–	0000	After restart	8.6.4												
	<p>n. <input type="checkbox"/> <input type="checkbox"/> <input type="checkbox"/> <input type="checkbox"/></p> <p>4th digit 3rd digit 2nd digit 1st digit</p> <table border="1"> <tr> <th colspan="2">Position Reference Filter Selection (Refer to "8.6.4 Smoothing.")</th> </tr> <tr> <td>0</td> <td>Acceleration/deceleration filter</td> </tr> <tr> <td>1</td> <td>Average movement filter</td> </tr> <tr> <td colspan="2">Reserved (Do not change)</td> </tr> <tr> <td colspan="2">Reserved (Do not change)</td> </tr> <tr> <td colspan="2">Reserved (Do not change)</td> </tr> </table>							Position Reference Filter Selection (Refer to "8.6.4 Smoothing.")		0	Acceleration/deceleration filter	1	Average movement filter	Reserved (Do not change)		Reserved (Do not change)		Reserved (Do not change)	
	Position Reference Filter Selection (Refer to "8.6.4 Smoothing.")																		
	0	Acceleration/deceleration filter																	
	1	Average movement filter																	
Reserved (Do not change)																			
Reserved (Do not change)																			
Reserved (Do not change)																			
Pn208	Position Reference Movement Averaging Time *	0.00 to 64.00 ms	0.01 ms	–	0	After restart	8.6.4												
Pn300	Speed Reference Input Gain	1.50 to 30.00 V / rated speed	0.01V / rated speed	600	–	Immediately	8.5.1 8.7.4												
Pn301	Speed 1	0 to 10000 min ⁻¹	1 min ⁻¹	100	100	Immediately	8.8.1												
Pn302	Speed 2	0 to 10000 min ⁻¹	1 min ⁻¹	200	200	Immediately	8.8.1												
Pn303	Speed 3	0 to 10000 min ⁻¹	1 min ⁻¹	300	300	Immediately	8.8.1												
Pn304	JOG Speed	0 to 10000 min ⁻¹	1 min ⁻¹	500	500	Immediately	8.1.1												
Pn305	Soft Start Acceleration Time	0 to 10000 ms	1 ms	0	0	Immediately	8.5.4												
Pn306	Soft Start Deceleration Time	0 to 10000 ms	1 ms	0	0	Immediately	8.5.4												
Pn307	Speed Reference Filter Time Constant	0.00 to 655.35 ms	0.01 ms	40	–	Immediately	8.5.5												
Pn308	Speed Feedback Filter Time Constant	0.00 to 655.35 ms	0.01 ms	0	0	Immediately	9.4.6												
Pn400	Torque Reference Input Gain	1.0 to 10.0 V / rated torque	0.1 V / rated torque	30	–	Immediately	8.7.1 8.9.3 8.9.4 9.4.2												
Pn401	Torque Reference Filter Time Constant	0.00 to 655.35 ms	0.01 ms	100	100	Immediately	9.4.9												
Pn402	Forward Torque Limit	0 to 800%	1%	800	800	Immediately	8.9.1												
Pn403	Reverse Torque Limit	0 to 800%	1%	800	800	Immediately	8.9.1												
Pn404	Forward External Torque Limit	0 to 800%	1%	100	100	Immediately	8.9.2 8.9.4												
Pn405	Reverse External Torque Limit	0 to 800%	1%	100	100	Immediately	8.9.2 8.9.4												

* Used only for SGDJ-□□□P SERVOPACK for position control mode.

10.4.2 List of Parameters

Parameter No.	Name	Setting Range	Units	Factory Setting		Setting Validation	Reference Section									
				□□□S	□□□P											
Pn406	Emergency Stop Torque	0 to 800%	1%	800	800	Immediately	8.3.3									
Pn407	Speed Limit during Torque Control	0 to 10000 min ⁻¹	1 min ⁻¹	10000	–	Immediately	8.7.4									
Pn408	Torque Function Switches	0000 to 0101	–	0000	0000	Immediately	9.4.9									
								<table border="1"> <tr> <td>4th digit</td> <td>3rd digit</td> <td>2nd digit</td> <td>1st digit</td> </tr> <tr> <td>n. □</td> <td>□</td> <td>□</td> <td>□</td> </tr> </table>	4th digit	3rd digit	2nd digit	1st digit	n. □	□	□	□
								4th digit	3rd digit	2nd digit	1st digit					
								n. □	□	□	□					
								<table border="1"> <tr> <td colspan="2">Notch Filter Selection (Refer to "9.4.9 Torque Reference Filter.")</td> </tr> <tr> <td>0</td> <td>N/A</td> </tr> <tr> <td>1</td> <td>Uses a notch filter for torque reference.</td> </tr> </table>	Notch Filter Selection (Refer to "9.4.9 Torque Reference Filter.")		0	N/A	1	Uses a notch filter for torque reference.		
Notch Filter Selection (Refer to "9.4.9 Torque Reference Filter.")																
0	N/A															
1	Uses a notch filter for torque reference.															
Reserved (Do not change)																
Reserved (Do not change)																
Pn409	Notch Filter Frequency	50 to 2000 Hz	1 Hz	2000	2000	Immediately	9.4.9									
Pn500	Positioning Completed Width *	0 to 250 reference units	1 reference unit	–	7	Immediately	8.6.5									
Pn501	Zero Clamp Level	0 to 10000 min ⁻¹	1 min ⁻¹	10	–	Immediately	8.5.6									
Pn502	Rotation Detection Level	1 to 10000 min ⁻¹	1 min ⁻¹	20	–	Immediately	8.11.3									
Pn503	Speed Coincidence Signal Output Width	0 to 100 min ⁻¹	1 min ⁻¹	10	–	Immediately	8.5.8									
Pn504	NEAR Signal Width *	1 to 250 reference units	1 reference unit	–	7	Immediately	8.6.6									
Pn505	Overflow Level *	1 to 8388352	1 reference unit	–	1024	Immediately	9.3.3									
Pn506	Brake Reference - Servo OFF Delay Time	1 to 50 (10 to 500 ms)	10 ms	0	0	Immediately	8.3.4									
Pn507	Brake Reference Output Speed Level	0 to 10000 min ⁻¹	1 min ⁻¹	100	100	Immediately	8.3.4									
Pn508	Timing for Brake Reference Output during Motor Operation	10 to 100 (100 to 1000 ms)	10 ms	500	500	Immediately	8.3.4									
Pn509	Momentary Hold time	20 to 1000 ms	1 ms	20	20	Immediately	8.3.6									

* Used only for SGDJ-□□□P SERVOPACK for position control mode.

Parameter No.	Name	Setting Range	Units	Factory Setting		Setting Validation	Reference Section																																																																														
				□□□S	□□□P																																																																																
Pn50A	Input Signal Selections 1	–	–	2100	2100	After restart	–																																																																														
<div style="display: flex; align-items: flex-start;"> <div style="margin-right: 20px;"> <p>n. <input type="checkbox"/> <input type="checkbox"/> <input type="checkbox"/> <input type="checkbox"/></p> <p style="font-size: small; margin-left: 10px;">4th digit 3rd digit 2nd digit 1st digit</p> </div> <table border="1" style="width: 100%; border-collapse: collapse;"> <thead> <tr style="background-color: #333; color: white;"> <th colspan="2">Input Signal Allocation Mode (Refer to "7.3.2 Input Circuit Signal Allocation.")</th> </tr> </thead> <tbody> <tr> <td style="text-align: center;">0</td> <td>Uses the sequence input signal terminals with standard allocation.*</td> </tr> <tr> <td style="text-align: center;">1</td> <td>Changes the sequence input signal allocation for each signal.</td> </tr> </tbody> </table> <table border="1" style="width: 100%; border-collapse: collapse;"> <thead> <tr style="background-color: #333; color: white;"> <th colspan="2">/S-ON Signal Mapping Signal Polarity: Normal; Servo ON when ON (L-level) Signal Polarity: Reverse; Servo ON when OFF (H-level) (Refer to "8.3.1 Setting the Servo ON Signal.")</th> </tr> </thead> <tbody> <tr><td style="text-align: center;">0</td><td>ON when CN1-14 input signal is ON (L-level).</td></tr> <tr><td style="text-align: center;">1</td><td>ON when CN1-15 input signal is ON (L-level).</td></tr> <tr><td style="text-align: center;">2</td><td>ON when CN1-16 input signal is ON (L-level).</td></tr> <tr><td style="text-align: center;">3</td><td>ON when CN1-17 input signal is ON (L-level).</td></tr> <tr><td style="text-align: center;">4</td><td>ON when CN1-18 input signal is ON (L-level).</td></tr> <tr><td style="text-align: center;">5</td><td>ON when CN1-11 input signal is ON (L-level).</td></tr> <tr><td style="text-align: center;">6</td><td>ON when CN1-12 input signal is ON (L-level).</td></tr> <tr><td style="text-align: center;">7</td><td>Sets signal ON.</td></tr> <tr><td style="text-align: center;">8</td><td>Sets signal OFF.</td></tr> <tr><td style="text-align: center;">9</td><td>OFF when CN1-14 input signal is OFF (H-level).</td></tr> <tr><td style="text-align: center;">A</td><td>OFF when CN1-15 input signal is OFF (H-level).</td></tr> <tr><td style="text-align: center;">B</td><td>OFF when CN1-16 input signal is OFF (H-level).</td></tr> <tr><td style="text-align: center;">C</td><td>OFF when CN1-17 input signal is OFF (H-level).</td></tr> <tr><td style="text-align: center;">D</td><td>OFF when CN1-18 input signal is OFF (H-level).</td></tr> <tr><td style="text-align: center;">E</td><td>OFF when CN1-11 input signal is OFF (H-level).</td></tr> <tr><td style="text-align: center;">F</td><td>OFF when CN1-12 input signal is OFF (H-level).</td></tr> </tbody> </table> <table border="1" style="width: 100%; border-collapse: collapse;"> <thead> <tr style="background-color: #333; color: white;"> <th colspan="2">/P-CON Signal Mapping (P control when ON (L-level)) (Refer to "9.4.4 Using the Mode Switch (P/PI Switching).")</th> </tr> </thead> <tbody> <tr> <td style="text-align: center;">0 to F</td> <td>Same as /S-ON</td> </tr> </tbody> </table> <table border="1" style="width: 100%; border-collapse: collapse;"> <thead> <tr style="background-color: #333; color: white;"> <th colspan="2">P-OT Signal Mapping (Overtravel when OFF (H-level)) (Refer to "8.3.3 Setting the Overtravel Limit Function.")</th> </tr> </thead> <tbody> <tr><td style="text-align: center;">0</td><td>Forward run allowed when CN1-14 input signal is ON (L-level).</td></tr> <tr><td style="text-align: center;">1</td><td>Forward run allowed when CN1-15 input signal is ON (L-level).</td></tr> <tr><td style="text-align: center;">2</td><td>Forward run allowed when CN1-16 input signal is ON (L-level).</td></tr> <tr><td style="text-align: center;">3</td><td>Forward run allowed when CN1-17 input signal is ON (L-level).</td></tr> <tr><td style="text-align: center;">4</td><td>Forward run allowed when CN1-18 input signal is ON (L-level).</td></tr> <tr><td style="text-align: center;">5</td><td>Forward run allowed when CN1-11 input signal is ON (L-level).</td></tr> <tr><td style="text-align: center;">6</td><td>Forward run allowed when CN1-12 input signal is ON (L-level).</td></tr> <tr><td style="text-align: center;">7</td><td>Forward run prohibited.</td></tr> <tr><td style="text-align: center;">8</td><td>Forward run allowed.</td></tr> <tr><td style="text-align: center;">9</td><td>Forward run allowed when CN1-14 input signal is OFF (H-level).</td></tr> <tr><td style="text-align: center;">A</td><td>Forward run allowed when CN1-15 input signal is OFF (H-level).</td></tr> <tr><td style="text-align: center;">B</td><td>Forward run allowed when CN1-16 input signal is OFF (H-level).</td></tr> <tr><td style="text-align: center;">C</td><td>Forward run allowed when CN1-17 input signal is OFF (H-level).</td></tr> <tr><td style="text-align: center;">D</td><td>Forward run allowed when CN1-18 input signal is OFF (H-level).</td></tr> <tr><td style="text-align: center;">E</td><td>Forward run allowed when CN1-11 input signal is OFF (H-level).</td></tr> <tr><td style="text-align: center;">F</td><td>Forward run allowed when CN1-12 input signal is OFF (H-level).</td></tr> </tbody> </table> </div>								Input Signal Allocation Mode (Refer to "7.3.2 Input Circuit Signal Allocation.")		0	Uses the sequence input signal terminals with standard allocation.*	1	Changes the sequence input signal allocation for each signal.	/S-ON Signal Mapping Signal Polarity: Normal; Servo ON when ON (L-level) Signal Polarity: Reverse; Servo ON when OFF (H-level) (Refer to "8.3.1 Setting the Servo ON Signal.")		0	ON when CN1-14 input signal is ON (L-level).	1	ON when CN1-15 input signal is ON (L-level).	2	ON when CN1-16 input signal is ON (L-level).	3	ON when CN1-17 input signal is ON (L-level).	4	ON when CN1-18 input signal is ON (L-level).	5	ON when CN1-11 input signal is ON (L-level).	6	ON when CN1-12 input signal is ON (L-level).	7	Sets signal ON.	8	Sets signal OFF.	9	OFF when CN1-14 input signal is OFF (H-level).	A	OFF when CN1-15 input signal is OFF (H-level).	B	OFF when CN1-16 input signal is OFF (H-level).	C	OFF when CN1-17 input signal is OFF (H-level).	D	OFF when CN1-18 input signal is OFF (H-level).	E	OFF when CN1-11 input signal is OFF (H-level).	F	OFF when CN1-12 input signal is OFF (H-level).	/P-CON Signal Mapping (P control when ON (L-level)) (Refer to "9.4.4 Using the Mode Switch (P/PI Switching).")		0 to F	Same as /S-ON	P-OT Signal Mapping (Overtravel when OFF (H-level)) (Refer to "8.3.3 Setting the Overtravel Limit Function.")		0	Forward run allowed when CN1-14 input signal is ON (L-level).	1	Forward run allowed when CN1-15 input signal is ON (L-level).	2	Forward run allowed when CN1-16 input signal is ON (L-level).	3	Forward run allowed when CN1-17 input signal is ON (L-level).	4	Forward run allowed when CN1-18 input signal is ON (L-level).	5	Forward run allowed when CN1-11 input signal is ON (L-level).	6	Forward run allowed when CN1-12 input signal is ON (L-level).	7	Forward run prohibited.	8	Forward run allowed.	9	Forward run allowed when CN1-14 input signal is OFF (H-level).	A	Forward run allowed when CN1-15 input signal is OFF (H-level).	B	Forward run allowed when CN1-16 input signal is OFF (H-level).	C	Forward run allowed when CN1-17 input signal is OFF (H-level).	D	Forward run allowed when CN1-18 input signal is OFF (H-level).	E	Forward run allowed when CN1-11 input signal is OFF (H-level).	F	Forward run allowed when CN1-12 input signal is OFF (H-level).
Input Signal Allocation Mode (Refer to "7.3.2 Input Circuit Signal Allocation.")																																																																																					
0	Uses the sequence input signal terminals with standard allocation.*																																																																																				
1	Changes the sequence input signal allocation for each signal.																																																																																				
/S-ON Signal Mapping Signal Polarity: Normal; Servo ON when ON (L-level) Signal Polarity: Reverse; Servo ON when OFF (H-level) (Refer to "8.3.1 Setting the Servo ON Signal.")																																																																																					
0	ON when CN1-14 input signal is ON (L-level).																																																																																				
1	ON when CN1-15 input signal is ON (L-level).																																																																																				
2	ON when CN1-16 input signal is ON (L-level).																																																																																				
3	ON when CN1-17 input signal is ON (L-level).																																																																																				
4	ON when CN1-18 input signal is ON (L-level).																																																																																				
5	ON when CN1-11 input signal is ON (L-level).																																																																																				
6	ON when CN1-12 input signal is ON (L-level).																																																																																				
7	Sets signal ON.																																																																																				
8	Sets signal OFF.																																																																																				
9	OFF when CN1-14 input signal is OFF (H-level).																																																																																				
A	OFF when CN1-15 input signal is OFF (H-level).																																																																																				
B	OFF when CN1-16 input signal is OFF (H-level).																																																																																				
C	OFF when CN1-17 input signal is OFF (H-level).																																																																																				
D	OFF when CN1-18 input signal is OFF (H-level).																																																																																				
E	OFF when CN1-11 input signal is OFF (H-level).																																																																																				
F	OFF when CN1-12 input signal is OFF (H-level).																																																																																				
/P-CON Signal Mapping (P control when ON (L-level)) (Refer to "9.4.4 Using the Mode Switch (P/PI Switching).")																																																																																					
0 to F	Same as /S-ON																																																																																				
P-OT Signal Mapping (Overtravel when OFF (H-level)) (Refer to "8.3.3 Setting the Overtravel Limit Function.")																																																																																					
0	Forward run allowed when CN1-14 input signal is ON (L-level).																																																																																				
1	Forward run allowed when CN1-15 input signal is ON (L-level).																																																																																				
2	Forward run allowed when CN1-16 input signal is ON (L-level).																																																																																				
3	Forward run allowed when CN1-17 input signal is ON (L-level).																																																																																				
4	Forward run allowed when CN1-18 input signal is ON (L-level).																																																																																				
5	Forward run allowed when CN1-11 input signal is ON (L-level).																																																																																				
6	Forward run allowed when CN1-12 input signal is ON (L-level).																																																																																				
7	Forward run prohibited.																																																																																				
8	Forward run allowed.																																																																																				
9	Forward run allowed when CN1-14 input signal is OFF (H-level).																																																																																				
A	Forward run allowed when CN1-15 input signal is OFF (H-level).																																																																																				
B	Forward run allowed when CN1-16 input signal is OFF (H-level).																																																																																				
C	Forward run allowed when CN1-17 input signal is OFF (H-level).																																																																																				
D	Forward run allowed when CN1-18 input signal is OFF (H-level).																																																																																				
E	Forward run allowed when CN1-11 input signal is OFF (H-level).																																																																																				
F	Forward run allowed when CN1-12 input signal is OFF (H-level).																																																																																				

* When Pn50A.0 is set to 0 for the input signal standard allocation mode, the following modes are compatible: Pn50A.1 = 7, Pn50A.3 = 8, and Pn50B.0 = 8.

10.4.2 List of Parameters

Parameter No.	Name	Setting Range	Units	Factory Setting		Setting Validation	Reference Section																																														
				□□□S	□□□P																																																
Pn50B	Input Signal Selections 2	–	–	6543	6543	After restart	–																																														
<div style="display: flex; align-items: flex-start;"> <div style="margin-right: 10px;"> <p>n.</p> <div style="display: flex; justify-content: space-around; width: 100px;"> <div style="text-align: center;">4th digit □</div> <div style="text-align: center;">3rd digit □</div> <div style="text-align: center;">2nd digit □</div> <div style="text-align: center;">1st digit □</div> </div> </div> <table border="1" style="width: 100%; border-collapse: collapse;"> <thead> <tr style="background-color: #333; color: white;"> <th colspan="2">N-OT Signal Mapping (Overtravel when OFF (H-level)) (Refer to "8.3.3 Setting the Overtravel Limit Function.")</th> </tr> </thead> <tbody> <tr><td>0</td><td>Reverse run allowed when CN1-14 input signal is ON (L-level).</td></tr> <tr><td>1</td><td>Reverse run allowed when CN1-15 input signal is ON (L-level).</td></tr> <tr><td>2</td><td>Reverse run allowed when CN1-16 input signal is ON (L-level).</td></tr> <tr><td>3</td><td>Reverse run allowed when CN1-17 input signal is ON (L-level).</td></tr> <tr><td>4</td><td>Reverse run allowed when CN1-18 input signal is ON (L-level).</td></tr> <tr><td>5</td><td>Reverse run allowed when CN1-11 input signal is ON (L-level).</td></tr> <tr><td>6</td><td>Reverse run allowed when CN1-12 input signal is ON (L-level).</td></tr> <tr><td>7</td><td>Reverse run prohibited.</td></tr> <tr><td>8</td><td>Reverse run allowed.</td></tr> <tr><td>9</td><td>Reverse run allowed when CN1-14 input signal is OFF (H-level).</td></tr> <tr><td>A</td><td>Reverse run allowed when CN1-15 input signal is OFF (H-level).</td></tr> <tr><td>B</td><td>Reverse run allowed when CN1-16 input signal is OFF (H-level).</td></tr> <tr><td>C</td><td>Reverse run allowed when CN1-17 input signal is OFF (H-level).</td></tr> <tr><td>D</td><td>Reverse run allowed when CN1-18 input signal is OFF (H-level).</td></tr> <tr><td>E</td><td>Reverse run allowed when CN1-11 input signal is OFF (H-level).</td></tr> <tr><td>F</td><td>Reverse run allowed when CN1-12 input signal is OFF (H-level).</td></tr> </tbody> </table> <table border="1" style="width: 100%; border-collapse: collapse;"> <thead> <tr style="background-color: #333; color: white;"> <th colspan="2">/ALM-RST Signal Mapping (Alarm Reset when ON (L-level)) (Refer to "8.11.1 Servo Alarm Output (ALM) and Alarm Code Output (ALO1, ALO2, ALO3).")</th> </tr> </thead> <tbody> <tr><td>0 to F</td><td>Same as N-OT</td></tr> </tbody> </table> <table border="1" style="width: 100%; border-collapse: collapse;"> <thead> <tr style="background-color: #333; color: white;"> <th colspan="2">/P-CL Signal Mapping (Torque Limit when ON (L-level)) (Refer to "8.9.2 External Torque Limit (Output Torque Limiting by Input Signals).")</th> </tr> </thead> <tbody> <tr><td>0 to F</td><td>Same as /S-OT, the setting of 2nd digit of Pn50A</td></tr> </tbody> </table> <table border="1" style="width: 100%; border-collapse: collapse;"> <thead> <tr style="background-color: #333; color: white;"> <th colspan="2">/N-CL Signal Mapping (Torque Limit when ON (L-level)) (Refer to "8.9.2 External Torque Limit (Output Torque Limiting by Input Signals).")</th> </tr> </thead> <tbody> <tr><td>0 to F</td><td>Same as /S-OT, the setting of 2nd digit of Pn50A</td></tr> </tbody> </table> </div>								N-OT Signal Mapping (Overtravel when OFF (H-level)) (Refer to "8.3.3 Setting the Overtravel Limit Function.")		0	Reverse run allowed when CN1-14 input signal is ON (L-level).	1	Reverse run allowed when CN1-15 input signal is ON (L-level).	2	Reverse run allowed when CN1-16 input signal is ON (L-level).	3	Reverse run allowed when CN1-17 input signal is ON (L-level).	4	Reverse run allowed when CN1-18 input signal is ON (L-level).	5	Reverse run allowed when CN1-11 input signal is ON (L-level).	6	Reverse run allowed when CN1-12 input signal is ON (L-level).	7	Reverse run prohibited.	8	Reverse run allowed.	9	Reverse run allowed when CN1-14 input signal is OFF (H-level).	A	Reverse run allowed when CN1-15 input signal is OFF (H-level).	B	Reverse run allowed when CN1-16 input signal is OFF (H-level).	C	Reverse run allowed when CN1-17 input signal is OFF (H-level).	D	Reverse run allowed when CN1-18 input signal is OFF (H-level).	E	Reverse run allowed when CN1-11 input signal is OFF (H-level).	F	Reverse run allowed when CN1-12 input signal is OFF (H-level).	/ALM-RST Signal Mapping (Alarm Reset when ON (L-level)) (Refer to "8.11.1 Servo Alarm Output (ALM) and Alarm Code Output (ALO1, ALO2, ALO3).")		0 to F	Same as N-OT	/P-CL Signal Mapping (Torque Limit when ON (L-level)) (Refer to "8.9.2 External Torque Limit (Output Torque Limiting by Input Signals).")		0 to F	Same as /S-OT, the setting of 2nd digit of Pn50A	/N-CL Signal Mapping (Torque Limit when ON (L-level)) (Refer to "8.9.2 External Torque Limit (Output Torque Limiting by Input Signals).")		0 to F	Same as /S-OT, the setting of 2nd digit of Pn50A
N-OT Signal Mapping (Overtravel when OFF (H-level)) (Refer to "8.3.3 Setting the Overtravel Limit Function.")																																																					
0	Reverse run allowed when CN1-14 input signal is ON (L-level).																																																				
1	Reverse run allowed when CN1-15 input signal is ON (L-level).																																																				
2	Reverse run allowed when CN1-16 input signal is ON (L-level).																																																				
3	Reverse run allowed when CN1-17 input signal is ON (L-level).																																																				
4	Reverse run allowed when CN1-18 input signal is ON (L-level).																																																				
5	Reverse run allowed when CN1-11 input signal is ON (L-level).																																																				
6	Reverse run allowed when CN1-12 input signal is ON (L-level).																																																				
7	Reverse run prohibited.																																																				
8	Reverse run allowed.																																																				
9	Reverse run allowed when CN1-14 input signal is OFF (H-level).																																																				
A	Reverse run allowed when CN1-15 input signal is OFF (H-level).																																																				
B	Reverse run allowed when CN1-16 input signal is OFF (H-level).																																																				
C	Reverse run allowed when CN1-17 input signal is OFF (H-level).																																																				
D	Reverse run allowed when CN1-18 input signal is OFF (H-level).																																																				
E	Reverse run allowed when CN1-11 input signal is OFF (H-level).																																																				
F	Reverse run allowed when CN1-12 input signal is OFF (H-level).																																																				
/ALM-RST Signal Mapping (Alarm Reset when ON (L-level)) (Refer to "8.11.1 Servo Alarm Output (ALM) and Alarm Code Output (ALO1, ALO2, ALO3).")																																																					
0 to F	Same as N-OT																																																				
/P-CL Signal Mapping (Torque Limit when ON (L-level)) (Refer to "8.9.2 External Torque Limit (Output Torque Limiting by Input Signals).")																																																					
0 to F	Same as /S-OT, the setting of 2nd digit of Pn50A																																																				
/N-CL Signal Mapping (Torque Limit when ON (L-level)) (Refer to "8.9.2 External Torque Limit (Output Torque Limiting by Input Signals).")																																																					
0 to F	Same as /S-OT, the setting of 2nd digit of Pn50A																																																				



■ Input signal polarities

Signal	Effective Level	Voltage level	Contact
ON	Low (L) level	0 V	Close
OFF	High (H) level	24 V	Open

Parameter No.	Name	Setting Range	Units	Factory Setting		Setting Validation	Reference Section																																
				□□□S	□□□P																																		
Pn50C	Input Signal Selections 3	—	—	8888	8888	After restart	—																																
	<div style="display: flex; justify-content: space-around; align-items: flex-start;"> <div style="text-align: center;"> 4th digit <input type="text"/> </div> <div style="text-align: center;"> 3rd digit <input type="text"/> </div> <div style="text-align: center;"> 2nd digit <input type="text"/> </div> <div style="text-align: center;"> 1st digit <input type="text"/> </div> </div> <p>n. <input type="text"/></p>																																						
				<div style="background-color: #333; color: white; padding: 2px;">/SPD-D Signal Mapping</div> <div style="background-color: #333; color: white; padding: 2px;">(Refer to "8.8 Operating Using Speed Control with an Internally Set Speed.")</div> <table border="1" style="width: 100%; border-collapse: collapse;"> <tr><td style="width: 5%;">0</td><td>ON when CN1-14 input signal is ON (L-level).</td></tr> <tr><td>1</td><td>ON when CN1-15 input signal is ON (L-level).</td></tr> <tr><td>2</td><td>ON when CN1-16 input signal is ON (L-level).</td></tr> <tr><td>3</td><td>ON when CN1-17 input signal is ON (L-level).</td></tr> <tr><td>4</td><td>ON when CN1-18 input signal is ON (L-level).</td></tr> <tr><td>5</td><td>ON when CN1-11 input signal is ON (L-level).</td></tr> <tr><td>6</td><td>ON when CN1-12 input signal is ON (L-level).</td></tr> <tr><td>7</td><td>Sets signal ON.</td></tr> <tr><td>8</td><td>Sets signal OFF.</td></tr> <tr><td>9</td><td>ON when CN1-14 input signal is OFF (H-level).</td></tr> <tr><td>A</td><td>ON when CN1-15 input signal is OFF (H-level).</td></tr> <tr><td>B</td><td>ON when CN1-16 input signal is OFF (H-level).</td></tr> <tr><td>C</td><td>ON when CN1-17 input signal is OFF (H-level).</td></tr> <tr><td>D</td><td>ON when CN1-18 input signal is OFF (H-level).</td></tr> <tr><td>E</td><td>ON when CN1-11 input signal is OFF (H-level).</td></tr> <tr><td>F</td><td>ON when CN1-12 input signal is OFF (H-level).</td></tr> </table>				0	ON when CN1-14 input signal is ON (L-level).	1	ON when CN1-15 input signal is ON (L-level).	2	ON when CN1-16 input signal is ON (L-level).	3	ON when CN1-17 input signal is ON (L-level).	4	ON when CN1-18 input signal is ON (L-level).	5	ON when CN1-11 input signal is ON (L-level).	6	ON when CN1-12 input signal is ON (L-level).	7	Sets signal ON.	8	Sets signal OFF.	9	ON when CN1-14 input signal is OFF (H-level).	A	ON when CN1-15 input signal is OFF (H-level).	B	ON when CN1-16 input signal is OFF (H-level).	C	ON when CN1-17 input signal is OFF (H-level).	D	ON when CN1-18 input signal is OFF (H-level).	E	ON when CN1-11 input signal is OFF (H-level).	F	ON when CN1-12 input signal is OFF (H-level).
0	ON when CN1-14 input signal is ON (L-level).																																						
1	ON when CN1-15 input signal is ON (L-level).																																						
2	ON when CN1-16 input signal is ON (L-level).																																						
3	ON when CN1-17 input signal is ON (L-level).																																						
4	ON when CN1-18 input signal is ON (L-level).																																						
5	ON when CN1-11 input signal is ON (L-level).																																						
6	ON when CN1-12 input signal is ON (L-level).																																						
7	Sets signal ON.																																						
8	Sets signal OFF.																																						
9	ON when CN1-14 input signal is OFF (H-level).																																						
A	ON when CN1-15 input signal is OFF (H-level).																																						
B	ON when CN1-16 input signal is OFF (H-level).																																						
C	ON when CN1-17 input signal is OFF (H-level).																																						
D	ON when CN1-18 input signal is OFF (H-level).																																						
E	ON when CN1-11 input signal is OFF (H-level).																																						
F	ON when CN1-12 input signal is OFF (H-level).																																						
				<div style="background-color: #333; color: white; padding: 2px;">/SPD-A Signal Mapping</div> <div style="background-color: #333; color: white; padding: 2px;">(Refer to "8.8 Operating Using Speed Control with an Internally Set Speed.")</div> <table border="1" style="width: 100%; border-collapse: collapse;"> <tr><td style="width: 5%;">0 to F</td><td>Same as /SPD-D</td></tr> </table>				0 to F	Same as /SPD-D																														
0 to F	Same as /SPD-D																																						
				<div style="background-color: #333; color: white; padding: 2px;">/SPD-B Signal Mapping</div> <div style="background-color: #333; color: white; padding: 2px;">(Refer to "8.8 Operating Using Speed Control with an Internally Set Speed.")</div> <table border="1" style="width: 100%; border-collapse: collapse;"> <tr><td style="width: 5%;">0 to F</td><td>Same as /SPD-D</td></tr> </table>				0 to F	Same as /SPD-D																														
0 to F	Same as /SPD-D																																						
				<div style="background-color: #333; color: white; padding: 2px;">/C-SEL Signal Mapping (Control mode change when ON (L-level))</div> <div style="background-color: #333; color: white; padding: 2px;">(Refer to "8.10.2 Switching the Control Mode.")</div> <table border="1" style="width: 100%; border-collapse: collapse;"> <tr><td style="width: 5%;">0 to F</td><td>Same as /SPD-D</td></tr> </table>				0 to F	Same as /SPD-D																														
0 to F	Same as /SPD-D																																						

10.4.2 List of Parameters

Parameter No.	Name	Setting Range	Units	Factory Setting		Setting Validation	Reference Section																																																																																																																																										
				□□□S	□□□P																																																																																																																																												
Pn50D	Input Signal Selections 4	—	—	8888	8888	After restart	—																																																																																																																																										
<table border="1" style="width: 100%; border-collapse: collapse;"> <tr> <td style="width: 5%; text-align: center;">n.</td> <td style="width: 10%; text-align: center;">4th digit</td> <td style="width: 10%; text-align: center;">3rd digit</td> <td style="width: 10%; text-align: center;">2nd digit</td> <td style="width: 10%; text-align: center;">1st digit</td> <td style="width: 55%;"></td> </tr> <tr> <td></td> <td style="text-align: center;">□</td> <td style="text-align: center;">□</td> <td style="text-align: center;">□</td> <td style="text-align: center;">□</td> <td style="background-color: #cccccc;">/ZCLAMP Signal Mapping (Zero clamp when ON (L-level)) (Refer to "8.5.6 Using the Zero Clamp Function.")</td> </tr> <tr> <td></td> <td></td> <td></td> <td></td> <td></td> <td>0 ON when CN1-14 input signal is ON (L-level).</td> </tr> <tr> <td></td> <td></td> <td></td> <td></td> <td></td> <td>1 ON when CN1-15 input signal is ON (L-level).</td> </tr> <tr> <td></td> <td></td> <td></td> <td></td> <td></td> <td>2 ON when CN1-16 input signal is ON (L-level).</td> </tr> <tr> <td></td> <td></td> <td></td> <td></td> <td></td> <td>3 ON when CN1-17 input signal is ON (L-level).</td> </tr> <tr> <td></td> <td></td> <td></td> <td></td> <td></td> <td>4 ON when CN1-18 input signal is ON (L-level).</td> </tr> <tr> <td></td> <td></td> <td></td> <td></td> <td></td> <td>5 ON when CN1-11 input signal is ON (L-level).</td> </tr> <tr> <td></td> <td></td> <td></td> <td></td> <td></td> <td>6 ON when CN1-12 input signal is ON (L-level).</td> </tr> <tr> <td></td> <td></td> <td></td> <td></td> <td></td> <td>7 Sets signal ON.</td> </tr> <tr> <td></td> <td></td> <td></td> <td></td> <td></td> <td>8 Sets signal OFF.</td> </tr> <tr> <td></td> <td></td> <td></td> <td></td> <td></td> <td>9 ON when CN1-14 input signal is OFF (H-level).</td> </tr> <tr> <td></td> <td></td> <td></td> <td></td> <td></td> <td>A ON when CN1-15 input signal is OFF (H-level).</td> </tr> <tr> <td></td> <td></td> <td></td> <td></td> <td></td> <td>B ON when CN1-16 input signal is OFF (H-level).</td> </tr> <tr> <td></td> <td></td> <td></td> <td></td> <td></td> <td>C ON when CN1-17 input signal is OFF (H-level).</td> </tr> <tr> <td></td> <td></td> <td></td> <td></td> <td></td> <td>D ON when CN1-18 input signal is OFF (H-level).</td> </tr> <tr> <td></td> <td></td> <td></td> <td></td> <td></td> <td>E ON when CN1-11 input signal is OFF (H-level).</td> </tr> <tr> <td></td> <td></td> <td></td> <td></td> <td></td> <td>F ON when CN1-12 input signal is OFF (H-level).</td> </tr> <tr> <td></td> <td></td> <td></td> <td></td> <td></td> <td style="background-color: #cccccc;">/INHIBIT Signal Mapping (Reference pulse inhibit when ON (L-level)) (Refer to "8.6.7 Reference Pulse Inhibit Function (INHIBIT).")</td> </tr> <tr> <td></td> <td></td> <td></td> <td></td> <td></td> <td>0 to F Same as /ZCLAMP</td> </tr> <tr> <td></td> <td></td> <td></td> <td></td> <td></td> <td style="background-color: #cccccc;">/G-SEL Signal Mapping (Gain change when ON (L-level)) (Refer to "9.4.8 Switching Gain Settings.")</td> </tr> <tr> <td></td> <td></td> <td></td> <td></td> <td></td> <td>0 to F Same as /ZCLAMP</td> </tr> <tr> <td></td> <td></td> <td></td> <td></td> <td></td> <td style="background-color: #cccccc;">Reserved (Do not change)</td> </tr> </table>								n.	4th digit	3rd digit	2nd digit	1st digit			□	□	□	□	/ZCLAMP Signal Mapping (Zero clamp when ON (L-level)) (Refer to "8.5.6 Using the Zero Clamp Function.")						0 ON when CN1-14 input signal is ON (L-level).						1 ON when CN1-15 input signal is ON (L-level).						2 ON when CN1-16 input signal is ON (L-level).						3 ON when CN1-17 input signal is ON (L-level).						4 ON when CN1-18 input signal is ON (L-level).						5 ON when CN1-11 input signal is ON (L-level).						6 ON when CN1-12 input signal is ON (L-level).						7 Sets signal ON.						8 Sets signal OFF.						9 ON when CN1-14 input signal is OFF (H-level).						A ON when CN1-15 input signal is OFF (H-level).						B ON when CN1-16 input signal is OFF (H-level).						C ON when CN1-17 input signal is OFF (H-level).						D ON when CN1-18 input signal is OFF (H-level).						E ON when CN1-11 input signal is OFF (H-level).						F ON when CN1-12 input signal is OFF (H-level).						/INHIBIT Signal Mapping (Reference pulse inhibit when ON (L-level)) (Refer to "8.6.7 Reference Pulse Inhibit Function (INHIBIT).")						0 to F Same as /ZCLAMP						/G-SEL Signal Mapping (Gain change when ON (L-level)) (Refer to "9.4.8 Switching Gain Settings.")						0 to F Same as /ZCLAMP						Reserved (Do not change)
n.	4th digit	3rd digit	2nd digit	1st digit																																																																																																																																													
	□	□	□	□	/ZCLAMP Signal Mapping (Zero clamp when ON (L-level)) (Refer to "8.5.6 Using the Zero Clamp Function.")																																																																																																																																												
					0 ON when CN1-14 input signal is ON (L-level).																																																																																																																																												
					1 ON when CN1-15 input signal is ON (L-level).																																																																																																																																												
					2 ON when CN1-16 input signal is ON (L-level).																																																																																																																																												
					3 ON when CN1-17 input signal is ON (L-level).																																																																																																																																												
					4 ON when CN1-18 input signal is ON (L-level).																																																																																																																																												
					5 ON when CN1-11 input signal is ON (L-level).																																																																																																																																												
					6 ON when CN1-12 input signal is ON (L-level).																																																																																																																																												
					7 Sets signal ON.																																																																																																																																												
					8 Sets signal OFF.																																																																																																																																												
					9 ON when CN1-14 input signal is OFF (H-level).																																																																																																																																												
					A ON when CN1-15 input signal is OFF (H-level).																																																																																																																																												
					B ON when CN1-16 input signal is OFF (H-level).																																																																																																																																												
					C ON when CN1-17 input signal is OFF (H-level).																																																																																																																																												
					D ON when CN1-18 input signal is OFF (H-level).																																																																																																																																												
					E ON when CN1-11 input signal is OFF (H-level).																																																																																																																																												
					F ON when CN1-12 input signal is OFF (H-level).																																																																																																																																												
					/INHIBIT Signal Mapping (Reference pulse inhibit when ON (L-level)) (Refer to "8.6.7 Reference Pulse Inhibit Function (INHIBIT).")																																																																																																																																												
					0 to F Same as /ZCLAMP																																																																																																																																												
					/G-SEL Signal Mapping (Gain change when ON (L-level)) (Refer to "9.4.8 Switching Gain Settings.")																																																																																																																																												
					0 to F Same as /ZCLAMP																																																																																																																																												
					Reserved (Do not change)																																																																																																																																												

Parameter No.	Name	Setting Range	Units	Factory Setting		Setting Validation	Reference Section																					
				□□□S	□□□P																							
Pn50E	Output Signal Selections 1	—	—	3211	3211	After restart	—																					
	<div style="display: flex; align-items: flex-start;"> <div style="margin-right: 10px;"> n. <div style="display: flex; justify-content: space-around; width: 100px;"> 4th digit3rd digit2nd digit1st digit </div> <div style="display: flex; justify-content: space-around; width: 100px;"> <input type="checkbox"/><input type="checkbox"/><input type="checkbox"/><input type="checkbox"/> </div> </div> <table border="1" style="width: 100%;"> <tr> <td colspan="2">Positioning Completion Signal Mapping (/COIN) (Refer to "8.6.5 Positioning Completed Output Signal.")</td> </tr> <tr> <td>0</td> <td>Disabled (the above signal is not used.)</td> </tr> <tr> <td>1</td> <td>Outputs the signal from CN1-8, 10 output terminal.</td> </tr> <tr> <td>2</td> <td>Outputs the signal from CN1-9, 10 output terminal.</td> </tr> <tr> <td>3</td> <td>Outputs the signal from CN1-7, 10 output terminal.</td> </tr> <tr> <td colspan="2">Speed Coincidence Detection Signal Mapping (/V-CMP) (Refer to "8.5.8 Speed Coincidence Output.")</td> </tr> <tr> <td>0 to 3</td> <td>Same as /COIN</td> </tr> <tr> <td colspan="2">Rotation Detection Signal Mapping (/TGON) (Refer to "8.11.3 Running Output Signal (/TGON).")</td> </tr> <tr> <td>0 to 3</td> <td>Same as /COIN</td> </tr> <tr> <td colspan="2">Servo Ready Signal Mapping (/S-RDY) (Refer to "8.11.4 Servo Ready (/S-RDY) Output.")</td> </tr> <tr> <td>0 to 3</td> <td>Same as /COIN</td> </tr> </table> </div>	Positioning Completion Signal Mapping (/COIN) (Refer to "8.6.5 Positioning Completed Output Signal.")		0	Disabled (the above signal is not used.)	1	Outputs the signal from CN1-8, 10 output terminal.	2	Outputs the signal from CN1-9, 10 output terminal.	3	Outputs the signal from CN1-7, 10 output terminal.	Speed Coincidence Detection Signal Mapping (/V-CMP) (Refer to "8.5.8 Speed Coincidence Output.")		0 to 3	Same as /COIN	Rotation Detection Signal Mapping (/TGON) (Refer to "8.11.3 Running Output Signal (/TGON).")		0 to 3	Same as /COIN	Servo Ready Signal Mapping (/S-RDY) (Refer to "8.11.4 Servo Ready (/S-RDY) Output.")		0 to 3	Same as /COIN					
Positioning Completion Signal Mapping (/COIN) (Refer to "8.6.5 Positioning Completed Output Signal.")																												
0	Disabled (the above signal is not used.)																											
1	Outputs the signal from CN1-8, 10 output terminal.																											
2	Outputs the signal from CN1-9, 10 output terminal.																											
3	Outputs the signal from CN1-7, 10 output terminal.																											
Speed Coincidence Detection Signal Mapping (/V-CMP) (Refer to "8.5.8 Speed Coincidence Output.")																												
0 to 3	Same as /COIN																											
Rotation Detection Signal Mapping (/TGON) (Refer to "8.11.3 Running Output Signal (/TGON).")																												
0 to 3	Same as /COIN																											
Servo Ready Signal Mapping (/S-RDY) (Refer to "8.11.4 Servo Ready (/S-RDY) Output.")																												
0 to 3	Same as /COIN																											
Pn50F	Output Signal Selections 2	—	—	0000	0000	After restart	—																					
	<div style="display: flex; align-items: flex-start;"> <div style="margin-right: 10px;"> n. <div style="display: flex; justify-content: space-around; width: 100px;"> 4th digit3rd digit2nd digit1st digit </div> <div style="display: flex; justify-content: space-around; width: 100px;"> <input type="checkbox"/><input type="checkbox"/><input type="checkbox"/><input type="checkbox"/> </div> </div> <table border="1" style="width: 100%;"> <tr> <td colspan="2">Torque Limit Detection Signal Mapping (/CLT) (Refer to "8.9.5 Checking Output Torque Limiting during Operation.")</td> </tr> <tr> <td>0</td> <td>Disabled (the above signal is not used.)</td> </tr> <tr> <td>1</td> <td>Outputs the signal from CN1-8, 10 output terminal.</td> </tr> <tr> <td>2</td> <td>Outputs the signal from CN1-9, 10 output terminal.</td> </tr> <tr> <td>3</td> <td>Outputs the signal from CN1-7, 10 output terminal.</td> </tr> <tr> <td colspan="2">Speed Limit Detection Signal Mapping (/VLT) (Refer to "8.7.4 Limiting Servomotor Speed during Torque Control.")</td> </tr> <tr> <td>0 to 3</td> <td>Same as /CLT</td> </tr> <tr> <td colspan="2">Brake Interlock Signal Mapping (/BK) (Refer to "8.3.4 Setting for Holding Brakes.")</td> </tr> <tr> <td>0 to 3</td> <td>Same as /CLT</td> </tr> <tr> <td colspan="2">Warning Signal Mapping (/WARN) (Refer to "8.11.2 Warning Output (/WARN).")</td> </tr> <tr> <td>0 to 3</td> <td>Same as /CLT</td> </tr> </table> </div>	Torque Limit Detection Signal Mapping (/CLT) (Refer to "8.9.5 Checking Output Torque Limiting during Operation.")		0	Disabled (the above signal is not used.)	1	Outputs the signal from CN1-8, 10 output terminal.	2	Outputs the signal from CN1-9, 10 output terminal.	3	Outputs the signal from CN1-7, 10 output terminal.	Speed Limit Detection Signal Mapping (/VLT) (Refer to "8.7.4 Limiting Servomotor Speed during Torque Control.")		0 to 3	Same as /CLT	Brake Interlock Signal Mapping (/BK) (Refer to "8.3.4 Setting for Holding Brakes.")		0 to 3	Same as /CLT	Warning Signal Mapping (/WARN) (Refer to "8.11.2 Warning Output (/WARN).")		0 to 3	Same as /CLT					
Torque Limit Detection Signal Mapping (/CLT) (Refer to "8.9.5 Checking Output Torque Limiting during Operation.")																												
0	Disabled (the above signal is not used.)																											
1	Outputs the signal from CN1-8, 10 output terminal.																											
2	Outputs the signal from CN1-9, 10 output terminal.																											
3	Outputs the signal from CN1-7, 10 output terminal.																											
Speed Limit Detection Signal Mapping (/VLT) (Refer to "8.7.4 Limiting Servomotor Speed during Torque Control.")																												
0 to 3	Same as /CLT																											
Brake Interlock Signal Mapping (/BK) (Refer to "8.3.4 Setting for Holding Brakes.")																												
0 to 3	Same as /CLT																											
Warning Signal Mapping (/WARN) (Refer to "8.11.2 Warning Output (/WARN).")																												
0 to 3	Same as /CLT																											

10.4.2 List of Parameters

Parameter No.	Name	Setting Range	Units	Factory Setting		Setting Validation	Reference Section																												
				□□□S	□□□P																														
Pn510	Output Signal Selections 3	0000 to 0333	–	0000	0000	After restart	–																												
	<div style="display: flex; align-items: flex-start;"> <div style="margin-right: 20px;"> <p>n.</p> <table style="border-collapse: collapse;"> <tr> <td style="text-align: center; padding: 5px;">4th digit</td> <td style="text-align: center; padding: 5px;">3rd digit</td> <td style="text-align: center; padding: 5px;">2nd digit</td> <td style="text-align: center; padding: 5px;">1st digit</td> </tr> <tr> <td style="text-align: center; padding: 5px;">□</td> <td style="text-align: center; padding: 5px;">□</td> <td style="text-align: center; padding: 5px;">□</td> <td style="text-align: center; padding: 5px;">□</td> </tr> </table> </div> <div> <table border="1" style="width: 100%; border-collapse: collapse;"> <thead> <tr style="background-color: #333; color: white;"> <th colspan="2">Near Signal Mapping (/NEAR) (Refer to "8.6.6 Positioning Near Signal.")</th> </tr> </thead> <tbody> <tr> <td style="text-align: center;">0</td> <td>Disabled (the above signal is not used.)</td> </tr> <tr> <td style="text-align: center;">1</td> <td>Outputs the signal from CN1-25 or -26 terminals.</td> </tr> <tr> <td style="text-align: center;">2</td> <td>Outputs the signal from CN1-27 or -28 terminals.</td> </tr> <tr> <td style="text-align: center;">3</td> <td>Outputs the signal from CN1-29 or -30 terminals.</td> </tr> <tr style="background-color: #333; color: white;"> <td colspan="2">Reserved (Do not change)</td> </tr> <tr style="background-color: #333; color: white;"> <td colspan="2">Reserved (Do not change)</td> </tr> <tr style="background-color: #333; color: white;"> <td colspan="2">Reserved (Do not change)</td> </tr> </tbody> </table> </div> </div>							4th digit	3rd digit	2nd digit	1st digit	□	□	□	□	Near Signal Mapping (/NEAR) (Refer to "8.6.6 Positioning Near Signal.")		0	Disabled (the above signal is not used.)	1	Outputs the signal from CN1-25 or -26 terminals.	2	Outputs the signal from CN1-27 or -28 terminals.	3	Outputs the signal from CN1-29 or -30 terminals.	Reserved (Do not change)		Reserved (Do not change)		Reserved (Do not change)					
4th digit	3rd digit	2nd digit	1st digit																																
□	□	□	□																																
Near Signal Mapping (/NEAR) (Refer to "8.6.6 Positioning Near Signal.")																																			
0	Disabled (the above signal is not used.)																																		
1	Outputs the signal from CN1-25 or -26 terminals.																																		
2	Outputs the signal from CN1-27 or -28 terminals.																																		
3	Outputs the signal from CN1-29 or -30 terminals.																																		
Reserved (Do not change)																																			
Reserved (Do not change)																																			
Reserved (Do not change)																																			
Pn511	Reserved (Do not change)	–	–	8888	8888	Immediately	–																												
Pn512	Output Signal Reversal Settings	–	–	0000	0000	After restart	7.3.3																												
	<div style="display: flex; align-items: flex-start;"> <div style="margin-right: 20px;"> <p>n.</p> <table style="border-collapse: collapse;"> <tr> <td style="text-align: center; padding: 5px;">4th digit</td> <td style="text-align: center; padding: 5px;">3rd digit</td> <td style="text-align: center; padding: 5px;">2nd digit</td> <td style="text-align: center; padding: 5px;">1st digit</td> </tr> <tr> <td style="text-align: center; padding: 5px;">□</td> <td style="text-align: center; padding: 5px;">□</td> <td style="text-align: center; padding: 5px;">□</td> <td style="text-align: center; padding: 5px;">□</td> </tr> </table> </div> <div> <table border="1" style="width: 100%; border-collapse: collapse;"> <thead> <tr style="background-color: #333; color: white;"> <th colspan="2">Output Signal Reversal for CN1-8 or -10 Terminals</th> </tr> </thead> <tbody> <tr> <td style="text-align: center;">0</td> <td>Output signal is not reversed.</td> </tr> <tr> <td style="text-align: center;">1</td> <td>Output signal is reversed.</td> </tr> <tr style="background-color: #333; color: white;"> <th colspan="2">Output Signal Reversal for CN1-9 or -10 Terminals</th> </tr> <tr> <td style="text-align: center;">0</td> <td>Output signal is not reversed.</td> </tr> <tr> <td style="text-align: center;">1</td> <td>Output signal is reversed.</td> </tr> <tr style="background-color: #333; color: white;"> <th colspan="2">Output Signal Reversal for CN1-7 or -10 Terminals</th> </tr> <tr> <td style="text-align: center;">0</td> <td>Output signal is not reversed.</td> </tr> <tr> <td style="text-align: center;">1</td> <td>Output signal is reversed.</td> </tr> <tr style="background-color: #333; color: white;"> <td colspan="2">Reserved (Do not change)</td> </tr> </tbody> </table> </div> </div>							4th digit	3rd digit	2nd digit	1st digit	□	□	□	□	Output Signal Reversal for CN1-8 or -10 Terminals		0	Output signal is not reversed.	1	Output signal is reversed.	Output Signal Reversal for CN1-9 or -10 Terminals		0	Output signal is not reversed.	1	Output signal is reversed.	Output Signal Reversal for CN1-7 or -10 Terminals		0	Output signal is not reversed.	1	Output signal is reversed.	Reserved (Do not change)	
4th digit	3rd digit	2nd digit	1st digit																																
□	□	□	□																																
Output Signal Reversal for CN1-8 or -10 Terminals																																			
0	Output signal is not reversed.																																		
1	Output signal is reversed.																																		
Output Signal Reversal for CN1-9 or -10 Terminals																																			
0	Output signal is not reversed.																																		
1	Output signal is reversed.																																		
Output Signal Reversal for CN1-7 or -10 Terminals																																			
0	Output signal is not reversed.																																		
1	Output signal is reversed.																																		
Reserved (Do not change)																																			
Pn600	Regenerative Resistor Capacity *1	Depends on SERVO-PACK Capacity *2	10 W	0	0	Immediately	–																												
Pn601	Reserved (Do not change)	Depends on SERVO-PACK Capacity *2	–	0	0	Immediately	–																												

* 1. Normally set to "0." When using an external regenerative resistor, set the allowable power loss (W) of the regenerative resistor.

* 2. The upper limit is the maximum output capacity (W) of the SERVOPACK.

10.4.3 Monitor Modes

The following list shows monitor modes available.

Parameter No.	Content of Display	Unit
Un000	Actual motor speed	min ⁻¹
Un001	Input speed reference (Enabled only when speed control mode.)	min ⁻¹
Un002	Internal torque reference (Value for rated torque)	%
Un003	Rotation angle 1 (Number of pulses from the zero point:16-bit decimal code)	pulse
Un004	Rotation angle 2 (Angle from the zero point (electrical angle))	deg
Un005	Input signal monitor	–
Un006	Output signal monitor	–
Un007	Input reference pulse speed (displayed only in position control mode)	min ⁻¹
Un008	Error counter value (amount of position error) (displayed only in position control mode)	reference unit
Un009	Accumulated load rate (Value for the rated torque as 100%: Displays effective torque in 10 s cycle.)	%
Un00A	Reserved	–
Un00B	Power consumed by DB resistance (Value for the processable power when dynamic brake is applied as 100%: Displays DB power consumption in 10 s cycle.)	%
Un00C	Input reference pulse counter (hexadecimal code) (displayed only in position control mode)	–
Un00D	Feedback pulse counter (hexadecimal code)	–

INDEX

A

absolute encoder battery	2-13
absolute encoder reception sequence	8-31
absolute encoder setup	8-30
absolute encoders	8-27
AC/DC power supply and power supply input capacitor	2-14
adjusting offset	8-39
alarm code output	8-76, 10-2
alarm display table	10-2
alarm reset	8-76, 10-2
alarm traceback data clear (Fn006)	7-11
alarm traceback data display (Fn000)	7-8
alignment	3-12
allocating input signals	7-23
allocating output signals	7-25
ALM	6-13, 8-76
ALM-RST	6-12, 7-3
ALO	6-13
ambient/storage temperature	4-3
analog monitor	4-4, 9-26
analog monitor cable	2-13
angular transmission error accuracy	3-17
attaching the ferrite core	6-22
automatic offset-adjustment of motor current detection signal (Fn00E)	7-12
autotuning functions	9-3

B

ball screw	8-51
BAT	6-12
belt and pulley	8-51
bias setting	4-3
BK	6-13
block diagram for position control	8-55

C

cables for analog monitor	5-18
cables for connecting personal computers	5-16
CE marking	1-7
checking products	1-2
circuit time constant	4-3
clear signal form selection	8-48
CLR	6-12
CLT	6-13
CN1	
terminal layout	6-10
CN2	
terminal layout	6-6
COIN	6-13
connecting the digital operator	7-2
connection cable for digital operator	2-13
connection cable for personal computer	2-13
connection to host controller	10-20
connector terminal block converter unit	5-19
connectors and cables for encoder signals	5-11

control method	4-3
control mode selection	8-17, 8-74
CSA standards	1-7

D

DATA/ENTER key	7-3
digital operator	2-13, 5-17
key names and functions	7-3
status display	7-5
disc table	8-51
DOWN key	7-3
DSPL/SET key	7-3
dynamic brake	4-4

E

electronic gear	4-4
electronic gear ratio equation	8-51
encoder cable	2-9, 5-10
encoder connector (CN2) terminal layout	6-6
encoder signal converter unit	5-22
encoder signal output	8-44
extending encoder cables	6-24
external torque limit	8-69

F

feed forward compensation	4-3
feed-forward reference	9-14
forward rotation prohibited	8-20
frequency characteristics	4-3

G

ground noise	3-17
grounding	6-18

H

handling batteries	8-29
handling oil and water	3-13
hot start	4-10

I

I/O signal (CN1) names and functions	6-12
I/O signal cables	2-12, 5-13
I/O signal connections	6-7
impact acceleration	3-14, 3-16
impact occurrences	3-14, 3-16
impact resistance	3-16
input circuit signal allocation	7-21
input impedance	4-3
input signal monitor display	7-27
installation conditions of EMC directives	6-21
instantaneous power loss settings	8-26
interface for reference input circuits	6-14
analog input circuit	6-14
position reference input circuit	6-14
internal torque limit	8-68

L

LEFT key	7-3
limiting torque	8-68
list of parameter	10-30
list of utility function modes	7-7
load moment of inertia	4-11

load regulation	4-3
lost motion	3-17

M

machine rigidity setting	9-8
main circuit wiring examples	6-4
manual adjustment of the torque reference offset	8-62
manual gain adjustment of analog monitor output (Fn00D)	9-30
manual offset-adjustment of the motor current detection signal (Fn00F)	7-13
manual tuning	9-11
manual zero adjustment of analog monitor output (Fn00C)	9-29
mating concentricity of the flange	3-14, 3-15
max. allowable input motor speed	3-17
mechanical characteristics of SGMAJ servomotors	3-15
mechanical characteristics of SGMMJ servomotors	3-14
mode switch (P/PI switching)	9-17
molded-case circuit breaker (MCCB)	2-13
molded-case circuit breaker and fuse capacity	2-13
monitor display	
feedback pulse counter	7-29
reference pulse counter	7-29
monitor mode	7-26
motor models display (Fn011)	7-15
multiturn limit setting	8-35

N

names and functions of main circuit terminals	6-2
N-CL	6-12
NEAR	6-13
noise data	3-17
noise filter	5-21
noise interference	6-17
north american safety standards	1-7
N-OT	6-12
notch filter	9-24

O

online autotuning	9-5
machine rigidity setting	9-8
saving the results	9-10
operating using position control	8-47
operating using speed control with an internally set speed	8-65
operating using speed control with analog reference	8-37
operating using torque control	8-60
operation in monitor mode	7-28
output circuit interface	6-15
line driver output circuit	6-15
open-collector output circuit	6-16
photocoupler output circuit	6-16
output circuit signal allocation	7-24
output signal monitor display	7-28
overshooting	9-17
overtravel stop	4-4

P

PAO	6-13
PAO serial data specifications	8-32
parameter setting mode	7-17
parameter settings initialization (Fn005)	7-10
parameters	7-18, 7-20

example of changing function selection	7-20
password setting (protects parameters from being changed) (Fn010)	7-14
PBO	6-13
P-CL	6-12
PCO	6-13
P-CON	6-12
peripheral device selection	2-12, 2-15
noise filters, surge suppressors, magnetic conductors, and brake power supply	2-15
perpendicularity between the flange face and output shaft	3-14, 3-15
PG divider	8-45
position control by host controller	8-16
position loop gain	9-12
positioning completed output signal	8-57
positioning completed width setting	4-3
positioning near signal	8-58
positioning time reduction functions	9-3
P-OT	6-12
proportional control operation (proportional operation reference) protection	9-16, 4-4
PSO	6-13
PULS	6-12
pulse dividing ratio setting	8-45

R

rated input motor speed	3-17
rated torque	3-17
reference pulse	
form	4-3
frequency	4-3
type	4-3
reference pulse inhibit function (INHIBIT)	8-59
reference unit	8-49
reference voltage	4-3
replacing batteries	8-29
replacing oil seal	10-18
RESET key	7-3
reverse rotation prohibited	8-20
RIGHT key	7-3
running output signal	8-77
run-out at the end of the shaft	3-14, 3-15

S

selecting a position reference filter	8-56
selecting an absolute encoder	8-29
selecting cables	2-8
selecting the speed loop control method (PI Control or IP Control)	9-13
selecting the stopping method after servo OFF	8-25
SEN	6-12
SEN signal connection	8-28
sequence I/O signal monitor display	7-27
sequence input	4-4
sequence input circuit interface	6-15
sequence output	4-4
servo alarm output	8-76, 10-2
servo gain	
adjustment methods	9-2
explanation	9-11
servo ready output	8-78
servo system configurations	1-6
servomotor connection connector kit	2-11

servomotor inspection - - - - -	10-18	software version display (Fn012) - - - - -	7-16
servomotor main circuit cable		S-ON - - - - -	6-12
specifications and dimensional drawings - - - - -	5-2	specifications and dimensional drawings of servomotor main circuit cable - - - - -	5-2
servomotor main circuit cables and connectors - - - - -	2-10	speed coincidence output - - - - -	8-46
servomotor model designations		speed control range - - - - -	4-3
model SGMAJ - - - - -	2-4	speed feedback compensation - - - - -	9-21
model SGMMJ - - - - -	2-2	speed limit during torque control - - - - -	8-64
servomotors		speed loop gain - - - - -	9-13
inspection and maintenance - - - - -	10-18	speed loop integral time constant - - - - -	9-13
mechanical specifications - - - - -	3-12	speed reference input - - - - -	4-3
model designations - - - - -	2-2	speed regulation - - - - -	4-4
nameplate - - - - -	1-2	S-RDY - - - - -	6-13, 8-78
overhanging loads - - - - -	4-12	standard replacement period - - - - -	10-19
precautions on servomotor installation - - - - -	3-12	starting time - - - - -	4-11
product part names - - - - -	1-4, 1-5	stopping time - - - - -	4-11
wire size - - - - -	5-4	surge suppressor - - - - -	5-21
SERVOPACK inspection - - - - -	10-18	surge suppressor for magnetic contactor - - - - -	5-21
SERVOPACK main circuit wire size and connectors - - - - -	5-4	SVON key - - - - -	7-3
SERVOPACK's parts replacement schedule - - - - -	10-19	switching gain settings - - - - -	9-23
SERVOPACKs		switching the servomotor rotation direction - - - - -	8-19
installation - - - - -	4-5		
internal block diagrams - - - - -	4-7	T	
load moment of inertia - - - - -	4-10	temperature regulation - - - - -	4-3
model designations - - - - -	2-6	terms - - - - -	3-17
nameplate - - - - -	1-3	TGON - - - - -	6-13, 8-77
operating conditions - - - - -	4-5	through shaft section - - - - -	3-13
overload characteristics - - - - -	4-10	torque control tolerance - - - - -	4-3
power losses - - - - -	4-9	torque limiting using an analog voltage reference - - - - -	8-71
power supply capacities - - - - -	4-9	torque reference filter - - - - -	9-24
product part names - - - - -	1-5	torsion rigidity - - - - -	3-17
ratings and specifications - - - - -	4-2	T-REF - - - - -	6-12
setting a reference pulse form - - - - -	8-47	trial operation - - - - -	8-4
setting for holding brakes - - - - -	8-22	trial operation for servomotor without load - - - - -	8-6
setting the electronic gear - - - - -	8-49	troubleshooting - - - - -	10-2
setting the overtravel limit function - - - - -	8-20	alarm - - - - -	10-5
setting the servo ON signal - - - - -	8-18	malfunction without alarm display - - - - -	10-13
setting the speed bias - - - - -	9-20	U	
SGDJ SERVOPACKs and applicable servomotors - - - - -	2-7	UL standards - - - - -	1-7
SGMAJ servomotor connectors for standard environments - - - - -	5-6	undershooting - - - - -	9-17
SGMAJ servomotors (3000 min-1) - - - - -	3-5, 3-8, 3-10	UP key - - - - -	7-3
derating rate for servomotor with oil seal - - - - -	3-6	using more than one SERVOPACK - - - - -	6-23
dimensional drawings - - - - -	3-25	V	
holding brake electrical specifications - - - - -	3-7	variable resistor for speed and torque setting - - - - -	5-21
holding brake moment of inertia - - - - -	3-6	V-CMP - - - - -	6-13
torque-motor speed characteristics - - - - -	3-6	vibration class - - - - -	3-16
with low-backlash gears - - - - -	3-10	vibration reduction functions - - - - -	9-4
with standard backlash gears - - - - -	3-8	vibration resistance - - - - -	3-14, 3-16
without gears - - - - -	3-5	vibration/shock resistance - - - - -	4-3
SGMMJ servomotor connectors for standard environments - - - - -	5-5	VLT - - - - -	6-13
SGMMJ servomotors (3000 min-1) - - - - -	3-2, 3-4	voltage regulation - - - - -	4-3
dimensional drawings - - - - -	3-19	V-REF - - - - -	6-12
holding brake electrical specifications - - - - -	3-3	W	
holding brake moment of inertia - - - - -	3-3	WARN - - - - -	6-13, 8-77
torque-motor speed characteristics - - - - -	3-3	warning code output - - - - -	10-4
with standard backlash gears - - - - -	3-4	warning display - - - - -	10-4
without gears - - - - -	3-2	warning display and troubleshooting - - - - -	10-12
shield box - - - - -	6-22	warning output - - - - -	8-77
SIGN - - - - -	6-12		
soft start - - - - -	8-42		
soft start time setting - - - - -	4-3		

wiring	
absolute encoders	6-6
incremental encoders	6-5
wiring encoders	6-5
wiring example	6-18
wiring for noise control	6-18
wiring main circuit power supply connector	6-3
wiring precautions	6-17

Z

zero clamp function	8-42
zero-point search mode (Fn003)	7-9

Revision History

The revision dates and numbers of the revised manuals are given on the bottom of the back cover.

MANUAL NO. SIE-S800-38B

© Printed in Japan November 2002 00-06 ◇

└─ Date of printing

└─ Date of original publication

└─ Revision number

Date of Printing	Rev. No.	Section	Revised Content
June 2000	–		First edition
November 2002	◇	All chapters	Completely revised
March 2004	◇	2.1.1	Addition: SGMMJ servomotor model designations
		2.4	Addition: SGDJ SERVOPACKs and applicable servomotors
		2.6	Revision: Type of the I/O signal cables connector kit JZSP-CKI9 to JZSP-VAI09
		3.1	Addition: Ratings and specifications for SGMMJ servomotors (3000min ⁻¹) (without gears and with standard backlash gears)
		3.3.2	Addition: Mechanical characteristics of SGMMJ servomotors
		3.5	Addition: Dimensional drawings of SGMMJ servomotors (3000min ⁻¹) (standard and with/without brakes, with gears and with/without brakes)
		5.2.2	Addition: SGMMJ servomotor connectors for standard environments
		5.2.3 (3) (4)	Revision: Type of the SERVOPACK power supply input connector kit JZSP-CFG9-2 to JZSP-CIG9-2 JZSP-CFG9-3 to JZSP-CIG9-3
		5.5.2	Revision: Type of the I/O signal cables connector kit JZSP-CKI9 to JZSP-VAI09
August 2004	◇	9.5.2	Addition: Manual zero adjustment and gain adjustment of analog monitor output
		4.6.2	Revision: Mounting hole diagram

DC Power Input Σ -II Series SGM□J/SGDJ USER'S MANUAL

IRUMA BUSINESS CENTER

480, Kamifujisawa, Iruma, Saitama 358-8555, Japan
Phone 81-4-2962-5696 Fax 81-4-2962-6138

YASKAWA ELECTRIC AMERICA, INC.

2121 Norman Drive South, Waukegan, IL 60085, U.S.A.
Phone 1-847-887-7000 Fax 1-847-887-7370

MOTOMAN INC. HEADQUARTERS

805 Liberty Lane West Carrollton, OH 45449, U.S.A.
Phone 1-937-847-6200 Fax 1-937-847-6277

YASKAWA ELÉTRICO DO BRASIL COMÉRCIO LTD.A.

Avenida Fagundes Filho, 620 Bairro Saude-Sao Paulo-SP, Brazil CEP: 04304-000
Phone 55-11-5071-2552 Fax 55-11-5581-8795

YASKAWA ELECTRIC EUROPE GmbH

Am Kronberger Hang 2, 65824 Schwalbach, Germany
Phone 49-6196-569-300 Fax 49-6196-569-312

Motoman Robotics Europe AB

Box 504 S38525 Torsås, Sweden
Phone 46-486-48800 Fax 46-486-41410

Motoman Robotec GmbH

Kammerfeldstraße 1, 85391 Allershausen, Germany
Phone 49-8166-90-100 Fax 49-8166-90-103

YASKAWA ELECTRIC UK LTD.

1 Hunt Hill Orchardton Woods Cumbernauld, G68 9LF, United Kingdom
Phone 44-1236-735000 Fax 44-1236-458182

YASKAWA ELECTRIC KOREA CORPORATION

Kipa Bldg #1201, 35-4 Youido-dong, Yeongdungpo-Ku, Seoul 150-010, Korea
Phone 82-2-784-7844 Fax 82-2-784-8495

YASKAWA ELECTRIC (SINGAPORE) PTE. LTD.

151 Lorong Chuan, #04-01, New Tech Park Singapore 556741, Singapore
Phone 65-6282-3003 Fax 65-6289-3003

YASKAWA ELECTRIC (SHANGHAI) CO., LTD.

No.18 Xizang Zhong Road, Room 1805, Harbour Ring Plaza Shanghai 20000, China
Phone 86-21-5385-2200 Fax 86-21-5385-3299

YATEC ENGINEERING CORPORATION

4F., No.49 Wu Kong 6 Rd, Wu-Ku Industrial Park, Taipei, Taiwan
Phone 886-2-2298-3676 Fax 886-2-2298-3677

YASKAWA ELECTRIC (HK) COMPANY LIMITED

Rm. 2909-10, Hong Kong Plaza, 186-191 Connaught Road West, Hong Kong
Phone 852-2803-2385 Fax 852-2547-5773

BEIJING OFFICE

Room No. 301 Office Building of Beijing International Club, 21
Jianguomenwai Avenue, Beijing 100020, China
Phone 86-10-6532-1850 Fax 86-10-6532-1851

TAIPEI OFFICE

9F, 16, Nanking E. Rd., Sec. 3, Taipei, Taiwan
Phone 886-2-2502-5003 Fax 886-2-2505-1280

SHANGHAI YASKAWA-TONGJI M & E CO., LTD.

27 Hui He Road Shanghai China 200437
Phone 86-21-6553-6060 Fax 86-21-5588-1190

BEIJING YASKAWA BEIKE AUTOMATION ENGINEERING CO., LTD.

30 Xue Yuan Road, Haidian, Beijing P.R. China Post Code: 100083
Phone 86-10-6233-2782 Fax 86-10-6232-1536

SHOUGANG MOTOMAN ROBOT CO., LTD.

7, Yongchang-North Street, Beijing Economic Technological Investment & Development Area,
Beijing 100076, P.R. China
Phone 86-10-6788-0551 Fax 86-10-6788-2878



YASKAWA ELECTRIC CORPORATION

YASKAWA

In the event that the end user of this product is to be the military and said product is to be employed in any weapons systems or the manufacture thereof, the export will fall under the relevant regulations as stipulated in the Foreign Exchange and Foreign Trade Regulations. Therefore, be sure to follow all procedures and submit all relevant documentation according to any and all rules, regulations and laws that may apply.

Specifications are subject to change without notice for ongoing product modifications and improvements.

© 2000-2004 YASKAWA ELECTRIC CORPORATION. All rights reserved.

MANUAL NO. SIE-S800-38C

Printed in Japan August 2004 00-6 ④
04-1⑤ 99-23029