

Machine Controller MP3000 Series

MP3300

Product Manual

CPU Module model: JAPMC-CP3301-1-E, -CP3301-2-E, -CP3302-1-E, -CP3302-2-E
Base Unit model: JEPMC-BU3301-E, -BU3302-E, -BU3303-E, -BU3304-E

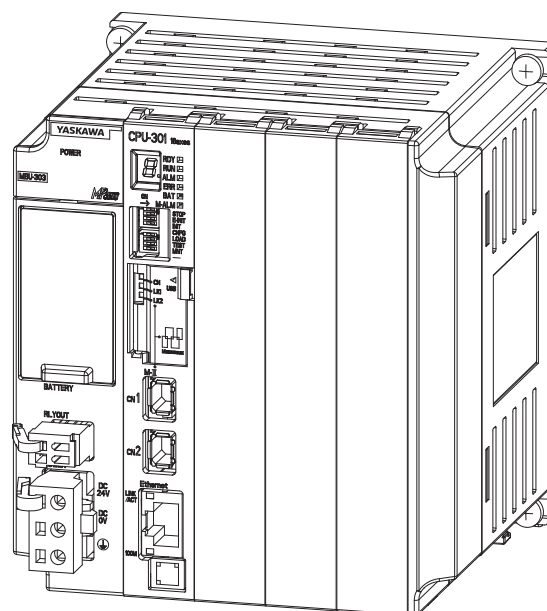

Introduction	1
Appearances and Parts	2
CPU Module Functionality	3
Specifications	4
External Dimensions	5

Copyright © 2014 YASKAWA ELECTRIC CORPORATION

All rights reserved. No part of this publication may be reproduced, stored in a retrieval system, or transmitted, in any form, or by any means, mechanical, electronic, photocopying, recording, or otherwise, without the prior written permission of Yaskawa. No patent liability is assumed with respect to the use of the information contained herein. Moreover, because Yaskawa is constantly striving to improve its high-quality products, the information contained in this manual is subject to change without notice. Every precaution has been taken in the preparation of this manual. Nevertheless, Yaskawa assumes no responsibility for errors or omissions. Neither is any liability assumed for damages resulting from the use of the information contained in this publication.

About this Manual

This manual describes the specifications and system configuration of MP3300 Machine Controllers and the functionality of the CPU Modules.

Read this manual carefully to ensure the correct usage of the Machine Controller and apply the Machine Controller to control your manufacturing system.

Keep this manual in a safe place so that it can be referred to whenever necessary.

Using this Manual

◆ Basic Terms

Unless otherwise specified, the following definitions are used:

Basic Terms	Meaning
MP2000	A Machine Controller in the MP2000 Series
MP3000	A Machine Controller in the MP3000 Series
MPE720	The Engineering Tool or a personal computer running the Engineering Tool
PLC	A Programmable Logic Controller
MP3300	A generic name for the CPU Module and Base Unit.
Machine Controller	An MP3300 Machine Controller in the MP3000 Series
Motion Control Function Modules	The Function Modules in the Motion Modules and the Function Modules in the SVC, SVC32, SVR, or SVR32 built into the CPU Modules.
Communications Function Modules	The Function Modules in the Communications Modules and the Function Modules in the 218IFD built into the CPU Module.

◆ MPE720 Engineering Tool Version Number

In this manual, the operation of MPE720 is described using screen captures of MPE720 version 7.

◆ Indication of Reverse Signals

In this manual, the names of reverse signals (ones that are valid when low) are written with a forward slash (/) before the signal name, as shown in the following example:

Notation Examples

- $\overline{\text{S-ON}}$ = /S-ON
- $\overline{\text{P-CON}}$ = /P-CON

◆ The Meaning of “Torque” in This Manual

Although the term “torque” is commonly used when describing rotary Servomotors and “force” is used when describing linear Servomotors, this manual uses “torque” when describing either one (excluding parameter names).

◆ Copyrights

- MECHATROLINK is a trademark of the MECHATROLINK Members Association.
- DeviceNet is a registered trademark of the ODVA (Open DeviceNet Vendors Association).
- PROFIBUS is a trademark of the PROFIBUS User Organization.
- Ethernet is a registered trademark of the Xerox Corporation.
- Other product names and company names are the trademarks or registered trademarks of the respective company. “TM” and the ® mark do not appear with product or company names in this manual.

◆ Visual Aids

The following aids are used to indicate certain types of information for easier reference.



Important

Indicates precautions or restrictions that must be observed.

Indicates alarm displays and other precautions that will not result in machine damage.

Example

Indicates operating or setting examples.

Information

Indicates supplemental information to deepen understanding or useful information.



Term

Indicates definitions of difficult terms or terms that have not been previously explained in this manual.

Related Manuals

The following table lists the related manuals. Refer to these manuals as required.

Be aware of all product specifications and restrictions to product application before you attempt to use any product.

Category	Manual Name	Manual Number	Contents
Basic functionality	Machine Controller MP3000 Series Machine Controller System Setup Manual	SIEP C880725 00	Describes the functions of the MP3000-series Machine Controllers and the procedures that are required to use the Machine Controller, from installation and connections to settings, programming, trial operation, and debugging.
	Machine Controller MP2000 Series Machine Controller System Setup Manual	SIEP C880732 14	Describes the functions of the MP2000-series Machine Controllers and the procedures that are required to use the Machine Controller, from installation and connections to settings, programming, trial operation, and debugging.
	Machine Controller MP3000 Series Machine Controller System Troubleshooting Manual	SIEP C880725 01	Describes troubleshooting an MP3000-series Machine Controller System.
	Machine Controller MP3000 Series MP3100 Product Manual	SIEP C880725 24	Describes the specifications and system configuration of an MP3000-series MP3100 Machine Controller and the functions of the CPU.
	Machine Controller MP3000 Series MP3200 Product Manual	SIEP C880725 10	Describes the specifications and system configuration of an MP3000-series MP3200 Machine Controller and the functions of the CPU Unit.
	Machine Controller MP2200 User's Manual	SIEP C880700 14	Describes the functions, specifications, and application methods of the MP2200 Machine Controller.
	Machine Controller MP2000 Series MPU-01 Multi-CPU Module User's Manual	SIEP C880781 05	Describes the functions, specifications, operating methods, maintenance, inspections, and troubleshooting of the MP2000-series MPU-01 Multi-CPU Module.

Continued on next page.

Continued from previous page.

Category	Manual Name	Manual Number	Contents
Communications functionality	Machine Controller MP3000 Series Communications User's Manual	SIEP C880725 12	Describes the specifications, system configuration, and communications connection methods for the Ethernet communications that are used with an MP3000-series Machine Controller.
	Machine Controller MP2000 Series Communication Module User's Manual	SIEP C880700 04	Provides information on the Communications Modules that can be connected to an MP2000-series Machine Controller and describes the communications methods.
	Machine Controller MP2000 Series 262IF-01 FL-net Communication Module User's Manual	SIEP C880700 36	Describes the specifications and communications methods for the FL-net Communications Module that can be connected to an MP2000-series Machine Controller.
	Machine Controller MP2000 Series 263IF-01 EtherNet/IP Communication Module User's Manual	SIEP C880700 39	Describes the specifications and communications methods for the EtherNet/IP Communications Module that can be connected to an MP2000-series Machine Controller.
	Machine Controller MP2000 Series 265IF-01 CompoNet Module User's Manual	SIEP C880700 44	Describes the specifications and communications methods for the CompoNet Communications Module that can be connected to an MP2000-series Machine Controller.
Motion control functionality	Machine Controller MP3000 Series Motion Control User's Manual	SIEP C880725 11	Describes the specifications, system configuration, and operating methods for the SVC32/SVR32 Motion Function Modules that are used in an MP3000-series Machine Controller.
	Machine Controller MP2000 Series Pulse Output Motion Module PO-01 User's Manual	SIEP C880700 28	Describes the functions, specifications, and operating methods of the MP2000-series PO-01 Motion Module.
	Machine Controller MP2000 Series SVA-01 Motion Module User's Manual	SIEP C880700 32	Describes the functions, specifications, and operating methods of the MP2000-series SVA-01 Motion Module.
	Machine Controller MP2000 Series Built-in SVB/SVB-01 Motion Module User's Manual	SIEP C880700 33	Describes the functions, specifications, and operating methods of the MP2000-series Motion Module (built-in Function Modules: SVB, SVB-01, and SVR).
	Machine Controller MP2000 Series SVC-01 Motion Module User's Manual	SIEP C880700 41	Describes the functions, specifications, and operating methods of the MP2000-series SVC-01 Motion Module.
Programming	Machine Controller MP3000 Series Ladder Programming Manual	SIEP C880725 13	Describes the ladder programming specifications and instructions of MP3000-series Machine Controller.
	Machine Controller MP3000 Series Motion Programming Manual	SIEP C880725 14	Describes the motion programming and sequence programming specifications and instructions of MP3000-series Machine Controller.

Continued on next page.

Continued from previous page.

Category	Manual Name	Manual Number	Contents
Engineering Tools	Machine Controller MP2000/MP3000 Series MPLoader Ver. 4 User's Manual	SIEP C880761 01	Describes how to install and operate the MPLoader.
	Machine Controller MP2000/MP3000 Series MPLoad Maker Version 4 User's Manual	SIEP C880761 02	Describes how to install and operate the MPLoad Maker.
	Machine Controller MP2000/MP3000 Series Engineering Tool MPE720 Version 7 User's Manual	SIEP C880761 03	Describes how to operate MPE720 version 7.
I/O Modules	Machine Controller MP2000 Series Analog Input/Analog Output Module AI-01/AO-01 User's Manual	SIEP C880700 26	Describes the functions, specifications, and operating methods of the AI-01 and AO-01 I/O Modules for MP2000-series Machine Controllers.
	Machine Controller MP2000 Series Counter Module CNTR-01 User's Manual	SIEP C880700 27	Describes the functions, specifications, and operating methods of the CNTR-01 Counter Module for MP2000-series Machine Controllers.
	Machine Controller MP2000 Series I/O Module User's Manual	SIEP C880700 34	Describes the functions, specifications, and operating methods of the LIO-01, LIO-02, LIO-04, LIO-05, LIO-06, and DO-01 I/O Modules for MP2000-series Machine Controllers.
MECHATROLINK I/O	MECHATROLINK-III Compatible I/O Module User's Manual	SIEP C880781 04	Describes the functions, specifications, operating methods, and MECHATROLINK-III communications for the Remote I/O Modules for MP2000/MP3000-series Machine Controllers.
	Machine Controller MP900/MP2000 Series Distributed I/O Module User's Manual MECHATROLINK System	SIE-C887-5.1	Describes MECHATROLINK distributed I/O for MP900/MP2000-series Machine Controllers.

Safety Precautions

◆ Safety Information

To prevent personal injury and equipment damage in advance, the following signal words are used to indicate safety precautions in this document. The signal words are used to classify the hazards and the degree of damage or injury that may occur if a product is used incorrectly. Information marked as shown below is important for safety. Always read this information and heed the precautions that are provided.



DANGER

- Indicates precautions that, if not heeded, are likely to result in loss of life, serious injury, or fire.



WARNING

- Indicates precautions that, if not heeded, could result in loss of life, serious injury, or fire.



CAUTION

- Indicates precautions that, if not heeded, could result in relatively serious or minor injury, or in fire.

NOTICE

- Indicates precautions that, if not heeded, could result in property damage.

◆ Safety Precautions That Must Always Be Observed

■ General Precautions



WARNING

- The installation must be suitable and it must be performed only by an experienced technician. There is a risk of electrical shock or injury.
- Before connecting the machine and starting operation, make sure that an emergency stop procedure has been provided and is working correctly. There is a risk of injury.
- Do not approach the machine after a momentary interruption to the power supply. When power is restored, the Machine Controller and the device connected to it may start operation suddenly. Provide safety measures in advance to ensure human safety when operation restarts. There is a risk of injury.
- Do not touch anything inside the Machine Controller. There is a risk of electrical shock.
- Do not remove the front cover, cables, connector, or options while power is being supplied. There is a risk of electrical shock, malfunction, or damage.
- Do not damage, pull on, apply excessive force to, place heavy objects on, or pinch the cables. There is a risk of electrical shock, operational failure of the Machine Controller, or burning.
- Do not attempt to modify the Machine Controller in any way. There is a risk of injury or device damage.

■ Storage and Transportation Precautions



CAUTION

- Do not store the Machine Controller in any of the following locations.
 - Locations that are subject to direct sunlight
 - Locations that are subject to ambient temperatures that exceed the storage conditions
 - Locations that are subject to ambient humidity that exceeds the storage conditions
 - Locations that are subject to rapid temperature changes and condensation
 - Locations that are subject to corrosive or inflammable gas
 - Locations that are subject to excessive dust, dirt, salt, or metallic powder
 - Locations that are subject to water, oil, or chemicals
 - Locations that are subject to vibration or shockThere is a risk of fire, electrical shock, or device damage.
- Hold onto the main body of the Machine Controller when transporting it. Holding the cables or connectors may damage them or result in injury.
- Do not overload the Machine Controller during transportation. (Follow all instructions.) There is a risk of injury or an accident.
- Never subject the Machine Controller to an atmosphere containing halogen (fluorine, chlorine, bromine, or iodine) during transportation. There is a risk of malfunction or damage.
- If disinfectants or insecticides must be used to treat packing materials such as wooden frames, pallets, or plywood, the packing materials must be treated before the product is packaged, and methods other than fumigation must be used.

Example: Heat treatment, where materials are kiln-dried to a core temperature of 56°C for 30 minutes or more.

If the electronic products, which include stand-alone products and products installed in machines, are packed with fumigated wooden materials, the electrical components may be greatly damaged by the gases or fumes resulting from the fumigation process. In particular, disinfectants containing halogen, which includes chlorine, fluorine, bromine, or iodine can contribute to the erosion of the capacitors.

■ Installation Precautions



CAUTION

- **Do not install the Machine Controller in any of the following locations.**
 - Locations that are subject to direct sunlight
 - Locations that are subject to ambient temperatures that exceed the operating conditions
 - Locations that are subject to ambient humidity that exceeds the operating conditions
 - Locations that are subject to rapid temperature changes and condensation
 - Locations that are subject to corrosive or inflammable gas
 - Locations that are subject to excessive dust, dirt, salt, or metallic powder
 - Locations that are subject to water, oil, or chemicals
 - Locations that are subject to vibration or shockThere is a risk of fire, electrical shock, or device damage.
- **Never install the Machine Controller in an atmosphere containing halogen (fluorine, chlorine, bromine, or iodine).**
There is a risk of malfunction or damage.
- **Do not step on the Machine Controller or place heavy objects on the Machine Controller.**
There is a risk of injury or an accident.
- **Do not block the air exhaust ports on the Machine Controller. Do not allow foreign objects to enter the Machine Controller.**
There is a risk of internal element deterioration, malfunction, or fire.
- **Always mount the Machine Controller in the specified orientation.**
There is a risk of malfunction.
- **Leave the specified amount of space between the Machine Controller, and the interior surface of the control panel and other devices.**
There is a risk of fire or malfunction.
- **Do not subject the Machine Controller to strong shock.**
There is a risk of malfunction.
- **Suitable Battery installation must be performed and it must be performed only by an experienced technician.**
There is a risk of electrical shock, injury, or device damage.
- **Do not touch the electrodes of the Battery.**
Static electricity may damage the Battery.

■ Wiring Precautions

CAUTION

- **Check the wiring to be sure it has been performed correctly.**
There is a risk of motor run-away, injury, or accidents.
- **Always use a power supply of the specified voltage.**
There is a risk of fire or accident.
- **In places with poor power supply conditions, ensure that the input power is supplied within the specified voltage range.**
There is a risk of device damage.
- **Install breakers and other safety measures to provide protection against shorts in external wiring.**
There is a risk of fire.
- **Provide sufficient shielding when using the Machine Controller in the following locations.**
 - Locations that are subject to noise, such as from static electricity
 - Locations that are subject to strong electromagnetic or magnetic fields
 - Locations that are subject to radiation
 - Locations that are near power linesThere is a risk of device damage.
- **Configure the circuits to turn ON the power supply to the CPU Module before the 24-V I/O power supply. Refer to the following manual for details on circuits.**
 MP3000 Series MP3300 CPU Module Instructions Manual (Manual No.: TOBP C880725 23)
If the power supply to the CPU Module is turned ON after the external power supply, e.g., the 24-V I/O power supply, the outputs from the CPU Module may momentarily turn ON when the power supply to the CPU Module turns ON. This can result in unexpected operation that may cause injury or device damage.
- **Provide emergency stop circuits, interlock circuits, limit circuits, and any other required safety measures in control circuits outside of the Machine Controller.**
There is a risk of injury or device damage.
- **If you use MECHATROLINK I/O Modules, use the establishment of MECHATROLINK communications as an interlock output condition.**
There is a risk of device damage.
- **Connect the Battery with the correct polarity.**
There is a risk of battery damage or explosion.
- **Select the I/O signal wires for external wiring to connect the Machine Controller to external devices based on the following criteria:**
 - Mechanical strength
 - Noise interference
 - Wiring distance
 - Signal voltage
- **Separate the I/O signal cables for control circuits from the power cables both inside and outside the control panel to reduce the influence of noise from the power cables.**
If the I/O signal lines and power lines are not separated properly, malfunction may occur.

Example of Separated Cables

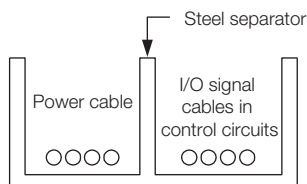

■ Operation Precautions

CAUTION

- Follow the procedures and instructions in the user's manuals for the relevant products to perform normal operation and trial operation.
Operating mistakes while the Servomotor and machine are connected may damage the machine or even cause accidents resulting in injury or death.
- Implement interlock signals and other safety circuits external to the Machine Controller to ensure safety in the overall system even if the following conditions occur.
 - Machine Controller failure or errors caused by external factors
 - Shutdown of operation due to Machine Controller detection of an error in self-diagnosis and the subsequent turning OFF or holding of output signals
 - Holding of the ON or OFF status of outputs from the Machine Controller due to fusing or burning of output relays or damage to output transistors
 - Voltage drops from overloads or short-circuits in the 24-V output from the Machine Controller and the subsequent inability to output signals
 - Unexpected outputs due to errors in the power supply, I/O, or memory that cannot be detected by the Machine Controller through self-diagnosis.There is a risk of injury, device damage, or burning.

■ Maintenance and Inspection Precautions

CAUTION

- Do not attempt to disassemble or repair the Machine Controller.
There is a risk of electrical shock, injury, or device damage.
- Do not change any wiring while power is being supplied.
There is a risk of electrical shock, injury, or device damage.
- Suitable Battery replacement must be performed and it must be performed only by an experienced technician.
There is a risk of electrical shock, injury, or device damage.
- Do not forget to perform the following tasks when you replace the CPU Module:
 - Back up all programs and parameters from the CPU Module that is being replaced.
 - Transfer all saved programs and parameters to the new CPU Module.If you operate the CPU Module without transferring this data, unexpected operation may occur.
There is a risk of injury or device damage.
- Do not touch the heat sink on the CPU Module while the power supply is turned ON or for a sufficient period of time after the power supply is turned OFF.
The heat sink may be very hot, and there is a risk of burn injury.

■ Disposal Precautions

- Dispose of the Machine Controller as general industrial waste.
- Observe all local laws and ordinances when you dispose of used Batteries.

■ General Precautions

- The products shown in the illustrations in this manual are sometimes shown without covers or protective guards. Always replace the cover or protective guard as specified first, and then operate the products in accordance with the manual.
- The illustrations that are presented in this manual are typical examples and may not match the product you received.
- If the manual must be ordered due to loss or damage, inform your nearest Yaskawa representative or one of the offices listed on the back of this manual.

Warranty

◆ Details of Warranty

■ Warranty Period

The warranty period for a product that was purchased (hereinafter called “delivered product”) is one year from the time of delivery to the location specified by the customer or 18 months from the time of shipment from the Yaskawa factory, whichever is sooner.

■ Warranty Scope

Yaskawa shall replace or repair a defective product free of charge if a defect attributable to Yaskawa occurs during the warranty period above. This warranty does not cover defects caused by the delivered product reaching the end of its service life and replacement of parts that require replacement or that have a limited service life.

This warranty does not cover failures that result from any of the following causes.

- Improper handling, abuse, or use in unsuitable conditions or in environments not described in product catalogs or manuals, or in any separately agreed-upon specifications
- Causes not attributable to the delivered product itself
- Modifications or repairs not performed by Yaskawa
- Abuse of the delivered product in a manner in which it was not originally intended
- Causes that were not foreseeable with the scientific and technological understanding at the time of shipment from Yaskawa
- Events for which Yaskawa is not responsible, such as natural or human-made disasters

◆ Limitations of Liability

- Yaskawa shall in no event be responsible for any damage or loss of opportunity to the customer that arises due to failure of the delivered product.
- Yaskawa shall not be responsible for any programs (including parameter settings) or the results of program execution of the programs provided by the user or by a third party for use with programmable Yaskawa products.
- The information described in product catalogs or manuals is provided for the purpose of the customer purchasing the appropriate product for the intended application. The use thereof does not guarantee that there are no infringements of intellectual property rights or other proprietary rights of Yaskawa or third parties, nor does it construe a license.
- Yaskawa shall not be responsible for any damage arising from infringements of intellectual property rights or other proprietary rights of third parties as a result of using the information described in catalogs or manuals.

◆ Suitability for Use

- It is the customer's responsibility to confirm conformity with any standards, codes, or regulations that apply if the Yaskawa product is used in combination with any other products.
- The customer must confirm that the Yaskawa product is suitable for the systems, machines, and equipment used by the customer.
- Consult with Yaskawa to determine whether use in the following applications is acceptable. If use in the application is acceptable, use the product with extra allowance in ratings and specifications, and provide safety measures to minimize hazards in the event of failure.
 - Outdoor use, use involving potential chemical contamination or electrical interference, or use in conditions or environments not described in product catalogs or manuals
 - Nuclear energy control systems, combustion systems, railroad systems, aviation systems, vehicle systems, medical equipment, amusement machines, and installations subject to separate industry or government regulations
 - Systems, machines, and equipment that may present a risk to life or property
 - Systems that require a high degree of reliability, such as systems that supply gas, water, or electricity, or systems that operate continuously 24 hours a day
 - Other systems that require a similar high degree of safety
- Never use the product for an application involving serious risk to life or property without first ensuring that the system is designed to secure the required level of safety with risk warnings and redundancy, and that the Yaskawa product is properly rated and installed.
- The circuit examples and other application examples described in product catalogs and manuals are for reference. Check the functionality and safety of the actual devices and equipment to be used before using the product.
- Read and understand all use prohibitions and precautions, and operate the Yaskawa product correctly to prevent accidental harm to third parties.

◆ Specifications Change

The names, specifications, appearance, and accessories of products in product catalogs and manuals may be changed at any time based on improvements and other reasons. The next editions of the revised catalogs or manuals will be published with updated code numbers. Consult with your Yaskawa representative to confirm the actual specifications before purchasing a product.

Contents

About this Manual	iii
Using this Manual	iii
Related Manuals	v
Safety Precautions	viii
Warranty	xiii

1

Introduction

1.1	Definition of Terms	1-2
1.1.1	MP3300	1-2
1.1.2	Racks	1-2
1.1.3	Main Rack and Expansion Racks	1-2
1.1.4	Rack Numbers	1-3
1.1.5	Slot Numbers	1-4
1.2	System Configuration Example	1-5
1.3	Devices and Components That Are Required to Build a System.	1-6
1.3.1	MP3300 Module/Unit List	1-7
1.3.2	Optional Modules	1-8
1.4	Precautions When Setting the Parameters	1-10
1.4.1	Precautions When Setting the Circuit Numbers	1-10
1.4.2	Precautions When Setting Module Configuration Definitions	1-10

2

Appearances and Parts

2.1	CPU Module	2-2
2.1.1	Appearance and Part Names	2-2
2.1.2	Display and Indicators	2-4
2.1.3	Switches	2-7
2.1.4	Connectors	2-9
2.1.5	Temperature Sensor	2-10
2.2	Base Units	2-11
2.2.1	Appearance and Part Names	2-11
2.2.2	Connector	2-11

3

CPU Module Functionality

3.1	Basic Functionality	3-2
3.1.1	Programs	3-2
3.1.2	Registers	3-17
3.1.3	Execution Scheduling	3-28
3.1.4	Scans	3-29
3.2	Function Modules	3-35
3.2.1	Self Configuration	3-35
3.2.2	Communications Function Module (218IFD)	3-45
3.2.3	Motion Control Function Modules (SVC, SVC32, SVR, and SVR32)	3-47
3.2.4	The M-EXECUTOR	3-53
3.2.5	Data Logging	3-66
3.2.6	USB Memory	3-87
3.2.7	File Transfer	3-91
3.2.8	Security	3-101
3.2.9	Calendar	3-101
3.2.10	Maintenance Monitoring	3-102

4

Specifications

4.1	Installation and Usage Conditions	4-2
4.1.1	Installation and Operating Conditions	4-2
4.1.2	Control Panel Cooling Method	4-3
4.2	CPU Module Specifications	4-4
4.2.1	Hardware Specifications	4-4
4.2.2	Performance Specifications	4-5
4.2.3	Communications Specifications	4-8
4.2.4	Motion Control Function Module Specifications	4-9
4.2.5	M-EXECUTOR Specifications	4-10
4.2.6	USB Memory Specifications	4-11
4.2.7	System Register Specifications	4-11
4.3	Base Unit Specifications	4-60

5

External Dimensions

5.1	CPU Module	5-2
5.2	Base Units	5-3

Index

Revision History

Introduction



This chapter introduces the MP3300.

1.1	Definition of Terms	1-2
1.1.1	MP3300	1-2
1.1.2	Racks	1-2
1.1.3	Main Rack and Expansion Racks	1-2
1.1.4	Rack Numbers	1-3
1.1.5	Slot Numbers	1-4
1.2	System Configuration Example	1-5
1.3	Devices and Components That Are Required to Build a System . .	1-6
1.3.1	MP3300 Module/Unit List	1-7
1.3.2	Optional Modules	1-8
1.4	Precautions When Setting the Parameters . .	1-10
1.4.1	Precautions When Setting the Circuit Numbers . .	1-10
1.4.2	Precautions When Setting Module Configuration Definitions	1-10

1.1 Definition of Terms

This section defines terms that have specific meanings in this manual.

1.1.1 MP3300

“MP3300” is a collective term that refers to the following CPU Modules and Base Units.

Name	Primary Function
CPU Module	Stores the module definitions and programs, and interprets the programs. The CPU Module also controls the Optional Modules.
Base Unit	Provides the backplane to which Modules are mounted and supplies the required power to the Modules.

1.1.2 Racks

A Rack is a Base Unit with Modules mounted to it.

Connection Example

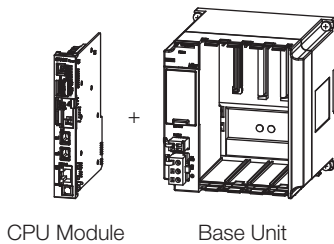

1.1.3 Main Rack and Expansion Racks

You can add Units and Optional Modules to a Rack to expand functionality. However, if a restriction such as the power supply capacity or number of Base Unit slots for one Rack is exceeded, you must add an Expansion Rack.

You can achieve the following things by adding Units or Optional Modules to a Rack.

- Increase the number of Optional Modules that you can use.
- Increase the number of axes that are controlled.

If you add Racks, the Racks are classified into the Main Rack and Expansion Racks.

Type	Description
Main Rack	The Main Rack contains the Main CPU Module. There can be only one Main Rack in any one system configuration.
Expansion Racks	Expansion Racks are connected to the Main Rack. You can connect up to three Expansion Racks to the Main Rack. (The Expansion Racks use EXIOIF Modules.)

Refer to the following section for an expansion example.

MP3300 Expansion Example on page 1-3

MP3300 Expansion Example

An MP3300 expansion example is given in the following figure.

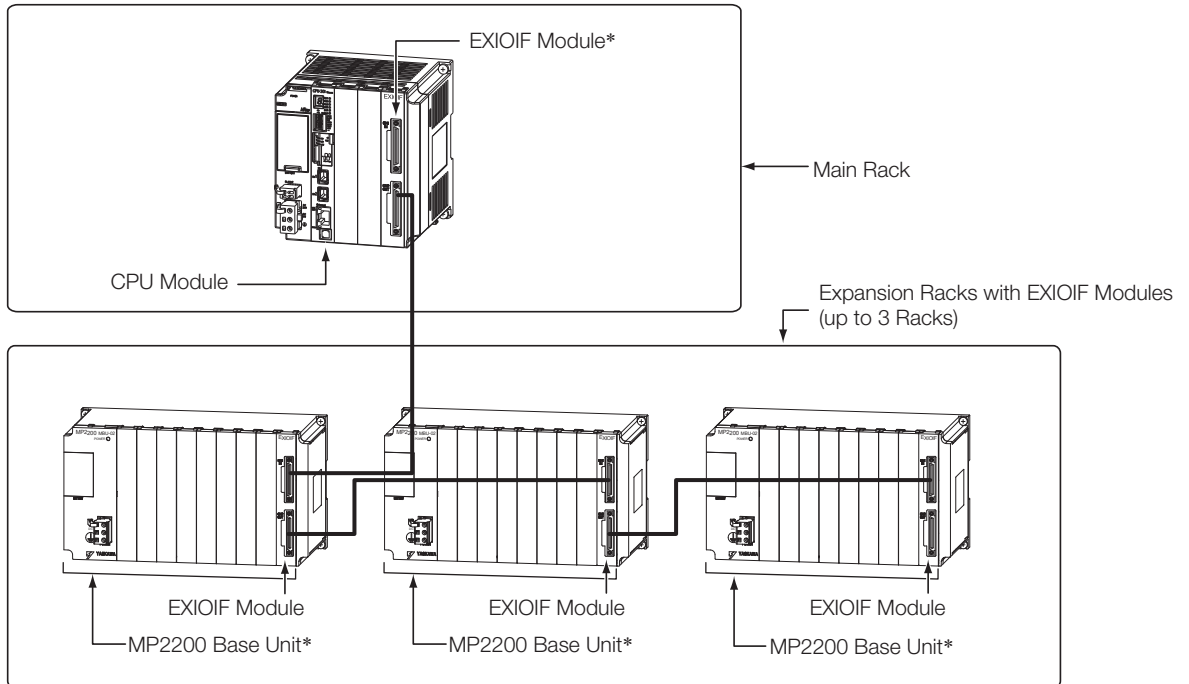

* Refer to the following manual for details on the MP2200 Base Unit and EXIOIF Module.
 📖 MP2200 Series User's Manual (Manual No.: SIEP C880700 14)

1.1.4 Rack Numbers

When you add Expansion Racks, the MPE720 automatically assigns a number to each Rack so that the Racks can be identified.

Rack No.	Description
Rack 1	Main Rack
Rack 2	Expansion Racks added by using EXIOIF Modules
Rack 3	
Rack 4	

The following figure illustrates Rack numbers.

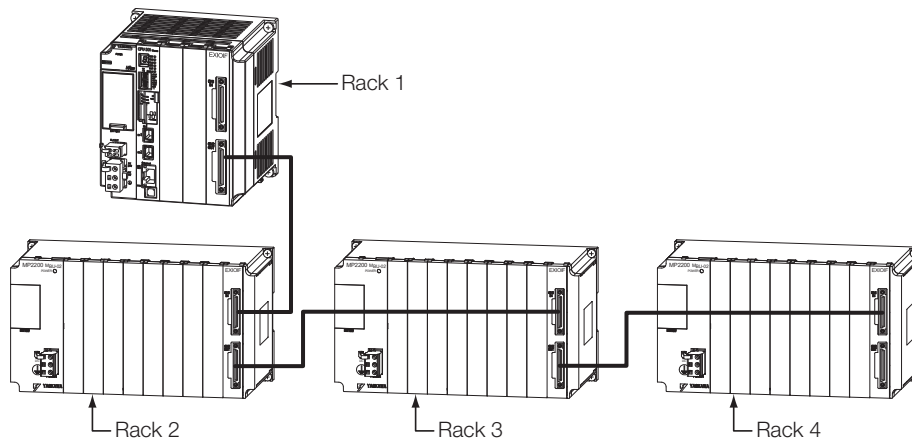

1.1.5 Slot Numbers

The MPE720 automatically assigns slot numbers to the slots on the Base Unit so that the slots can be identified.

Numbers 1 to 9 are assigned to the slots in order from the left. The highest slot number depends on the specifications of the Base Unit.

1.2 System Configuration Example

The following figure shows a typical system configuration. Refer to the following section for details on 1 to 12 in the following figure.

1.3 Devices and Components That Are Required to Build a System on page 1-6

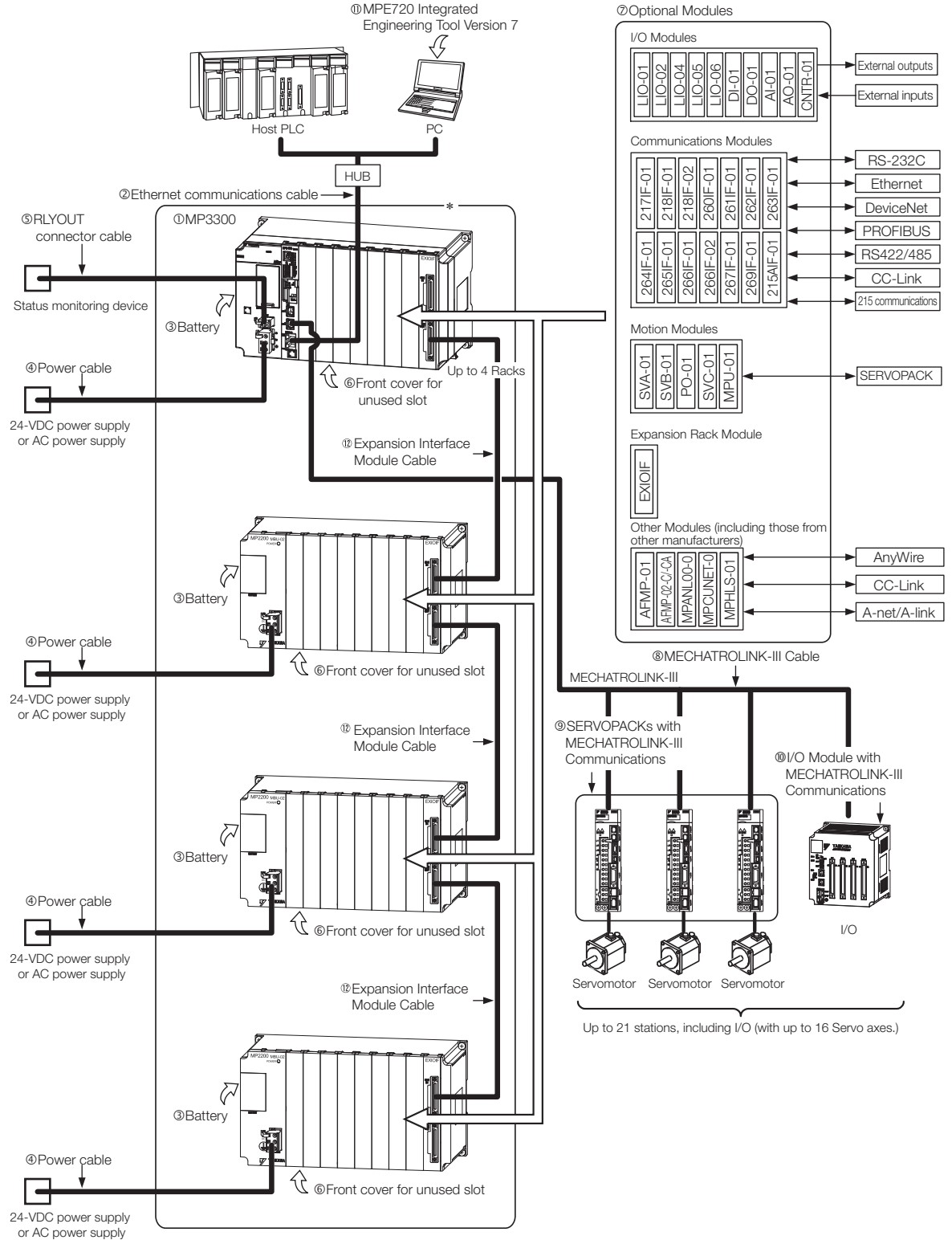

* This manual primarily describes this area.



Note: Supplying Power When Using Expansion Racks

- Either supply power simultaneously to both the Main Rack and Expansion Racks or supply power to the Expansion Racks first.
- If you turn the power supply OFF and ON again to an Expansion Rack, turn the power supply OFF and ON again to the Main Rack as well. (Unless of course you turn the power supply OFF and ON again simultaneously.)

1.3 Devices and Components That Are Required to Build a System

The following table lists the devices and components that are required to build the system that is shown below. The numbers ① to ⑨ correspond to the numbers in the figure that is shown below.

 1.2 System Configuration Example on page 1-5

No.	Name	Use	Model	Remarks
①	CPU Module	Stores the module definitions and programs, and interprets the programs. The CPU Module also controls the Optional Modules.		Refer to the following section for details.  1.3.1 MP3300 Module/Unit List on page 1-7
	MP3300	Base Unit		
②	Ethernet communications cables	Used to connect the CPU Module to Ethernet communications devices or to connect the CPU Module to a PC that has the MPE720 installed on it.		Use a commercially available cable that meets the following conditions: <ul style="list-style-type: none"> • Ethernet specification: 100Base-TX • Category 5 or higher • Twisted-pair cable with RJ-45 connectors
③	Battery with Special Connector	Provides power for the calendar and backup memory while the power is turned OFF.	JZSP-BA01	The Battery is provided with the CPU Module.
④	Power supply cable	Connects the power supply of the Base Unit to a 24-VDC power supply or an AC power supply.		Use a commercially available cable that meets the following conditions: <ul style="list-style-type: none"> • Wire size: AWG18 to AWG13 (0.8 to 2.6 mm²) • Twisted-pair cable
⑤	RLYOUT connector cable	Connects the power supply of the Base Unit to a status monitoring device.		Use a commercially available cable that meets the following conditions: <ul style="list-style-type: none"> • Wire size: AWG28 to AWG14 (0.08 to 2.0 mm²)
⑥	Front cover for unused slot	Used to cover unused slots on the Base Unit.	JEPMC-OP3301-E	-
⑦	Optional Modules	Motion Modules, I/O Modules, and Communications Modules are selected based on the application.		Refer to the following section for details.  1.3.2 Optional Modules on page 1-8
⑧	MECHATROLINK-III Cable	Connects the CPU Module to MECHATROLINK-III communications devices.	JEPMC-W6012-□□-E	Standard cable Length: 0.2 to 50 m
			JEPMC-W6013-□□-E	Cable with ferrite cores Length: 10 to 50 m
			JEPMC-W6014-□□-E	Cable with loose wires at one end Length: 0.5 to 50 m
⑨	SERVOPACK with MECHATROLINK-III Communications	Used to control Servomotors.	SGD7S-□□□□ 20□□□□□□	Σ7S (Single-axis) AC SERVOPACK with MECHATROLINK-III Commu- nications
			SGD7W-□□□□ 20□□□□□□	Σ7W (Two-axis) AC SERVOPACK with MECHATROLINK-III Commu- nications

Continued on next page.

Continued from previous page.

No.	Name	Use	Model	Remarks
⑩	I/O Modules with MECHATROLINK-III Communications	64-point I/O Module	JEPMC-MTD2310-E	24 VDC, 64 inputs, 64 outputs
		Analog Input Module	JEPMC-MTA2900-E	8 analog input channels
		Analog Output Module	JEPMC-MTA2910-E	4 analog output channels
		Pulse Train Input Module	JEPMC-MTP2900-E	2 pulse-train inputs
		Pulse Train Output Module	JEPMC-MTP2910-E	4 pulse-train outputs
⑪	MPE720 Integrated Engineering Tool Version 7	Used to adjust, maintain, and program AC Servo Drives and Inverters that are connected to the network.	CPMC-MPE780D	–
⑫	Expansion Interface Module Cables	Used to use an Expansion Interface Module to connect the Main Rack to an Expansion Rack or to connect two Expansion Racks.	JEPMC-W2094-A5-E	Length: 0.5 m
			JEPMC-W2094-01-E	Length: 1.0 m
			JEPMC-W2094-2A5-E	Length: 2.5 m
–	Panel-mounting Bracket	Used to mount the MP3300 inside a control panel.	JEPMC-OP2300S-E	–

1.3.1 MP3300 Module/Unit List

The following table lists the MP3300 Modules and Units.

Type	Abbreviation	Model	Description	
CPU Module for 16 axes	CPU-301 (16 axes)	JAPMC-CP3301-1-E	–	
	CPU-302 (16 axes)	JAPMC-CP3302-1-E	–	
	Motion Control Function Modules	SVC	–	MECHATROLINK-III
		SVR	–	Virtual axes*
Communications Function Module	218IFD	–	Ethernet	
CPU Module for for 32 axes	CPU-301 (32 axes)	JAPMC-CP3301-2-E	–	
	CPU-302 (32 axes)	JAPMC-CP3302-2-E	–	
	Motion Control Function Module	SVC32	–	MECHATROLINK-III
		SVR32	–	Virtual axes*
Communications Function Module	218IFD	–	Ethernet	
Base Unit	MBU-301	JEPMC-BU3301-E	8 slots	
	MBU-302	JEPMC-BU3302-E	8 slots	
	MBU-303	JEPMC-BU3303-E	3 slots	
	MBU-304	JEPMC-BU3304-E	1 slot	

* Refer to the following section for details.

 3.2.3 Motion Control Function Modules (SVC, SVC32, SVR, and SVR32) on page 3-47

1.3.2 Optional Modules

You can add the Optional Modules that are listed in the following table for as many open slots there are in the Base Unit.

Unit	Abbreviation	Model	Description	Compatible CPU Module Version
Motion Modules	SVC-01	JAPMC-MC2320-E	MECHATROLINK-III × 1	All versions
	SVB-01	JAPMC-MC2310-E	MECHATROLINK-II × 1	
	SVA-01	JAPMC-MC2300	2-axis analog servo interface	
	PO-01	JAPMC-PL2310-E	4-axis control with pulse-train output	
	MPU-01	JAPMC-CP2700-E	Optional Module with CPU Module and SVC-01 functionality MECHATROLINK-III × 1	
Communications Modules	215AIF-01	JAPMC-CM2360-E	RS-232C/MPLINK communications	All versions
		JAPMC-CM2361	RS-232C/CP-215 communications	
	217IF-01	JAPMC-CM2310-E	RS-232C/RS-422 communications	
	218IF-01	JAPMC-CM2300-E	RS-232C/Ethernet communications (10Base-T)	
	218IF-02	JAPMC-CM2302-E	RS-232C/Ethernet communications (100Base-TX/10Base-T)	
	260IF-01	JAPMC-CM2320-E	RS-232C/DeviceNet communications	
	261IF-01	JAPMC-CM2330-E	RS-232C/PROFIBUS communications	
	262IF-01	JAPMC-CM2303-E	FL-net communications	
	263IF-01	JAPMC-CM2304-E	EtherNet/IP communications	
	264IF-01	JAPMC-CM2305-E	EtherCAT (EtherCAT slave)	
	265IF-01	JAPMC-CM2390-E	CompoNet (I/O communications and message communications)	
	266IF-01	JAPMC-CM2306-E	PROFINET (PROFINET master)	
	266IF-02	JAPMC-CM2307-E	PROFINET (PROFINET slave)	
	267IF-01	JAPMC-CM23A0	CC-Link communications (CC-Link master)	
269IF-01	JAPMC-CM2308-E	CC-Link IE Field communications (CC-Link IE Field slave)	Version 1.32 or higher	
Communications Modules (from other manufacturers)	AFMP-01	–	AnyWire-Master DB by Anywire Corporation	All versions
	AFMP-02-C	–	CC-Link by Anywire Corporation	
	AFMP-02-CA	–	CC-Link and AnyWire-Master DB by Anywire Corporation	
	MPANL00-0	–	A-net/A-Link by ALGO System	
	MPCUNET-0	–	CUnet by ALGO System	
	MPHLS-01	–	HLS by M-System Co.,Ltd.	Version 1.12 or higher

Continued on next page.

Continued from previous page.

Unit	Abbreviation	Model	Description	Compatible CPU Module Version
I/O Modules	LIO-01	JAPMC-IO2300-E	16 inputs, 16 sinking outputs 1 pulse-train input	All versions
	LIO-02	JAPMC-IO2301-E	16 inputs, 16 sourcing outputs 1 pulse-train input	
	LIO-04	JAPMC-IO2303-E	32 inputs, 32 sinking outputs	
	LIO-05	JAPMC-IO2304-E	32 inputs, 32 sourcing outputs	
	LIO-06	JAPMC-IO2305-E	8 digital inputs, 8 digital sinking outputs 1 analog input channel and 1 analog output channel 1 pulse-train counter channel	
	DI-01 (Currently under development)	JAPMC-DI2300-E	64 inputs	Version 1.45 or higher
	DO-01	JAPMC-DO2300-E	64 sinking outputs	All versions
	AI-01	JAPMC-AN2300-E	8 analog input channels	
	AO-01	JAPMC-AN2310-E	4 analog output channels	
	CNTR-01	JAPMC-PL2300-E	2 counter channels, input circuits: 5 V or 12 V	
Rack Expansion Modules	EXIOIF	JAPMC-EX2200-E	–	All versions

* Refer to the manuals for individual Optional Modules for details.

1.4 Precautions When Setting the Parameters

Observe the following precautions when setting the Machine Controller.

1.4.1 Precautions When Setting the Circuit Numbers

When assigning circuit numbers to the Motion Control and Communications Function Modules, the numbers must be within the following ranges.

Unit		Abbreviations of Built-in Modules	Circuit numbers
Function Modules in CPU Module	Motion Control Function Module	SVC and SVR	1 to 16
		SVC32 and SVR32	1 to 16
	Communications Function Module	218IFD	1 to 8
Optional Modules	Motion Modules	SVA-01 (SVA), SVB-01 (SVB01), SVC-01 (SVC), MPU-01 (MPUIF), PO-01 (PO)	1 to 16
		217IF-01 (217IF)	1 to 16
	Communications Modules	218IF-01 (218IF), 218IF-02 (218IFB), 260IF-01 (260IF (DeviceNet)), 261IF-01 (261IFS (Profibus)), 262IF-01 (FL-net), 263IF-01 (EtherNet/IP), 264IF-01 (EtherCAT-S), 265IF-01 (Componet), 266IF-01, 266IF-02, 267IF-01 (CC-Link), 269IF-01 (CC-Link IE Field), 215AIF-01 (MPLINK), 215AIF-01 (CP-215)	1 to 8

1.4.2 Precautions When Setting Module Configuration Definitions

Observe the following precautions when writing module configuration definitions.

- Write the module configuration definitions only when the high-speed scan has sufficient unused processing time.
Otherwise, processing may exceed the time limit of the high-speed scan.
- Before writing module configuration definitions, make sure the machine is not in operation.
- Before you use the Machine Controller, save any written data to flash memory and turn the power supply to the Racks OFF and ON again.

Appearances and Parts

2

This section describes the appearance and parts of the MP3300.

2.1	CPU Module	2-2
2.1.1	Appearance and Part Names	2-2
2.1.2	Display and Indicators	2-4
2.1.3	Switches	2-7
2.1.4	Connectors	2-9
2.1.5	Temperature Sensor	2-10
2.2	Base Units	2-11
2.2.1	Appearance and Part Names	2-11
2.2.2	Connector	2-11

2.1 CPU Module

The CPU Module stores the module definitions and programs, and interprets the programs. The CPU Module also controls the Optional Modules.

This section shows the appearance and part names of the CPU Module and describes the indicators, switches, and connectors.

2.1.1 Appearance and Part Names

The following figure shows the appearance of the CPU Module and the part names.

CPU-301

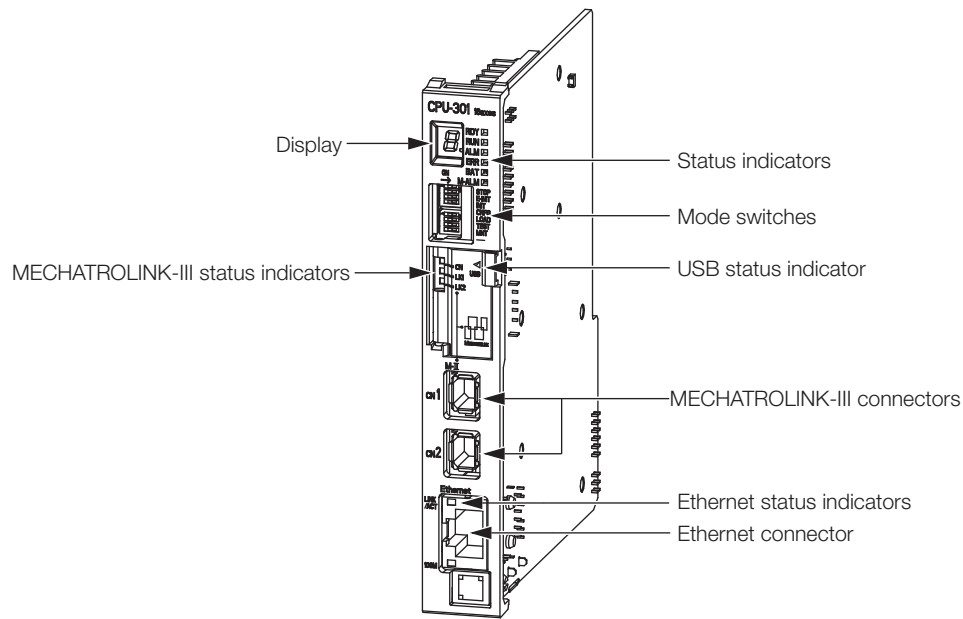

CPU-302

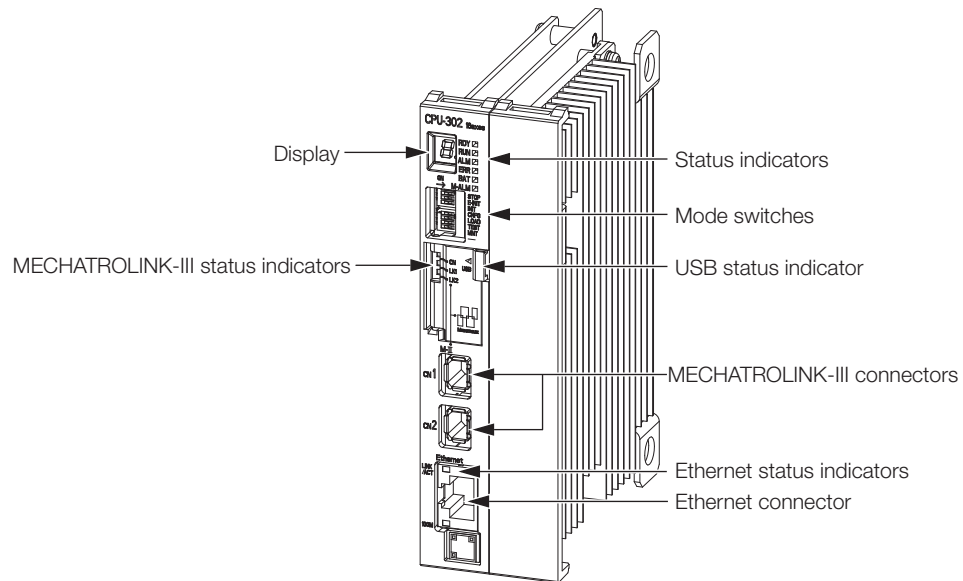

◆ Precautions When Using a CPU-302 Module

The CPU-302 Module uses the CPU Slot and one option slot. As shown below, the number of usable Option Modules will be reduced by one when you mount the CPU-302 to any Base Unit.

MBU-301 or MBU-302 (Eight Slots)

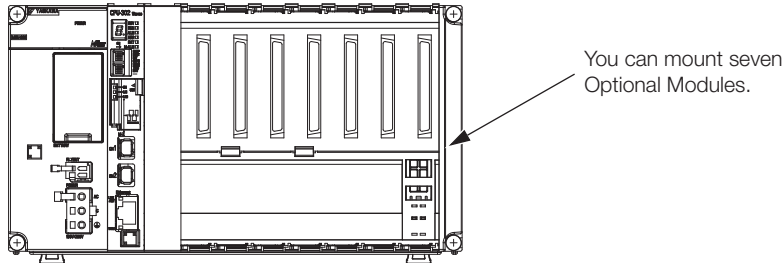

MBU-303 (Three Slots)

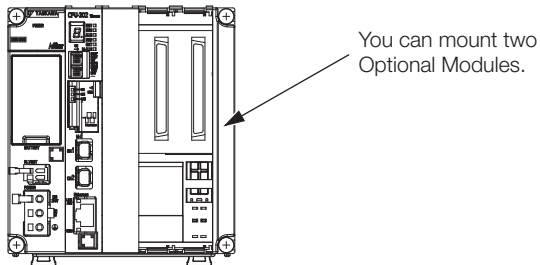

MBU-304 (One Slot)

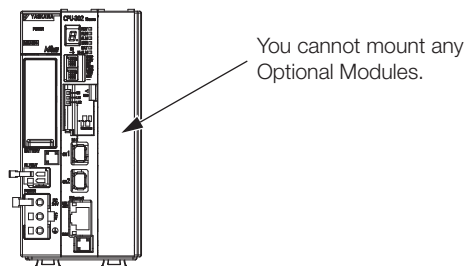





2.1.2 Display and Indicators

The CPU Module has the following display and four types of indicators.

- Display
- Status indicators
- USB status indicator
- MECHATROLINK-III status indicators
- Ethernet status indicators

Display

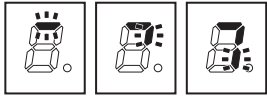
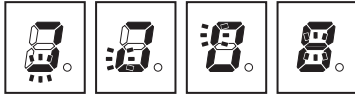
The display shows the execution or error status of the CPU Module.

Color	Display	Status	Description
Red	 Lit dot at lower right	Initializing (The RDY status indicator is not lit.)	The CPU Module started normally after the power was turned ON or after the system was reset.
	 Flashing dot at lower right	CPU stopped	The CPU is stopped.
		USB memory batch transfer	Save or load is starting.
			Save or load is in progress.
			Save or load was completed. After 2 seconds, the display will indicate the status of the CPU Module.
			
	Three digits after E. or A.	A system error occurred.	Refer to the following manual for details on errors.  MP3000 Series Machine Controller System Troubleshooting Manual (Manual No.: SIEP C880725 01)
	An alarm occurred.		

Status Indicators

These indicators show the status of the CPU Module.

- RDY
- RUN
- ALM
- ERR
- BAT
- M-ALM



Indicator Name	Color	Status When Lit*
RDY	Green	Operation is normal.
RUN	Green	A user program is being executed.
ALM	Red	An alarm occurred.
ERR	Red	An error occurred.
BAT	Red	The battery alarm occurred.
M-ALM	Red	An error occurred with one of the Servo axes: <ul style="list-style-type: none"> • Warning • Alarm • Command Error Completed Status

* Refer to the following manual for details.

 *MP3000 Series Machine Controller System Troubleshooting Manual (Manual No.: SIEP C880725 01)*



USB Status Indicator

This indicator shows the status of the USB memory.

Indicator Name	Indicator Status	Status	Description
USB ACTIVE	 Not lit	No USB mem- ory device	No USB memory device has been inserted yet, or the USB memory device is ready to be removed.
	 Lit	USB memory device inserted	A USB memory device is inserted.
	 Flashing	Accessing USB memory	The USB memory is being accessed.

MECHATROLINK-III Status Indicators

These indicators show the status of the MECHATROLINK-III communications.

-  CN
-  LK1
-  LK2

Indicator Name	Color	Status When Lit
CN	Green	MECHATROLINK-III communications is established with the CPU Module as a slave (i.e., the Connect command is ON).
LK1	Green	MECHATROLINK-III communications are active on PORT1.
LK2	Green	MECHATROLINK-III communications are active on PORT2.

Ethernet Status Indicators

These indicators show the status of Ethernet communications.

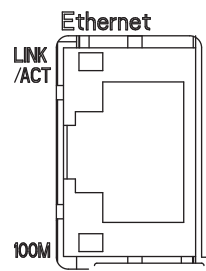

Indicator Name	Color	Status When Not Lit, Lit, or Flashing
LINK/ACT	Yellow	Lit: Ethernet link established. Flashing: Ethernet communications activity.
100M	Green	Not lit: 10 M connection Lit: 100 M connection

2.1.3 Switches

The CPU Module has the following two types of switches.

- DIP switches: Mode switches
- STOP/SAVE switch

DIP Switches: Mode Switches

These DIP switches primarily set the operating mode of the CPU Module.

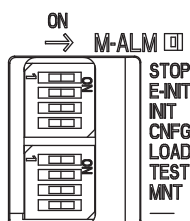

Pin Name	Status	Operating Mode	Default	Remarks
STOP	ON	Stops the user programs.	OFF	Turn ON the pin to stop execution of the user program.
	OFF	Executes the user programs.		
E-INIT	ON	Sets the default IP address.	OFF	If this pin is set to ON, the IP address is set to 192.168.1.1. If this pin is set to OFF, the IP address for the definition that is stored in flash memory is used. If there is no definition stored in flash memory, the IP address is set to 192.168.1.1.
	OFF	Does not set the default IP address.		
INIT	ON	Resets memory.	OFF	Turn OFF the pin to execute the programs that are stored in the flash memory.
	OFF	Normal operation		
CNFG	ON	Configuration Mode	OFF	Turn ON the pin to perform self configuration. Turn OFF the pin to operate according to the definitions that are stored in the flash memory.
	OFF	Normal operation		
LOAD	ON	Loads data.	OFF	Turn ON the pin and then turn ON the power to batch load data from the USB memory to the CPU Module. Refer to the following section for details.  3.2.6 USB Memory on page 3-87
	OFF	Does not load data.		
TEST	ON	Reserved for system.	OFF	Keep this pin OFF at all times.
	OFF	Normal operation		
MNT	ON	Reserved for system.	OFF	Keep this pin OFF at all times.
	OFF	Normal operation		
-	ON	Reserved for system.	OFF	-
	OFF	Normal operation		

STOP/SAVE Switch

This switch is used when removing the USB memory device, or when batch saving data to the USB memory.

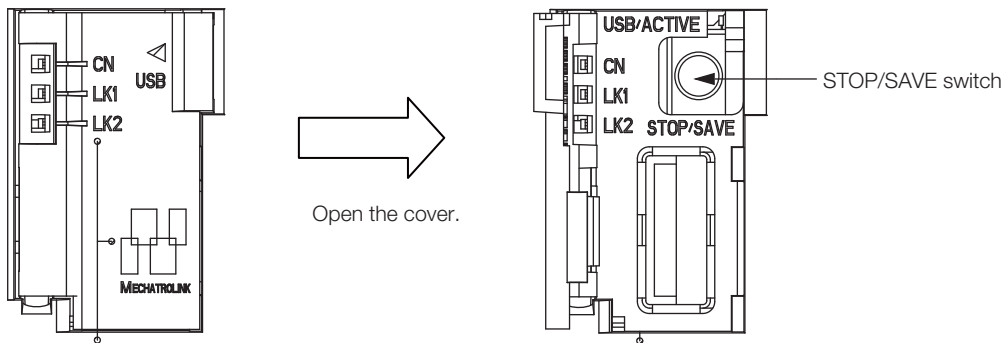

- Lightly press this switch to prepare the USB memory device for removal. The USB memory device can be safely removed when the USB status indicator changes from flashing to not lit.
- Press and hold this switch for at least 2 seconds to save all of the data to the USB memory. The display will show the progress of saving.

2.1.4 Connectors

The CPU Module has three types of connectors: MECHATROLINK-III, Ethernet, and USB.

MECHATROLINK-III Connectors

These connectors are used to connect MECHATROLINK-III communications devices.

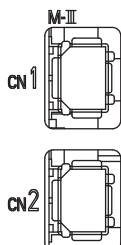

Ethernet Connectors

These connectors are used to connect Ethernet communications devices.

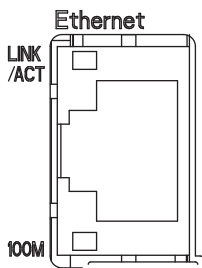

USB Connector

This connector is used to connect a USB memory device.

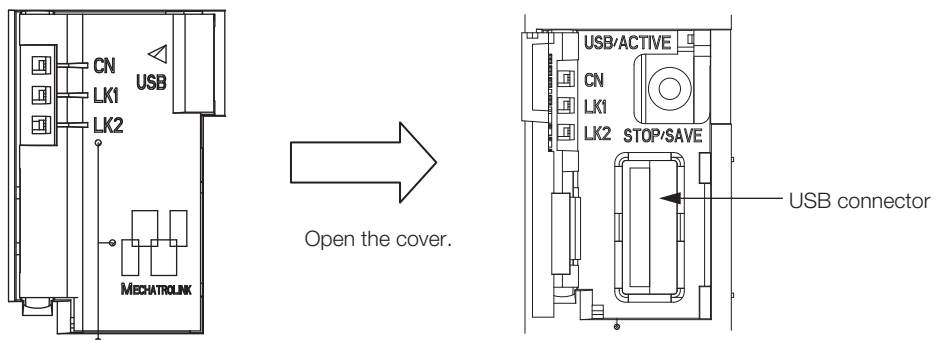

Before removing the USB memory device, press the STOP/SAVE switch and wait until the USB status indicator goes out. If the USB memory device is removed while the USB status indicator is lit or flashing, the data may become corrupted.

2.1.5 Temperature Sensor

A temperature sensor is built into the CPU Module.

The temperature sensor constantly monitors for abnormal temperatures in the CPU Module. If a temperature error is detected, an alarm is displayed on the CPU Module.

There are four levels of alarms, as shown in the following table.

Display	ALM Indicator	Error Description
A.241	Lit	A rise in the internal temperature was detected.
E.081	Lit	The temperature continued to increase after A.241 was detected and is approaching the permissible temperature of the internal parts. (The CPU Module will stop.)
E.082	Lit	The temperature continued to increase after E.081 was detected and has reached the permissible temperature of the internal parts. (The CPU Module will stop.)
h	Lit	The failsafe function was activated for E.082 (Temperature Warning). (The CPU Module will stop.) (This alarm is displayed if the temperature continues to increase after E.082 was detected.)



Important

If any one of the above alarms occurs, take the following actions.

- A.241: Check the ambient environment and installation conditions. If you are using natural cooling for the control panel, we recommend that you change to forced-air cooling.
- E.081, E.082, or h: Turn OFF the power supply to the Machine Controller immediately and check the ambient environment and installation conditions.

Refer to the following section for details on the ambient environment and installation requirements.

 [4.1 Installation and Usage Conditions](#) on page 4-2

2.2 Base Units

The Base Unit provides the backplane to which Modules are mounted and supplies the required power to the Modules. There are two models of Base Units, a one-slot model and a three-slot model.

This section shows the appearance and part names of the Base Unit and describes the connector.

2.2.1 Appearance and Part Names

The following figure shows the appearance of the Base Unit and a part name.

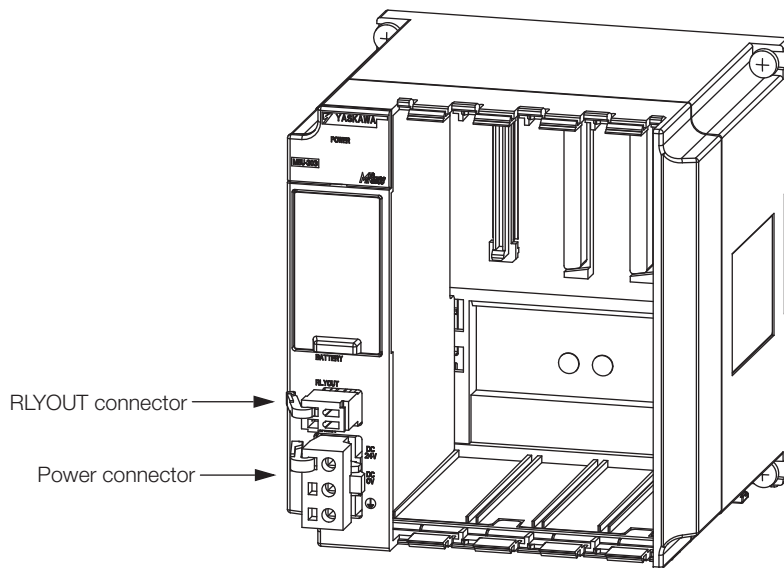

2.2.2 Connector

The Base Unit has two connectors: an RLYOUT connector and a power connector.

RLYOUT Connector

This connector outputs the status of the CPU Module.

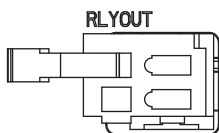

Model: 734-302

◆ Pin Assignments

No.	Signal Label	Description
1	OUT	<ul style="list-style-type: none"> • Normal operation: Circuit closed. • Error: Circuit open.
2	OUT	

Power Connector

Connect the power supply to this connector.

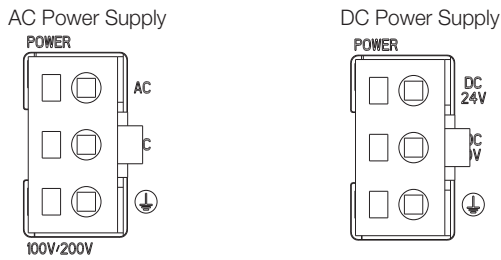

Type	Model	Color
AC power supply	3-2134249-3	Black
DC power supply	4-2013522-3	White

◆ Pin Assignments: AC Power Supply

Pin No.	Signal Label	Description
3	AC	AC input
2	AC	AC input
1	FG	Connects to the frame ground. (Ground to 100 Ω max.)

◆ Pin Assignments: DC Power Supply

Pin No.	Signal Label	Description
3	DC24 V	24-VDC input
2	DC0 V	0-VDC input
1	FG	Connects to the frame ground. (Ground to 100 Ω max.)

CPU Module Functionality

3

This chapter describes the functionality of the MP3300 CPU Module.

3.1 Basic Functionality 3-2

- 3.1.1 Programs 3-2
- 3.1.2 Registers 3-17
- 3.1.3 Execution Scheduling 3-28
- 3.1.4 Scans 3-29

3.2 Function Modules 3-35

- 3.2.1 Self Configuration 3-35
- 3.2.2 Communications Function Module (218IFD) . . . 3-45
- 3.2.3 Motion Control Function Modules
(SVC, SVC32, SVR, and SVR32) 3-47
- 3.2.4 The M-EXECUTOR 3-53
- 3.2.5 Data Logging 3-66
- 3.2.6 USB Memory 3-87
- 3.2.7 File Transfer 3-91
- 3.2.8 Security 3-101
- 3.2.9 Calendar 3-101
- 3.2.10 Maintenance Monitoring 3-102

3.1 Basic Functionality

This section describes the basic functionality of the CPU Module.

3.1.1 Programs

A program is a list of instructions to be processed by the CPU Module.

This section describes the types of programs and gives an overview of each type.

Types of Programs

There are three types of user programs:

- Ladder programs
- Motion programs
- Sequence programs

This section describes these programs.

◆ Ladder Programs

Ladder programs are managed as drawings (ladder diagrams) that are identified by their drawing numbers (DWG numbers). These drawings form the basis of the user program.

■ Drawing Types and Hierarchical Configuration

This section describes the types of ladder drawings and their hierarchical configuration.

• Types

Ladder drawings are divided into four different types based on their purpose.

- DWG.A (Startup Drawings)
This type of ladder drawing is used to set register data. These ladder drawings are executed before high-speed scan process drawings and low-speed scan process drawings.
- DWG.I (Interrupt Drawings)
This type of ladder drawing is used to perform processing with priority given to signals input from an Optional Module. These ladder drawings are executed with higher priority than high-speed scan process drawings regardless of the scan cycle.
- DWG.H (High-speed Scan Process Drawings)
This type of ladder drawing is used to perform motion control or high-speed I/O control.
- DWG.L (Low-speed Scan Process Drawings)
This type of ladder drawing is used for communications with HMIs and external devices as well as for standard I/O control.

The following table lists the priority, execution conditions, and maximum number of drawings for each type of ladder drawing.

Drawing Type	Priority*	Execution Condition	Maximum Number of Drawings
DWG.A (Startup Drawings)	1	Power ON (These drawings are executed once when the power supply is turned ON.)	64
DWG.I (Interrupt Drawings)	2	External interrupt (These drawings are executed when a DI interrupt or counter match interrupt is received from an Option Module.)	64
DWG.H (High-speed Scan Process Drawings)	3	Started at fixed intervals. (These drawings are executed once every high-speed scan.)	1,000
DWG.L (Low-speed Scan Process Drawings)	4	Started at fixed intervals. (These drawings are executed once every low-speed scan.)	2,000

* Drawings with lower numbers have higher priority.

- **Hierarchical Configuration**

There are four types of ladder drawings: parent drawings, child drawings, grandchild drawings, and operation error drawings.

- **Parent Drawings**
These drawings are automatically executed by the system program when the execution conditions are met.
- **Child Drawings**
These drawings are executed when they are called from a parent drawing with a SEE instruction.
- **Grandchild Drawings**
These drawings are executed when they are called from a child drawing with a SEE instruction.
- **Operation Error Drawings**
These drawings are automatically executed by the system program when an operation error occurs.

A parent drawing cannot call a child drawing from a different type of drawing. Similarly, a child drawing cannot call a grandchild drawing from a different type of drawing. A parent drawing cannot call a grandchild drawing directly. The parent drawing first must call the child drawing, and then the child drawing must call the grandchild drawing. This is called the hierarchical configuration of drawings.

The following figure shows the parent-child-grandchild structure in which a program is created.

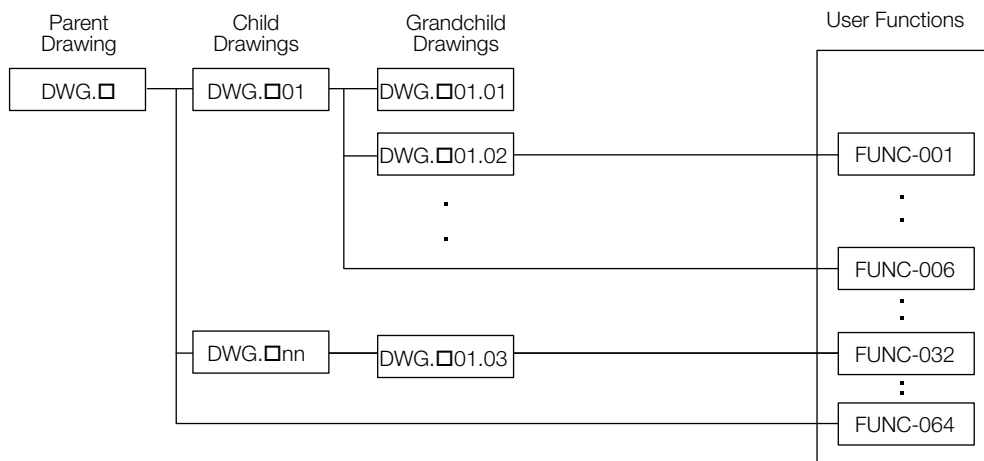

Note: □ = A, I, H, or L

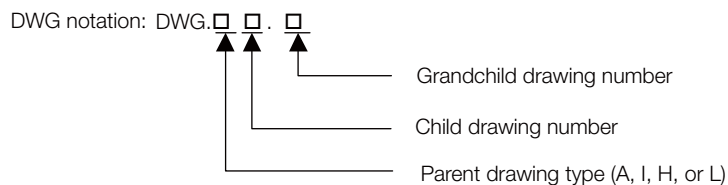

Note: The following notation is used for operation error drawings.

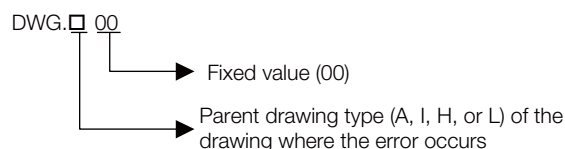

The breakdown of the number of ladder drawings in each category is given in the following table.

Drawings	Number of Drawings			
	DWG.A	DWG.I	DWG.H	DWG.L
Parent Drawings	1	1	1	1
Operation Error Drawings	1	1	1	1
Child Drawings	Total of 62 max.	Total of 62 max.	Total of 998 max.	Total of 1,998 max.
Grandchild Drawings				

Information There are separate functions that can be called from the drawings as required. Functions are executed when they are called from a parent, child, or grandchild drawing with the FUNC instruction. You can create up to 2,000 functions.

■ Execution Processing of Drawings

The drawings are executed by calling them from the top to the bottom, following the hierarchy of the drawings. The following figure illustrates the execution processing of a high-speed scan drawing (DWG.H).

Execution is started by the system program when the execution condition is met.

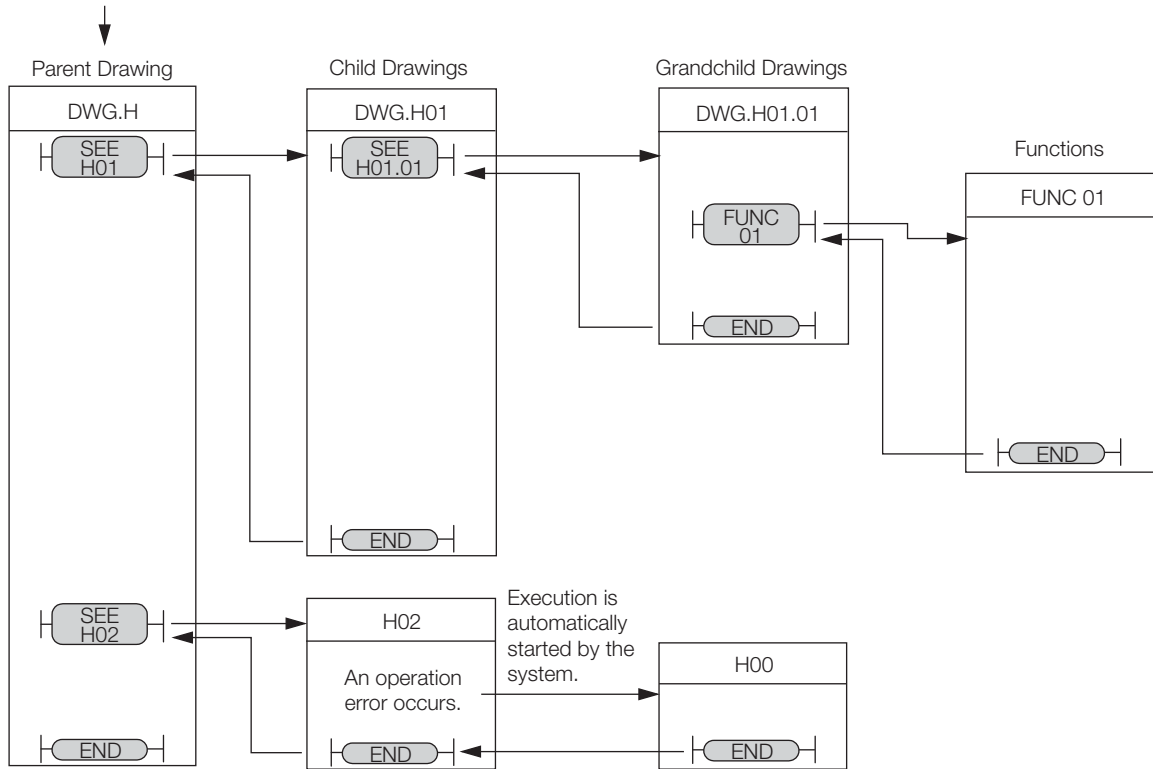

- Note:
1. The parent drawing is automatically called and executed by the system. Child drawings and grandchild drawings are executed by calling them from a parent drawing or a child drawing using the SEE instruction.
 2. You can call functions from any drawing. You can also call functions from other functions.
 3. If an operation error occurs, the operation error drawing for the drawing type will be started automatically.
 4. Always specify 00 as the drawing number for operation error drawings.

■ Functions

Functions are executed when they are called from a parent, child, or grandchild drawing with the FUNC instruction.

Functions can be freely called from any drawing. The same function can be called simultaneously from different types of drawings or different levels of drawings. You can also call functions from other functions that you have created.

The use of functions provides the following merits:

- Easy user program modularization
- Easy user program creation and maintenance

You can use standard functions that are provided by the system, and you can define user functions.

• Standard System Functions

The following functions for communications and other purposes are provided as standard functions in the system. You cannot change the system functions.

Function	Name
COUNTER	Counter
FINFOUT	First-in First-out
TRACE	Trace
DTRC-RD	Read Data Trace
DTRC-RDE	Read Data Trace Extended
MSG-SND	Send Message
MSG-SNDE	Send Message Extended
MSG-RCV	Receive Message
MSG-RCVE	Receive Message Extended
ICNS-WR	Inverter Parameter Write
ICNS-RD	Inverter Parameter Read
MLNK-SVW	Write SERVOPACK Parameter
MLNK-SVR	Read SERVOPACK Parameter
FLASH-OP	Flash Operation
MOTREG-W	Write Motion Register
MOTREG-R	Read Motion Register
IMPORT	Import
IMPORTL	Import Extended
EXPORT	Export
EXPORTL	Export Extended

• User Functions

You can freely program the body of a user function and program the user function definitions. A maximum of 2,000 user function drawings can be defined.

Information Refer to the following manual for details on how to define functions.
 MP3000 Series Ladder Programming Manual (Manual No.: SIEP C880725 13)

◆ Motion Programs

A motion program is a program that is written in a text-based motion language. There are two types of motion programs.

Type	Designation Method	Features	Number of Programs
Main programs	MPM□□□ (□□□=1 to 512)	<ul style="list-style-type: none"> Main programs are called from a DWG.H drawing. Main programs are called from the M-EXECUTOR program execution definitions. 	You can create up to 512 motion programs, including the following programs: <ul style="list-style-type: none"> Motion main programs Motion subprograms Sequence main programs Sequence subprograms
Subprograms	MPS□□□ (□□□=1 to 512)	Subprograms are called from a main program.	



Important

- The same numbers are used to manage the motion programs and sequence programs. Use a unique number for each program.
 - Motion program numbers are given in the form MPM□□□ or MPS□□□.
 - Sequence program numbers are given in the form SPM□□□ or SPS□□□.
- The number of motion programs that can be executed simultaneously depends on the model of the Machine Controller. If the number of simultaneously executable programs is exceeded, an alarm will occur (No System Work Available Error).

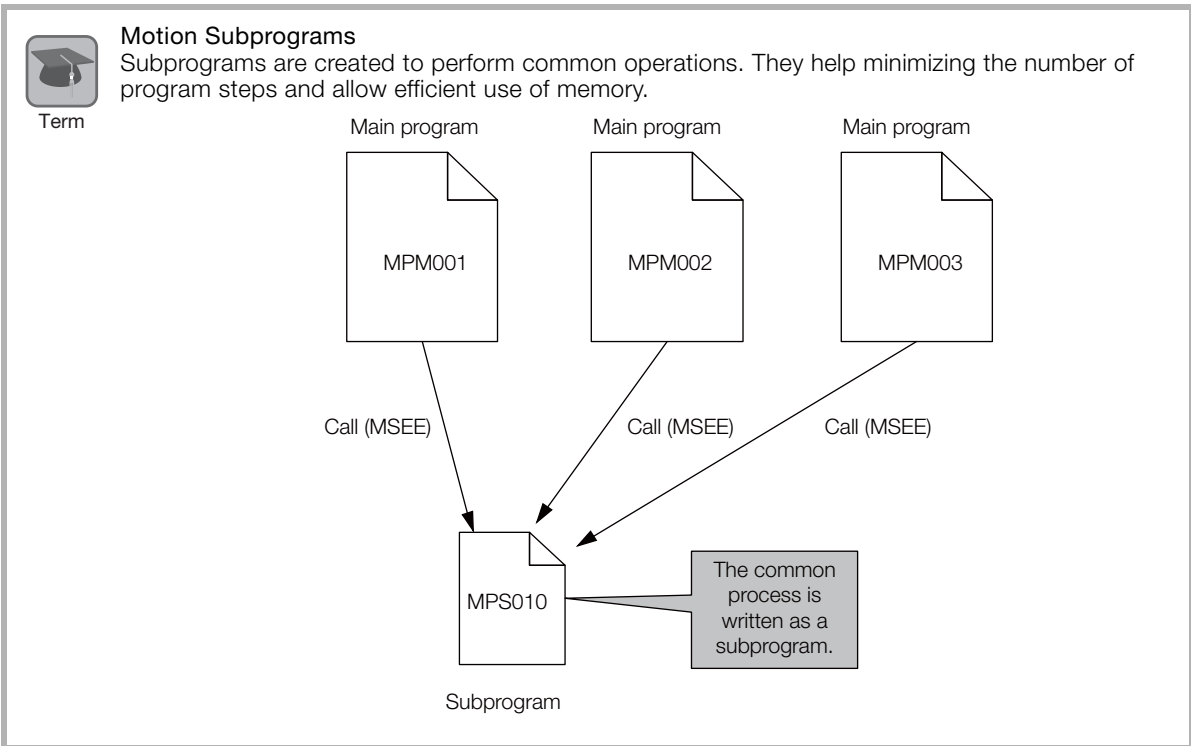

■ Motion Program Execution

Motion programs are called with an MSEE instruction from a ladder program in an H drawing.

Information You can also register the motion program in the M-EXECUTOR (Motion Executor) to call it. Refer to the following section for details.
 3.2.4 The M-EXECUTOR on page 3-53

After you create the motion program, place a Call Motion Program (MSEE) instruction in the ladder program of an H drawing. Motion programs can be called from any H drawing, regardless of whether it is a parent, child, or grandchild drawing.

The following figure shows an execution example.

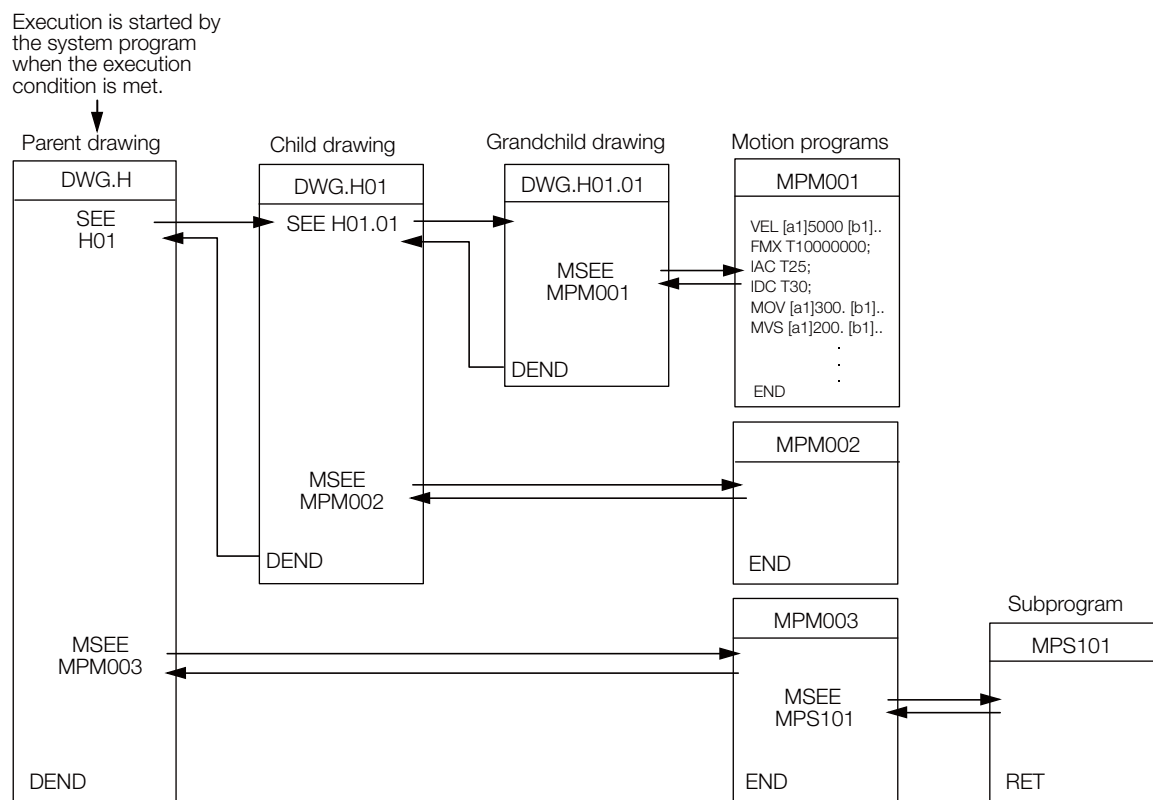

The ladder instruction in the H drawing is executed every high-speed scan cycle according to the hierarchical organization of parent-child-grandchild drawings.

The above programming only prepares for execution of the motion program. The motion program is not executed when the MSEE instruction is inserted. To start the motion program after inserting the MSEE instruction, use a control signal to turn ON the Request for Start of Program Operation.

The motion program is executed in the scan cycle, but unlike ladder programs, the entire program is not executed in a single scan. Motion programs are controlled specifically by the system's motion management.



Important

The following points must be taken into consideration when executing motion programs.

- Motion programs that are registered in the M-EXECUTOR cannot be executed with MSEE instructions.
- More than one instance of the same motion program (i.e., the same program number) cannot be executed with MSEE instructions.
- Subprograms (MPS□□□) cannot be executed with MSEE instructions in a ladder program. You can call subprograms only from motion programs and motion subprograms (MPM□□□ and MPS□□□).
- You cannot call the same subprogram more than once at the same time.
- Sequence programs (SPM□□□ or SPS□□□) cannot be called with MSEE instructions from a ladder program.

■ Specifying Motion Programs

There are two methods that you can use to specify motion programs.

- Calling the motion program by specifying it directly
- Calling the motion program by specifying it indirectly

These two methods are described below.

• Calling the Motion Program by Specifying It Directly

Direct designation is used to call a motion program by specifying its program number (MPM□□□) directly.

To call the motion program from a ladder program with the MSEE instruction, specify the program number in the Program Number operand of the MSEE instruction.

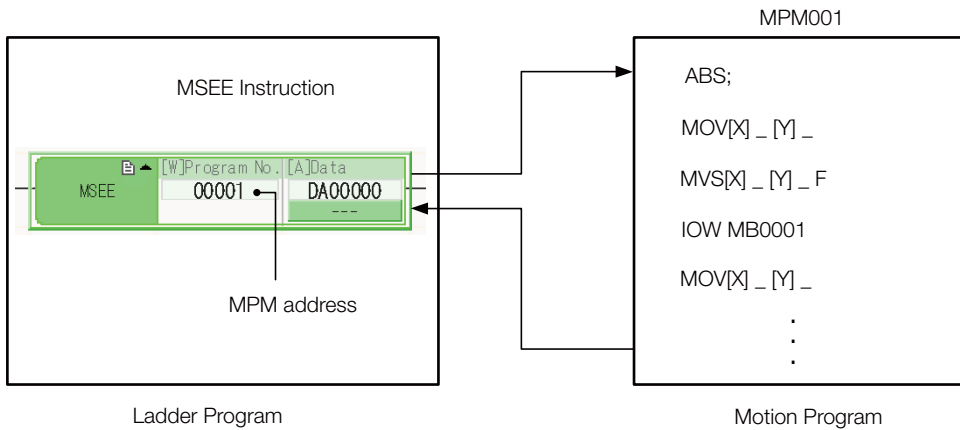

• Calling the Motion Program by Specifying It Indirectly

Indirect designation is used to call a motion program by specifying its number in a register.

In this method, the program (MPM□□□) whose number is the same as the value that is stored in the register is called.

To call the motion program from a ladder program with an MSEE instruction, use the Program Number operand of the MSEE instruction to specify the M or D register that indirectly designates the motion program.

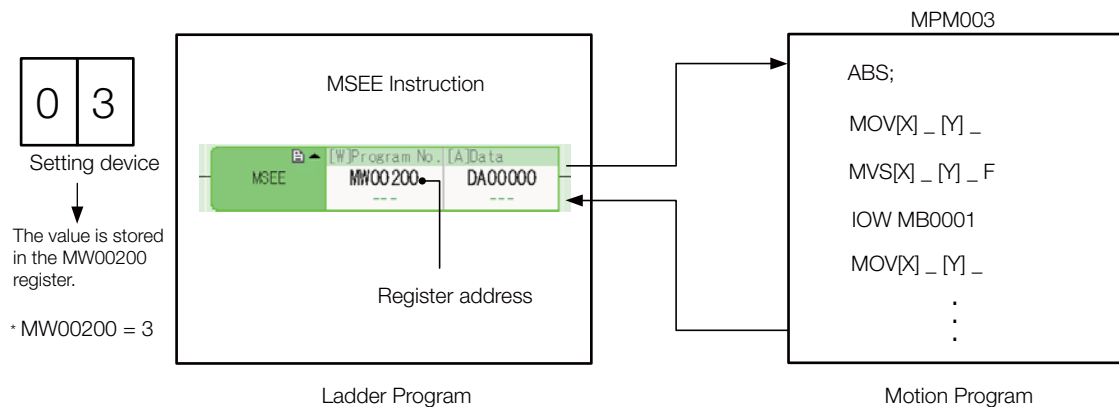

■ Work Registers

Work registers are used to set and monitor motion programs.

The address of the first work register for the motion program that is called with an MSEE instruction is specified in the MSEE instruction in the ladder program. The following figure shows the structure of the work registers.

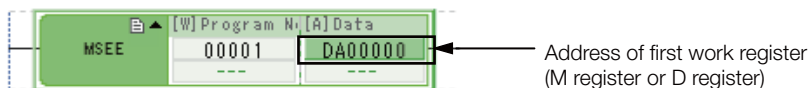

Work Register	Contents	Reference
1st register	Motion Program Status Flags	Page 3-9
2nd register	Motion Program Control Signals	Page 3-10
3rd register	Interpolation Override	Page 3-13
4th register	System Work Number	Page 3-13

• Status Flags

The Motion Program Status Flags give the execution condition of the motion program. The following table describes the meanings of the Status Flags.

Bit No.	Name	Description
Bit 0	Program Executing	This bit is set to 1 when a motion program is running. 0: Motion program is stopped. 1: Motion program is running.
Bit 1	Program Paused	This bit is set to 1 when execution of a motion program is paused by a Request for Pause of Program. After a Request for Pause of Program control signal is input, it is confirmed that the axis decelerated to a stop and then the status flag is turned ON. 0: Program is not stopped by a pause request. 1: Program is stopped by a pause request.
Bit 2	Program Stopped for Stop Request	This bit is set to 1 when execution of a motion program is stopped by a Request for Stop of Program. 0: Program is not stopped by a stop request. 1: Program is stopped by a stop request.
Bit 3	Reserved for system.	–
Bit 4	Program Single-block Execution Stopped	This bit is set to 1 when execution of a single block is stopped in Debug Operation Mode. 0: Single block execution is not stopped. 1: Single block execution is stopped.
Bit 5	Reserved for system.	–
Bit 6	Reserved for system.	–
Bit 7	Reserved for system.	–
Bit 8	Program Alarm	This bit is set to 1 when a program alarm occurs. When this bit is set to 1, details on the error will be displayed in the Error Information Dialog Box and are given in the S registers. 0: There is no program alarm. 1: A program alarm occurred.
Bit 9	Program Stopped at Breakpoint	This bit is set to 1 when execution of a program stops at a breakpoint in Debug Operation Mode. 0: Not stopped at a breakpoint. 1: Stopped at a breakpoint.
Bit A	Reserved for system.	–
Bit B	Debug Operation Mode	This bit is set to 1 when a program is running in Debug Operation Mode. 0: Not in Debug Operation Mode (Normal Execution Mode). 1: In Debug Operation Mode.
Bit C	Program Type	This bit reports whether the program that is being executed is a motion program or a sequence program. 0: Motion program 1: Sequence program

Continued on next page.

Continued from previous page.

Bit No.	Name	Description
Bit D	Start Request History	This bit is set to 1 when the Request for Start of Program Operation is ON. 0: Request for Start of Program Operation is OFF. 1: Request for Start of Program Operation is ON.
Bit E	No System Work Error or Execution Scan Error	This bit is set to 1 when a system work number that was needed to execute a motion program could not be obtained, or when an MSEE instruction is programmed in a drawing other than a DWG.H. 0: There is no system work error or execution scan error. 1: A no system work error or execution scan error occurred.
Bit F	Main Program Number Limit Exceeded Error	This bit is set to 1 when the specified motion program number is out of range. Motion program number range:1 to 512 0: There is no motion program number error. 1: A motion program number error occurred.







Note: If a program alarm occurs, motion program error information is provided in the Error Information Dialog Box and given in the S registers.

• Control Signals

To control the execution of a motion program, you must input program control signals (Request for Start of Program Operation, or Request for Stop of Program, etc.). The following table describes the control signals for motion programs.

: This mark indicates that the signal must be kept ON until the system acknowledges it.

: This mark indicates that the signal needs to be turned ON only for one high-speed scan.

Bit No.	Name	Description
Bit 0 	Request for Start of Program Operation	This bit makes a request to start execution of a motion program. The motion program starts when this bit changes from 0 to 1. This bit is ignored when there is a motion program alarm. 0: Turn OFF the request to start the program. 1: Turn ON the request to start the program.
Bit 1 	Request for Pause of Program	This bit makes a request to pause execution of a motion program. Execution of the program that was paused will resume when the pause request is turned OFF. 0: Turn OFF the request to pause the program (i.e., cancel the pause). 1: Turn ON the request to pause the program.
Bit 2 	Request for Stop of Program	This bit makes a request to stop execution of a motion program. A motion program alarm occurs if this bit is set to 1 while the axis is in motion. 0: Turn OFF the request to stop the program. 1: Turn ON the request to stop the program.
Bit 3 	Program Single-block Mode Selection	This bit makes a request to select Program Single-block Execution Mode. This mode can be used in place of Debug Operation Mode. 0: Turn OFF the request to select single-block mode. 1: Turn ON the request to select single-block mode.
Bit 4 	Program Single-block Start Request	When this bit is changed from 0 to 1, program execution changes to single-block execution (step execution). This bit is valid only when bit 3 (Program Single-block Mode Selection) in the control signals is set to 1. 0: Turn OFF the request to start the program in single-block mode. 1: Turn ON the request to start the program in single-block mode.
Bit 5 	Program Reset and Alarm Reset Request	This bit resets motion programs and alarms. 0: Turn OFF the request to reset the program and alarms. 1: Turn ON the request to reset the program and alarms.
Bit 6 	Request for Start of Continuous Program Operation	This bit makes a request to resume execution of a program that was stopped by a Request for Stop of Program. 0: Turn OFF the request to resume the program. 1: Turn ON the request to resume the program.
Bit 7	Reserved for system.	-

Continued on next page.

Continued from previous page.

Bit No.	Name	Description
Bit 8 — —	Skip 1 Information	If this bit changes to 1 while an axis is in motion due to a SKP instruction (when the skip input signal selection is set to SS1), the axis will decelerate to a stop, and the reference in the remaining travel distance will be canceled. 0: Turn OFF the skip 1 signal. 1: Turn ON the skip 1 signal.
Bit 9 — —	Skip 2 Information	If this bit changes to 1 while an axis is in motion due to a SKP instruction (when the skip input signal selection is set to SS2), the axis will decelerate to a stop, and the reference in the remaining travel distance will be canceled. 0: Turn OFF the skip 2 signal. 1: Turn ON the skip 2 signal.
Bit A, B	Reserved for system.	—
Bit C	Reserved for system.	—
Bit D — —	System Work Number Setting*1	To specify a system work number, set this bit to 1. 0: Do not specify a system work number. 1: Specify a system work number.
Bit E — —	Interpolation Override Setting*2	To specify an interpolation override, set this bit to 1. 0: Do not specify an interpolation override. 1: Specify an interpolation override.
Bit F	Reserved for system.	—

*1. System Work Number Setting

- When the Motion Program Is Registered in M-EXECUTOR:
The system work number cannot be specified. The system will use the definition number as the system work number.
- When a Motion Program Is Called from a Ladder Program with an MSEE Instruction:
- OFF: The system will use an automatically acquired system work number. The system work number will be different each time.
- ON: The work number that is specified by the system will be used.
- However, if the work number is assigned to the M-EXECUTOR, a No System Work Available Error (Status Flag Bit E) is reported.

*2. Interpolation Override Setting

- OFF: The interpolation override is always 100%.
- ON: The interpolation override in the parameter setting is used.

Note: 1. Use the specified signal types for the ladder program inputs.

2. At startup, the motion programs for which the Request for Start of Program Operation control signals are ON will be executed.

Example Timing chart examples for axis operations and status flags after a control signal is input are provided below.

Request for Start of Program Operation

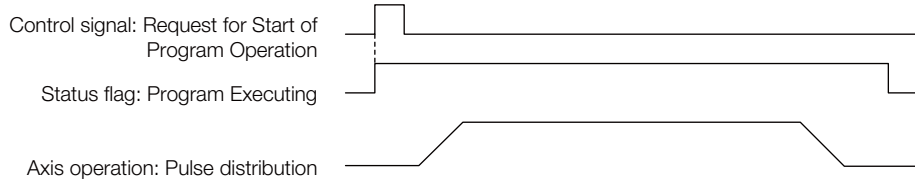

Request for Pause

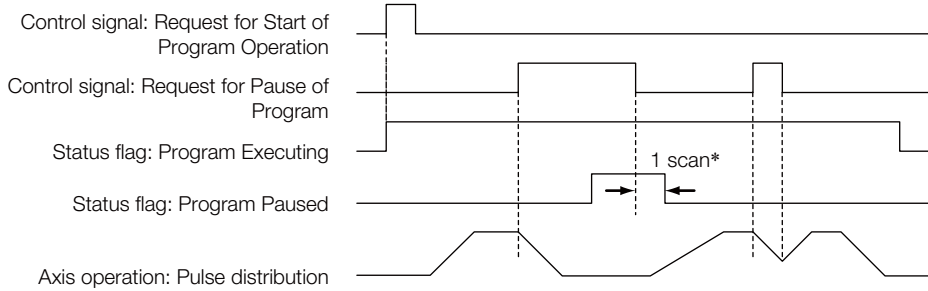

* Status flags related to control signal input are updated after one scan.

Request for Stop

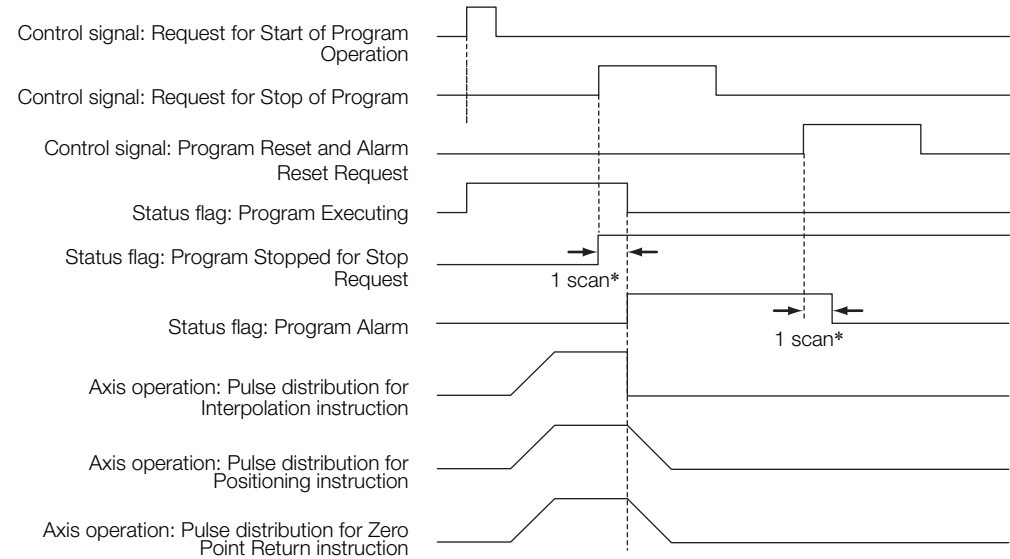

* Status flags related to control signal input are updated after one scan.

If a Motion Program Alarm Occurs

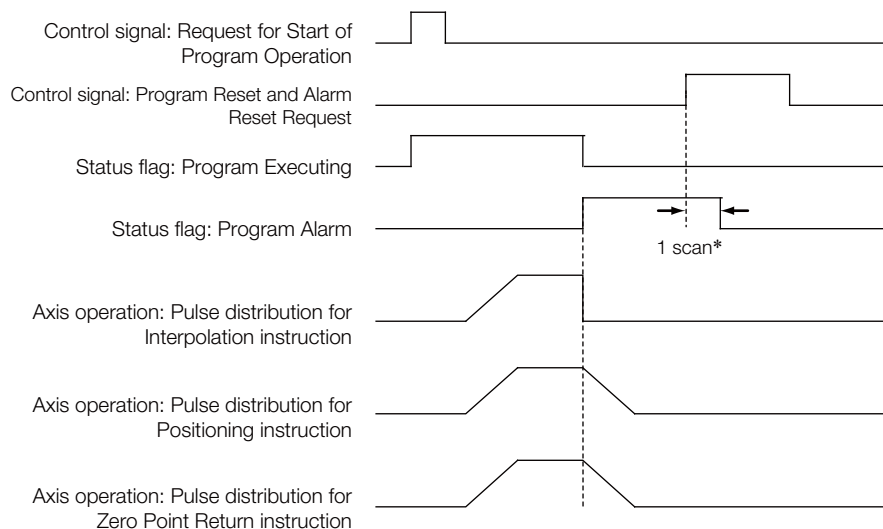

* Status flags related to control signal input are updated after one scan.



Important

1. If the Request for Stop of Program control signal is turned ON while the axis is being controlled for a motion language instruction, an alarm will occur.
2. If the Request for Stop of Program control signal is turned ON while the axis is being controlled for an interpolation motion language instruction, the axes will stop immediately. To perform a deceleration stop, use the Request for Pause of Operation control signal.
3. The Request for Pause of Program control signal is not acknowledged while a Zero Point Return (ZRN) instruction is being executed. To stop the operation, use the Request for Stop of Program control signal.
4. If a motion program alarm occurs while an axis is in motion, the axis stops immediately.

Refer to the following manuals for details on programming examples for controlling motion programs.

📖 MP3000 Series Motion Programming Manual (Manual No.: SIEP C880725 14)

• Interpolation Override

An interpolation override allows you to change the output ratio of the axis movement speed reference for interpolation motion language instructions.

Set the override value to use when executing interpolation instructions (MVS, MCW, MCC, or SKP).

The interpolation override is valid only when bit E (Interpolation Override Setting) in the control signals is ON.

The setting range of the interpolation override is 0 to 32,767.

Unit: 1 = 0.01%

• System Work Numbers

When you call a motion program from a ladder program with the MSEE instruction, set the system work number to use to call the motion program. This system work number is valid only when bit D (System Work Number Setting) of the control signals is ON.

Setting range: 1 to 32



Important

When using MSEE instructions in ladder programs along with the M-EXECUTOR, do not specify the system work numbers that are for the M-EXECUTOR in the MSEE instructions in the ladder programs. If you specify one, a No System Work Error will occur.
System work numbers for the M-EXECUTOR: 0 to the set value of the number of program definitions

Information You cannot set the system work numbers when you use the M-EXECUTOR. The system will use system work numbers that are the same as the definition numbers.

■ Monitoring Motion Program Execution Information

The execution information for motion programs can be monitored using the S registers (SW03200 to SW05119 and SW08192 to SW09125).

The execution information is monitored differently, depending on whether the motion program is called from a ladder program with an MSEE instruction, or the motion program is registered in the M-EXECUTOR program execution definitions.

This section describes these two monitoring methods.

• When the Motion Program Is Called from the Ladder Program with an MSEE Instruction

When a motion program is called from the ladder program with an MSEE instruction, the monitoring method depends on the setting of bit D (System Work Number Setting) in the Motion Program Control Signals.

Bit D (System Work Number Setting) in the Control Signal Word for Motion Programs	Monitoring
ON	The execution information is reported in the Work n Program Information registers (SW03264 to SW05119 and SW08192 to SW09125). For example, if the system work number is 1, you can monitor the execution information of the motion program with the Work 1 Program Information registers (SW03264 to SW03321).
OFF	The system automatically determines the system work number to use. You can check the work numbers that are in use in the Active Program Numbers registers (SW03200 to SW03231). For example, if MPM001 is the motion program to be monitored and SW03202 contains a 1, the system work number is 3. You can therefore monitor the execution information of the motion program with the Work 3 Program Information registers (SW03380 to SW03437).

• When the Motion Program Is Registered in the M-EXECUTOR Program Execution Definitions:

When the motion program is registered in the M-EXECUTOR program execution definitions, the system work number used will be the same as the program execution registration number in the M-EXECUTOR.

For example, if the motion program is registered for execution as number 3, system work number 3 is used. You can therefore monitor the execution information of the motion program with the Work 3 Program Information registers (SW03380 to SW03437).

◆ Sequence Programs

A sequence program is written in a text-based motion language.

There are two types of sequence programs.

Type	Designation Method	Features	Number of Programs
Main programs	SPM□□□ (□□□=1 to 512)	Main programs are called from the M-EXECUTOR program execution definitions.	You can create up to 512 motion programs, including the following programs: <ul style="list-style-type: none"> • Motion main programs • Motion subprograms • Sequence main programs • Sequence subprograms
Subprograms	SPS□□□ (□□□=1 to 512)	Subprograms are called from a main program.	



Important

The same numbers are used to manage the sequence programs and motion programs.

Use a unique number for each program.

- Motion program numbers are given in the form MPM□□□□ or MPS□□□□.
- Sequence program numbers are given in the form SPM□□□□ or SPS□□□□.

■ Sequence Program Execution

A sequence program is executed by registering it in the M-EXECUTOR execution definitions.

The sequence programs are executed in ascending order.

The following figure shows an execution example.

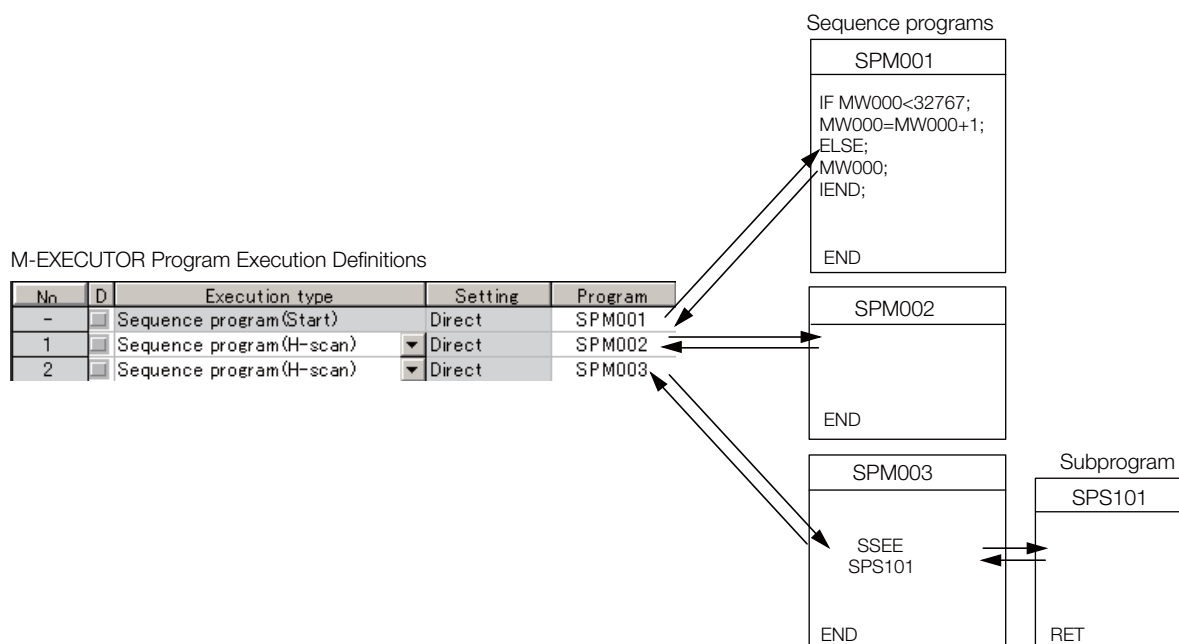

If the execution type is set to an H-scan sequence program or L-scan sequence program, then the program will be executed as soon as the definition is saved. If the execution type is set to a startup sequence program, then the program will be executed the next time when the power supply is turned ON.

■ Specifying Sequence Programs

Sequence programs must be specified directly. Indirect designations cannot be used. Specify the program number of the sequence program to execute (SPM□□□).

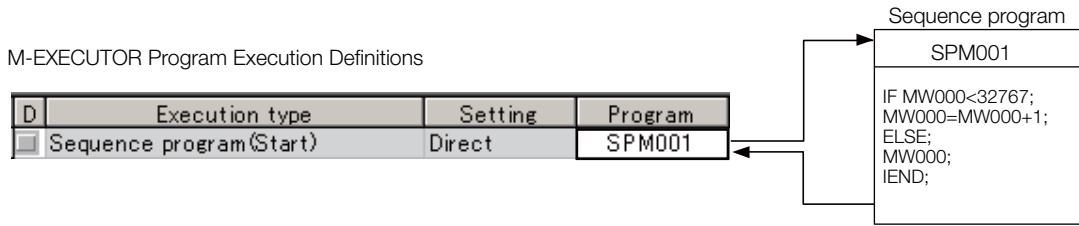

■ Work Registers

Work registers are used to monitor sequence programs.

The work registers have Status Flags inside the M-EXECUTOR control registers, in the same way as motion programs that are registered in the M-EXECUTOR.

• Sequence Program Status Flags

The Sequence Program Status Flags give the execution condition of the sequence program.

The following table describes the meanings of the Status Flags.

Bit No.	Status
0	Program is being executed.
1	Reserved for system.
2	Reserved for system.
3	Reserved for system.
4	Reserved for system.
5	Reserved for system.
6	Reserved for system.
7	Reserved for system.
8	There is a program alarm.
9	Execution is stopped at a breakpoint.
A	Reserved for system.
B	The program is in Debug Mode (EWS debugging).
C	Program Type, 1: Sequence program
D	There is a request to start program execution.
E	Reserved for system.
F	Reserved for system.



Important

Sequence Program Alarms

When an error is detected, bit 8 (Program Alarm) turns ON in the Status Flags in the M-EXECUTOR control registers.

When the error is removed, this bit turns OFF.

The following errors can occur.

- The called program is not registered.
- The called program is not a sequence program.
- The called program is not a subprogram (a main program was called).
- Called Program Number Limit Exceeded Error
- Too Many Nesting Levels Error

3.1.2 Registers

Registers are areas that store data within the Machine Controller. Variables are registers with labels (variable names).

There are two kinds of registers: global registers that are shared between all programs, and local registers that are used only by a specific program.

Global Registers

Global registers are shared by ladder programs, user functions, motion programs, and sequence programs. Memory space for global registers is reserved by the system for each register type.

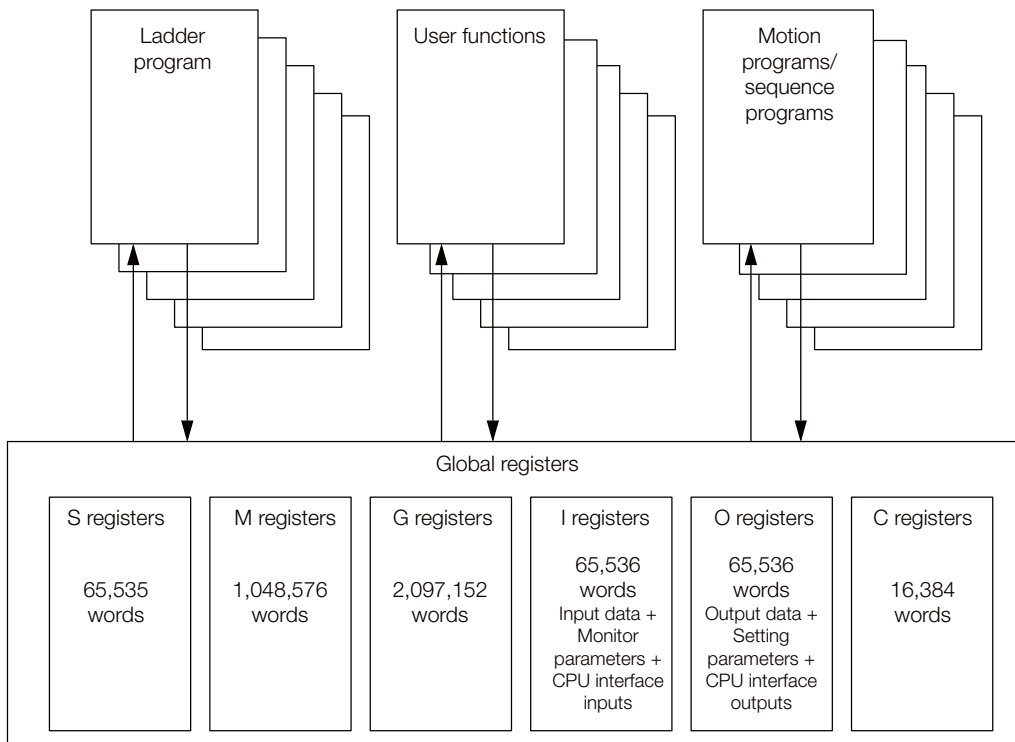

Local Registers

Local registers can be used within each specific drawing. These registers cannot be shared by other drawings. Local registers are stored in the program memory for each drawing.

Ladder Program Conceptual Diagram

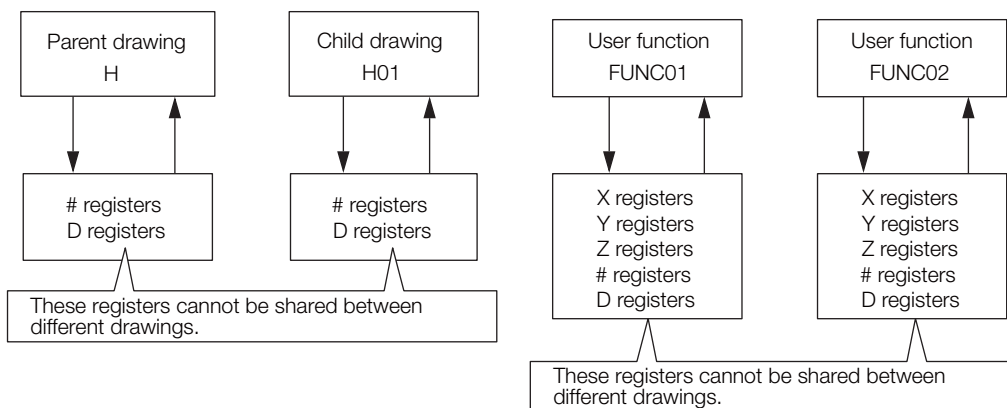

Motion Program Conceptual Diagram

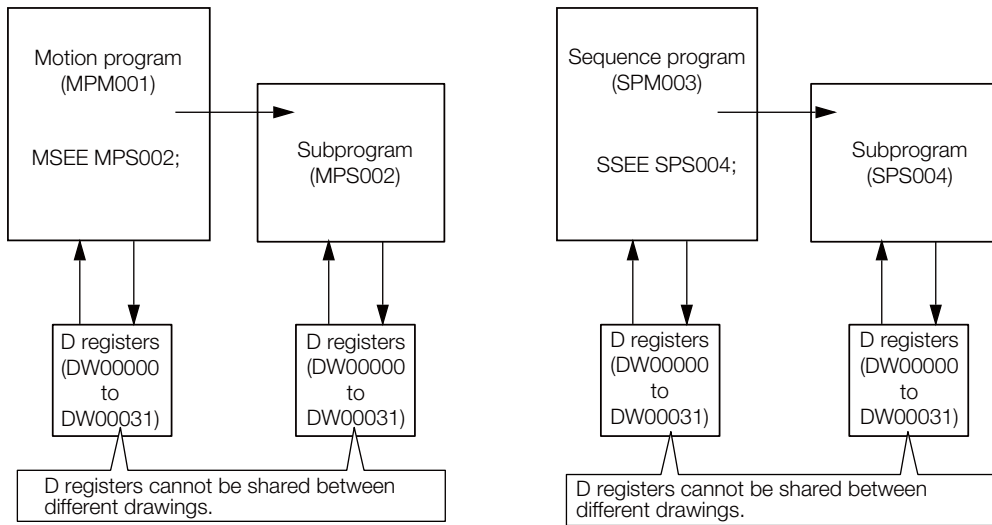

Structure of Register Addresses

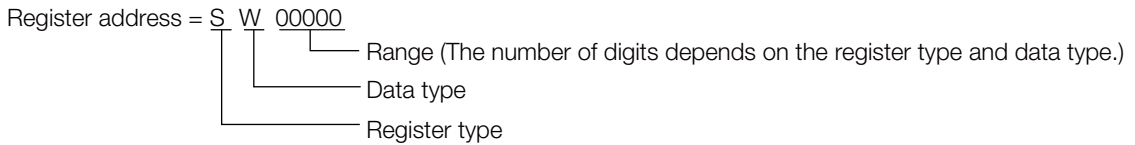

Information

You can also use index registers or array registers as variables to address specific registers. Refer to the following sections for details.

Index Registers (i, j) on page 3-25

Array Registers (I) on page 3-27

Register Types

This section describes global and local registers.

◆ Global Registers

Global registers are shared by ladder programs, user functions, motion programs, and sequence programs. In other words, the operation results of a ladder program can be used by other user functions, motion programs, or sequence programs.

Type	Name	Designation Method	Usable Range	Description
S	System registers (S registers)	SBnnnnnh, SWnnnnn, SLnnnnn, SQnnnnn, SFnnnnn, SDnnnnn, SAnnnnn	SW00000 to SW65534	These registers are prepared by the system. They report the status of the Machine Controller and other information. The system clears the registers from SW00000 to SW00049 to 0 at startup. They have a battery backup.
M	Data registers (M registers)	MBnnnnnnnh, MWnnnnnnn, MLnnnnnnn, MQnnnnnnn, MFnnnnnnn, MDnnnnnnn, MAnnnnnnn	MW0000000 to MW1048575	These registers are used as interfaces between programs. They have a battery backup.

Continued on next page.

Continued from previous page.

Type	Name	Designation Method	Usable Range	Description
G	G registers	GBnnnnnnh, GWnnnnnn, GLnnnnnn, GQnnnnnn, GFnnnnnn, GDnnnnnn, GAnnnnn	GW000000 to GW2097151	These registers are used as interfaces between programs. They do not have a battery backup.
I	Input registers (I registers)	IBhhhhh, IWhhhhh, ILhhhhh, IQhhhhh, IFhhhhh, IDhhhhh, IAhhhhh	IW00000 to IW07FFF, IW10000 to IW17FFF	These registers are used for input data.
			IW08000 to IW0FFFF	These registers store the motion monitor parameters. These registers are used for Motion Modules.
			IW20000 to IW21FFF	These registers are used as interfaces between the CPU Modules when Expansion Racks are used (CPU interface registers).
O	Output registers (O registers)	OBhhhhh, OWhhhhh, OLhhhhh, OQhhhhh, OFhhhhh, ODhhhhh, OAhhhhh	OW00000 to OW07FFF, OW10000 to OW17FFF	These registers are used for output data.
			OW08000 to OW0FFFF	These store the motion setting parameters. These registers are used for Motion Modules.
			OW20000 to OW21FFF	These registers are used as interfaces between the CPU Modules when Expansion Racks are used (CPU interface registers).
C	Constant registers (C registers)	CBnnnnnh, CWnnnnn, CLnnnnn, CQnnnnn, CFnnnnn, CDnnnnn, CAnnnnn	CW00000 to CW16383	These registers can be read in programs but they cannot be written. The values are set from the MPE720.

Note: n: decimal digit, h: hexadecimal digit

◆ Local Registers

Local registers are valid within only one specific program. The local registers in other programs cannot be accessed.

You specify the usable range from the MPE720.

Type	Name	Designation Method	Description	Features
#	# registers	#Bnnnnnh, #Wnnnnn, #Lnnnnn, #Qnnnnn, #Fnnnnn, #Dnnnnn, #Annnnn	These registers can be read in programs but they cannot be written. The values are set from the MPE720.	Program-specific
D	D registers	DBnnnnnh, DWnnnnn, DLnnnnn, DQnnnnn, DFnnnnn, DDnnnnn, DAnnnnn	These registers can be used for general purposes within a program. By default, 32 words are reserved for each program. The default value after startup depends on the setting of the D Register Clear when Start option. Refer to the following section for details.  • <i>Setting the D Register Clear When Start Option on page 3-21</i>	

Continued on next page.

Continued from previous page.

Type	Name	Designation Method	Description	Features
X	Function input registers	XBnnnnnh, XWnnnnn, XLnnnnn, XQnnnnn, XFnnnnn, XDnnnnn	These registers are used for inputs to functions. <ul style="list-style-type: none"> • Bit inputs: XB000000 to XB00000F • Integer inputs: XW00001 to XW00016 • Double-length integers: XL00001 to XL00015 • Quadruple-length integers: XQ00001 to XQ00013 • Real numbers: XF00001 to XF00015 • Double-precision real numbers: XD00001 to XD00013 	Function-specific
Y	Function output registers	YBnnnnnh, YWnnnnn, YLnnnnn, YQnnnnn, YFnnnnn, YDnnnnn	These registers are used for outputs from functions. <ul style="list-style-type: none"> • Bit outputs: YB000000 to YB00000F • Integer outputs: YW00001 to YW00016 • Double-length integers: YL00001 to YL00015 • Quadruple-length integers: YQ00001 to YQ00013 • Real numbers: YF00001 to YF00015 • Double-precision real numbers: YD00001 to YD00013 	
Z	Function internal registers	ZBnnnnnh, ZWnnnnn, ZLnnnnn, ZQnnnnn, ZFnnnnn, ZDnnnnn	These are internal registers that are unique within each function. You can use them for internal processing in functions. <ul style="list-style-type: none"> • Bits: ZB000000 to ZB00063F • Integers: ZW00000 to ZW00063 • Double-length integers: ZL00000 to ZL00062 • Quadruple-length integers: ZQ00000 to ZQ00060 • Real numbers: ZF00000 to ZF00062 • Double-precision real numbers: ZD00000 to ZD00060 	
A	Function external registers	ABnnnnnh, AWnnnnn, ALnnnnn, AQnnnnn, AFnnnnn, ADnnnnn	These are external registers that use the address input value as the base address. When the address input value of an M or D register is provided by the source of the function call, then the registers of the source of the function call can be accessed from inside the function by using that address as the base.	

Note: n: decimal digit, h: hexadecimal digit



Important User functions can be called from any programs, any number of times.

■ Precautions When Using Local Registers within a User Function

When you call a user function, consider what values could be in the local registers, and perform initialization as needed.

Name	Precautions
X registers (function input registers)	If input values are not set, the values will be uncertain. Do not use X registers that are outside of the range that is specified in the input definitions.
Y registers (function output registers)	If output values are not set, the values will be uncertain. Always set the values of the range of Y registers that is specified in the output definitions.
Z registers (function internal registers)	When the function is called, the previously set values will be lost and the values will be uncertain. These registers are not appropriate for instructions if the previous value must be retained. Use them only after initializing them within the function.
# registers	These are constant registers. Their values cannot be changed.

Continued on next page.

Continued from previous page.

Name	Precautions
D registers	<p>When the function is called, the previously set values are preserved. If a previous value is not necessary, initialize the value, or use a Z register instead. D registers retain the data until the power is turned OFF. The default value after startup depends on the setting of the D Register Clear when Start option. Refer to the following sections for details.</p> <p> • <i>Setting the D Register Clear When Start Option</i> on page 3-21</p>

- Setting the D Register Clear When Start Option

1. Select **File – Environment Setting** from the MPE720 Version 7 Window.
2. Select **Setup – System Setting**.
3. Select **Enable** or **Disable** for the **D Register Clear when Start** option.
 Disable: The initial values will be uncertain.
 Enable: The initial values will be 0.

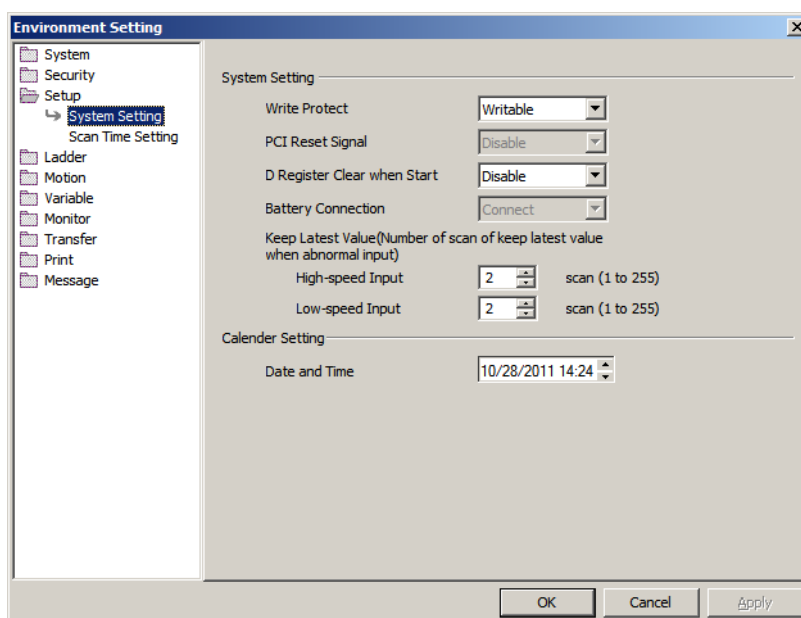

Data Types

There are various data types that you can use depending on the purpose of the application: bit, integer, double-length integer, quadruple-length integer, real number, double-precision real number, and address.

Symbol	Data Type	Range of Values	Data Size	Description
B	Bit	1 (ON) or 0 (OFF)	–	Used in relay circuits and to determine ON/OFF status.
W	Integer	-32,768 to 32,767 (8000 to 7FFF hex)	1 word	Used for numeric operations. The values in parentheses on the left are for logical operations.
L	Double-length integer	-2,147,483,648 to 2,147,483,647 (80000000 to 7FFFFFFF hex)	2 words	Used for numeric operations. The values in parentheses on the left are for logical operations.
Q	Quadruple-length integer*1	-9,223,372,036,854,775,808 to 9,223,372,036,854,775,807 (8000000000000000 to 7FFFFFFFFFFFFFFF hex)	4 words	Used for numeric operations. The values in parentheses on the left are for logical operations.

Continued on next page.

3.1 Basic Functionality

3.1.2 Registers

Continued from previous page.

Symbol	Data Type	Range of Values	Data Size	Description
F	Real number	$\pm (1.175E - 38 \text{ to } 3.402E + 38)$ or 0	2 words	Used for advanced numeric operations.*2
D	Double-precision real number*1	$\pm (2.225E - 308 \text{ to } 1.798E + 308)$ or 0	4 words	Used for advanced numeric operations.*2
A	Address	0 to 2,097,152	-	Used only as pointers for addressing.

*1. These data types cannot be used for indirect designation of motion programs.

*2. Conforms to IEEE754 standards.



Important

The MP3000-series Machine Controller does not have separate registers for each data type. As shown in the following figure, the same address will access the same register even if the data type is different. For example, MB00001003, a bit address, and the MW0000100, an integer address, have different data types, but they both access the same register, MW0000100.

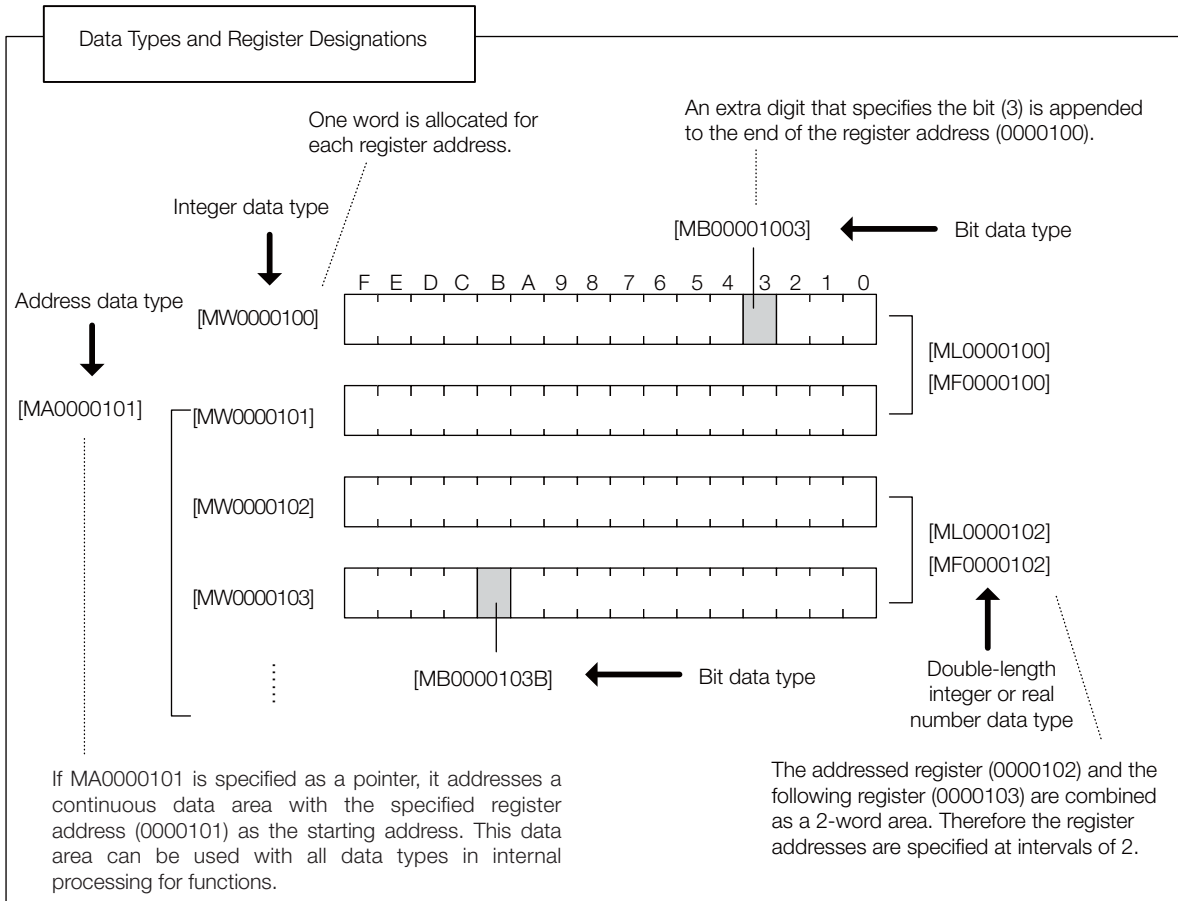



Term

Pointer Designation

When an address is passed to a function as a parameter, this is referred to as pointer designation. When pointer designation is used, the continuous data area starting from the address of the specified register address can be used in internal processing for functions with all data types.

◆ Precautions for Operations Using Different Data Types

If you perform an operation using different data types, be aware that the results will be different depending on the data type of the storage register, as described below.

• Storing Real Number Data in an Integer Register

MW0000100 = MF0000200; the real number is stored after it is converted to an integer.
(00001) (1.234)

Note: There may be rounding error due to storing a real number in an integer register.

Whether numbers are rounded or truncated when converting a real number to an integer can be set in the properties of the drawing.

 ■ *Setting for Real Number Casting* on page 3-23

MW0000100 = MF0000200 + MF0000202; The result of the operation may be different depending on the value of the variable.
(0124) (123.48) (0.02)
(0123) (123.49) (0.01)

• Storing Real Number Data in a Double-length Integer Register

ML0000100 = MF0000200; the real number is stored after it is converted to an integer.
(65432) (65432.1)

• Storing Double-length Integer Data in an Integer Register

MW0000100 = ML0000200; the lower 16 bits of the double-length integer are stored without change.
(-00001) (65535)

• Storing Integer Data in a Double-length Integer Register

ML0000100 = MW0000200; the integer is stored after it is converted to double-length integer data.
(0001234) (1234)

■ Setting for Real Number Casting

The casting method (truncating or rounding) can be set in the detailed definitions in the Drawing Properties Dialog Box. The method to use for real number casting is set for each drawing.

Use the following procedure to display the Program Property Dialog Box.

1. In the Ladder Pane, select the ladder program for which to view the properties.
2. Right-click the selected program and select **Property** from the pop-up menu.
The Program Property Dialog Box will be displayed.

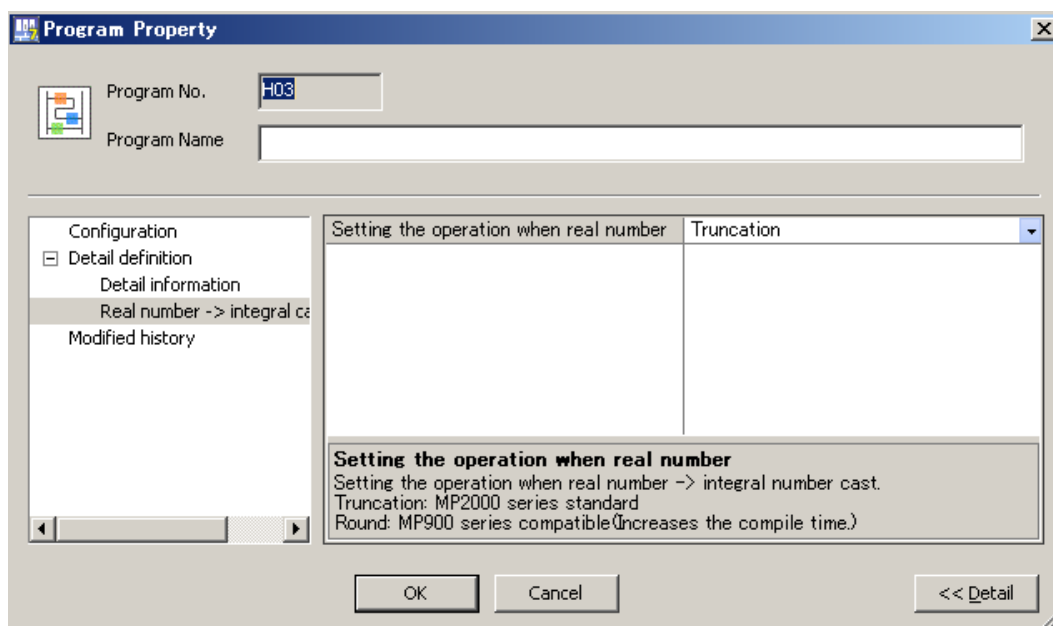

3.1 Basic Functionality

3.1.2 Registers

Information

The data is little endian, as shown in the following example.

- MB00001006

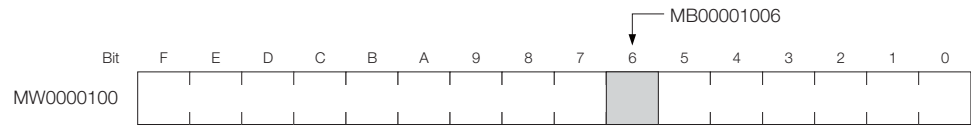

- MW0000100 = 1234 hex



- ML0000100 = 12345678 hex

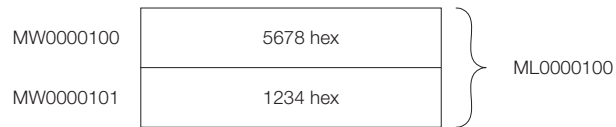

- MQ0000100 = 123456789ABCDEF0 hex



Index Registers (i, j)

There are two special registers, i and j, that are used to modify relay and register addresses. The functions of i and j are identical. They are used to handle register addresses like variables.

There are subscript registers for each program type, as shown in the following figure.

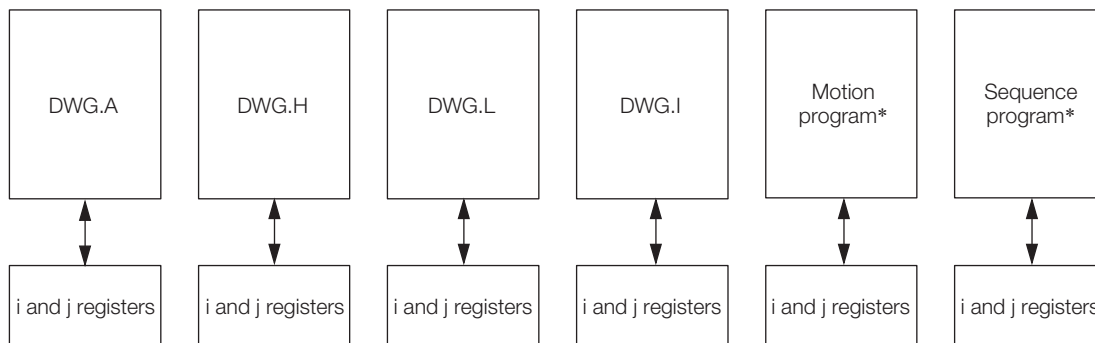

* Motion programs and sequence programs have separate i and j registers for each task.

Note: Functions reference the i and j registers that belong to the calling drawing.

For example, a function called by DWG.H will reference the i and j registers for DWG.H.

We will describe this with examples for each register data type.

◆ Attaching an Index to a Bit Register

Using an index is the same as adding the value of i or j to the register address.

For example, if $i = 2$, $MB00000000i$ is the same as $MB00000002$.

$i = 2;$
 $DB000000 = MB00000000i;$ Equivalent $DB000000 = MB00000002;$

◆ Attaching an Index to an Integer Register

Using an index is the same as adding the value of i or j to the register address.

For example, if $j = 30$, $MW0000001j$ is the same as $MW00000031$.

$j = 30;$
 $DW000000 = MW0000001j;$ Equivalent $DW000000 = MW00000031;$

◆ Attaching an Index to a Double-length Integer or a Real Number Register

Using an index is the same as adding the value of *i* or *j* to the register address.

For example, if *j* = 1, ML0000000j is the same as ML0000001. Similarly, if *j* = 1, MF0000000j is the same as MF0000001.

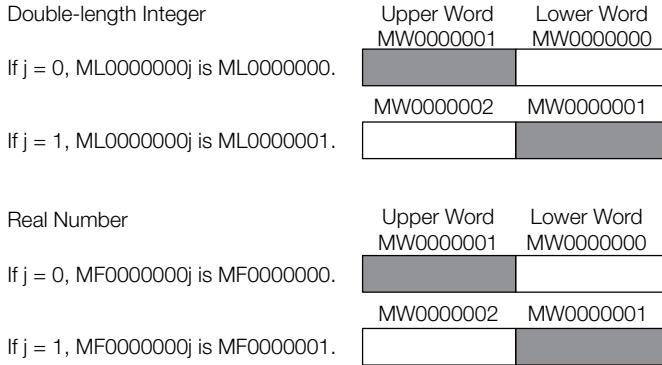



Important

Double-length integers and real numbers use a region that is 2 words in size. For example, when using ML0000000j with both *j* = 0 and *j* = 1, the one-word area of MW0000001 will overlap. Be careful of overlapping areas when indexing double-length integer or real number register addresses.

◆ Attaching an Index to a Quadruple-length Integer or a Double-precision Real Number Register

Using an index is the same as adding the value of *i* or *j* to the register address.

For example, if *j* = 2, MQ0000000j is the same as MQ0000002. Similarly, if *j* = 2, MD0000000j is the same as MD0000002.

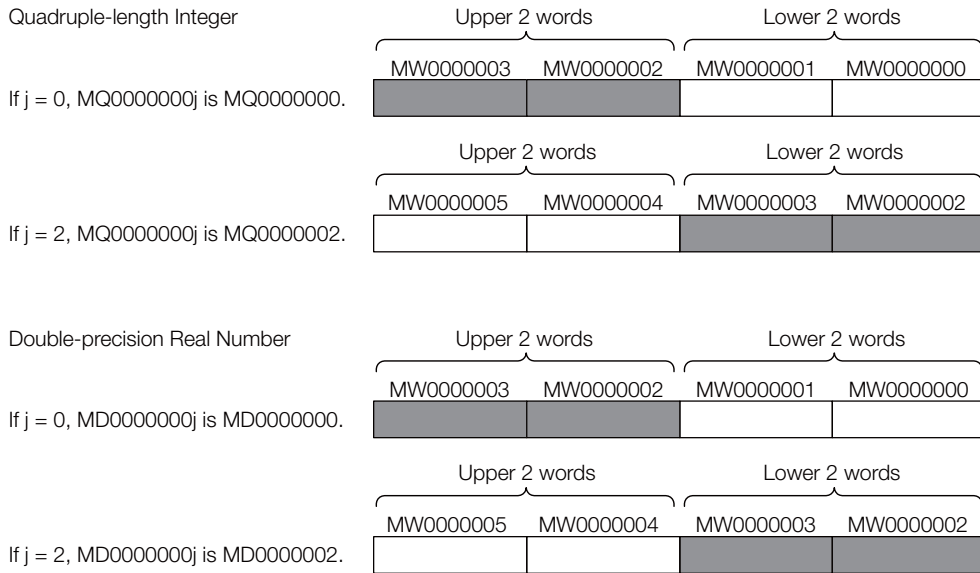



Important

Quadruple-length integers and double-precision real numbers use a region that is 4 words in size. For example, when using MQ0000000j with both *j* = 0 and *j* = 2, the two-word area of MW0000002 and MW0000003 will overlap. Be careful of overlapping areas when indexing quadruple-length integer or double-precision real number register addresses.

Array Registers ([])

Array registers are used to modify register addresses, and are denoted by square brackets [].

These are used to handle register addresses like variables.

Similarly to index registers, an offset is added to the register address.

◆ Attaching an Array Register to a Bit Register

Using an array register is the same as adding the value of the array register to the register address.

For example, if $DW00000 = 2$, $MB00000000[DW00000]$ is the same as $MB00000002$.

$DW00000 = 2;$	Equivalent	
$DB000020 = MB00000000[DW00000];$	\longleftrightarrow	$DB000020 = MB00000002;$

◆ Attaching an Array Register to a Register Other Than a Bit Register

Using an array register is the same as adding the word size of the data type of the array register times the value of the array register to the register address.

For example, if $DW00000 = 30$, $ML00000002[DW00000]$ is the same as $ML00000062$.

$DL00002 = ML00000 (30 \times 2 + 2) = ML0000062$

$DW00000 = 30;$	Equivalent	
$DL00002 = ML00000002[DW00000];$	\longleftrightarrow	$DL00002 = ML00000062;$

3.1.3 Execution Scheduling

This section describes the execution order of drawings.

Controlling the Execution of Drawings

Drawings are executed based on their priorities, as shown in the following figure.

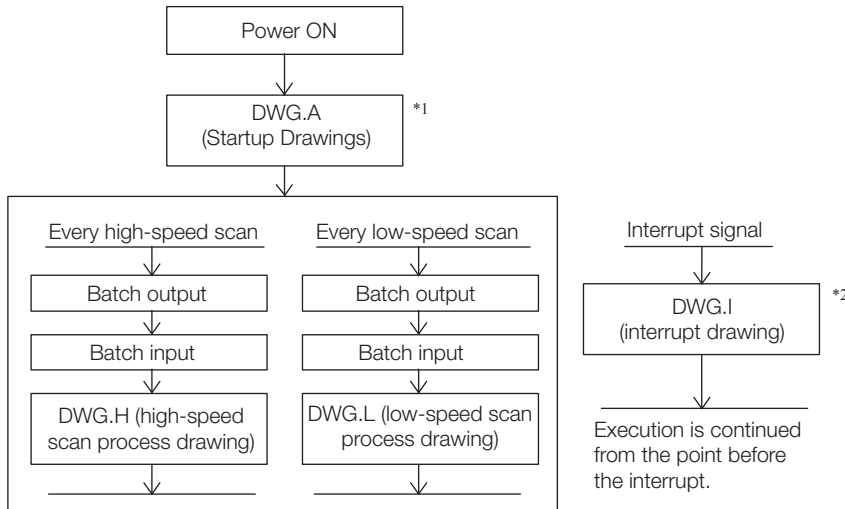

*1. DWG.A drawings are executed immediately after the power supply is turned ON.

*2. When an interrupt signal is input, execution of the DWG.I drawing is given priority even if execution of a DWG.H or DWG.L drawing is currently in progress.

Note: The parent drawing of each drawing is automatically called and executed by the system.

Scheduling the Execution of High-speed and Low-speed Scan Process Drawings

High-speed scan process drawings (DWG.H) and low-speed scan process drawings (DWG.L) cannot be executed at the same time. DWG.L drawings are executed during the idle time of DWG.H drawings.

The period during which DWG.H drawings are executed is called the high-speed scan time. The period during which DWG.L drawings are executed is called the low-speed scan time.

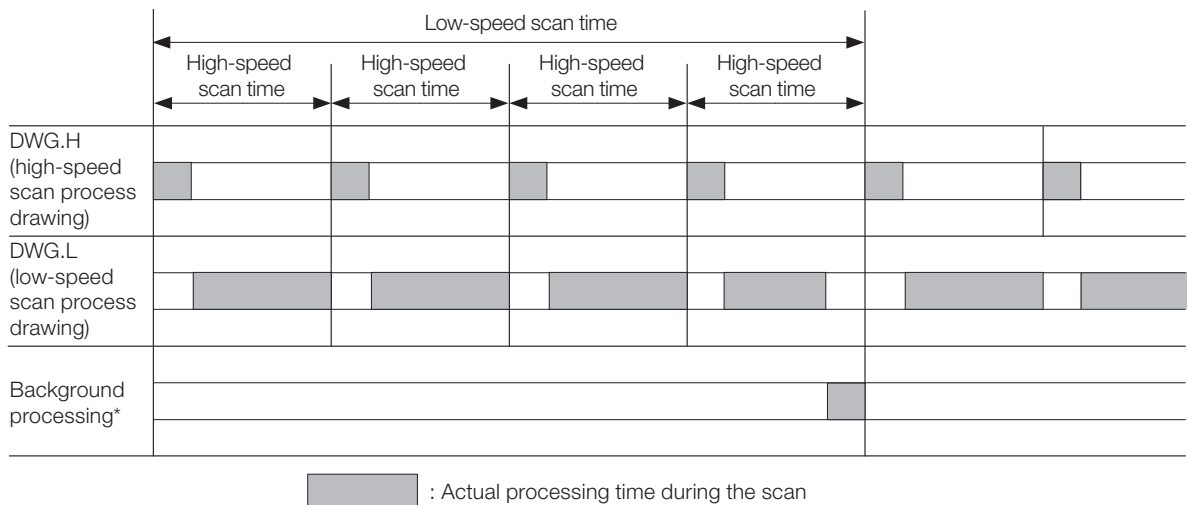

* Background processing is used to execute internal system processing, such as communications processing.

Refer to the following section for the setting procedure for the high-speed and low-speed scans.

🔧 [Setting the High-speed and Low-speed Scan Times](#) on page 3-32

3.1.4 Scans

A scan refers to the processing that starts at fixed intervals.

This section describes the scans.

Types of Scans

The CPU Modules has two types of scans, the high-speed H scan and low-speed L scan.

A high-speed H scan has higher priority than a low-speed L scan. The fixed period for each scan, also known as the scan time, can be set by the user.

This section describes the settings for the scan times.

High-speed (H) Scan

The following table shows the different high-speed scan time set values depending on whether the MP2000 Optional Module is used.



There are restrictions on the set value of the high-speed scan time. Refer to the following section for details.

 **High-speed Scan Time Set Value Restrictions** on page 3-29

Abbreviation	When the MP2000 Optional Module Is Not Used	When the MP2000 Optional Module Is Used
CPU-301	0.25 to 32.0 ms (in increments of 0.125 ms)	0.25 ms or 0.5 to 32.0 ms (in increments of 0.5 ms)
CPU-302	0.125 to 32.0 ms (in increments of 0.125 ms)	0.125 ms, 0.25 ms, or 0.5 to 32.0 ms (in increments of 0.5 ms)

Information The default high-speed scan time is 4.0 ms.

◆ High-speed Scan Time Set Value Restrictions

This section describes the restrictions on the set value of the high-speed scan time.

■ Restrictions Imposed by the MECHATROLINK-III Communications Cycle

The high-speed scan of the CPU Module is synchronized with the MECHATROLINK-III communications cycle of the SVC or SVC32 Module in the CPU Module. This imposes the following restrictions in the set value of the high-speed scan time.

Communications Cycle	High-speed Scan Time Set Value Restrictions	Possible Set Values	
		When MP2000 Optional Module Is Not Used	When MP2000 Optional Module Is Used
125 μ s	Integral multiple of 125 μ s	CPU-301	0.25 to 32.0 ms (in increments of 0.125 ms)
		CPU-302	0.125 to 32.0 ms (in increments of 0.125 ms)
250 μ s	Integral multiple of 250 μ s or 1 times the integer portion	0.250 to 32.0 ms (in increments of 0.250 ms)	0.250 ms or 0.5 to 32.0 ms (in increments of 0.5 ms)
500 μ s	Integral multiple of 500 μ s or 1 times the integer portion	0.5 to 32.0 ms (in increments of 0.5 ms)	0.5 to 32.0 ms (in increments of 0.5 ms)
1 ms	Integral multiple of 1 ms or 1 times the integer portion	1.0 to 32.0 ms (in increments of 1 ms)	1.0 to 32.0 ms (in increments of 1 ms)
1.5 ms	Integral multiple of 1.5 ms or 1 times the integer portion	1.5 to 31.5 ms (in increments of 1.5 ms)	1.5 to 31.5 ms (in increments of 1.5 ms)

Continued on next page.

Continued from previous page.

Communications Cycle	High-speed Scan Time Set Value Restrictions	Possible Set Values	
		When MP2000 Optional Module Is Not Used	When MP2000 Optional Module Is Used
2 ms	Integral multiple of 2 ms or 1 times the integer portion	2.0 to 32.0 ms (in increments of 2 ms)	2.0 to 32.0 ms (in increments of 2 ms)
3 ms	Integral multiple of 3 ms or 1 times the integer portion	3.0 to 30.0 ms (in increments of 3 ms)	3.0 to 30.0 ms (in increments of 3 ms)

If these restrictions are not observed, the high-speed scan cycle will stop and an alarm will occur. The alarm is reported in the M-III Restrictions Error Bit (SB00041D) in the CPU Error Status System Register. Refer to the following section for details.

◆ CPU System Status on page 4-18

■ Restrictions Imposed by Σ-V SERVOPACKs

The specifications of MECHATROLINK-III Σ-V-series SERVOPACKs impose the following restrictions on the set value of the high-speed scan time.

Σ-V SERVOPACK Version	Restrictions
Lower than version 21	High-speed scan time set value ≤ (32 × Communications cycle) Example: If the MECHATROLINK-III communications cycle is 250 μs, the set value of the high-speed scan time can be up to 8.0 ms (250 μs × 32).
Version 21 or higher	High-speed scan time set value ≤ (254 × Communications cycle) Example: If the MECHATROLINK-III communications cycle is 250 μs, the set value of the high-speed scan time can be up to 63.50 ms (250 μs × 254).

If these restrictions are not observed, an A.94B Data Setting Warning 2 (Data Out of Range) warning will occur in the SERVOPACK.

◆ I/O Processing

If the high-speed scan time is set to at least 0.5 ms, the I/O service (I/O processing) of the MP2000 Optional Module will be performed every scan.

If the high-speed scan time is set to less than 0.5 ms (0.125 ms or 0.250 ms), the I/O service (I/O processing) of the MP2000 Optional Module will be performed at the filtered basic cycle of 0.5 ms.

The following figures show the timing results for these settings.

■ Example: High-speed Scan Time Set to 0.125 ms

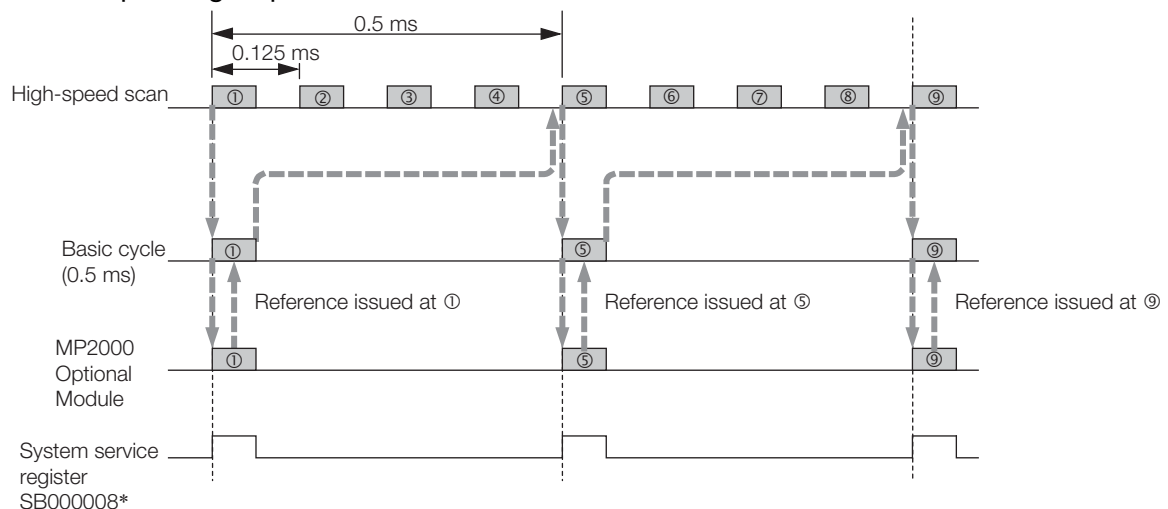

* The purpose of this system service register is to determine from a ladder program whether the I/O scan service is being executed for MP2000 Optional Modules.

■ Example: High-speed Scan Time Set to 0.250 ms

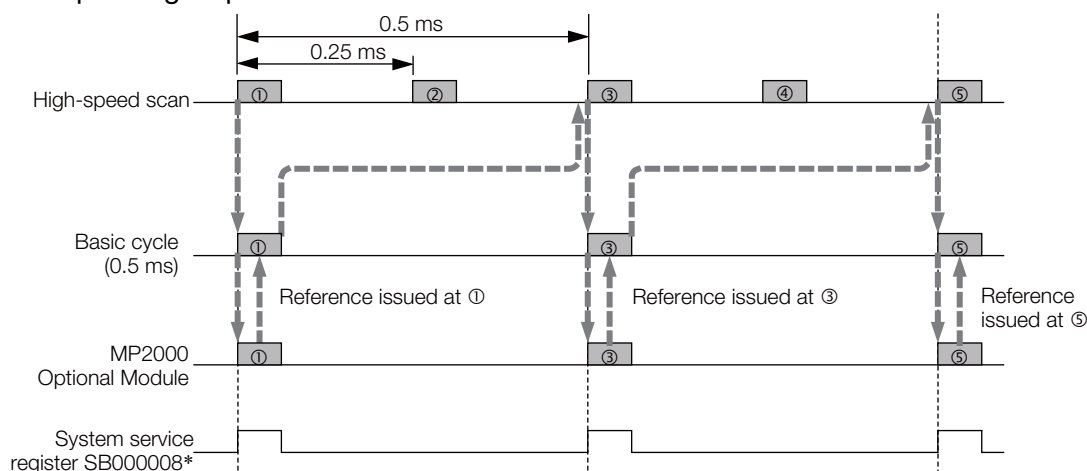

* The purpose of this system service register is to determine from a ladder program whether the I/O scan service is being executed for MP2000 Optional Modules.

■ Example: High-speed Scan Time Set to 0.5 ms

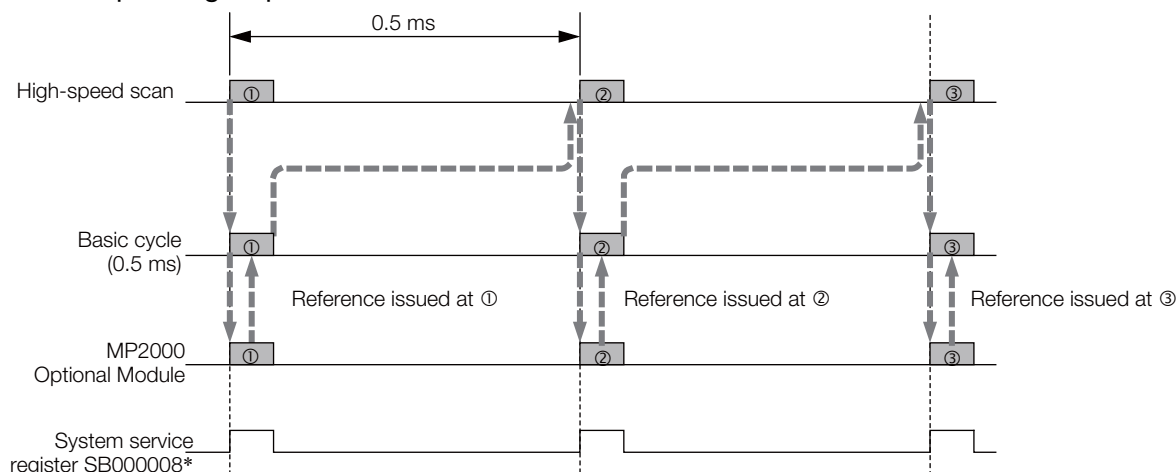

* The purpose of this system service register is to determine from a ladder program whether the I/O scan service is being executed for MP2000 Optional Modules.

Low-speed (L) Scan

The setting range for the low-speed scan time is 2.0 to 300.0 ms (in increments of 0.5 ms).

Information The default low-speed scan time is 200.0 ms.

◆ I/O Processing

During the low-speed scan, the I/O service (I/O processing) is performed every scan, regardless of the set value.

Setting the High-speed and Low-speed Scan Times

Use MPE720 version 7 and perform the procedure given below to set the high-speed and low-speed scan times.

1. Stop the program in the CPU Module.
2. Select **File – Environment Setting** from the menu bar. Alternatively, click the **System Setting Icon** on the Start Tab Page.
The Environment Setting Dialog Box will be displayed.
3. Select **Setup – Scan Time Setting**.
The following dialog box will be displayed.

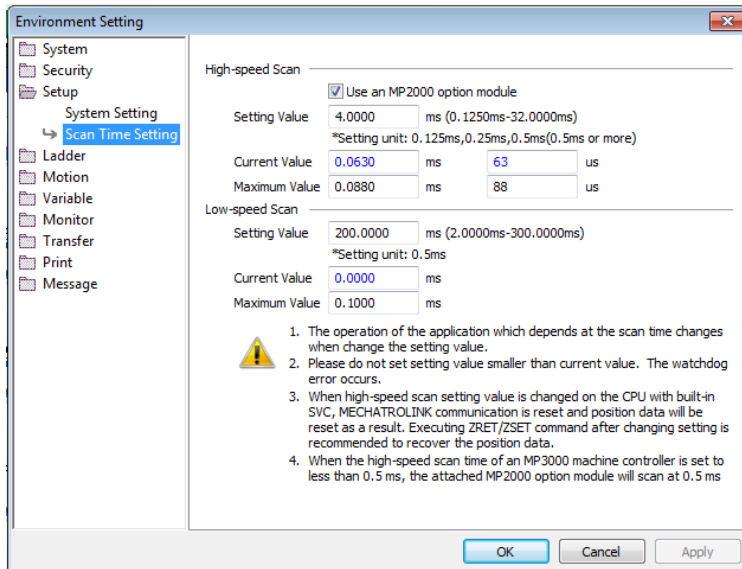

Setting Value: Enter the scan time settings.

Current Value: A value of 0.0 ms is displayed when the MPE720 is offline. Otherwise, the actual processing times for the scans are displayed.

Maximum Value: The maximum processing time for the scan is displayed. You can set the maximum value. The setting is retained until it is exceeded.

4. Enter the high-speed scan time in the **Setting Value** Box under **High-speed Scan**. Enter the low-speed scan time in the **Setting Value** Box under **Low-speed Scan**.

The following table shows the possible set values and default values for each scan time.

Item	Possible Set Values	Default
High-speed Scan Time	0.25 to 32.0 ms (in increments of 0.125 ms)	4.0 ms
Low-speed Scan Time	2.0 to 300.0 ms (in 0.5-ms increments)	200.0 ms

Note: The possible set values and default values depend on the model. Refer to the user's manual for the Module you are using for details.

5. Click the **OK** Button.
The settings will be saved and the Environment Setting Dialog Box will close.



Observe the following precautions when setting the high-speed scan time and low-speed scan time.

1. Set the scan set value so that it is 1.25 times greater than the maximum value.
If the scan set value is too close to the maximum value, the refresh rate of the MPE720 window will noticeably drop and can cause communications timeout errors to occur. If the maximum value exceeds the scan set value, a watchdog error may occur and cause the Machine Controller system to shut down.
2. If you are using MECHATROLINK-II or MECHATROLINK-III, set values that are an integral multiple of the communications cycle. If you change the communications cycle, check the scan time set values.
3. Do not change the scan set value while the Servo is ON. Never change the scan set value while an axis is in motion (i.e., while the motor is rotating). Doing so may cause the motor to rotate out of control.
4. After changing or setting a scan time, always save the data to flash memory.

Keep Latest Value Setting in High-speed/Low-speed Scans

You can use the Keep Latest Value setting to specify the number of scans to hold previous data when an input error occurs. If the input error still exists after the number of scans specified for the Keep Latest Value setting, the input values will be treated as 0. When the input error is removed, reading the input values is resumed automatically. There are separate Keep Latest Value settings for the high-speed scan and the low-speed scan.

◆ Operation

The following figure illustrates the operation for the Keep Latest Value setting.

Keep Latest Value setting: 3 scans for high-speed scan

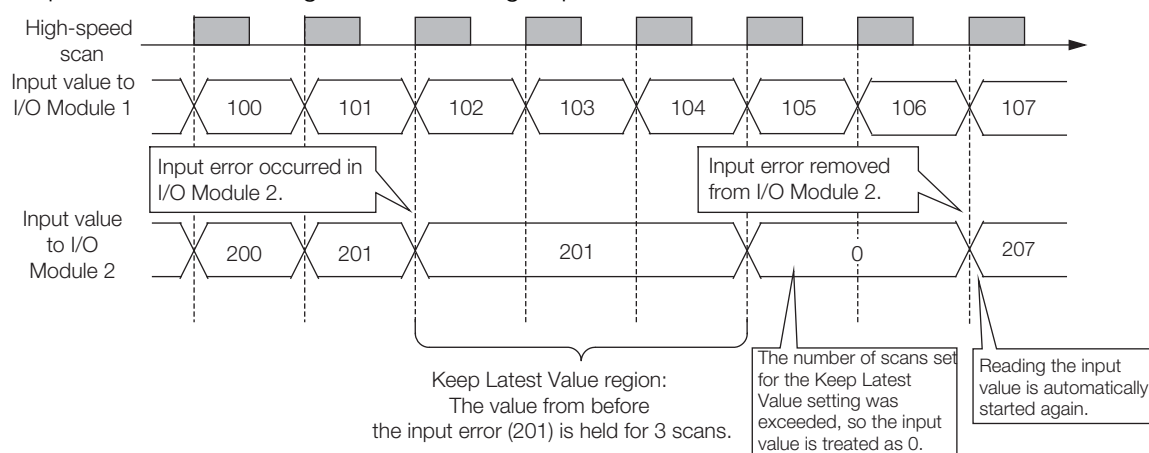

◆ Setting Procedure

Perform the following procedure with MPE720 version 7 to set the Keep Latest Value setting.

1. Select **File – Environment Setting** from the menu bar. Alternatively, click the **System Setting Icon** on the Start Tab Page.
The Environment Setting Dialog Box will be displayed.
2. Select **Setup – System Setting**.
The following dialog box will be displayed.

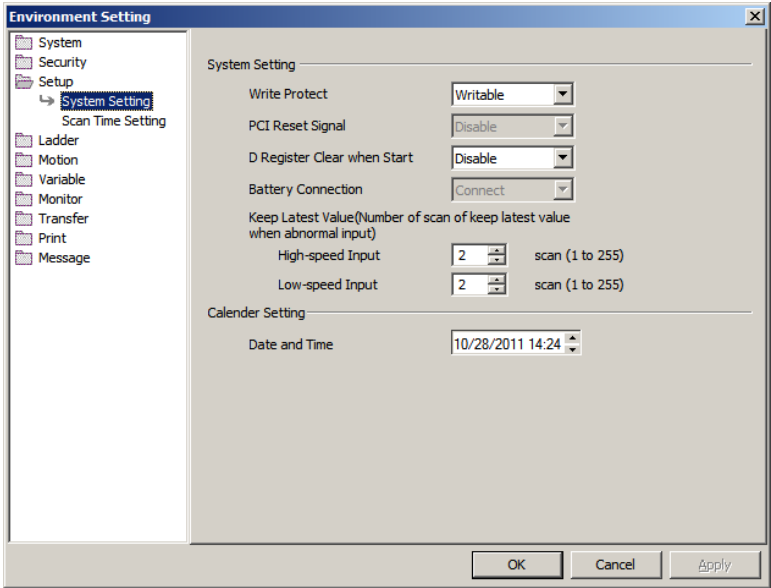

3. Set values in the **High-speed Input** and **Low-speed Input** Boxes in the **Keep Latest Value** Group.

4. Click the **OK** Button.

The settings will be saved and the Environment Setting Dialog Box will close.

Information

The Keep Latest Value setting specifies the number of scans to process before the I/O service clears the input registers.

If the high-speed scan time setting is set to 0.250, the scan at which the input registers are cleared will differ for the MP2000-series Optional Module and the 218IFD, SVC, or SVC32 Function Module that is built into the CPU Unit.

In the following example, an input error occurs simultaneously on the MP2000-series Optional Module and the 218IFD, SVC, SVC32 Function Modules in the CPU Unit when the high-speed scan setting is set to 0.250 ms and the Keep Latest Value setting is set to 5 scans.

The input registers in the 218IFD, SVC, or SVC32 Function Module built into the CPU Unit are cleared on the sixth scan that immediately follows the specified number of scans, whereas on the MP2000-series Optional Module, the input registers are cleared on the seventh service scan that immediately follows the specified number of scans.

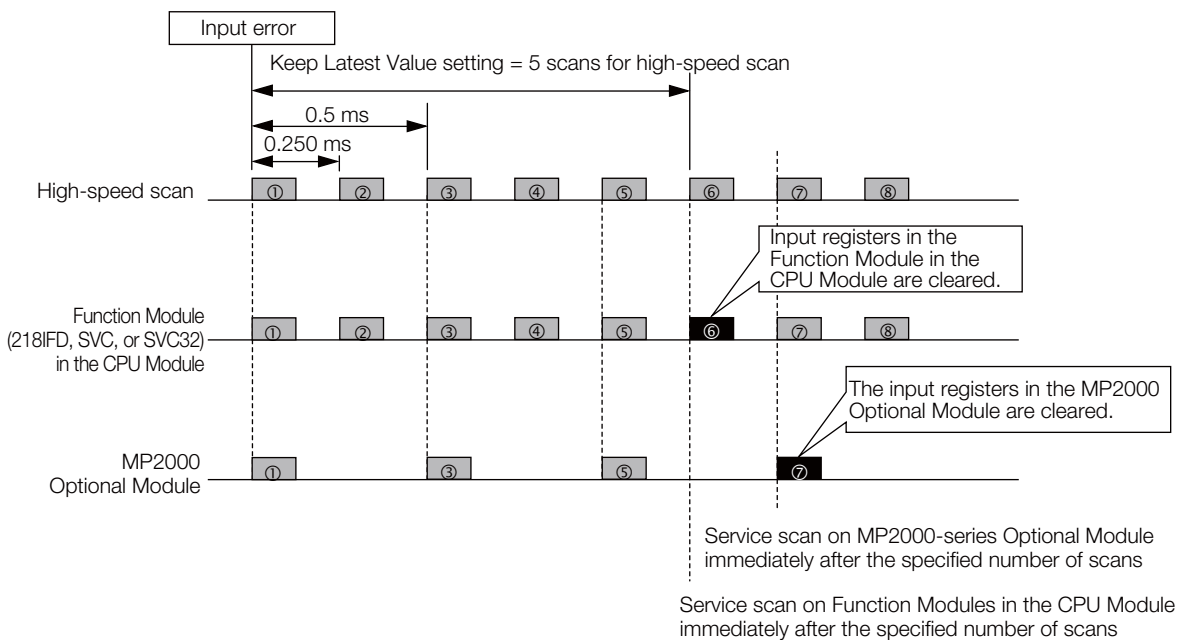

3.2 Function Modules

This section describes the built-in functionality of the CPU Module.

3.2.1 Self Configuration

Self configuration is a feature that automatically recognizes all the built-in functions of the Machine Controller, all of the Optional Modules mounted on Expansion Racks, and all the slave devices that are connected via the MECHATROLINK connector (such as Servo Drives), and creates the module configuration definition files based on that information. Self configuration greatly reduces the steps that are required to set up the system. Use the DIP switch on the CPU Module or use the MPE720 to execute self configuration.

The following figure illustrates self configuration.

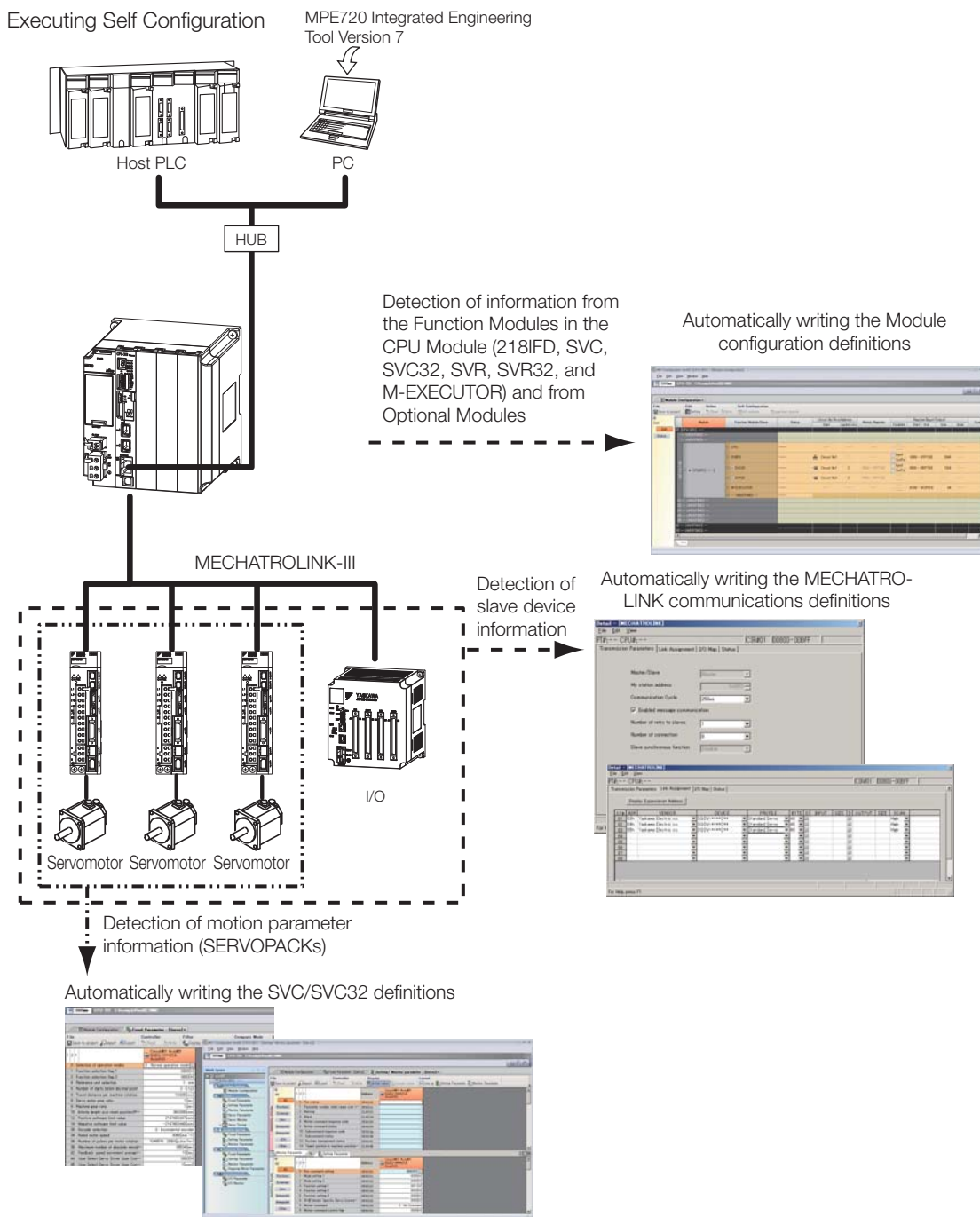

Operating Procedures

This section describes the procedures for executing self configuration.

- Refer to the following section when you perform self configuration for the first time after connecting the devices.

 ◆ *Self Configuration Using the DIP Switch* on page 3-36

- If the Machine Controller and the MPE720 are already connected, the self configuration can be performed by using the MPE720.

 ◆ *Self Configuration Using the MPE720* on page 3-39

◆ Self Configuration Using the DIP Switch

The procedure for executing self configuration using the DIP switch depends on whether self configuration is being done for the first time since the devices were connected, or if SERVOPACKs or other devices have been added.

Both procedures are described below.

■ First Self Configuration after Connecting the Devices

The following procedure performs a new self configuration of the CPU Module, and creates new definition files.



Important

1. Before performing this procedure, turn ON the power supply to the SERVOPACKs and other devices.
2. This procedure will clear the following data:
 - All definition files
 - All user programs
 - All registers

1. Turn OFF the power supply to the Base Unit.

2. Turn ON only the INIT and CNFG pins on the DIP switches (mode switches) on the CPU Module.

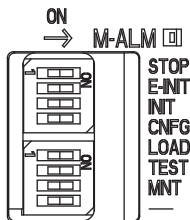

3. Turn ON the power supply to the Base Unit.

Self configuration will be executed.

4. Confirm that the status indicators on the CPU Module change in the following way:

- RDY: Goes out, and then lights.
- RUN: Goes out, flashes, and then lights.

- Turn OFF the INIT and CNFG pins on the DIP switches (mode switches) on the CPU Module.

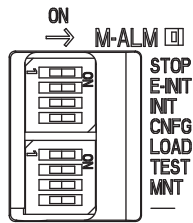

Important

- INIT Pin on the DIP Switch and RAM Data

If the power supply is turned OFF and ON again when the INIT pin on the Machine Controller SW1 DIP switch is turned ON, the data in RAM will be cleared.

If the power supply is turned OFF and ON again when the INIT pin is turned OFF, the data from the flash memory will be loaded and will overwrite the RAM data. Therefore, if the power supply must be turned OFF while writing or editing a program, make sure you save the data to the Machine Controller's flash memory to protect the RAM data.

- Power Interruptions after Self Configuration

After performing self configuration, turn OFF the power supply to the Machine Controller only after the definition data is saved to the flash memory of the Machine Controller.

If by chance, the power supply is turned OFF before the data is saved, perform self configuration again.

Refer to the following manual for details on saving data to the flash memory.

MP3000 Series Machine Controller System Setup Manual (Manual No.: SIEP C880725 00)

■ After Adding SERVOPACKs, Optional Modules, and Other Devices

The following procedure will create the definitions for devices and Function Modules that are newly detected by MECHATROLINK communications. This procedure will not update any of the definitions that were made for existing devices and Function Modules. The definitions before self configuration will be retained.



Important

Before performing this procedure, turn ON the power supply to the SERVOPACKs and other devices.

- Turn OFF the power supply to the Base Unit.
- Turn ON only the CNFG pin on the DIP switches (mode switches) on the CPU Module.

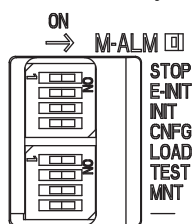

- Turn ON the power supply to the Base Unit.
Self configuration will be executed.
- Confirm that the status indicators on the CPU Module change in the following way:
 - RDY: Goes out, and then lights.
 - RUN: Goes out, flashes, and then lights.

5. Turn OFF the CNFG pin on the DIP switches (mode switches) on the CPU Module.

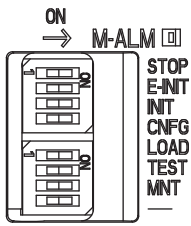

Important

Power Interruptions after Self Configuration

After performing self configuration, turn OFF the power supply to the Machine Controller only after the definition data is saved to the flash memory of the Machine Controller.

If by chance, the power supply is turned OFF before the data is saved, perform self configuration again.

Refer to the following manual for details on saving data to the flash memory.

MP3000 Series Machine Controller System Setup Manual (Manual No.: SIEP C880725 00)

◆ Self Configuration Using the MPE720

There are two types of self configuration that can be performed with the MPE720.

- Self configuration of all Modules: Use this mode when the system is being set up for the first time, or after the entire system has been changed.
- Self configuration of specified Modules: Use this mode when a part of the system has been changed. This process will automatically recognize all devices that have been added or removed, and automatically generate definition files for them.

■ Self Configuration of All Modules



Important

Before performing this procedure, turn ON the power supply to the SERVOPACKs and other devices.

1. Click the **Module Configuration** Icon on the Start Tab Page.

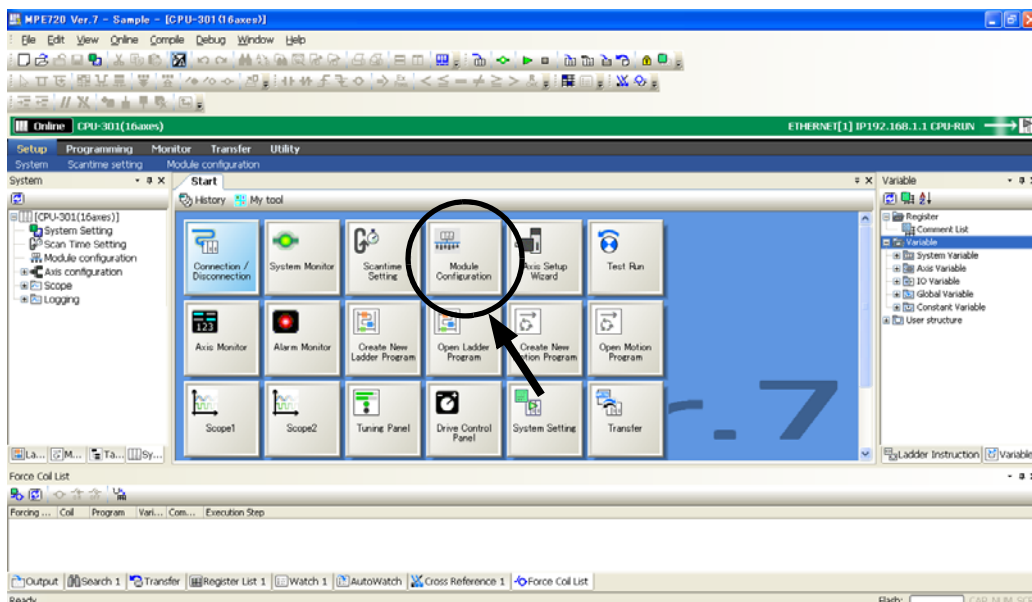

The following Module Configuration Tab Page will be displayed.

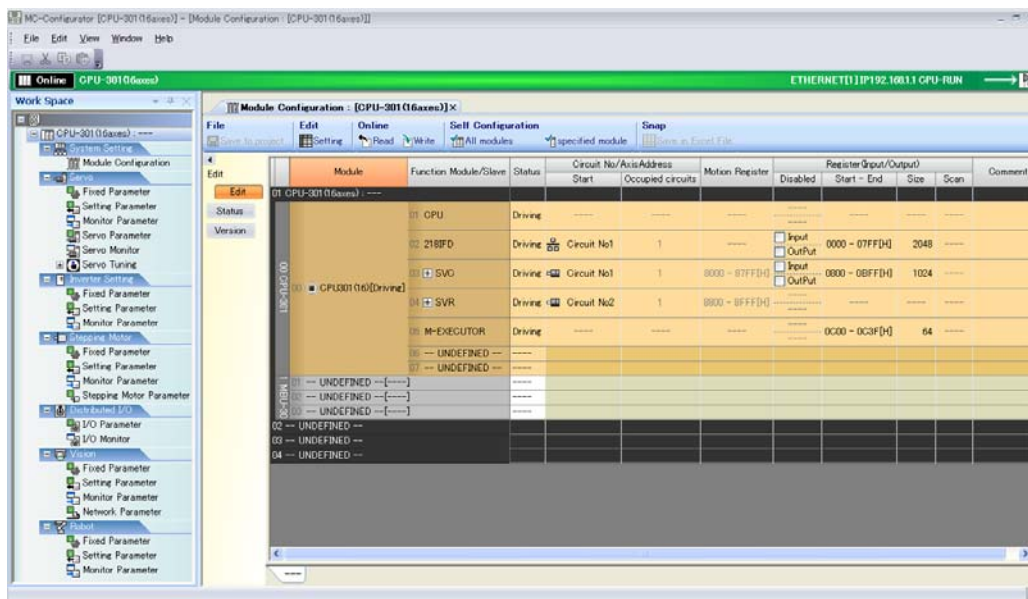

3.2 Function Modules

3.2.1 Self Configuration

2. Click the **Module** Button.

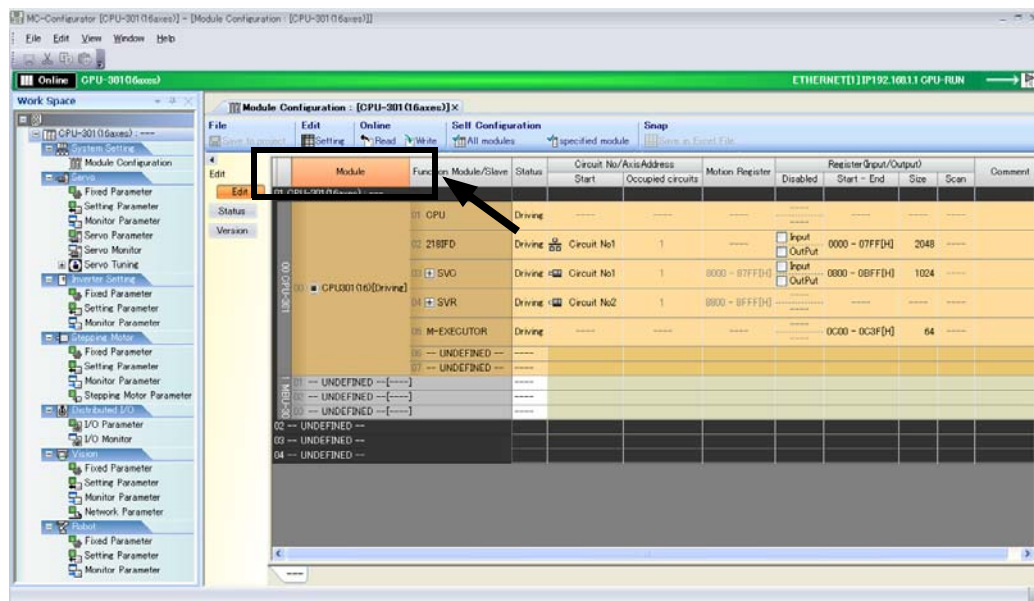

3. Click the **All modules** Button on the Launcher.

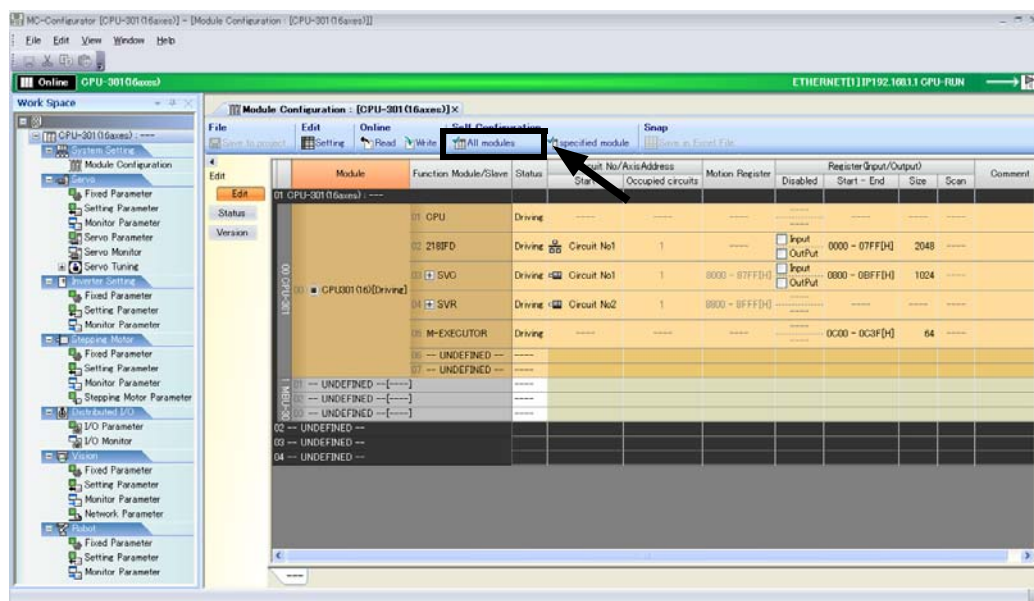

The MC-Configurator Dialog Box will be displayed.

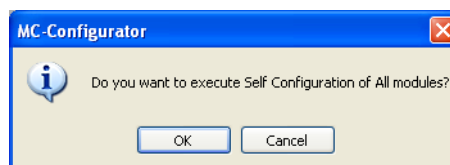

4. Click the **OK** Button. Self configuration will be executed.

■ Self Configuration of Specified Modules



Before performing this procedure, turn ON the power supply to the SERVOPACKs and other devices.

1. Click the **Module Configuration** Icon on the Start Tab Page.

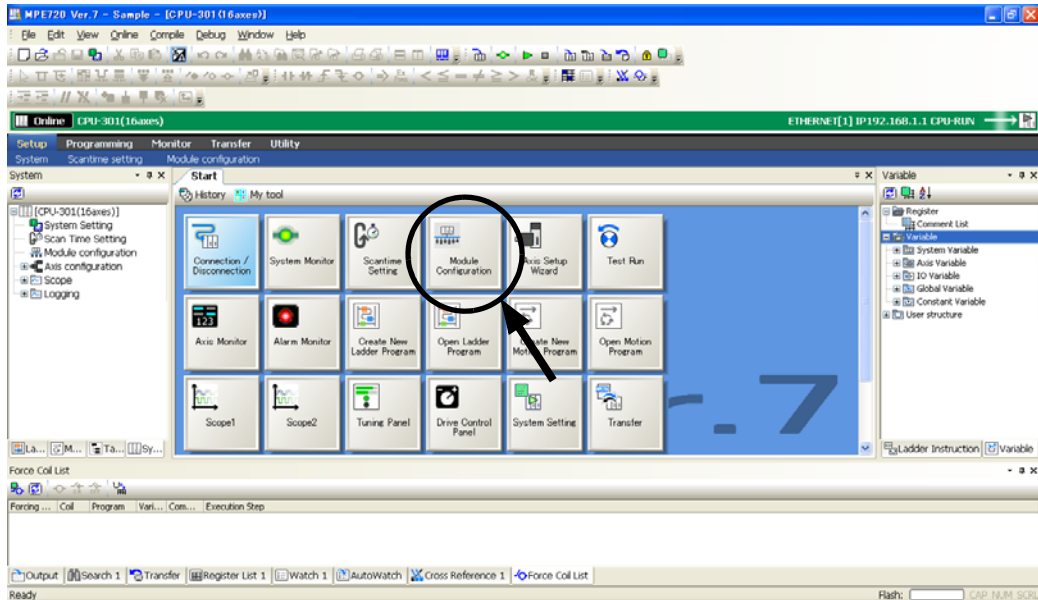

The following Module Configuration Tab Page will be displayed.

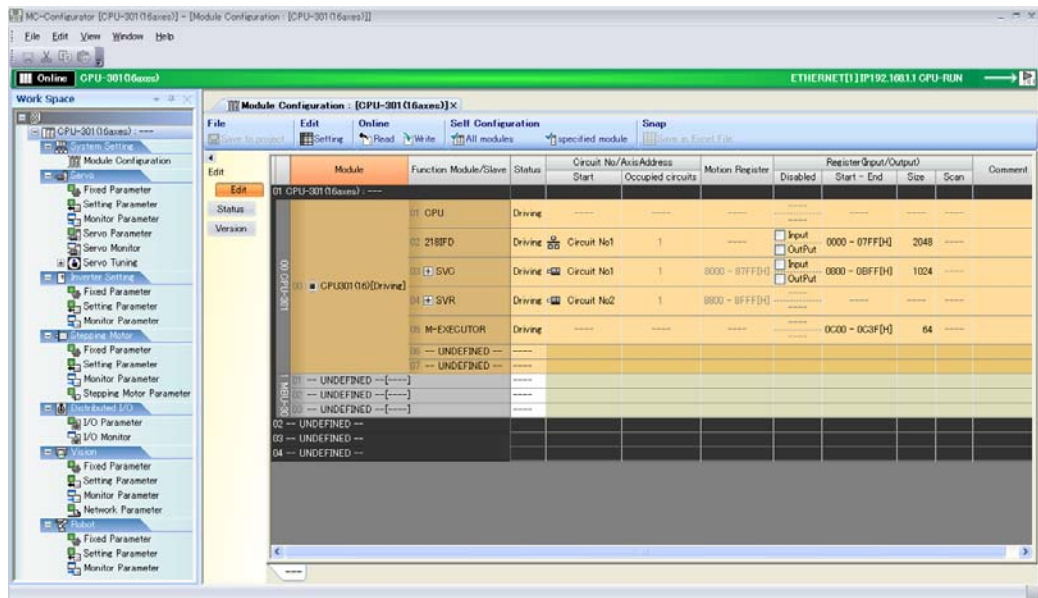

2. In the **Function Module/Slave** Column, select the Modules to configure using self configuration.

3.2 Function Modules

3.2.1 Self Configuration

3. Click the **specified module** Button on the Launcher.

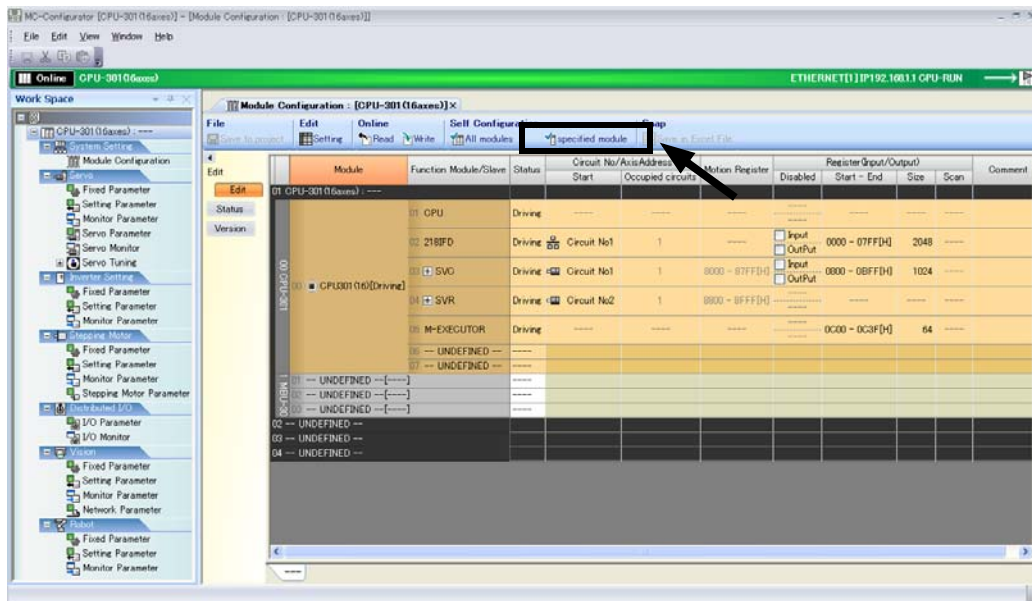

The MC-Configurator Dialog Box will be displayed.

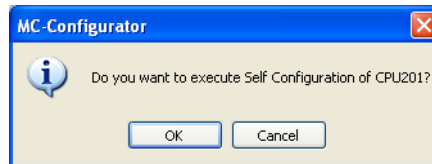

4. Click the **OK** Button.

Self configuration will be executed only for the new devices that are detected by MECHATROLINK communications.

Definition Information Updated by Self Configuration

The definition information that is updated by self configuration is described below.

Information This procedure will not update any of the definitions that were made for existing devices and Function Modules. The definitions before self configuration will be retained.

◆ I/O Registers

I/O registers are assigned to the Function Modules (218IFD, SVC, SVC32, SVR, SVR32, M-EXECUTOR, and CPUIF) in the CPU Module as shown below.

I/O registers will also be automatically assigned to any Optional Modules mounted on the Base Unit.

Item		Settings after Self Configuration						
218IFD		<ul style="list-style-type: none"> • First I/O registers: IW00000 and OW00000 • Last I/O registers: IW007FF and OW007FF (input registers: IW00000 to IW007FF, output registers: OW00000 to OW007FF) 						
SVC/ SVC32	MECHATROLINK	<ul style="list-style-type: none"> • First I/O registers: IW00800 and OW00800 • Last I/O registers: IW00BFF and OW00BFF (input registers: IW00800 to IW00BFF, output registers: OW00800 to OW00BFF) 						
	Motion parameters	<table border="1"> <thead> <tr> <th>SVC</th> <th>Settings after Self Configuration</th> </tr> </thead> <tbody> <tr> <td>• First motion registers: IW08000 and OW08000</td> <td>• Last motion registers: IW087FF and OW087FF (input registers: IW08000 to IW087FF, output registers: OW08000 to OW087FF)</td> </tr> <tr> <td>• First motion registers: IW08000 and OW08000</td> <td>• Last motion registers: IW08FFF and OW08FFF (input registers: IW08000 to IW08FFF, output registers: OW08000 to OW08FFF)</td> </tr> </tbody> </table>	SVC	Settings after Self Configuration	• First motion registers: IW08000 and OW08000	• Last motion registers: IW087FF and OW087FF (input registers: IW08000 to IW087FF, output registers: OW08000 to OW087FF)	• First motion registers: IW08000 and OW08000	• Last motion registers: IW08FFF and OW08FFF (input registers: IW08000 to IW08FFF, output registers: OW08000 to OW08FFF)
SVC	Settings after Self Configuration							
• First motion registers: IW08000 and OW08000	• Last motion registers: IW087FF and OW087FF (input registers: IW08000 to IW087FF, output registers: OW08000 to OW087FF)							
• First motion registers: IW08000 and OW08000	• Last motion registers: IW08FFF and OW08FFF (input registers: IW08000 to IW08FFF, output registers: OW08000 to OW08FFF)							
SVR/ SVR32	Motion parameters	<table border="1"> <thead> <tr> <th>SVR</th> <th>Settings after Self Configuration</th> </tr> </thead> <tbody> <tr> <td>• First motion registers: IW08800 and OW08800</td> <td>• Last motion registers: IW08FFF and OW08FFF (input registers: IW08800 to IW08FFF, output registers: OW08800 to OW08FFF)</td> </tr> <tr> <td>• First motion registers: IW09000 and OW09000</td> <td>• Last motion registers: IW09FFF and OW09FFF (input registers: IW09000 to IW09FFF, output registers: OW09000 to OW09FFF)</td> </tr> </tbody> </table>	SVR	Settings after Self Configuration	• First motion registers: IW08800 and OW08800	• Last motion registers: IW08FFF and OW08FFF (input registers: IW08800 to IW08FFF, output registers: OW08800 to OW08FFF)	• First motion registers: IW09000 and OW09000	• Last motion registers: IW09FFF and OW09FFF (input registers: IW09000 to IW09FFF, output registers: OW09000 to OW09FFF)
	SVR	Settings after Self Configuration						
• First motion registers: IW08800 and OW08800	• Last motion registers: IW08FFF and OW08FFF (input registers: IW08800 to IW08FFF, output registers: OW08800 to OW08FFF)							
• First motion registers: IW09000 and OW09000	• Last motion registers: IW09FFF and OW09FFF (input registers: IW09000 to IW09FFF, output registers: OW09000 to OW09FFF)							
M-EXECUTOR		<ul style="list-style-type: none"> • First I/O registers: IW00C00 and OW00C00 • Last I/O registers: IW00C3F and OW00C3F (input registers: IW00C00 to IW00C3F, output registers: OW00C00 to OW00C3F) 						

◆ 218IFD Definition

Item	Settings after Self Configuration
Local IP Address	192.168.1.1
Subnet Mask	255.255.255.0
Gateway IP Address	0.0.0.0
Module Name Definition	CONTROLLER NAME
Engineering Port	9999 (UDP)
MEMOBUS Response Time	0 s
Count of Retry	0

Note: Self configuration sets up the 218IFD for an engineering communications connection with the MPE720. If you want to use MEMOBUS message communications, manually set up automatic reception or I/O message communications, or use MSG-SNDE and MSG-RCVE functions.

◆ MECHATROLINK Communications Definition

■ When Set as the Master

Item	Settings after Self Configuration
Master/Slave	Master
My station address	0x0001
Communication Cycle	250 μ s
Message Communications	Enabled
Number of Retry to Slaves	1
Number of connection	8
Slave synchronous function	Disabled

■ When Set as a Slave

Item	Settings after Self Configuration
Master/Slave	Slave
My station address	0x0003
Communication Cycle	–
Message Communications	Disabled
Number of Retry to Slaves	–
Number of connection	1
Slave synchronous function	Disabled

Information

To use the Module as a slave, set the parameter settings in the MECHATROLINK communications definition to **Slave** before performing self configuration in the MPE720.

◆ SVC/SVC32 Definitions

Refer to the following manual for details.

📖 MP3000 Series Motion Control User's Manual (Manual No.: SIEP C880725 11)

◆ SVR/SVR32 Definitions

Item	Settings after Self Configuration
SVR Defined Axes	16 axes (unused axes)
SVR32 Defined Axes	32 axes (unused axes)

◆ M-EXECUTOR Definition

Item	Settings after Self Configuration
Program Definition Number	8
Program Assignments	Not supported.
Control Register Assignments	Not supported.

3.2.2 Communications Function Module (218IFD)

This Function Module is used for communications with a host device.

The following table describes the communication features.

Function Module	Features	Remarks
Ethernet	The MP3000 Controller supports multiple protocols to enable general-purpose Ethernet communications with PLCs and touch panels from various manufacturers without writing special applications.	<ul style="list-style-type: none"> Supported Protocols MODBUS/TCP, OMRON, MELSEC A-compatible 1E/QnA-compatible 3E, Extended MEMOBUS, MEMOBUS, and TOYOPUC

Setting Method

Settings are made on the 218IFD Dialog Box after connecting the MP3000-series Controller to the host device. Use the following procedure to display the 218IFD Dialog Box. Refer to the following manual for details on settings.

📖 MP3000 Series Communications User's Manual (Manual No.: SIEP C880725 12)

1. Connect the Machine Controller to the PC, and start the MPE720.
Refer to the following manual for details.
📖 MP3000 Series Machine Controller System Setup Manual (Manual No.: SIEP C880725 00)
2. Execute self configuration as required.
📖 *Operating Procedures* on page 3-36
3. Click the **Module Configuration** Icon on the Start Tab Page.

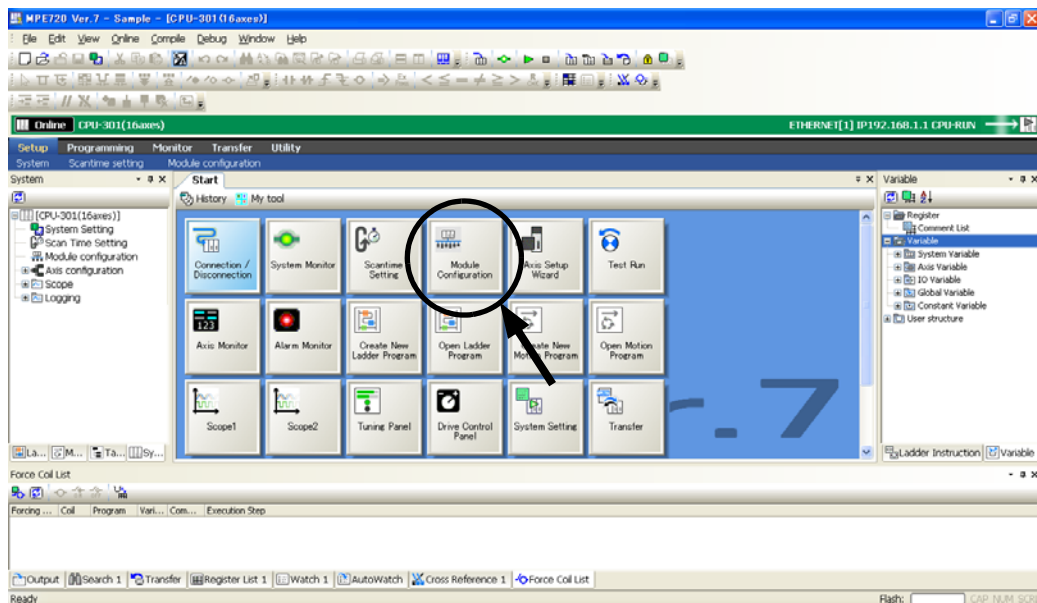

3.2 Function Modules

3.2.2 Communications Function Module (218IFD)

The following Module Configuration Tab Page will be displayed.

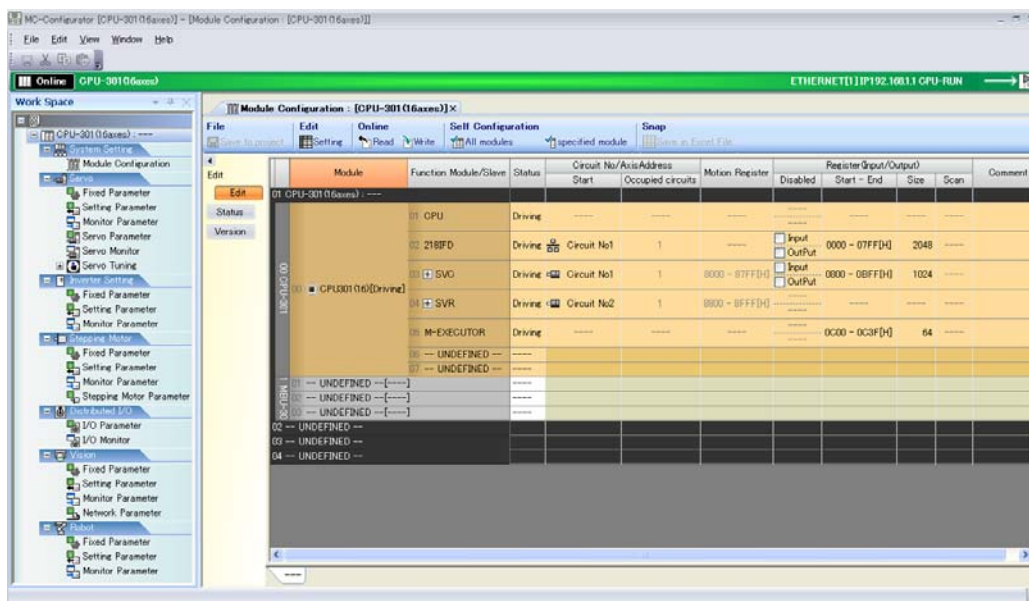

4. Double-click the 218IFD cell.

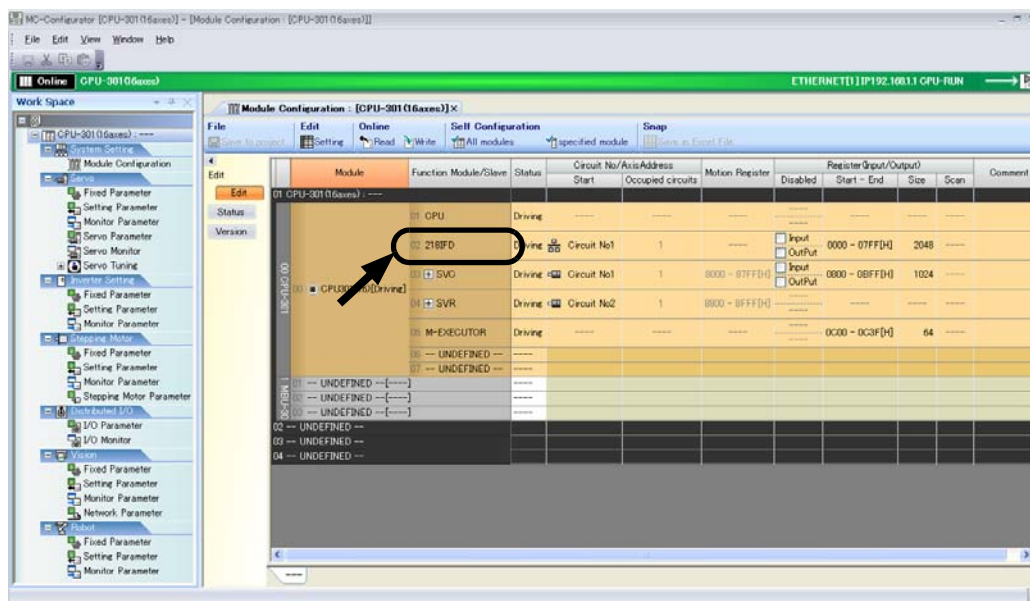

The 218IFD Detail Definition Dialog Box will be displayed.

Refer to the following manual for details on settings.

MP3000 Series Communications User's Manual (Manual No.: SIEP C880725 12)

3.2.3 Motion Control Function Modules (SVC, SVC32, SVR, and SVR32)

The Motion Control Function Module is used for communications with a MECHATROLINK communications device.

There are two types of Motion Control Function Modules, the SVC and SVC32 and the SVR and SVR32. Both types can provide the following forms of motion control.

- Position control
- Synchronized phase control
- Torque control*
- Speed control*

* The SVR and SVR32 contain some parameters that you cannot set or monitor.

Information Motion fixed and setting parameters must be set to use these controls.

The features of the SVC and SVR are described below.

Function Module	Features
SVC/SVC32	Controls MECHATROLINK-III-compatible interface devices, such as Servo Drives and I/O Modules.
SVR/SVR32	Provides an interface for virtual axes. This allows you to test programs and create references without connecting to physical motors.

Refer to the following manual for details.

 MP3000 Series Motion Control User's Manual (Manual No.: SIEP C880725 11)

Setting Method

Settings are made in the locations given below after the MP3000-series Controller is connected to the MECHATROLINK device.

- MECHATROLINK Dialog Box
- SVC/SVC32 Definition Tab Page

Use the following procedure to display the tab pages and dialog boxes. Refer to the following manual for details on settings.

 MP3000 Series Motion Control User's Manual (Manual No.: SIEP C880725 11)

1. Connect the Machine Controller to the PC, and start the MPE720.

Refer to the following manual for details.

 MP3000 Series Machine Controller System Setup Manual (Manual No.: SIEP C880725 00)

2. Execute self configuration as required.

 *Operating Procedures* on page 3-36

3.2 Function Modules

3.2.3 Motion Control Function Modules (SVC, SVC32, SVR, and SVR32)

3. Click the **Module Configuration** Icon on the Start Tab Page.

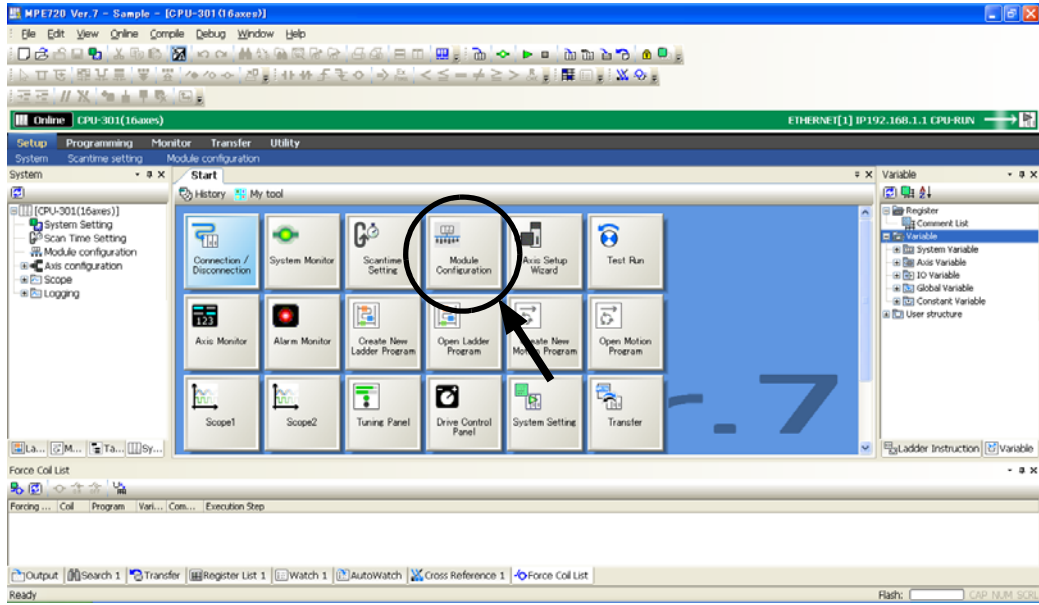

The following Module Configuration Tab Page will be displayed.

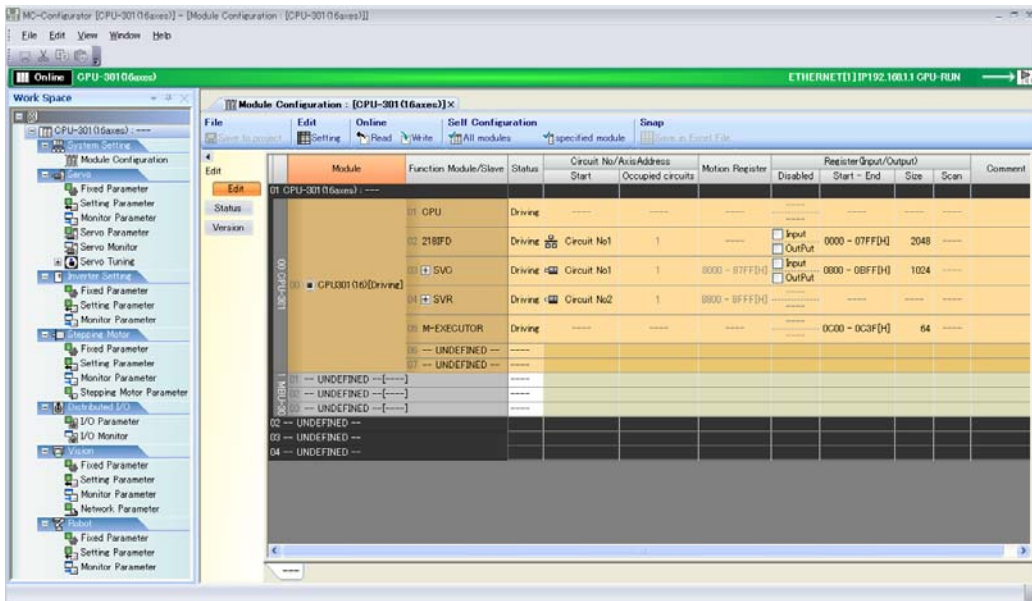

Cells for SVC/SVC32 settings

Cells for SVR/SVR32 settings

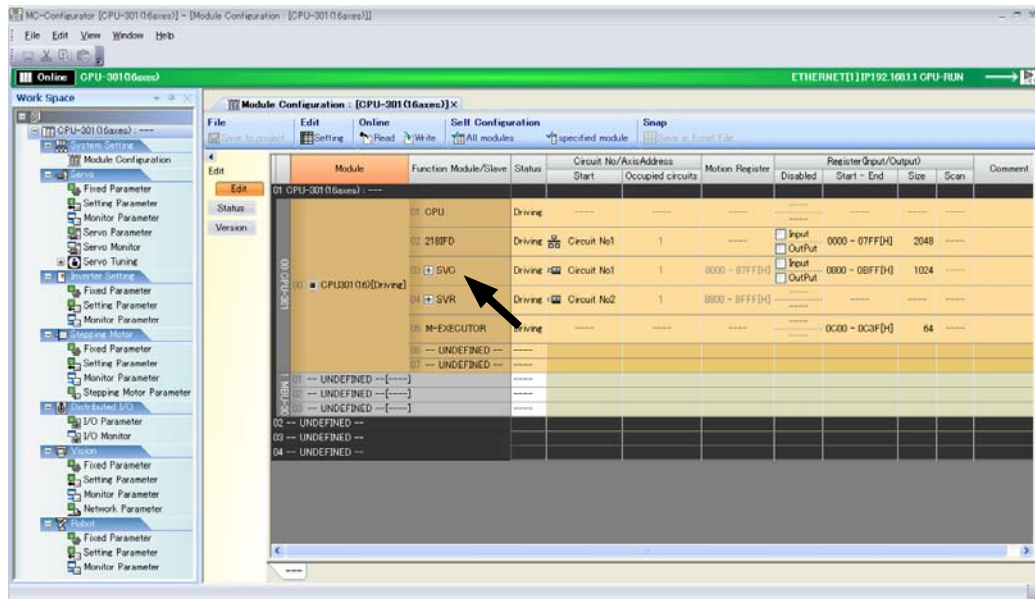
4. Double-click the **SVC/SVC32** cell in the Module Configuration Definition Tab Page.

The MECHATROLINK Communications Definition Dialog Box is displayed.

Information If more than one Module is mounted, select the Module to be checked or set.

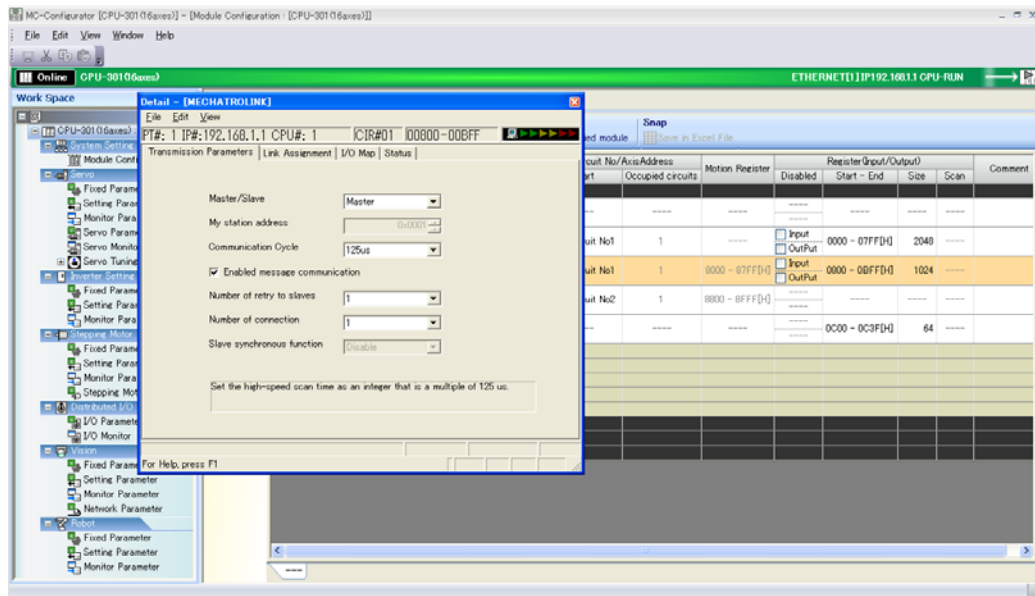

5. Set the MECHATROLINK communications definitions as required.

Refer to the following manual for details on settings.

📖 MP3000 Series Motion Control User's Manual (Manual No.: SIEP C880725 11)

6. Click the **Close** Button on the MECHATROLINK Communications Definition Dialog Box.

3.2 Function Modules

3.2.3 Motion Control Function Modules (SVC, SVC32, SVR, and SVR32)

7. Select **View – Work Space** from the menu bar.

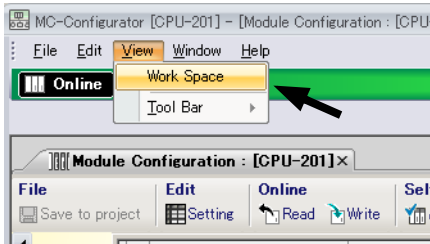

The Work Space Pane is displayed on the left side of the MC-Configurator Window.

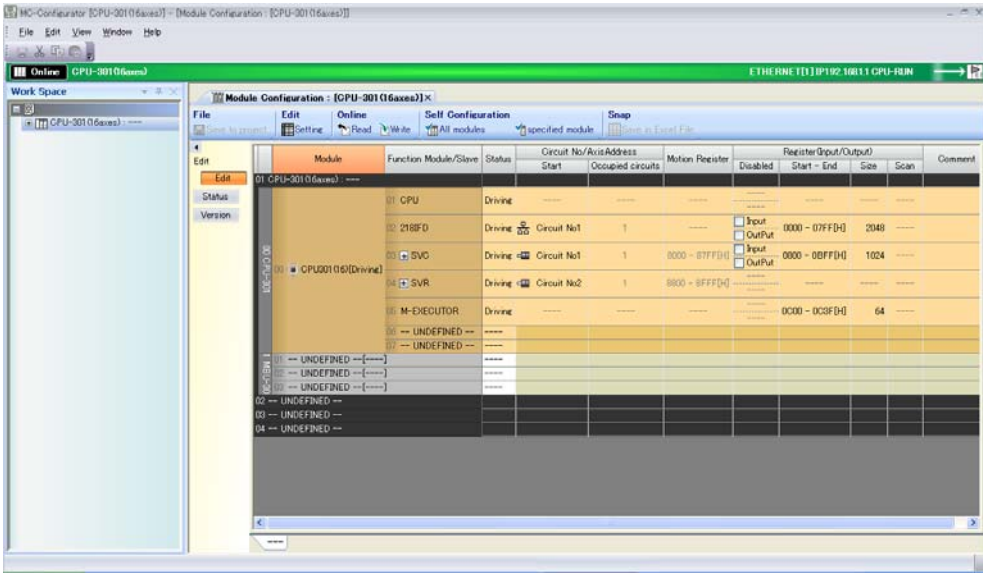

8. Click the **Expand [+]** Button beside each program in the Work Space Pane to display motion parameters as shown below.

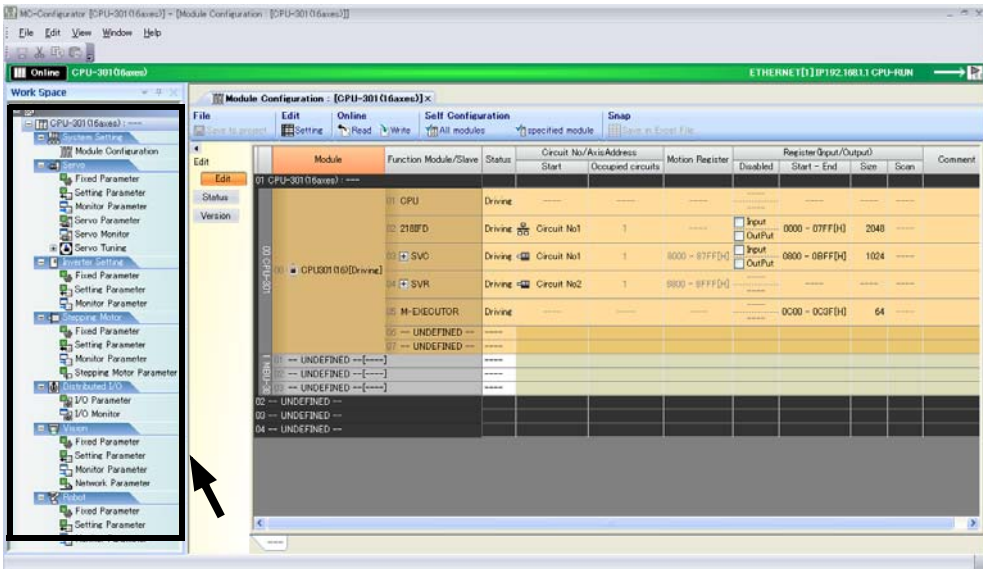

9. Double-click the motion parameter to set or monitor.

The Axis Display Selection Dialog Box (“Display in axis selected”) will be displayed.

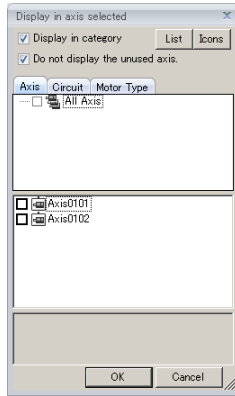

10. Select the axis to set or monitor, and then click the **OK** Button.

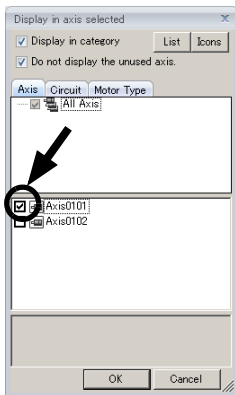

The SVC/SVC32 Definition Tab Page for the selected motion parameters will be displayed.

Information To change which motion parameters are displayed, double-click the required motion parameters in the Work Space Pane.

The following examples show the SVC/SVC32 Definition Tab Page for each group of motion parameters.

- Fixed Parameters Tab Page

Module Configuration : [CPU-201]		Fixed Parameter : [CPU-201] - [Servo]x	
Save to project Import Export Read Write Display in axis selected Comparing axis Save in Excel File			
1	2	*	Circuit#01 Axis#01 SGDV-***21A Axis0101
0	: Selection of operation modes		0 : Normal operation mode
1	: Function selection flag 1		0000[H]
2	: Function selection flag 2		0000[H]
4	: Reference unit selection		0 : pulse
5	: Number of digits below decimal point		3 : 0.123
6	: Travel distance per machine rotation		10000[pulse]
8	: Servo motor gear ratio		1[rev]
9	: Machine gear ratio		1[rev]
10	: Infinite length axis reset position(P...		360000[pulse]
12	: Positive software limit value		2147483647[pulse]
14	: Negative software limit value		-2147483648[pulse]
30	: Encoder selection		0 : Incremental encoder
34	: Rated motor speed		3000[min^{-1}]
36	: Number of pulses per motor rotation		65536 : 16Bit[pulse/rev]
38	: Maximum number of absolute encod...		65534[rev]
42	: Feedback speed movement averagi...		10[ms]
44	: User Select Servo Driver User Con...		0000[H]
45	: User Select Servo Driver User Con...		1[word]

3.2 Function Modules

3.2.3 Motion Control Function Modules (SVC, SVC32, SVR, and SVR32)

- Setting/Monitor Parameters Tab Page

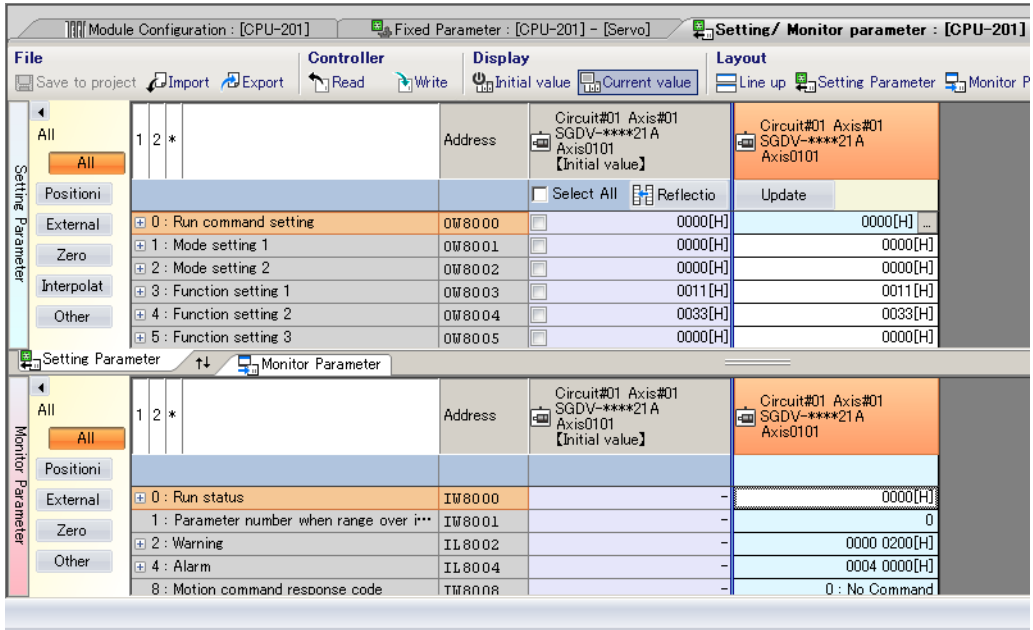

- Servo/Servo Monitor Parameters Tab Page

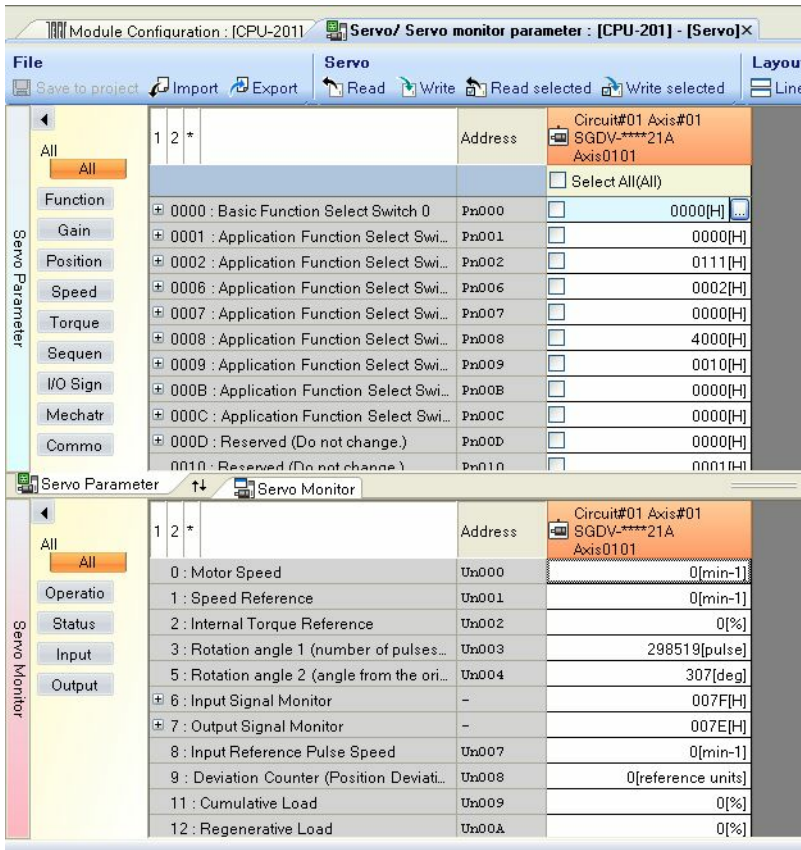

11. Set the SVC/SVC32 definitions as required.

Refer to the following manual for details on settings.

MP3000 Series Motion Control User's Manual (Manual No.: S1EP C880725 11)

3.2.4 The M-EXECUTOR

This section describes the functionality of the M-EXECUTOR Motion Executor and the contents of its various displays.



Term

The M-EXECUTOR is a software module that executes motion and sequence programs.

Introduction

The M-EXECUTOR provides the following merits:

- Motion programs can be executed without using a ladder program.
Motion programs can be executed without placing MSEE instructions in the ladder programs.

Information It is still possible to use MSEE instructions in the ladder programs.

- Motion programs can be controlled without using the ladder programs.
Motion programs can be controlled directly from a host PLC.
- Sequence control can be written in motion language.
A sequence program can be used in place of a ladder program.
Refer to the following manuals for instructions that can be used in sequence programs.
 MP3000 Series Motion Programming Manual (Manual No.: SIEP C880725 14)

Information The execution of a sequence program is completed in one scan.
Sequence programs are written using the same text-based language as motion programs.

Using the M-EXECUTOR

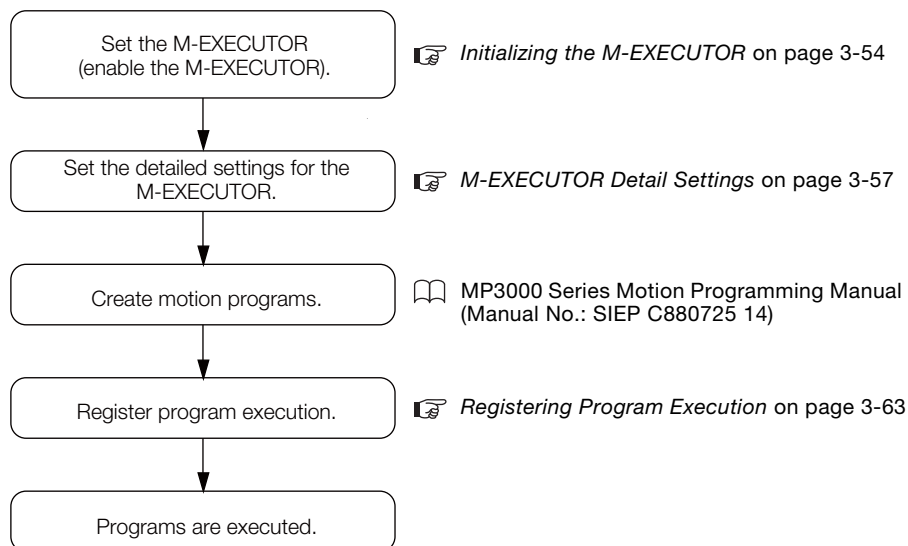

Initializing the M-EXECUTOR

Use the following procedure to initialize the M-EXECUTOR.

1. Click the **Module Configuration** Icon on the Start Tab Page.

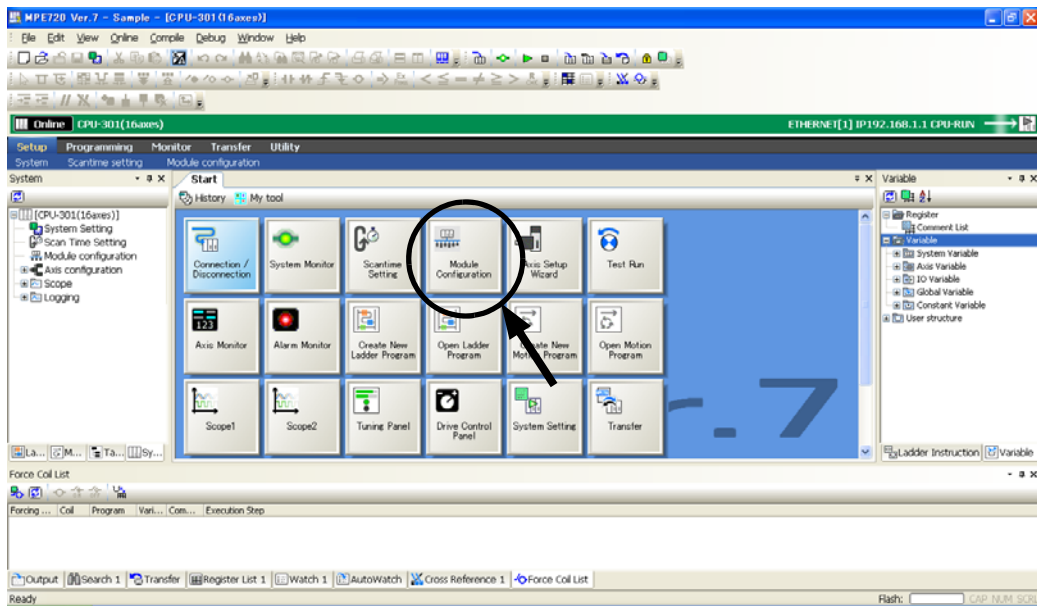

The Module Configuration Tab Page will be displayed.

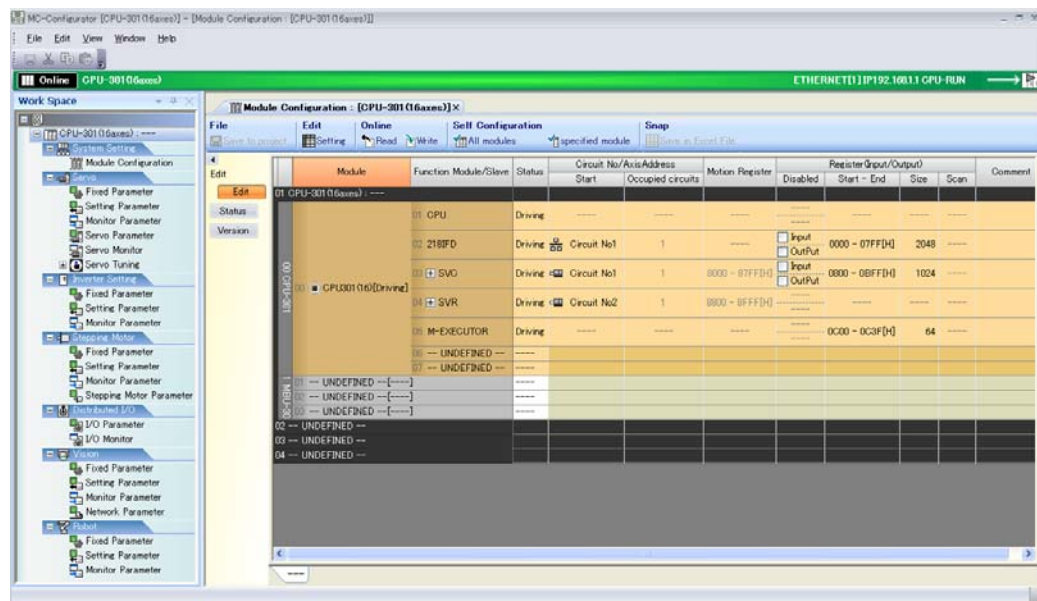

2. Double-click the **M-EXECUTOR** cell.

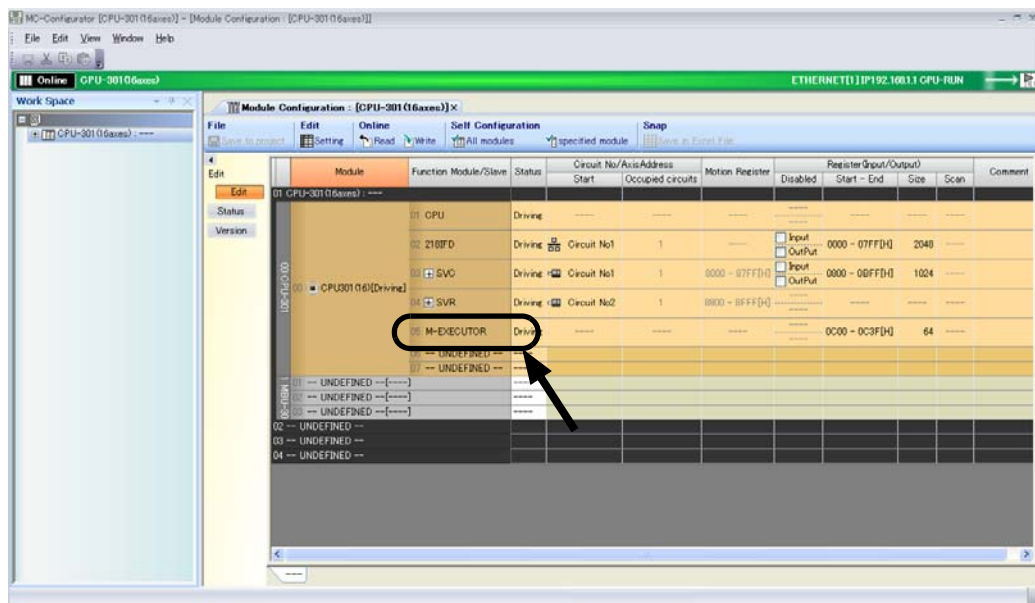

The M-EXECUTOR Definition Dialog Box will be displayed.

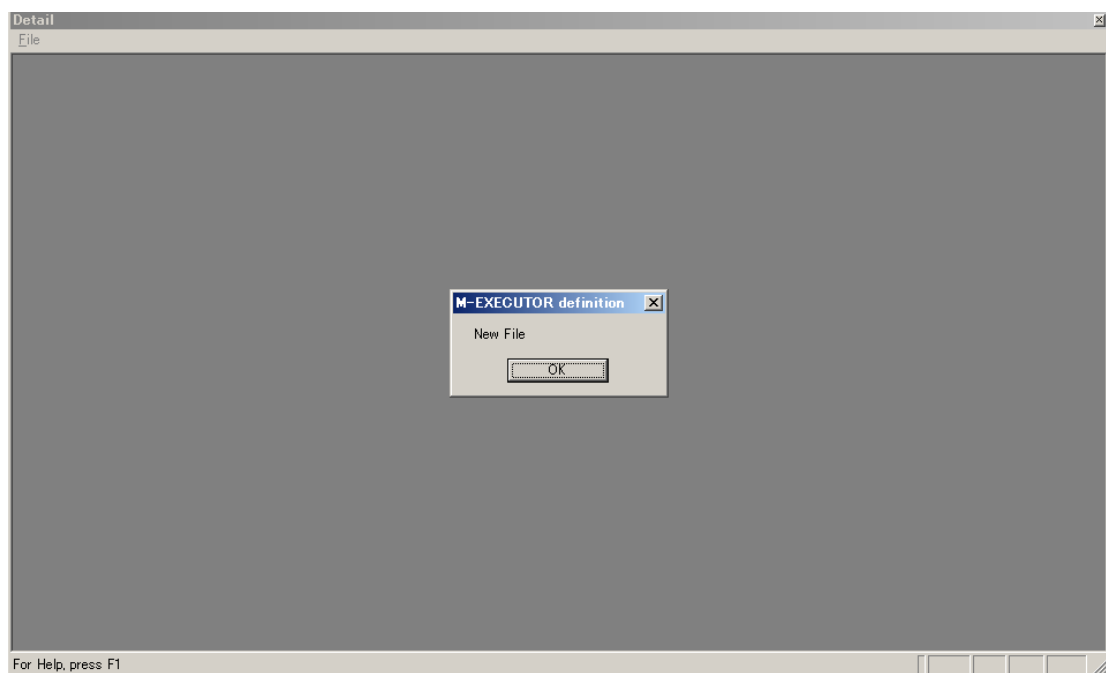

- 3. Click the **OK** Button.
The Detail Definition Dialog Box will be displayed.

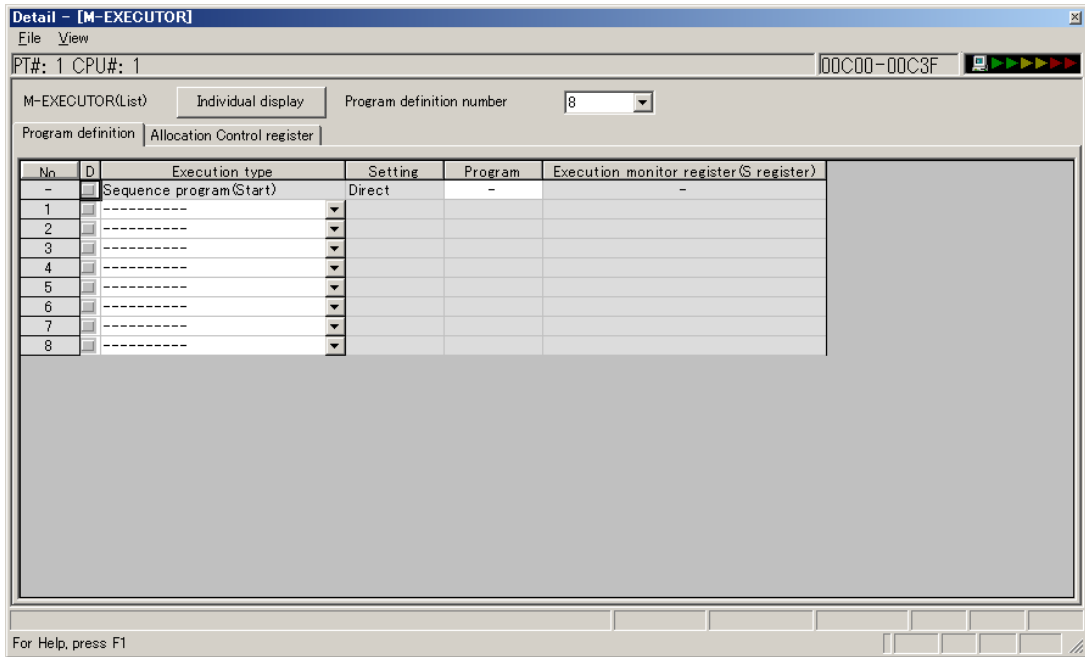

- 4. Select **File – Save** from the toolbar.
The M-EXECUTOR definitions will be saved.

M-EXECUTOR Detail Settings

The detailed settings for the M-EXECUTOR are performed on the Module Configuration Tab Page and the Detail Definition Dialog Box.

This section provides the procedures to display this tab page and dialog box, and describes their contents.

◆ Module Configuration Tab Page

Use the following procedure to display the Module Configuration Tab Page.

- Click the **Module Configuration** Icon on the Start Tab Page.

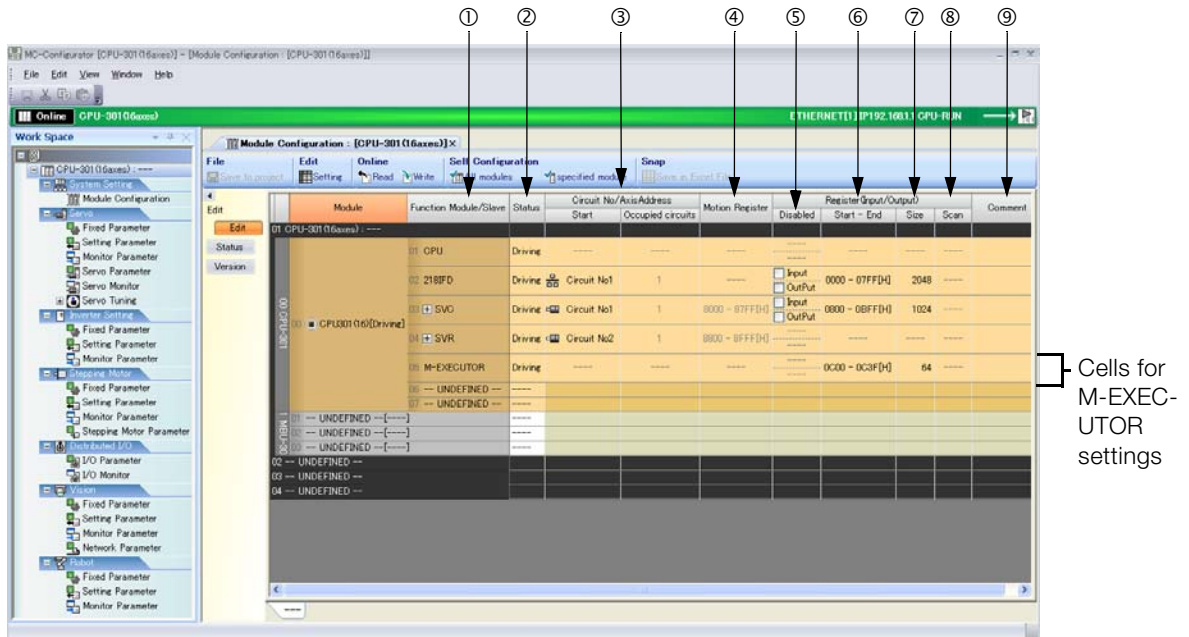

The following table describes the M-EXECUTOR items that are displayed on the Module Configuration Tab Page.

No.	Item	Display/Setting Item	Editing	
①	Function Module/Slave	Displays whether the M-EXECUTOR is enabled. • UNDEFINED: Disabled • M-EXECUTOR: Enabled	Possible	
②	Status	Displays the status of the M-EXECUTOR.	Possible	
③	Circuit No./ Axis Address	Start Occupied circuits	Not used. “----” is always displayed.	Not possible
④	Motion Register	Not used. “----” is always displayed.	Not possible	
⑤	Disabled	Not used. “----” is always displayed.	Not possible	
⑥	Start- End	Displays the range of registers that is used as the I/O area. • Setting range: 00000 to 07FFF hex or 10000 to 17FFF hex Refer to the following section for details. ◆ Details on the I/O Registers on page 3-58	Possible	
⑦	Register (Input/ Output)	Size	The size of the I/O area is displayed in words. • Setting range: 64 to 128 Four words each of input registers and output registers are required to register a single motion program or sequence program in the M-EXECUTOR. If you need to register more than 16 programs, set the size with four additional words for each program to add. A maximum of 32 programs can be registered (maximum number of program definitions).	Possible
⑧	Scan	Not used. “----” is always displayed.	Not possible	
⑨	Comment	Display the user comment. Enter a comment of up to 16 characters.	Possible	

◆ Details on the I/O Registers

The I/O registers that are assigned to the M-EXECUTOR are used to execute motion and sequence programs, as well as to monitor sequence programs.

The following tables give the contents of the M-EXECUTOR I/O registers.

M-EXECUTOR Input Registers

M-EXECUTOR Input Register	Item	
IW□□□□ + 0	Definition No. 1	Status
IW□□□□ + 1		Reserved.
IW□□□□ + 2		Reserved.
IW□□□□ + 3		Reserved.
IW□□□□ + 4	Definition No. 2	Status
IW□□□□ + 5		Reserved.
IW□□□□ + 6		Reserved.
IW□□□□ + 7		Reserved.
⋮	⋮	⋮
IW□□□□ + 3C	Definition No. 16	Status
IW□□□□ + 3D		Reserved.
IW□□□□ + 3E		Reserved.
IW□□□□ + 3F		Reserved.
IW□□□□ + 40	Definition No. 17	Status
IW□□□□ + 41		Reserved.
IW□□□□ + 42		Reserved.
IW□□□□ + 43		Reserved.
⋮	⋮	⋮
IW□□□□ + 7C	Definition No. 32	Status
IW□□□□ + 7D		Reserved.
IW□□□□ + 7E		Reserved.
IW□□□□ + 7F		Reserved.

M-EXECUTOR Output Registers

M-EXECUTOR Output Register	Item	
OW□□□□ + 0	Definition No. 1	Program Number
OW□□□□ + 1		Control Signals
OW□□□□ + 2		Override
OW□□□□ + 3		Reserved.
OW□□□□ + 4	Definition No. 2	Program Number
OW□□□□ + 5		Control Signals
OW□□□□ + 6		Override
OW□□□□ + 7		Reserved.
⋮	⋮	⋮
OW□□□□ + 3C	Definition No. 16	Program Number
OW□□□□ + 3D		Control Signals
OW□□□□ + 3E		Override
OW□□□□ + 3F		Reserved.
OW□□□□ + 40	Definition No. 17	Program Number
OW□□□□ + 41		Control Signals
OW□□□□ + 42		Override
OW□□□□ + 43		Reserved.
⋮	⋮	⋮
OW□□□□ + 7C	Definition No. 32	Program Number
OW□□□□ + 7D		Control Signals
OW□□□□ + 7E		Override
OW□□□□ + 7F		Reserved.

◆ Detail Definition Dialog Box

The Detail Definition Dialog Box has two tab pages, the Program Definition Tab Page and the Allocation Control Register Tab Page.

Use the following procedure to display the Detail Definition Dialog Box.

1. Click the **Module Configuration** Icon on the Start Tab Page.
2. Double-click the  Button in row 05 of the **Function Module/Slave** Column.

■ Program Definition Tab Page

Register the motion or sequence programs to execute.

This section describes the items that are displayed on the Program Definition Tab Page.

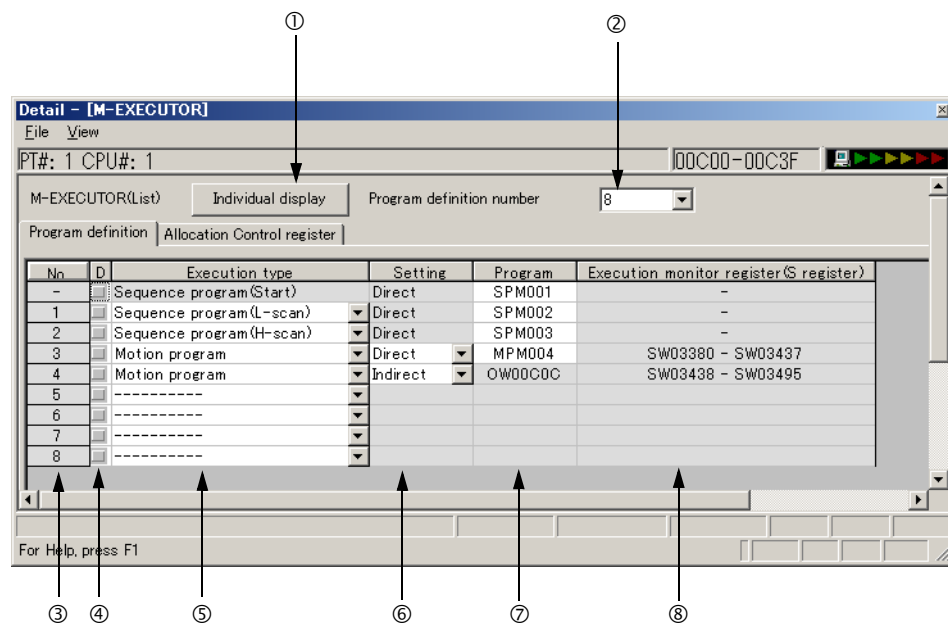

① Individual Display Button

Click this button to display the Program Execution Registration Dialog Box.

② Program Definition Number

Set the number of program definitions that can be registered in the M-EXECUTOR.

- Setting range: 0 to 32
- Default value: 8

③ No.

The execution order of the programs is displayed. Programs are executed in the scans in ascending order of their numbers.

④ D

Enable or disable the definitions.

- Not selected: Definition is enabled.
- Selected: Definition is disabled.

⑤ Execution Type

Set the execution type of the program.

Execution Type	Executed Programs	Execution Condition
-----	Not supported.	–
Startup sequence program	Sequence programs	Startup (These programs are executed once when the power supply is turned ON.)
L-scan sequence program		Started at a fixed interval. (These programs are executed once every low-speed scan cycle.)
H-scan sequence program		Started at a fixed interval. (These programs are executed once every high-speed scan cycle.)
Motion program	Motion programs	Request for Start of Program Operation control signal (The program is executed when the Request for Start of Program Operation is turned ON.)

⑥ **Setting**

Set the program designation method.

The designation method can be different for each program.

Designation Method	Motion Programs	Sequence Programs	Description
Direct designation	Possible	Possible	The program is specified with the program number. Examples: MPM001 or SPM002
Indirect designation	Possible	Not possible	The program is specified by specifying a register that contains the program number. Example: OW0C0C (If 1 is stored in OW0C0C, MPM001 will be called.)

⑦ **Program**

Set the program number.

Execution Type	Description
Sequence programs (Startup, L-scan, or H-scan)	If you enter <i>1</i> and press the Enter Key, SPM001 will be set automatically. You can specify a program that is not registered or leave the program number empty. In either case, no program will be executed.
Motion programs	Direct designation: If you enter <i>1</i> and press the Enter Key, MPM001 will be set automatically. You can specify a program that is not registered or leave the program number empty. In either case, no program will be executed. Indirect designation: The O register of the M-EXECUTOR Module will be set automatically. Only the system can set this.

⑧ **Execution Monitor Registers (S Registers)**

If the execution type is set to a motion program, the range of the execution monitor registers (S registers) will be displayed. Refer to the following section for details on the execution monitor registers.

 ◆ *Motion Program Execution Information on page 4-36*

■ Allocation Control Register Tab Page

This tab page is used to assign registers.

This section describes the items that are displayed on the Allocation Control Register Tab Page.

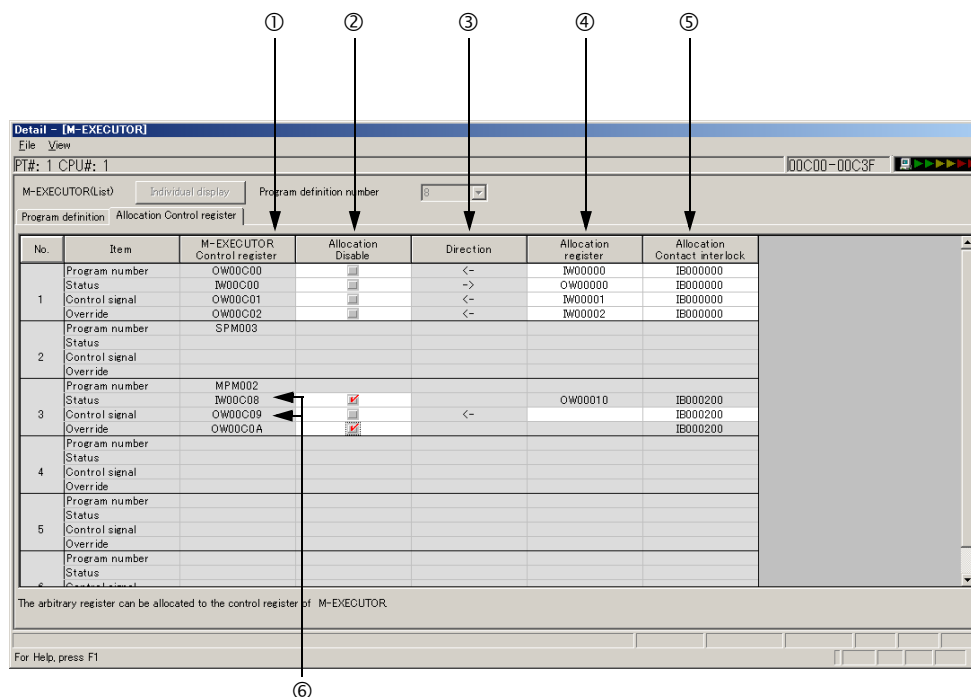

① M-EXECUTOR Control Registers

This column displays the I/O registers that are assigned to the M-EXECUTOR. The M-EXECUTOR control registers are used to control or monitor the motion programs.

M-EXECUTOR Control Register	Application
Program Number	Sets the program number. This register is only used for indirect designation.
Status	Monitors the program execution status.
Control Signals	Controls the program.
Override	Sets the override value to use when executing interpolation motion instructions.

② Allocation Disable

Use these check boxes to enable or disable the assigned registers.

- Not selected: Definition is enabled.
- Selected: Definition is disabled.

③ Direction

This column displays the data I/O directions.

④ Allocation Register

Data is copied between the assigned registers and the M-EXECUTOR control registers according to the arrow in the **Direction** Column (③). You can assign any registers.

Information You can set word-type I, O, or M registers (except motion registers) in the Allocation register Column.

⑤ Allocation Contact Interlock

This contact controls copying data between the assigned registers and the M-EXECUTOR control registers. When the assigned interlock contact is ON, the data in the assigned registers and the M-EXECUTOR control registers is copied in the direction that is given by the arrow in the **Direction** Column (③).

Any register bit number can be assigned as the interlock contact.

Information You can set bit-type I, O, S, M, or C registers (except motion registers) in the Allocation Contact interlock Column.



The assigned interlock contact is used to interlock motion program operation. If you assign a register, always assign an assigned interlock contact.

Important

⑥ Status and Control Signal Details

Double-click the **Status** or the **Control signal** cell to display the Detail Dialog Box. This dialog box is used to verify the status and the control signals.

- Status

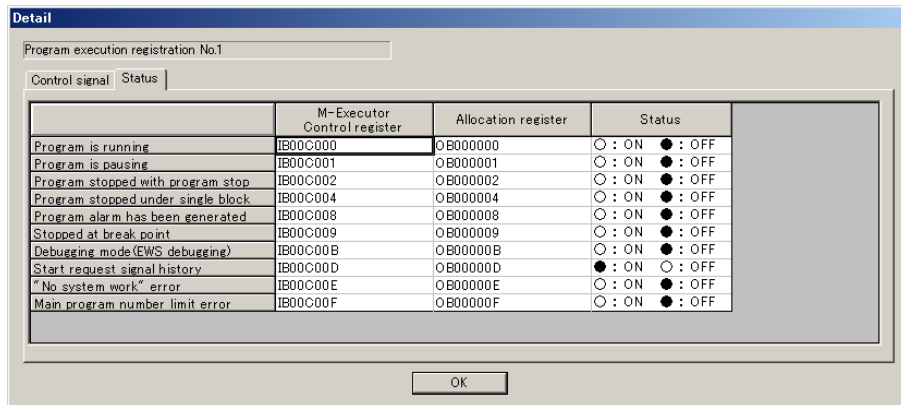

	M-Executor Control register	Allocation register	Status
Program is running	IB00C000	OB000000	○ : ON ● : OFF
Program is pausing	IB00C001	OB000001	○ : ON ● : OFF
Program stopped with program stop	IB00C002	OB000002	○ : ON ● : OFF
Program stopped under single block	IB00C004	OB000004	○ : ON ● : OFF
Program alarm has been generated	IB00C008	OB000008	○ : ON ● : OFF
Stopped at break point	IB00C009	OB000009	○ : ON ● : OFF
Debugging mode(EWS debugging)	IB00C00B	OB00000B	○ : ON ● : OFF
Start request signal history	IB00C00D	OB00000D	● : ON ○ : OFF
"No system work" error	IB00C00E	OB00000E	○ : ON ● : OFF
Main program number limit error	IB00C00F	OB00000F	○ : ON ● : OFF

- Control Signals

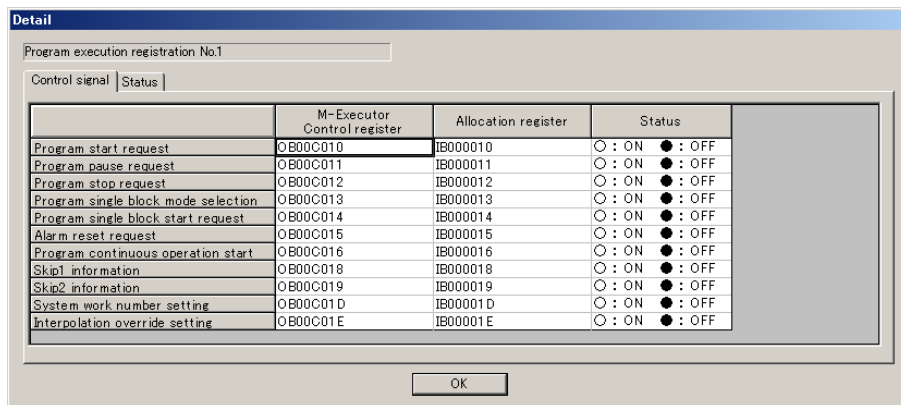

	M-Executor Control register	Allocation register	Status
Program start request	OB00C010	IB000010	○ : ON ● : OFF
Program pause request	OB00C011	IB000011	○ : ON ● : OFF
Program stop request	OB00C012	IB000012	○ : ON ● : OFF
Program single block mode selection	OB00C013	IB000013	○ : ON ● : OFF
Program single block start request	OB00C014	IB000014	○ : ON ● : OFF
Alarm reset request	OB00C015	IB000015	○ : ON ● : OFF
Program continuous operation start	OB00C016	IB000016	○ : ON ● : OFF
Skip1 information	OB00C018	IB000018	○ : ON ● : OFF
Skip2 information	OB00C019	IB000019	○ : ON ● : OFF
System work number setting	OB00C01D	IB00001D	○ : ON ● : OFF
Interpolation override setting	OB00C01E	IB00001E	○ : ON ● : OFF

Creating Motion Programs

Refer to the following manual for details.

MP3000 Series Motion Programming Manual (Manual No.: SIEP C880725 14)

Registering Program Execution

This section gives the procedure to register the execution of programs.

1. Display the program to register for execution.
2. Click the **Task Allocation** () icon.

The Task Allocation Dialog Box will be displayed.

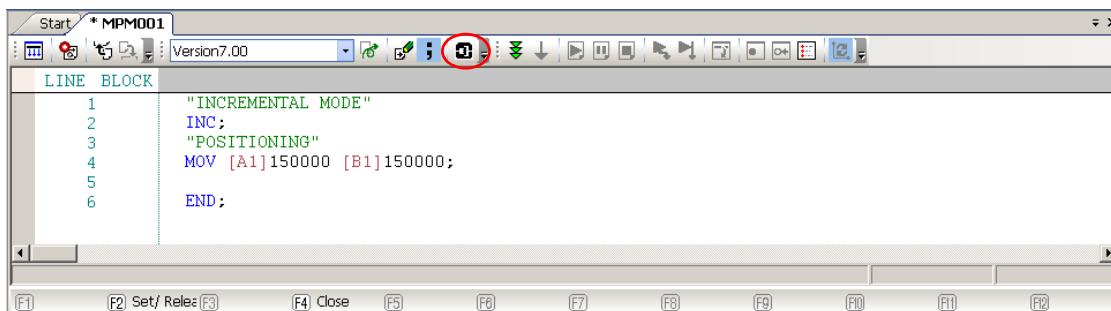

Information

You can also use the Task Allocation Dialog Box to change the settings. Refer to the following manual for details.

 MP3000 Series Motion Programming Manual (Manual No.: SIEP C880725 14)

3. Check that the settings match the contents of the Allocation Control Register Tab Page, and then click the **Set** Button.
The registered contents will be saved.

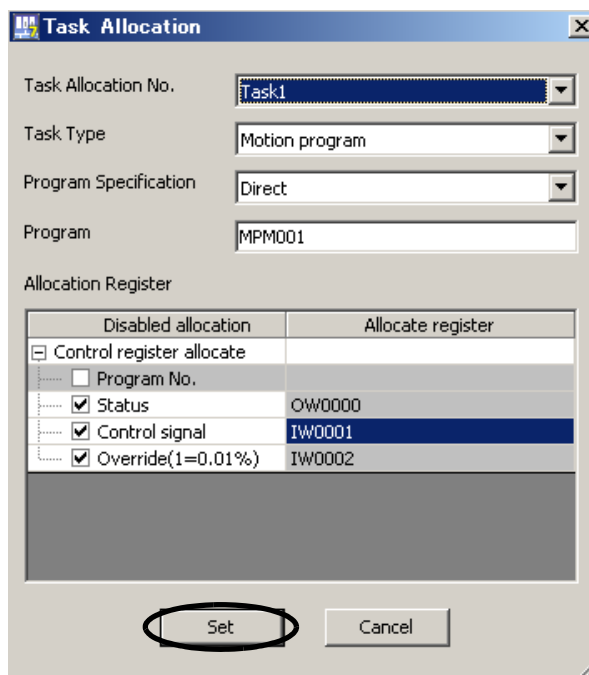

Refer to the following section for details on the Allocation Control Register Tab Page.

 **Allocation Control Register Tab Page** on page 3-61

Execution Scheduling

Programs that are registered in the M-EXECUTOR are executed in the order of their priority levels (execution types).

Programs that are registered in the M-EXECUTOR are executed immediately before processing the ladder programs.

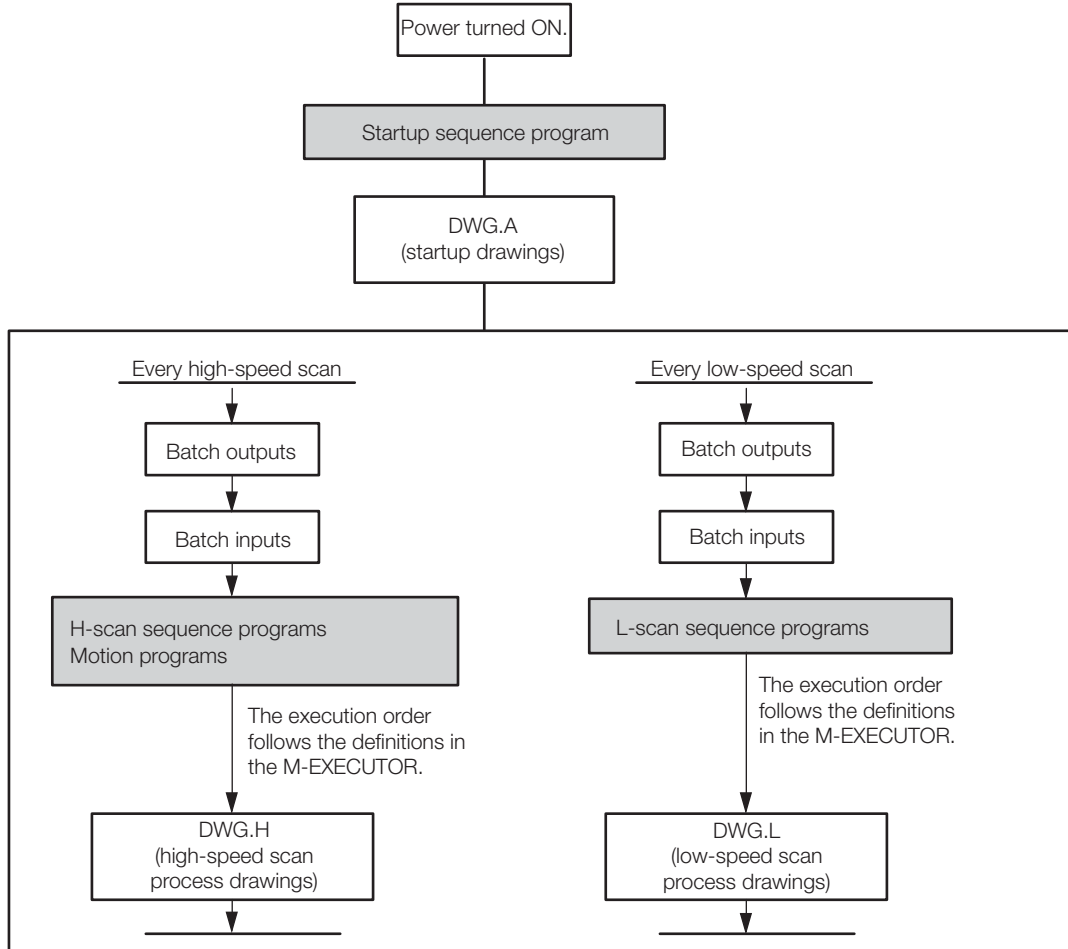

The following is an execution example.

- M-EXECUTOR Program Execution Definitions

Example

Sequence Program Execution Example

The following figure shows an example of the sequence programs registered in the M-EXECUTOR.

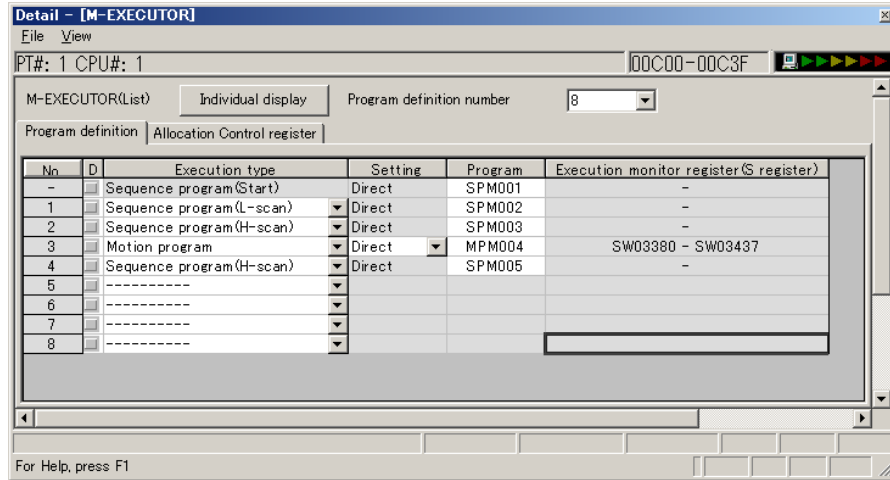

■ Execution Timing

This section describes the execution timing of programs in the above example.

The following figure shows program and drawing execution that is based on the order of registration in the M-EXECUTOR program definitions.

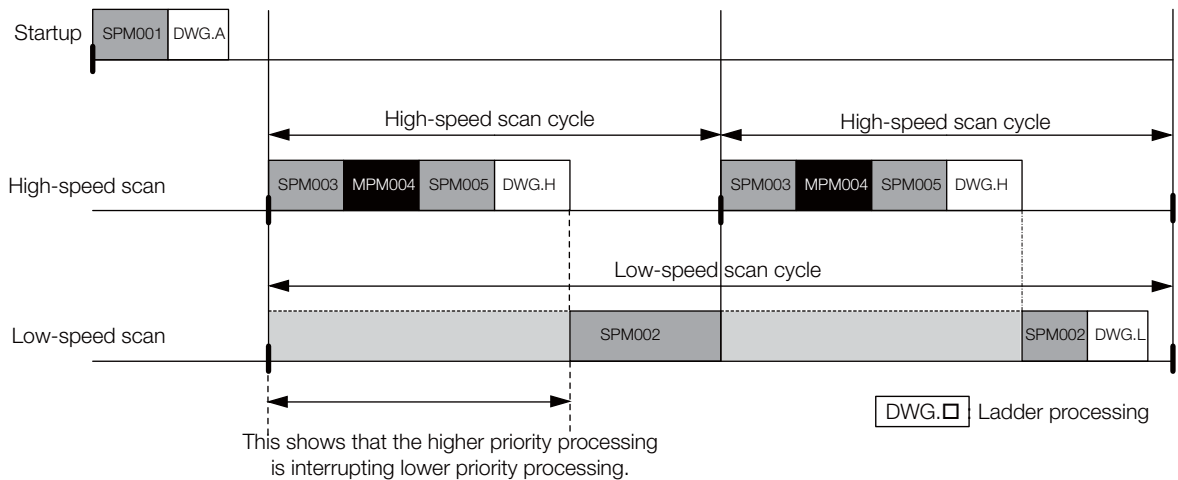

3.2.5 Data Logging

Data logging saves the values of specified registers in a log file according to the preset trigger timing and conditions.

The data is stored in the RAM in the CPU Module, on the USB memory device, or on the FTP server.

Data Storage Location	Merits	Demerits
CPU Module RAM	The file writing speed is fast and the overhead that is placed on the scan is low.	<ul style="list-style-type: none"> Data is lost when the power supply to the CPU Module is turned OFF. Storage capacity is limited (version 1.43 or lower: 8 MB, version 1.44 or higher: 64 MB).
USB memory	<ul style="list-style-type: none"> Data can be stored for a long time. Logged data can be viewed easily by inserting the USB memory device into a PC. 	The file writing speed is slow and the overhead that is placed on the scan is high.
FTP server	Logged data can be viewed easily with a PC without inserting a USB memory device into the PC.	

Operating Procedure

This section describes how to perform data logging.

Information

Refer to the following section for configuring logging settings from tools other than the MPE720.

 *Preparations When Configuring Logging Settings from Tools Other Than the MPE720* on page 3-77

This section describes the operating procedure for data logging using the MPE720.

1. Connect the Machine Controller to the PC, and start the MPE720.
Refer to the following manual for details.
 MP3000 Series Machine Controller System Setup Manual (Manual No.: SIEP C880725 00)
2. Select **View – System** from the menu bar.
The System Pane will be displayed on the left side of the window.
3. Click the **Expand [+]** Button next to the **Logging** item to display the log files in the System Pane and double-click **Logging1**.

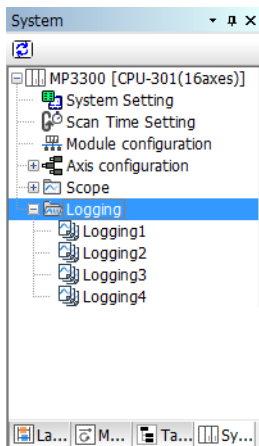

The Logging 1 Dialog Box will be displayed.

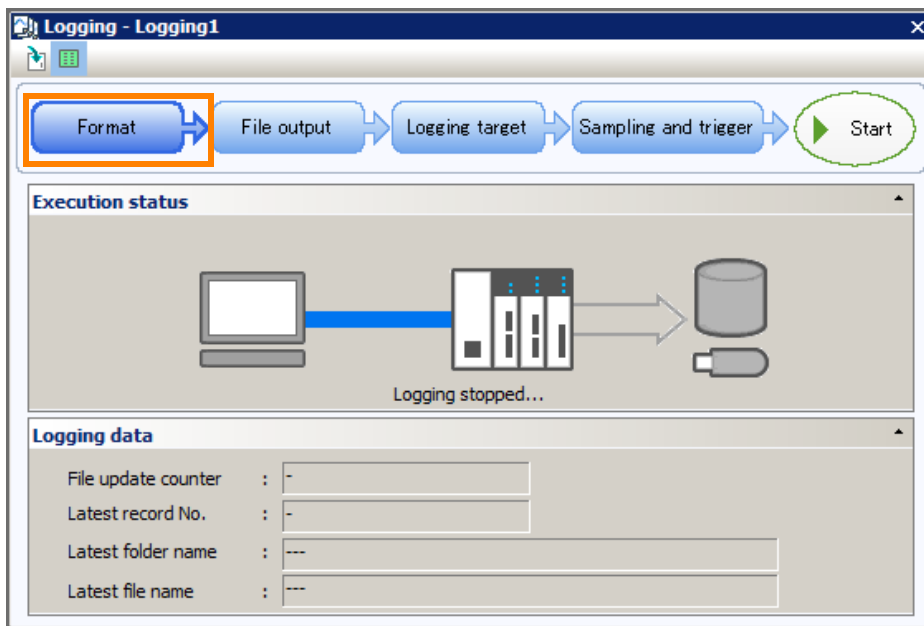
4. Click the **Format** Button.

The Format Dialog Box will be displayed.

5. Set the format.

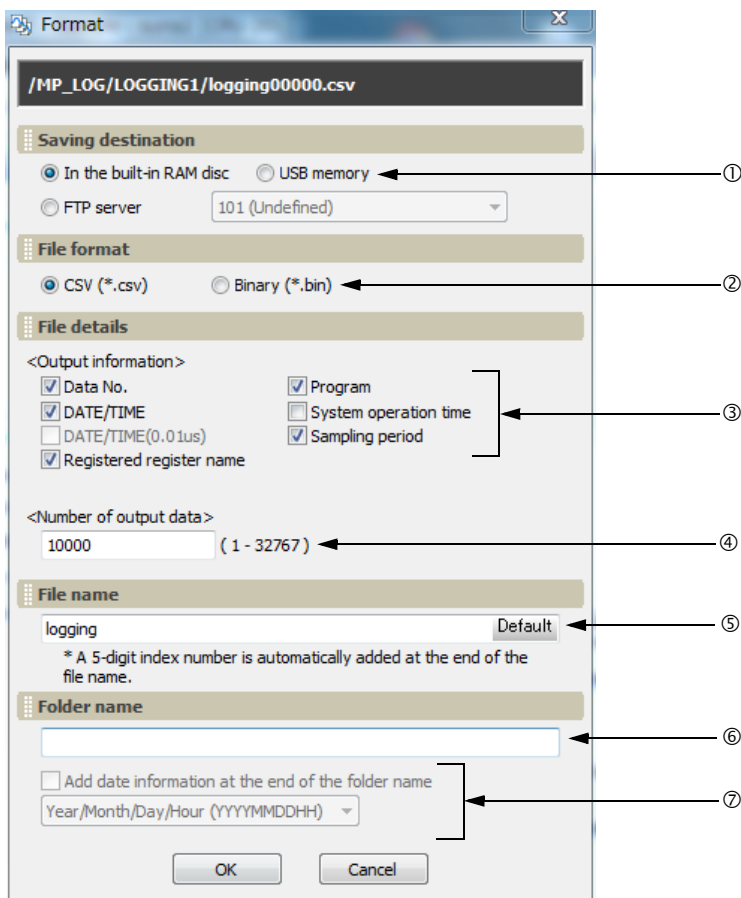

① Select the storage location.

Setting	Description
In the built-in RAM disk	Writes the sampled data to the built-in RAM disk in the CPU Module.
USB memory	Writes the sampled data to the USB memory device in the CPU Module.
FTP server	Writes the sampled data to the FTP server specified by the FTP client settings. Refer to the following section for FTP client settings.  ■ Setting Procedure for Log Data Transfer on page 3-97

② Select the file format.

Setting	Description
CSV	This file format can be opened in general-purpose applications such as Excel and Notepad.
Binary	This file format is not affected by the range of character codes. Binary files are smaller than CSV files, so they can be written faster and with less overhead on the scan.

③ Select the file information to output.

The selected items are appended to the header information in the output file.

Setting	Description
Data No.	The number that is assigned to the sampled data
DATE/TIME	Date and time when the data was sampled (unit: sec.)
DATE/TIME(0.01us)	Date and time when the data was sampled (unit: 0.01 μs)
Registered register name	Name of the register
Programs	Program name
System operation time	System operation time when the data was sampled (unit: μs) Refer to the following section for details.  3.2.9 Calendar on page 3-101
Sampling period	The frequency at which data was sampled Set this in the Sampling and Trigger Dialog Box that is explained later in this section.

④ Enter the number of data items to output.

Enter the number of lines to write to a single file.

- Setting range: 1 to 32,767

⑤ Set the file name.

- Characters allowed: Alphabet A to Z and a to z, numerals 0 to 9, the minus sign, and the underscore.
- Maximum string length: 32 characters

- Information**
1. A five-digit index number that starts from 00001 is automatically added to the end of the specified file name.
 2. Click the **Default** Button to enter “logging”.

⑥ Set the name of the folder to create.

- Characters allowed: Alphabet A to Z and a to z, numerals 0 to 9, the minus sign, and the underscore.
- Maximum string length: 32 characters*

* If you select **Year/Month/Day/Hour (YYYYMMDDHH)** in step ⑦, the maximum string length will be 31.

- Information** If this box is left blank, a folder will not be created. Instead, the file will be created in the root directory of the specified storage location.

- ⑦ Select whether to add date information to the folder name.
- To omit date information, clear the selection of the check box.
 - To add date information, select the check box and select the date format from the list.

Setting	Description
Year (YYYY)	Adds the year to the specified folder name. Example: □□□2011
Year/Month (YYYYMM)	Adds the year and month to the specified folder name. Example: □□□201109
Year/Month/Day (YYYYMMDD)	Adds the year, month, and day to the specified folder name. Example: □□□20110920
Year/Month/Day/Hour (YYYYMMDDHH)	Adds the year, month, and day to the specified folder name and creates another folder directly below it named with the hour. Example: □□□20110920 └─ 12 The sampled data is stored in this folder.

Information Click the **Cancel** Button to return to the Logging 1 Dialog Box without registering the settings.

6. Click the **OK** Button.
The Format Dialog Box closes.
7. Click the **File output** Button in the Logging 1 Dialog Box.
The File Output Dialog Box will be displayed.
8. Set the file output settings.

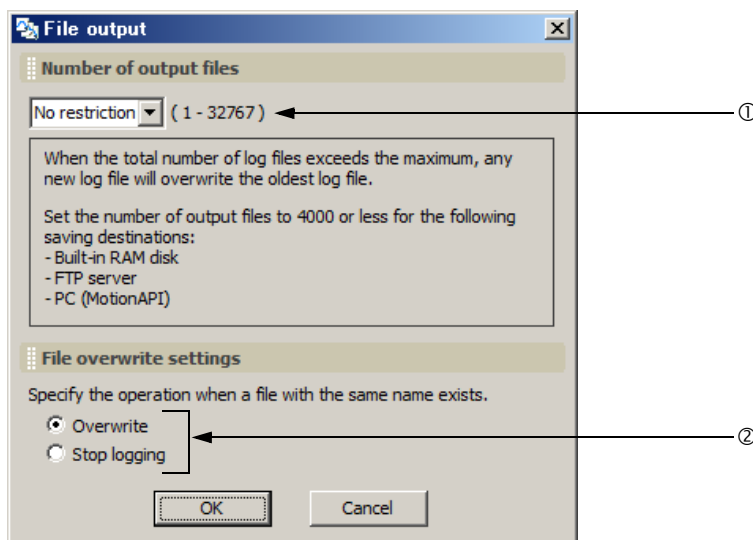

- ① Set the number of output files (total number of files that are created from when the power supply is turned ON to when it is turned OFF).
- Settings: No restriction, 1, 10, 50, 100, 500, or 1,000
You can also input values directly.

Note: 1. If you specify **No restriction** when the saving destination is a USB memory device, the upper limit will be 10,000 files. If you want to output 10,001 or more files, directly input the desired value.

2. If you specify **No restriction** when the saving destination is other than a USB memory device, the upper limit will be 32,767 files.

- ② Set the file overwrite settings.

Setting	Description
Overwrite	When the file number reaches the upper limit on the specified number of output files, older files will be deleted to allow the creation of new files.
Stop logging	When the file number reaches the upper limit of the specified number of output files, logging will stop.

Information Click the **Cancel** Button to return to the Logging 1 Dialog Box without registering the settings.

9. Click the **OK** Button.
The File Output Dialog Box closes.
10. Click the **Logging target** Button in the Logging 1 Dialog Box.
The Logging Target Dialog Box will be displayed.
11. Add the registers to log.

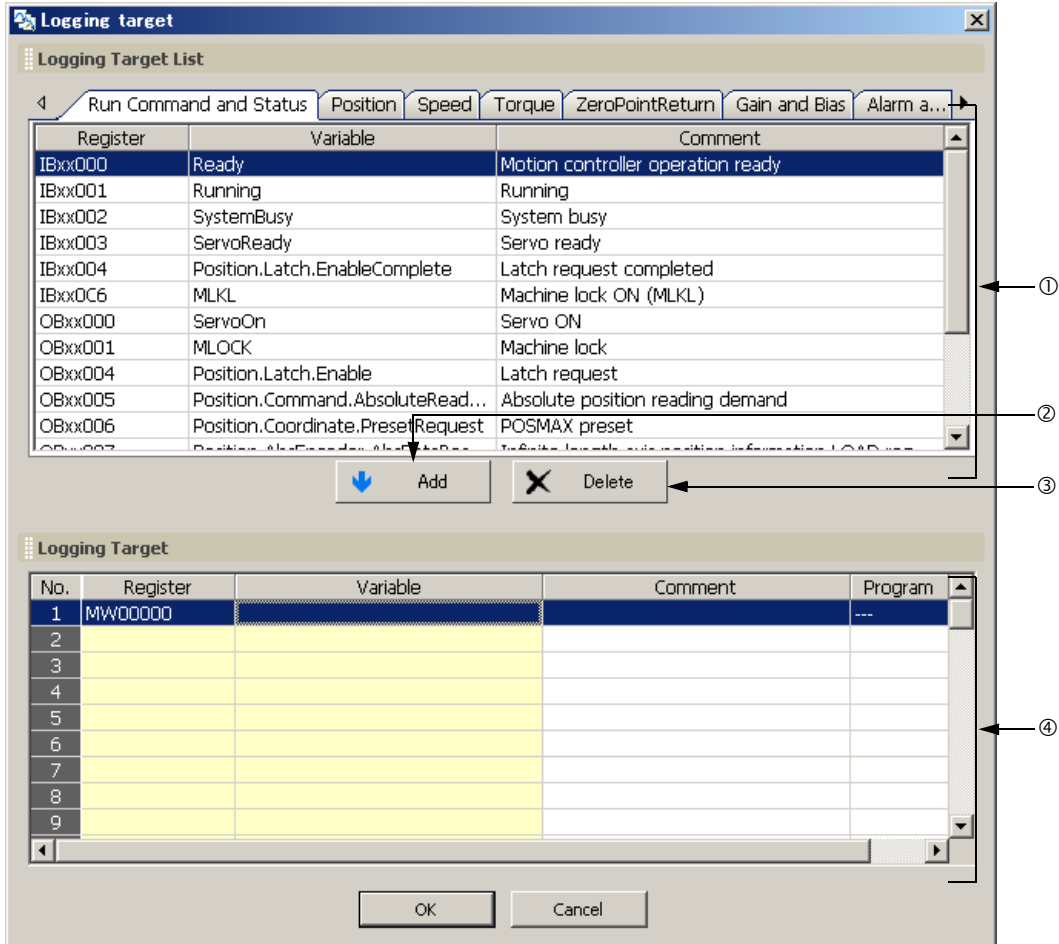

No.	Item	Description
①	Logging Target List	Displays a list of the registers that can be selected for logging. <ul style="list-style-type: none"> • Right-click in the Logging Target List to display the pop-up menu to select or deselect registers. Add to Trace adds the selected register to the Trace Target List. Clear deselects multiple registers that were selected by using the Shift or the Ctrl Keys. Select All selects all registers shown on the tab page.
②	Add Button	Adds the selected register to the list of registers to be logged.
③	Delete Button	Removes the selected registers from the list of registers to be logged.
④	Logging Target	Displays a list of the registers that will be logged. Registers can be added to this list either by selecting them from the Logging Target List or by entering them directly. <ul style="list-style-type: none"> • Right-click in the Logging Target Area to display a pop-up menu to edit the registers to be logged. Insert Row inserts a blank row. Delete Row deletes a row. If a logging target was added, then it will be deleted.

Information The following register types can be logged.

- S, M, G, I, O, and D registers

Information Refer to the following table for the data size for each data type.

Data Type	Data Size
B: bit	1 word
W: integer	1 word
L: double-length integer	2 words
Q: quadruple-length integer	4 words
F: single-precision real number	2 words
D: double-precision real number	4 words

Information Click the **Cancel** Button to return to the Logging 1 Dialog Box without registering the settings.

12. Click the OK Button.

The Logging Target Dialog Box closes.

13. Click the Sampling and trigger Button in the Logging 1 Dialog Box.

The Sampling and Trigger Dialog Box will be displayed.

14. Set the sampling and trigger settings.

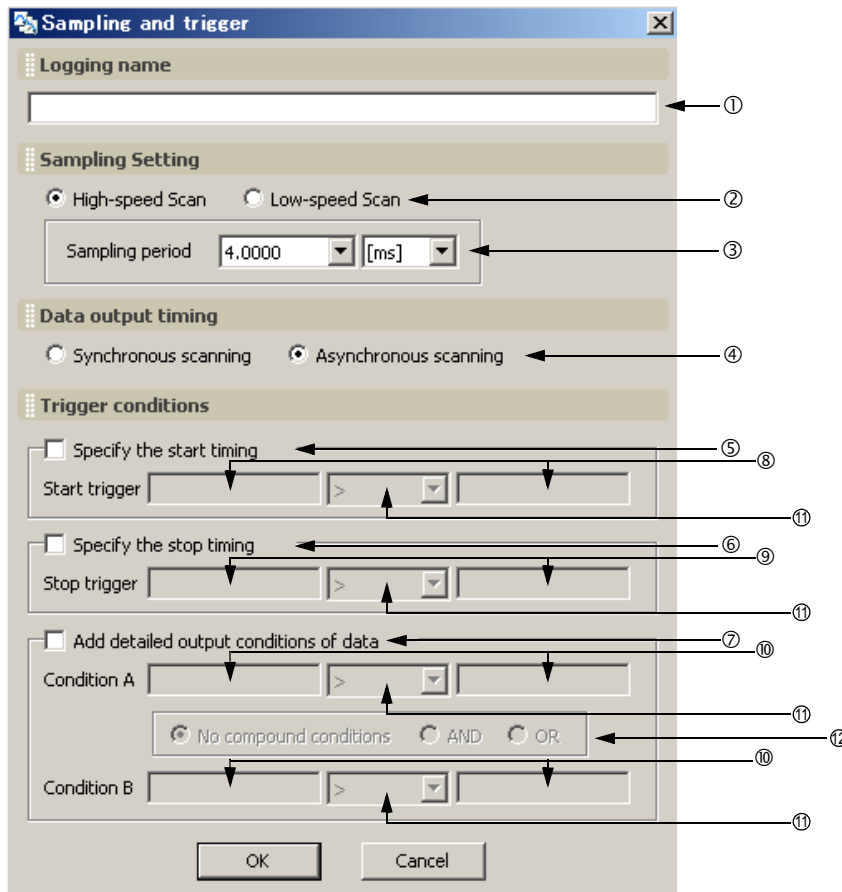

- ① Set the logging name.
 - Maximum name length: 32 characters
- ② Set the data sampling rate.

Setting	Description
High-speed scan	Samples data synchronized with the high-speed scan. Data is sampled immediately after completing execution of the DWG.H ladder program.
Low-speed scan	Samples data synchronized with the low-speed scan. Data is sampled immediately after completing execution of the DWG.L ladder program.

③ Set the data sampling period.

Specify the value and unit to control whether data is sampled every scan or once in more than one scan.

To sample data every scan, specify the same value as the scan set value.

④ Specify whether data is to be logged synchronized or asynchronous with the scan.

Setting	Description	Merits	Demerits
Synchronous scanning	Data is written to the log synchronized with the scan	No data is lost.	This creates an overhead on the scan and can cause Watchdog Errors (E.001), or cause the CPU Module to go down.
Asynchronous Scanning	Data is written to the log asynchronously with the scan.	There is no overhead on the scan.	If the scan setting is set to a fast rate or if the idle time of the scan is low, logging can fall behind or data can be missed if there are too many data points to sample.

Refer to the following section for guidelines on scan settings.

 Scan Setting Guidelines on page 3-75

Information Due to the large overhead, **Synchronous scanning** cannot be set if **USB memory** is set as the **Saving destination** on the Format Dialog Box.

⑤ to ⑩ Set the logging conditions.

No.	Item	Description
⑤	Specify the start timing	If the check box is selected, register operation will control when logging starts. If conditions are set in items ⑥ and ⑩, logging will start when these conditions are met. If the check box is cleared, logging will start according to manual operation of the button displayed by the MPE720.
⑥	Specify the stop timing	If the check box is selected, register operation will control when logging stops. If conditions are set in items ⑤ and ⑩, logging will stop when these conditions are met. If the check box is cleared, logging will stop according to manual operation of the button displayed by the MPE720.
⑦	Add detailed output conditions of data	<ul style="list-style-type: none"> If no detailed output conditions are specified: Clear the check box. If detailed output conditions are specified: Select the check box and specify the conditions for items ⑥, ⑦, and ⑩. Logging will start when these conditions are met. Even if logging stops when the output conditions are no longer met, it will start when the conditions are met again.
⑧	Start condition	Specify any S, M, G, I, or O register, and numeric value. The start condition is when the rising edge is detected (when the register changes from OFF to ON).
⑨	Stop condition	The stop condition is detected by the state of the register. (If the register is ON, the condition is always detected.)
⑩	Condition A and Condition B	Specify any S, M, G, I, or O register and numeric value. If a condition is entered for both condition A and condition B, specify the condition at (⑩).

Continued on next page.

Continued from previous page.

No.	Item	Description														
⑪	Condition	Select one of the following operators.														
		<table border="1"> <thead> <tr> <th>Setting</th> <th>Description</th> </tr> </thead> <tbody> <tr> <td>></td> <td>Condition is met when the left register value is greater than the right register value.</td> </tr> <tr> <td><</td> <td>Condition is met when the left register value is less than the right register value.</td> </tr> <tr> <td>=</td> <td>Condition is met when the left register value is equal to the right register value.</td> </tr> <tr> <td>< ></td> <td>Condition is met when the left register value is not equal to the right register value.</td> </tr> <tr> <td>>=</td> <td>Condition is met when the left register value is greater than or equal to the right register value.</td> </tr> <tr> <td><=</td> <td>Condition is met when the left register value is less than or equal to the right register value.</td> </tr> </tbody> </table>	Setting	Description	>	Condition is met when the left register value is greater than the right register value.	<	Condition is met when the left register value is less than the right register value.	=	Condition is met when the left register value is equal to the right register value.	< >	Condition is met when the left register value is not equal to the right register value.	>=	Condition is met when the left register value is greater than or equal to the right register value.	<=	Condition is met when the left register value is less than or equal to the right register value.
		Setting	Description													
		>	Condition is met when the left register value is greater than the right register value.													
		<	Condition is met when the left register value is less than the right register value.													
		=	Condition is met when the left register value is equal to the right register value.													
		< >	Condition is met when the left register value is not equal to the right register value.													
		>=	Condition is met when the left register value is greater than or equal to the right register value.													
<=	Condition is met when the left register value is less than or equal to the right register value.															
⑫	Compound condition	If a condition is entered for both condition A and condition B, specify one of the following conditions.														
		<table border="1"> <thead> <tr> <th>Setting</th> <th>Description</th> </tr> </thead> <tbody> <tr> <td>No compound condition</td> <td>The compound condition is met when Condition A is met. Condition B will be ignored, even if it is specified.</td> </tr> <tr> <td>AND</td> <td>The compound condition is met when both condition A and condition B are met.</td> </tr> <tr> <td>OR</td> <td>The compound condition is met when either condition A or condition B is met.</td> </tr> </tbody> </table>	Setting	Description	No compound condition	The compound condition is met when Condition A is met. Condition B will be ignored, even if it is specified.	AND	The compound condition is met when both condition A and condition B are met.	OR	The compound condition is met when either condition A or condition B is met.						
		Setting	Description													
		No compound condition	The compound condition is met when Condition A is met. Condition B will be ignored, even if it is specified.													
AND	The compound condition is met when both condition A and condition B are met.															
OR	The compound condition is met when either condition A or condition B is met.															

Example To automatically start logging when the power supply is turned ON, set the Start Trigger to the following condition.

- When the saving destination is set to USB memory:
Setting example: Start trigger SB006540 = ON
Note: The SB006540 register turns ON when a USB memory device is detected.
- When the saving destination is set to built-in RAM disk:
Setting example: Start trigger SB000001 or SB000003 = ON
Note: The SB000001 register turns ON during the first scan of the high-speed scan. The SB000003 register turns ON during the first scan of the low-speed scan.

Example In the following example, the output conditions are set to log only the data in the shaded region.
Setting example: Condition A >= Upper limit, Condition B <= Lower limit, Compound condition = OR

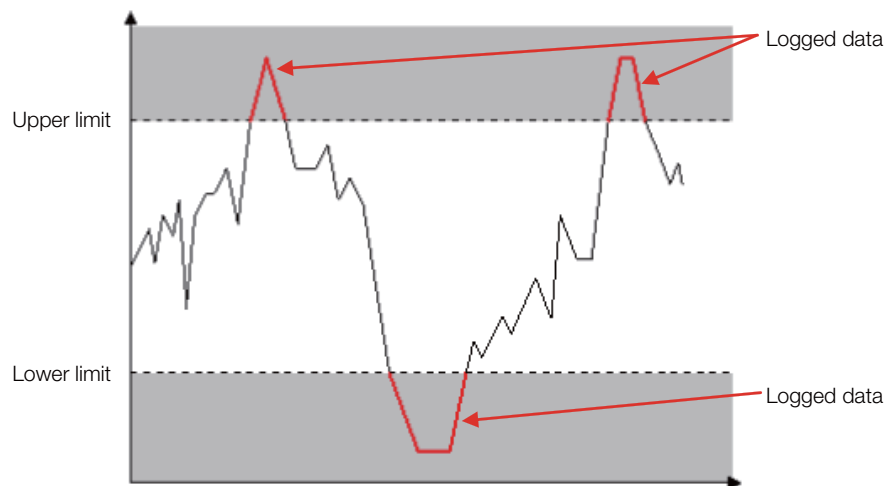

Information Click the **Cancel** Button to return to the Logging 1 Dialog Box without registering the settings.

15. Click the OK Button.

The Sampling and Trigger Dialog Box closed.

16. Click the Start Button in the Logging 1 Dialog Box.

Logging starts. While logging is in progress, the following items are displayed in the Logging 1 Dialog Box.

- File update counter
- Latest record number
- Latest folder name
- Latest file name

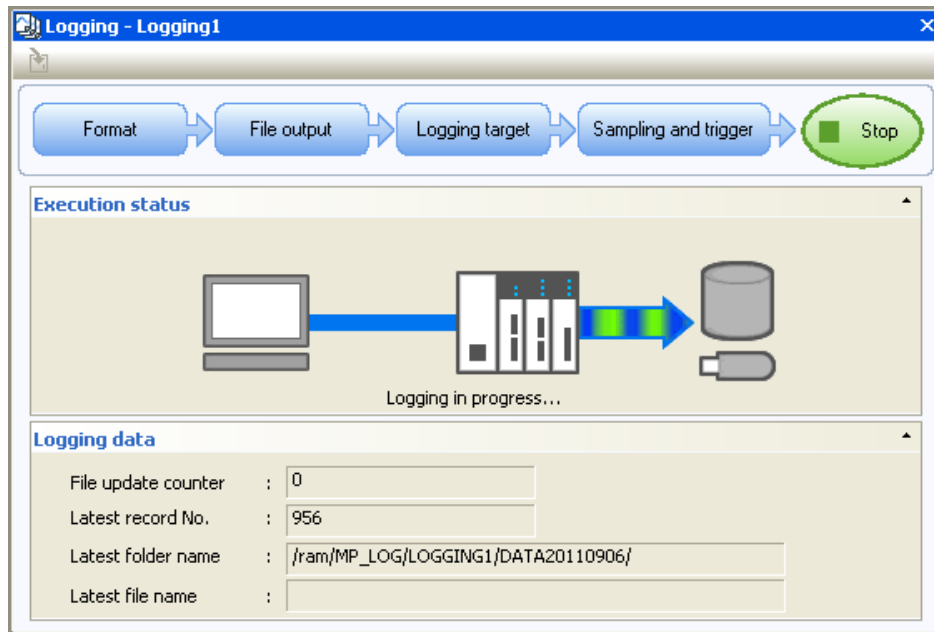

17. Click the Stop Button in the Logging 1 Dialog Box.

Logging will stop.

The following table gives the range of each data and the timing at which logging is reset.

Data Name	Range		Reset Timing
File Name	When the saving destination is set to USB memory	logging00001 to logging10000	The file name resets to logging00001 when the power supply is turned ON. If a file already exists in memory, it will be overwritten.
	When the saving destination is set to built-in RAM disk	logging00001 to logging4000	
Latest record number	0 to 18,446,744,073,709,551,615		The latest record number is reset to 0 when logging starts after a stop.

Scan Setting Guidelines

This section describes guidelines for the scan settings based on when data is logged.

◆ If Logging Is Synchronous with the Scan

The general logging overhead is given below. Set the scan setting to a value that is larger than this value.

Information Due to the large overhead, USB memory cannot be used to log synchronously with the scan.

Model	Saving Destination	General Logging Overhead
CPU-301	Built-in RAM disk	4 ms + 350 μ s \times Number of registered logging targets
	FTP server	Overhead of built-in RAM disk \times 10 or more (Depending on network traffic)
CPU-302	Built-in RAM disk	1.5 ms + 150 μ s \times Number of registered logging targets
	FTP server	Overhead of built-in RAM disk \times 10 or more (Depending on network traffic)

Note: General overhead if logging a double-length integer M register (e.g. ML $\square\square\square\square\square\square$). The overhead varies depending on items such as the register type, data type, and logging output content that is set for logging.



Overhead
The processing or procedure required to perform a certain process or the load on devices and systems for that process or the excess processing time spent on that process.

Term

This timing chart illustrates the logging process when performed synchronously with the scan.

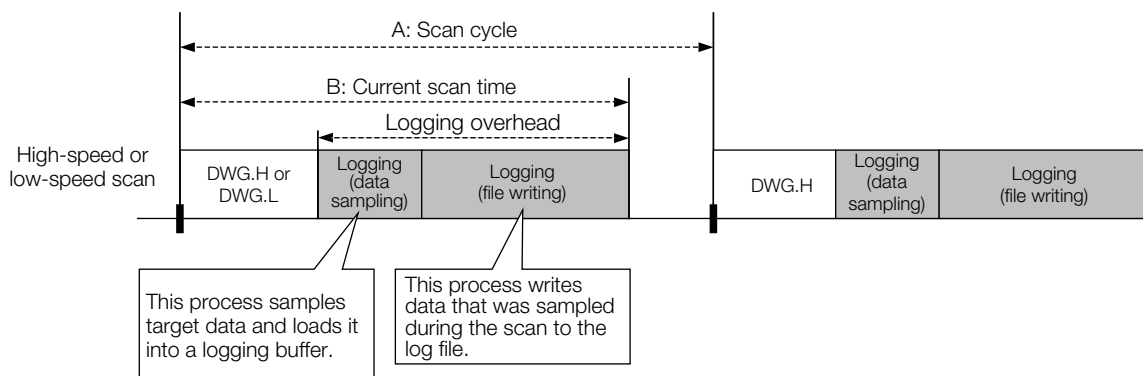

The logging processes for sampling the data and writing it to a file are performed within the scan cycle. Therefore, the scan cycle (time period A in the figure on the previous page), must be set to a value greater than the current scan time (time period B in the figure on the previous page).

If the scan cycle is shorter than the current scan time, a Scan Time Over Limit error will occur and the count of SW00044 (High-speed Scan Over Limit Counter) or SW00046 (Low-speed Scan Over Limit Counter) will be incremented. This can also cause a Watchdog Error (E.001) or cause the CPU Module to go down.

Set the scan time so that it is long enough to log the number of registered data items.

◆ If Logging Is Asynchronous with the Scan

If logging is asynchronous with the scan, data sampling is performed within the scan, but file writing is executed in the background (when scanning is idle). The scan setting should be set as given below.

- Data sampling overhead = $3 \mu\text{s} \times \text{Number of registered logging targets}$
- General scan idle time required for file writing

Saving Destination	General Scan Idle Time
Built-in RAM disk	$0.125 \text{ ms} + 20 \mu\text{s} \times \text{Number of registered logging targets}$
USB memory	$0.5 \text{ ms} + 50 \mu\text{s} \times \text{Number of registered logging targets}$
FTP server	USB memory idle time or more (depending on network traffic)

Note: The general scan idle time provided here applies to the logging process during a high-speed scan when the idle time after a low-speed scan equals or exceeds 20 ms. The required scan idle time varies depending on items such as the register type, data type, and logging output content that is set for logging.

This timing chart illustrates the logging process when performed asynchronously with the scan.

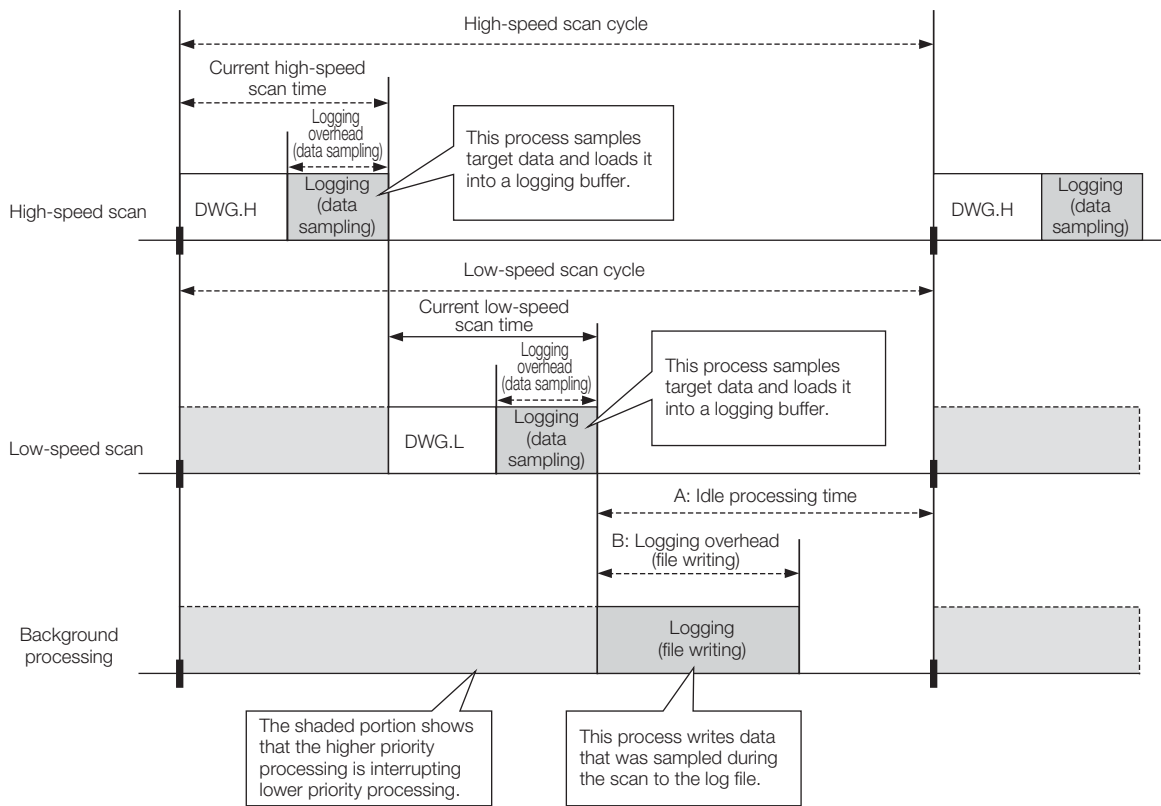

The logging process for sampling the data is performed within the scan, while the process of writing the data to a file is performed in background processing.

The background process is performed during the idle processing time of the scan. Therefore, the idle processing time (time period A in the above figure) must be longer than the logging (file writing) overhead (time period B in the above figure).

If the logging (file writing) overhead time is longer than the idle processing time of the scan, the file writing process can run into the next scan and cause an over limit error (resulting in only some discontinuous data being written to the file). The number of over limit errors can be checked in the over limit counter (SW24008). If an over limit error occurs, take the following actions.

- Increase the set scan time in order to increase the scan idle time. Refer to the following section for details on changing the set scan time.
 - 📖 *Setting the High-speed and Low-speed Scan Times on page 3-32*
- Reduce the amount of data and time required to sample the data at one time.
 - Example 1: Reduce the number of output files in the File Output Dialog Box.
 - Example 2: Reduce the logging targets in the Logging Target Dialog Box.
- Lengthen the time from when logging stops until it starts again.
 - Example: Change the **Trigger conditions** in the Sampling and Trigger Dialog Box.

Monitoring the Logging Execution Status

You can monitor the execution status of data logging by checking the system registers. Refer to the following section for details.

 ◆ *Data Logging Execution Status* on page 4-51

Viewing the Log Data

To view the log data in a PC, the data that is stored in the RAM in the CPU Module or USB memory device must be transferred to the PC. Refer to the following section for details on data transfers.

 ◆ *3.2.7 File Transfer* on page 3-91

Preparations When Configuring Logging Settings from Tools Other Than the MPE720

◆ Introduction

If you enable **Permit Settings from Tools other than MPE720**, you can change the target registers for logging from tools other than the MPE720.

Overhead for logging processing (the processing time for data acquisition and file writing) is added to the regular duration of time required for scanning. When you change the target registers for logging, the maximum value for scan time may exceed the setting value, resulting in the Watchdog Timer Error (E.001) occurring and the CPU shutting down. For this reason, the system is usually configured so that the target registers for logging cannot be changed while operating the machine.

When you use this function, the maximum number of target registers for logging is configured. When you execute logging after configuring the setting, the overhead for logging processing for the configured number of target registers for logging is added to the scan time. Based on this, with the MPE720, you can set the scan time in advance so that this error does not occur. Doing so can prevent an error from occurring when the maximum value for scan time exceeds the setting value, even if you change the target registers for logging from a tool other than MPE720 while operating the machine.

Information To calculate the overhead, perform a simulation at maximum load. The register for logging will be a double-precision real number (4 words) (e.g. SD□□□□□□).
When actually executing the logging function with a tool other than the MPE720, the overhead time may be shorter than calculated.

◆ Setting Procedure

The setting procedure for performing logging setting from a tool other than the MPE720 is described below.

1. Click the **Permit Settings from Tools Other Than MPE720** Icon.

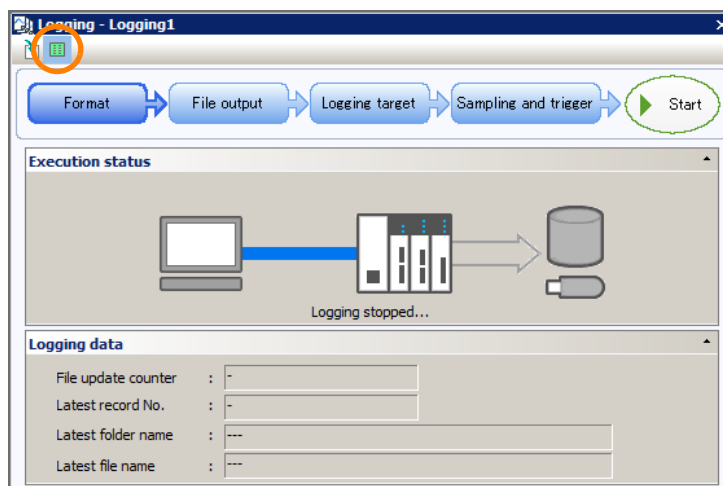

The Permit Settings from Tools Other Than MPE720 Dialog Box will be displayed.

2. Select the check box for **Permit settings from tools other than MPE720**, enter the number of log registers to permit under **Maximum Number of Registers to Log**, and then click the **OK** Button.

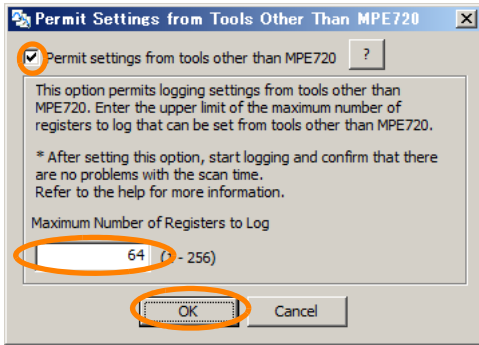

A message will be displayed.

3. Click the **Yes** Button.

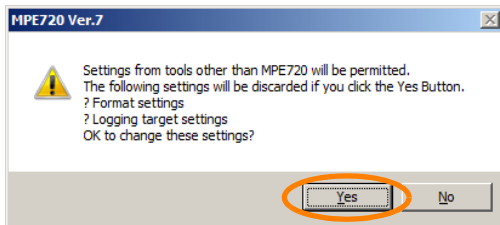

The message will close and the Logging Dialog Box will be displayed.

4. Click **Format**.

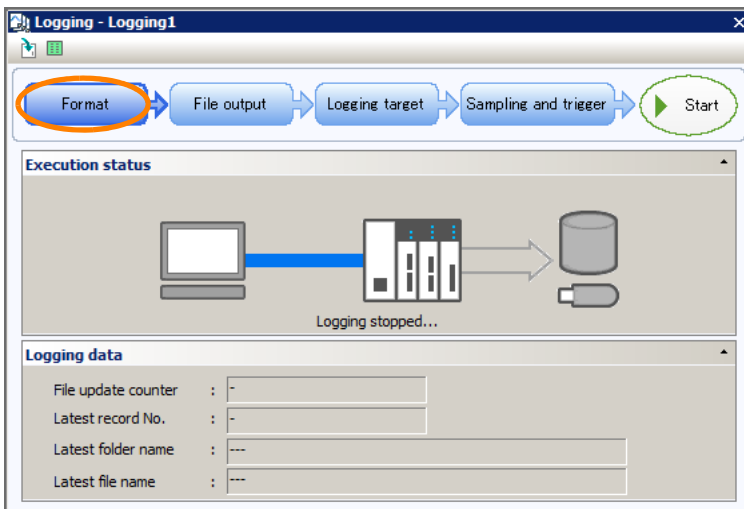

The Format Dialog Box will be displayed.

5. Set the format, and then click the **OK** Button.

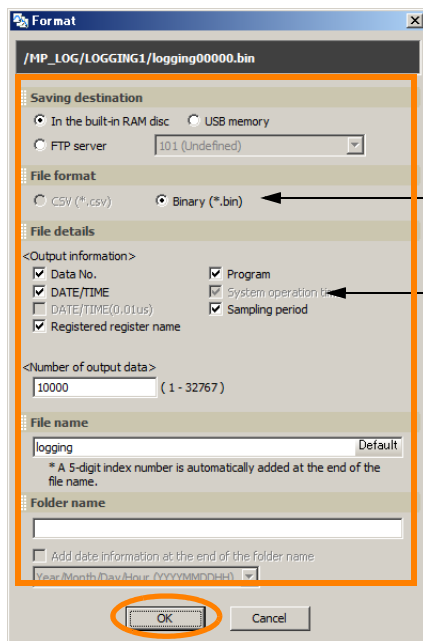

For this setting, it is locked to **Binary (*.bin)**.

For this setting, **System operation time** Check Box cannot be cleared.

Information Settings are the same as those when using the data logging with the MPE720. Refer to the following section for details.

Operating Procedure on page 3-66

The Format Dialog Box will close and the Logging Dialog Box will be displayed.

6. Click **File output**.

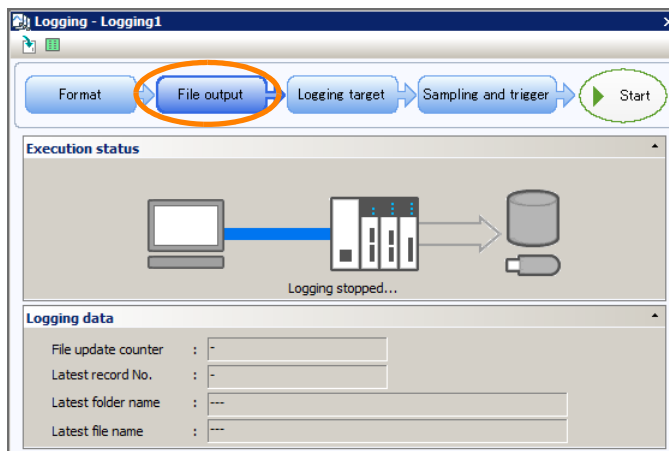

The File Output Dialog Box will be displayed.

7. Set the file output, and then click the **OK** Button.

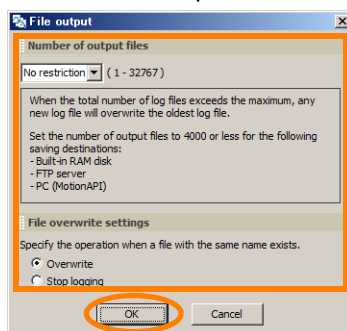

Information Settings are the same as those when using the data logging with the MPE720. Refer to the following section for details.

Operating Procedure on page 3-66

The File Output Dialog Box will close and the Logging Dialog Box will be displayed.

8. Click **Logging target**.

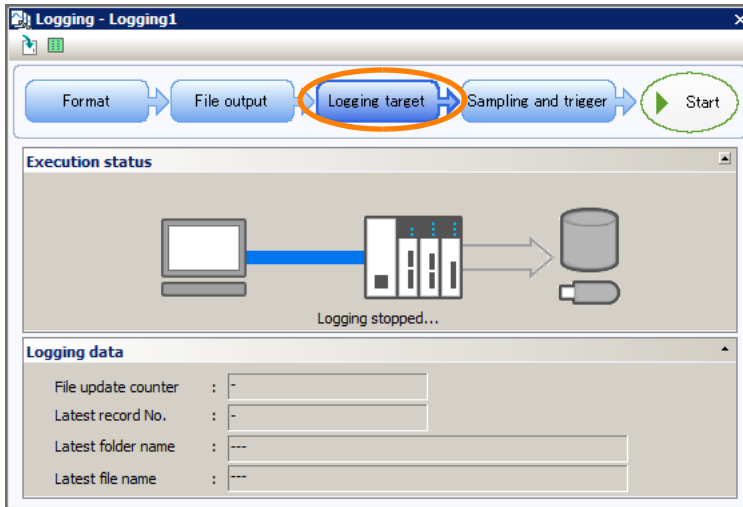

The Logging Target Dialog Box will be displayed.

9. Click the **OK** Button.

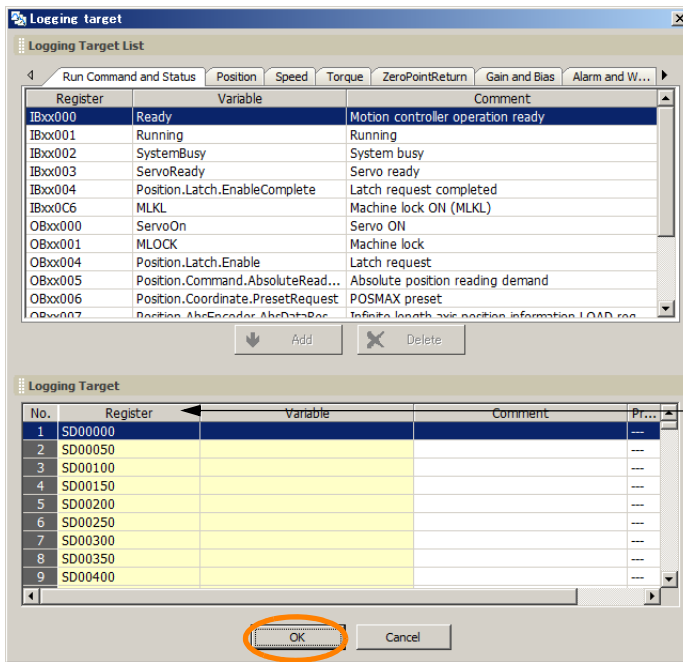

Information As this dialog box is the settings window for simulations, the register cannot be changed. Change registers during actual logging from the actual tool after completing this setting.

The Logging Target Dialog Box will close and the Logging Dialog Box will be displayed.

10. Click **Sampling and trigger**.

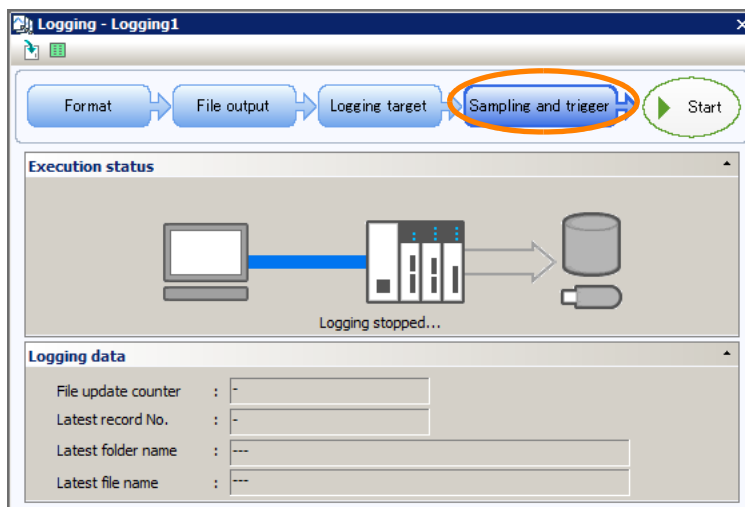

The Sampling and Trigger Dialog Box will be displayed.

11. Set the sampling and trigger, and then click the **OK** Button.

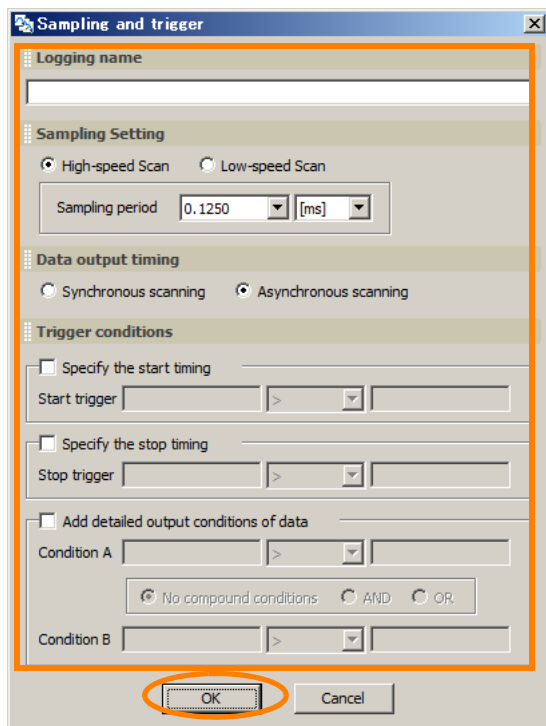

Information Settings are the same as those when using the data logging with the MPE720. Refer to the following section for details.

 *Operating Procedure* on page 3-66

The Sampling and Trigger Dialog Box will close and the Logging Dialog Box will be displayed.

This completes configuration of the settings for logging simulation.

The next steps describe the procedure for executing and checking the results of a logging simulation.

12. Click **Monitor – System monitor** from the Launcher in the MPE720 Window. The System Monitor Dialog Box will be displayed.

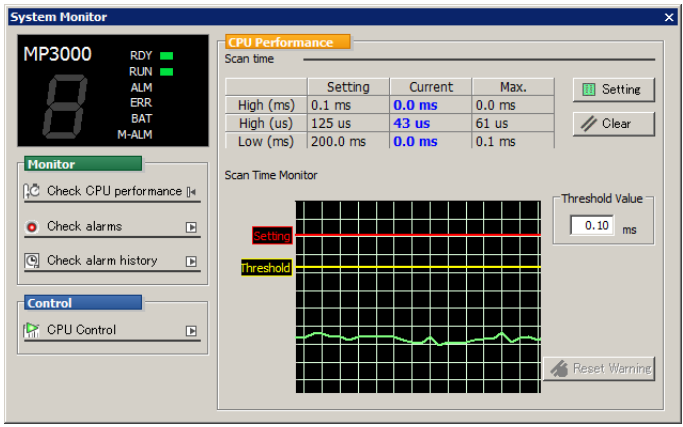

13. Return to the Logging Dialog Box, and click **Start**.

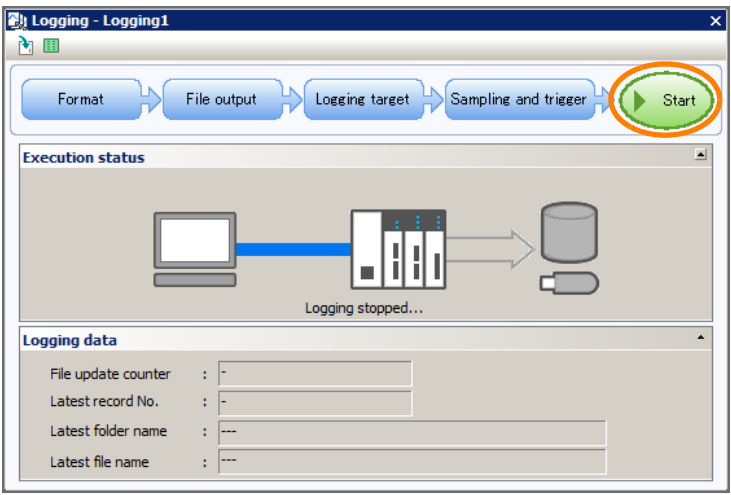

A logging simulation with the conditions you have set will begin.

14. In the System Monitor Dialog Box, check that there is no problem with scan time increment.

<Before Logging Begins>

<After Logging Begins>

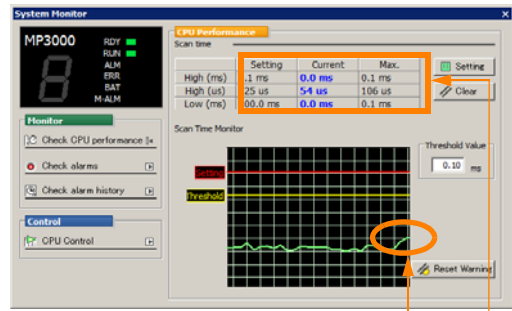
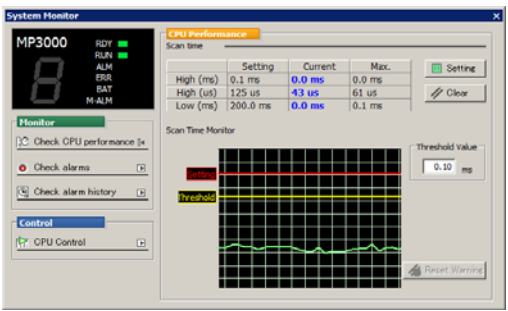

This increment is the overhead from logging.

If the maximum value after logging begins is smaller than the set value, there is no problem.

Information If the scan time exceeds the set value, click the Setting Button in the System Monitor Dialog Box and change the scan time in the dialog box that appears. After you have changed the scan time, click Start in the Logging Dialog Box and perform logging simulation again.

This concludes the settings.

After completing these steps, you can configure logging settings from tools other than the MPE720.

Analyzing Log Data

This section describes how the log data is formatted when viewed on a PC.

◆ CSV File Format

This example shows how log data that is stored in the CSV format appears when it is opened in Microsoft Excel.

①	[HeaderSize]	137	byte					
②	[ScanType]	H-Scan						
③	[ScanTime]	4	ms					
④	[Register]			MW0000	MW0001	GW0000	GW0002	
⑤	[ProgramName]							
⑥		No.	DATE/TIME					
⑦		0	2011/06/23 18:02_19s	15544	0	49992	15544	
		1	2011/06/23 18:02_19s	15545	0	49991	15545	
		2	2011/06/23 18:02_19s	15546	0	49990	15546	
		3	2011/06/23 18:02_19s	15547	0	49989	15547	
		4	2011/06/23 18:02_19s	15548	0	49988	15548	
		5	2011/06/23 18:02_19s	15549	0	49987	15549	
		6	2011/06/23 18:02_19s	15550	0	49986	15550	
		7	2011/06/23 18:02_19s	15551	0	49985	15551	

⑧	[Register]					MW00000	
	[ProgramName]						
		No.	DATE/TIME	SubSeconds(0.01 us)	SYSTEM TIME(us)		
		0	2011/06/23 14:43_04s	94000000	4436000	0	
		1	2011/06/23 14:43_04s	94400000	4440000	0	
⑨		2	2011/06/23 14:43_04s	94800000	4444000	0	

• Header Details

No.	Item	Description	Corresponding Item in MPE720
①	HeaderSize	Gives the size of the header that is appended to the file.	—
②*	ScanType	The type of scan where the data was obtained (high-speed scan or low-speed scan) is displayed.	Sampling period on the Format Dialog Box.
③*	ScanTime	Gives the data sampling period.	
④*	Register	Gives the registers specified in the data settings.	Registered register name on the Format Dialog Box.
⑤*	ProgramName	Gives the program name specified in the data settings.	Program on the Format Dialog Box.
⑥*	No.	Gives the number of the data that was sampled.	Data No. on the Format Dialog Box.
⑦*	DATE/TIME	Gives the date and time when the data was sampled (unit: sec.).	DATE/TIME on the Format Dialog Box.
⑧*	DATE/TIME SubSeconds (0.01us)	Gives the date and time when the data was sampled (unit: 0.01 μs).	DATE/TIME(0.01us) on the Format Dialog Box.
⑨*	SYSTEM TIME(us)	Gives the system operation time when the data was sampled (unit: μs).	System operation time on the Format Dialog Box.

* These items may not be given depending on the settings in the MPE720. Refer to the following section for details.

📖 *Operating Procedure* on page 3-66

◆ Binary File Format

This example shows how log data that was stored in the binary format appears when it is opened in a text editor.

The diagram illustrates the binary file format. On the left, a grid of hexadecimal values is shown, with the first 16 rows highlighted in red. On the right, the corresponding ASCII header is displayed, with three callouts: ① points to the header size field, ② points to the register name field, and ③ points to the program name field.

① Header

The header is given in ASCII characters.

Item	Description	Corresponding Item in MPE720
HeaderSize	Gives the size of the header that is appended to the file.	-
ScanType*	The type of scan where the data was obtained (high-speed scan or low-speed scan) is displayed.	Sampling period on the Format Dialog Box.
ScanTime*	Gives the data sampling period.	
Register*	Gives the registers specified in the data settings.	Registered register name on the Format Dialog Box.
ProgramName*	Gives the program name specified in the data settings.	Program on the Format Dialog Box.
No.*	Gives the number of the data that was sampled.	Data No. on the Format Dialog Box.
DATE/TIME*	Gives the date and time when the data was sampled (unit: sec.).	DATE/TIME on the Format Dialog Box.
DATE/TIME SubSeconds (0.01 us)*	Gives the date and time when the data was sampled (unit: 0.01 μs).	DATE/TIME(0.01 us) on the Format Dialog Box.
SYSTEM TIME	Gives the system operation time when the data was sampled (unit: μs).	System operation time on the Format Dialog Box.

* These items may not be given depending on the settings in the MPE720. Refer to the following section for details.

Operating Procedure on page 3-66

② Bit Pattern of Header Information

③ Register Data

Gives the register data, Data No. and time in little endian. Data size for register data and time varies depending on the content.

- Register Data

Data Type	Data Size
B: bit	2 bytes
W: integer	2 bytes
L: double-length integer	4 bytes
Q: quadruple-length integer	8 bytes
F: single-precision real number	4 bytes
D: double-precision real number	8 bytes

- Data No.
Data Size: 8 bytes

- Time

Item	Data Size	Remarks
DATE/TIME	8 bytes	BCD display
DATE/TIME, SubSeconds (0.01us)	16 bytes	
SYSTEM TIME	8 bytes	-

Example The following example shows how the register data is given for the settings and conditions listed below.

File Details to Output

- **Data No.** and **DATE/TIME** are selected.

Target Register to Log

- MW00000

Status

- Data No.: 000001
- DATE/TIME: 2011/06/23 18:02:19
- Value of MW00000 register: 100

Actual Data

01 00 00 00 00 00 00 00 11 00 23 06 02 18 19 00 64 00

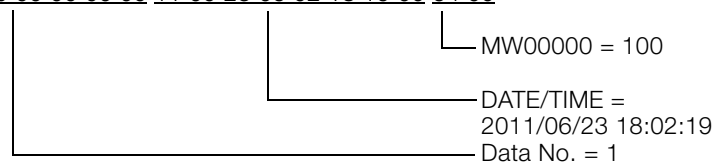

Example The following example shows how the register data is given for the settings and conditions listed below.

File Details to Output

- **Data No.**, **DATE/TIME(0.01us)**, and **System operation time** are selected.

Target Register to Log

- MQ00000

Status

- Data No.: 000001
- DATE/TIME(0.01us): 2011/06/23 15:42:48.476
- System operation time: 358797600000 (0.01 μs)
- Value of MQ00000 register: 123456

Actual Data

Data No. = 1	DATE/TIME(0.01us)
	2011/06/23 15:42 48.476
<u>01 00 00 00 00 00 00 00 11 00 23 06 42 15 00 00 80 81 F0 20 01 00 00 00</u> <u>00 E5 00 8A 53 00 00 00 40 E2 01 00 00 00 00 00</u>	
	MQ00000 = 123456
System operation time = 358797600000 (0.01 μs)	

3.2.6 USB Memory

You can transfer user application data between the RAM in the CPU Module and the USB memory device.

Operation		Description	Reference
USB memory batch transfer	Batch load	Loads all of the user application data that is saved in the USB memory device to the RAM in the CPU Module. The data is also saved to flash memory.	◆ <i>Batch Loading from USB Memory Device</i> on page 3-87
	Batch save	Saves all of the user application data that is saved in the CPU Module's RAM to the USB memory device.	◆ <i>Batch Saving to USB Memory</i> on page 3-88
Data logging		Saves all of the logged data in the CPU Module to the USB memory device.	3.2.7 <i>File Transfer</i> on page 3-91
Import/Export instructions	Batch load	Loads all of the user application data that is saved in the USB memory device to the CPU Module's RAM from within a ladder program.	MP3000 Series Ladder Programming Manual (Manual No.: SIEP C880725 13)
	Batch save	Saves all of user application data that is saved in the CPU Module's RAM to the USB memory device from within a ladder program.	

Operating Procedures

This section describes the procedures for loading all of the data from the USB memory device and saving all of the data to the USB memory device.

◆ Batch Loading from USB Memory Device

1. Turn OFF the power supply to the Base Unit.
2. Insert the USB memory device that contains the application data to transfer into the USB connector on the CPU Module.

Information Make sure that the folder hierarchy and file naming where the application data is to be stored is as shown below.

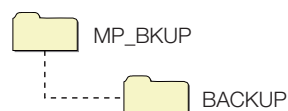

3. Turn ON only the LOAD pin on the mode switches on the CPU Module.

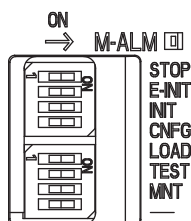

- Set the INIT pin on the mode switches on the CPU Module according to the register type to load.

Registers to Load	INIT Switch Setting	
	OFF	ON
M registers	Transferred.	Not transferred.
G registers	Not transferred regardless of DIP switch setting.	
S registers		
I registers		
O registers		
C registers	Always transferred regardless of DIP switch setting.	
# registers		
D registers		

- Turn ON the power supply to the Base Unit.

The batch load operation starts.

Information

If the load operation fails, an error code will be displayed on the display on the CPU Module. Refer to the following manual to troubleshoot the problem, then perform the batch load again.

📖 MP3000 Series Machine Controller System Troubleshooting Manual (Manual No.: SIEP C880725 01)

The progress of processing will be shown on the display during the batch load operation as follows:

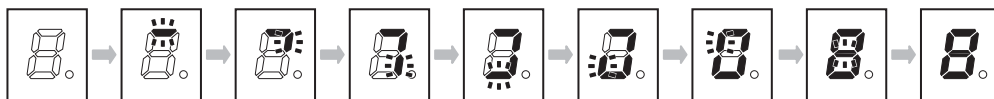

- Turn OFF the power supply to the Base Unit.
- Remove the USB memory device from the USB connector of the CPU module.
- Turn OFF the LOAD pin on the mode switches on the CPU Module.
- Turn ON the power supply to the CPU Module.

◆ **Batch Saving to USB Memory**

Information

When a save operation is performed to the USB memory device, any data that is stored on the USB memory device will be overwritten.

- Turn ON the power supply to the Base Unit.
- Make sure the security password has not been set for the CPU Module. Otherwise, any attempts to perform a batch save will fail. Refer to the following manual for details on the security password.
📖 MP3000 Series Machine Controller System Setup Manual (Manual No.: SIEP C880725 00)
- Insert the USB memory device that contains the application data to save into the USB connector on the CPU Module.

4. Set the INIT pin on the mode switches on the CPU Module according to the register type to save.

Registers to Save	INIT Switch Setting	
	OFF	ON
M registers	Transferred.	Not transferred.
G registers	Transferred.	Not transferred.
S registers	Transferred.	Not transferred.
I registers	Transferred.	Not transferred.
O registers	Transferred.	Not transferred.
C registers	Always transferred regardless of DIP switch setting.	
# registers		
D registers		

5. Press and hold the STOP/SAVE switch on the CPU Module for at least two seconds. The batch save operation starts.

Information If the save operation fails, an error code will be displayed on the display on the CPU Module. Refer to the following manual to troubleshoot the problem, then perform the batch save again.

 MP3000 Series Machine Controller System Troubleshooting Manual (Manual No.: SIEP C880725 01)

The progress of processing will be shown on the display during the batch save operation as follows: The batch save operation has been completed when the normal operation display appears on the display (i.e., the lower right dot will flash).

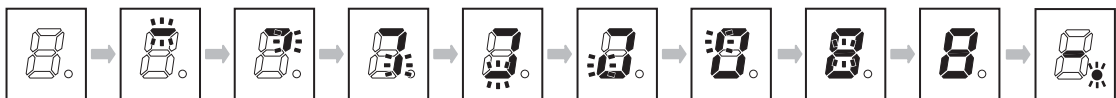

6. Press the STOP/SAVE switch. Confirm that the USB status indicator changes from flashing to not lit and then remove the USB memory.

Information The hierarchy of the folders in which the application data was saved will be as shown below. Only the alarm history file will be in CSV format. It is stored with the following name: ALARM_HISTORY.csv.

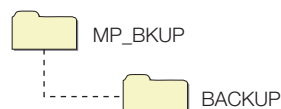

Alarm History File

This section describes the data that is displayed when an alarm history file is checked on a PC.

◆ Format of the Alarm History File

The following example shows how the CSV file is displayed when it is opened in a text editor.

```

No.,Alarm Code,Alarm Detail Format,Date,Rack,Unit,Slot,Detail1,Detail2,Detail3,Detail4,Detail5
1,A101H,I/O error,2000/01/01 00:00_40s,1,0,0,0000H,0000H,0000H,0000H,0000H
2,A30BH,Other error,2000/01/01 00:00_56s,1,0,0,0000H,0000H,0000H,0000H,0000H
    
```

No.	Item	Remarks
①	Index	Range: 1 to 100
②	Alarm Code	Refer to the following manual for details. MP3000 Series Machine Controller System Troubleshooting Manual (Manual No.: SIEP C880725 01)
③	Alarm Detail Format	<ul style="list-style-type: none"> • Operation error • I/O error • Other error
④	Time when alarm occurred	yyyy/mm/dd/ hh:mm_ss
⑤	Alarm Rack Number	–
⑥	Alarm Unit Number	–
⑦	Alarm Slot Number	–
⑧	Alarm Detail 1	Alarm Details The information depends on the alarm details format type (③). <ul style="list-style-type: none"> • Operation Errors <ul style="list-style-type: none"> Alarm detail 1: Error drawing number Alarm detail 2: Referenced drawing number Alarm detail 3: Referenced drawing step number Alarm details 4 and 5: Reserved for system. • I/O error <ul style="list-style-type: none"> Alarm details 1 to 5: Reserved for system. • Other error <ul style="list-style-type: none"> Alarm details 1 to 5: Reserved for system.
⑨	Alarm Detail 2	
⑩	Alarm Detail 3	
⑪	Alarm Detail 4	
⑫	Alarm Detail 5	

3.2.7 File Transfer

Both an FTP server and FTP client are provided for file transfers.

The features of both of these are given in the following table. Use them as best suited to your system.

Item	FTP Server	FTP Client
Overview	Sends data in response to requests from remote FTP clients.	Actively sends data to remote FTP servers.
Remote FTP Clients/Servers	You can set up to five clients.	You can set up to 20 servers.
Data to Transfer	<ul style="list-style-type: none"> Log data Register data 	<ul style="list-style-type: none"> Log data
Transferable Data Size	RAM Version 1.43 or lower: 8 MB, Version 1.44 or higher: 64 MB	
	USB memory (When using the recommended USB memory device): 4 GB	–
Data Update Timing	When a request is received from a remote FTP client	When a log data file is output

FTP Server

The FTP server is provided so that you can transfer data between the RAM in the CPU Module or the USB memory device and a remote device capable of acting as an FTP client.

Data to Transfer	Transfer Direction	Remarks	Reference
Log data	CPU Module to Remote device	–	<i>Operating Procedure on page 3-66</i>
Register data	CPU Module to Remote device	Uses the Export instruction from a ladder program.*	MP3000 Series Ladder Programming Manual (Manual No.: SIEP C880725 13)
	Remote device to CPU Module	Uses the Import instruction from a ladder program.*	

* Can be used for the CPU Module version 1.30 or higher and the MPE720 version 7.39 or higher.



- The full path of the file to be transferred must be within 256 characters including all folder and file names.
- If you transfer too many files at the same time, a 426 error (connection closed; transfer aborted) will occur at the remote device and the files will not be transferred normally. If that occurs, separate the files into more than one transfer and transfer them again.

Information

1. The FTP server supports up to five simultaneous connections.
2. The IP address of the FTP server is the same as the IP address that is set on the 218IFD Detail Definition Dialog Box for the Communications Module. Refer to the following manual for details.
 - 📖 MP3000 Series Communications User's Manual (Manual No.: SIEP C880725 12)

Folder Structure

This section describes the folder structure of the FTP server.

/(FTP ROOT)



Setting Up FTP Accounts

FTP accounts must be set up to allow FTP clients to access the FTP server. This section describes the default settings of an FTP account, and how to change those settings.

◆ Default

The default settings of an FTP account are given below.

User Name	Password	FTP Privileges
USER-A	USER-A	R/W*

* R: Files can be read from the FTP client.
W: Files can be written from the FTP client.

◆ Setting Up FTP Accounts

If you need to change the default settings or add a new FTP account, use the MPE720. You can define up to five FTP accounts.

Use the following procedure.

1. Connect the Machine Controller to the PC, and start the MPE720.
Refer to the following manual for details.
 MP3000 Series Machine Controller System Setup Manual (Manual No.: SIEP C880725 00)
2. Select **File – Environment Setting** from the menu bar.

3. Select **Security** and then **User Registration**.

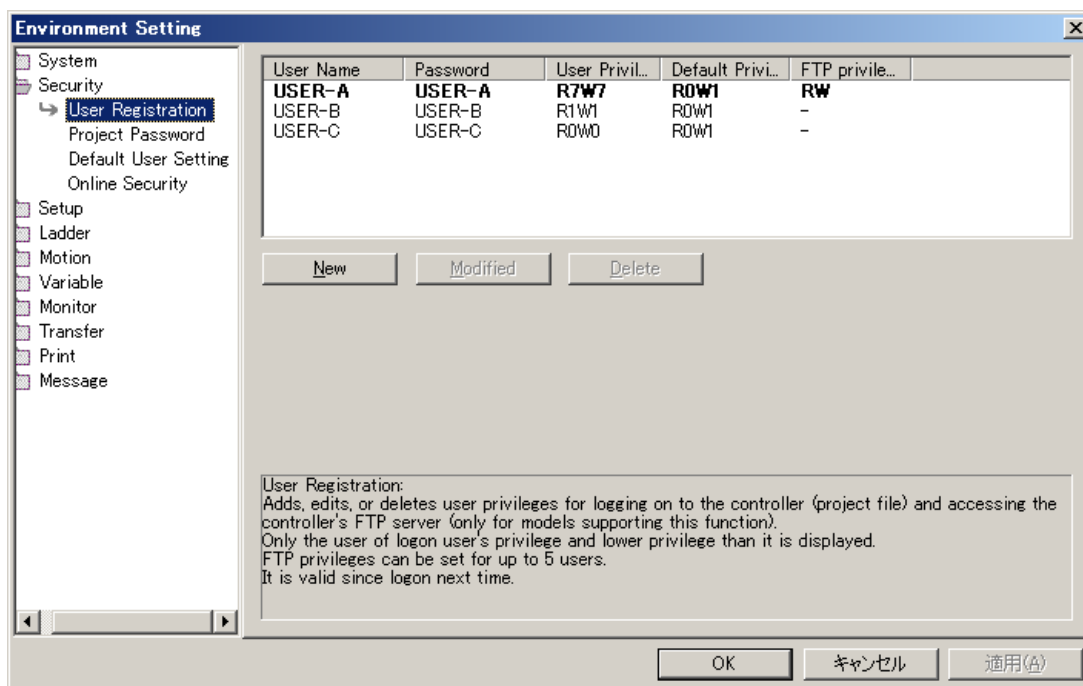

- **Adding a New FTP Account**
 Click the **New** Button.
 The User Registration Dialog Box will be displayed.
- **Changing the Settings of an Existing FTP Account**
 Select the user name for the FTP account to be changed and click the **Modified** Button.
 The User Registration Dialog Box will be displayed.
- **Deleting an Existing FTP Account**
 Select the user name for the FTP account to be deleted and click the **Delete** Button.
 The selected FTP account will be deleted. Proceed to step 5.

4. Set the FTP account information in the User Registration Dialog Box.

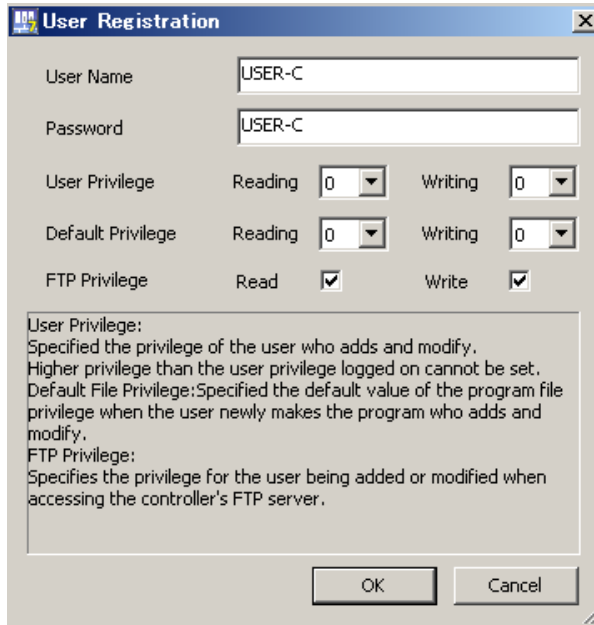

No.	Item	Description	Remarks
①	User Name	This is the name that the FTP client on the remote device must use to log in to perform a file transfer.	<ul style="list-style-type: none"> You can enter up to 16 characters. The string is case sensitive.
②	Password	This is the password that the FTP client on the remote device must use to log in to perform a file transfer.	<ul style="list-style-type: none"> You can enter up to 16 characters. The string is case sensitive.
③	User Privilege	Reserved for system.	Specify 0 for reading and writing.
④	Default Privilege	Reserved for system.	Specify 0 for reading and writing.
⑤	FTP Privilege	This is the file read and write privileges that the FTP client on the remote device will have during file transfers.	<ul style="list-style-type: none"> Refer to the following section for details on the tasks that are affected by the FTP privilege settings. <ul style="list-style-type: none"> ■ <i>FTP Privileges and Applicable FTP Commands</i> on page 3-95 A client cannot be set to writing only.

5. Click the **OK** Button.

6. Log off from the MPE720.
The settings are enabled.

■ FTP Privileges and Applicable FTP Commands

Item	Command	FTP Privileges		Description
		R	R/W	
Connection/ Disconnection	bye	○	○	Disconnects and terminates the connection with the FTP server.
	close	○	○	Disconnects the connection with the FTP server.
	open	○	○	Starts a connection with the FTP server.
	quit	○	○	Disconnects and terminates the connection with the FTP server.
	user	○	○	Enters the user name when logging in to the FTP server.
File/Directory Operations	cd	○	○	Changes the current directory of the FTP server
	delete	×	○	Deletes a file on the FTP server.
	mdelete	×	○	Deletes multiple files on the FTP server.
	dir	○	○	Displays a list of the files in the current directory of the FTP server, including file names, sizes, and last revision dates.
	ls	○	○	Displays a list of the file names in the current directory of the FTP server.
	mkdir	×	○	Creates a directory in the FTP server.
	pwd	○	○	Displays the current directory of the FTP server.
	rename	×	○	Renames a file on the FTP server.
File Transfers	rmdir	×	○	Deletes a directory in the FTP server.
	get	○	○	Downloads a file from the FTP server.
	mget	○	○	Downloads multiple files from the FTP server.
	put	×	○	Uploads a file to the FTP server.
	mput	×	○	Uploads multiple files to the FTP server.

Note: ○: Allowed, ×: Not allowed.

◆ Accessing the FTP Server

This section describes how to access the FTP server from a Windows PC.

1. Enter the address in the address bar.

The address structure is as follows:

ftp://USER-A:USER-A@192.168.1.1

IP address of Machine Controller

Password

User name

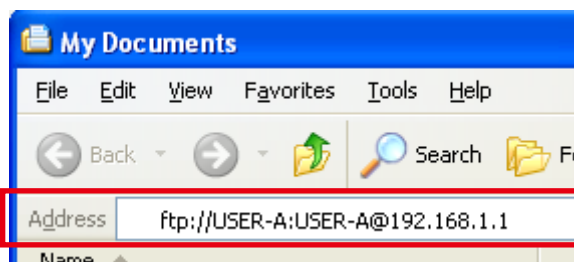

2. Press the **Enter** Key.

The folder of the FTP server will be displayed. That is, the contents of the USB memory device connected to the CPU Module is displayed.

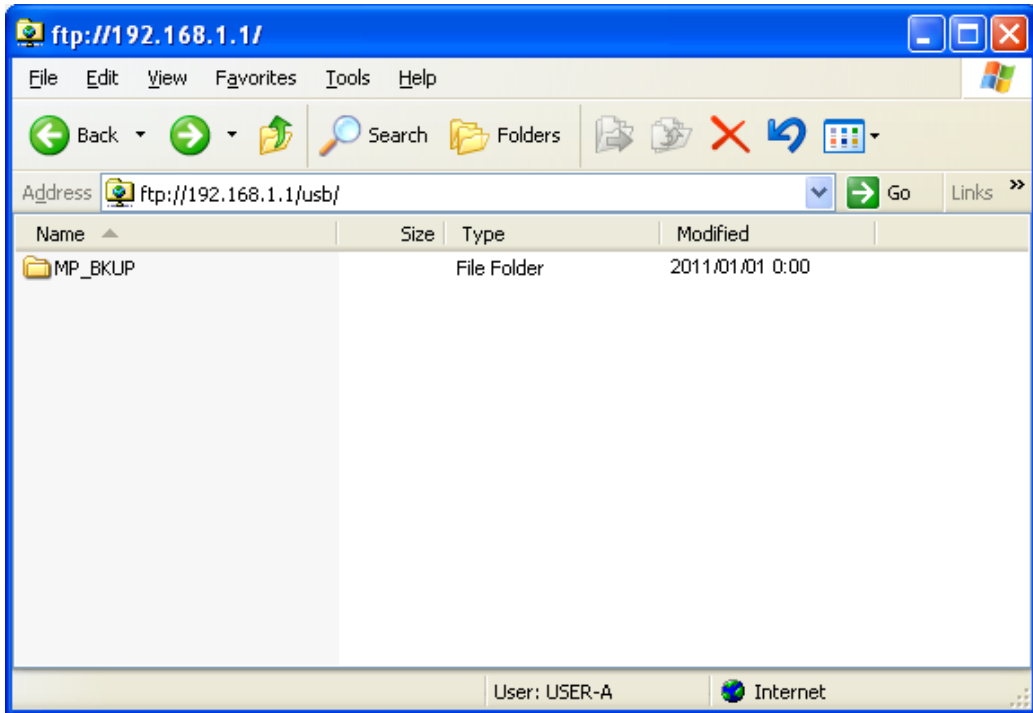

FTP Client

The FTP client is provided so that you can transfer data between the RAM in the CPU Module or the USB memory device and a remote device capable of acting as an FTP server.

No special programming is required to get the log data in the application in the device that provides the FTP server.

Data to Transfer	Transfer Direction	Reference
Log data	CPU Module to Remote device	<i>Operating Procedure</i> on page 3-66

Information

1. You can connect to up to 20 servers at the same time.
2. You can transfer up to 8 MB (version 1.43 or lower) or 64 MB (version 1.44 or higher) when using the RAM in the CPU Module.

◆ Specifications

The specifications of the FTP client are given in the following table.

	Item	Description
Client	IP address	The local IP address of the 218IFD is used.
	Control port number	A port number is automatically assigned.
	Service port number	A port number is automatically assigned.
	Source directory path	The directory path that is specified in the data logging format settings is used. (The built-in RAM is used as a temporary folder.)
	Send file name	The file name that is specified in the data logging format settings is used.
Server	IP address	An IP address is specified.
	Control port number	ACTIV mode: 21 PASV mode: Any port number
	Service port number	ACTIV mode: 20 PASV mode: Any port number
	Number of connected servers	20
	Login user name	Up to 32 alphanumeric characters (case sensitive).
	Login password	Up to 32 alphanumeric characters (case sensitive).
	Directory path	Up to 64 alphanumeric characters (case sensitive, directories separated with slashes).

◆ Procedures to Use the FTP Client

■ Setting Procedure for Log Data Transfer

The FTP client settings are set in the Machine Controller with the MPE720. The data from the files that are output by the logging function are sent to a server.

Use the following procedure to make the settings.

1. Connect the Machine Controller to the PC, and start the MPE720.
Refer to the following manual for details.
📖 MP3000 Series Machine Controller System Setup Manual (Manual No.: SIEP C880725 00)
2. Display the Module Configuration Tab Page and double-click the cell for 218IFD.
3. Set the IP address, subnet mask, and gateway address, and set the local station.

4. Click the **FTP client settings** Button on the My Tool Tab Page.

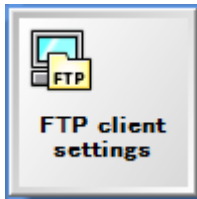

The Environment Setting Dialog Box is displayed. You can set up to 20 FTP servers.

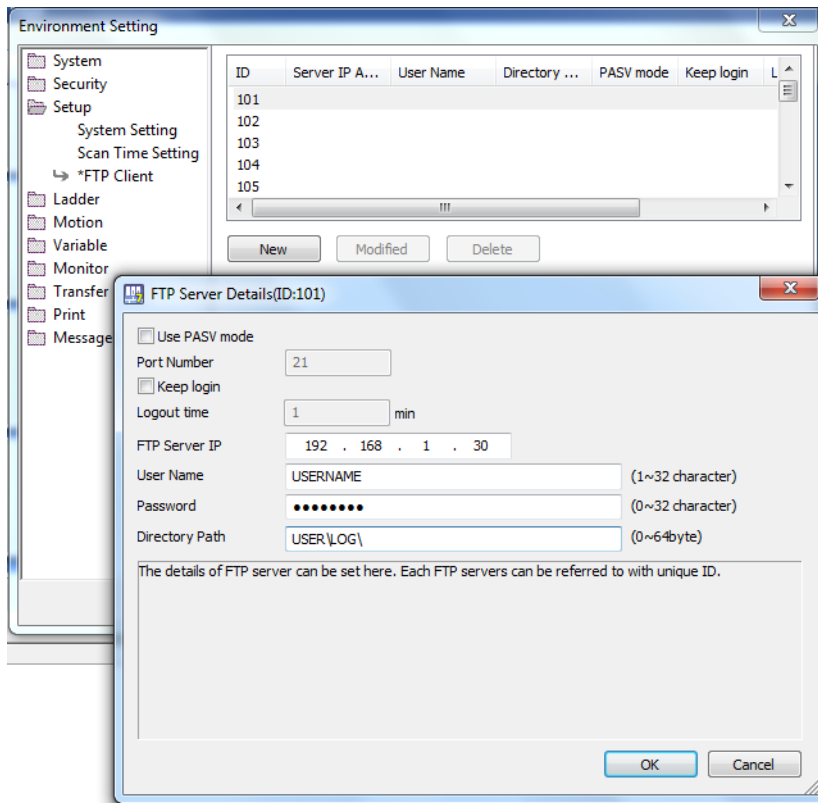

5. Double-click the row for each ID.

The FTP Server Details Dialog Box will be displayed. Refer to the following section for details on the settings.

■ *Details on the FTP Server Details Dialog Box* on page 3-100

6. Make the FTP server settings and then click the **OK** Button.

7. Click the **OK** or **Apply** Button in the Environment Setting Dialog Box.

8. In the Format Dialog Box for the logging 1 or logging 2 settings, select the **FTP server** Option for the saving destination and select the ID number that you set in the FTP Server Details Dialog Box.

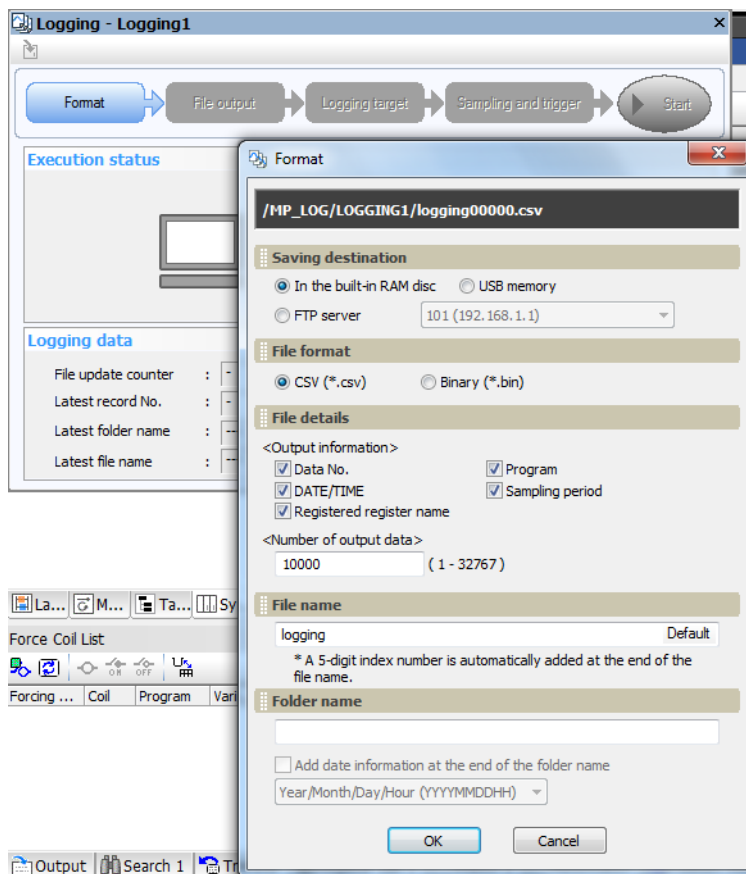

- Note: 1. The file that is set in the **File name** Area will be transferred. It will be written to the FTP server using the same file name.
 2. If you select an FTP server as the destination, the built-in RAM disk that is specified for the folder name is used as a temporary area.

9. Make the other settings for logging.

10. Click **OK** Button.

11. Save the data to flash memory as required.

12. Execute the logging.

When the specified number of output data has been logged and the file is ready, the file will be transferred to the FTP server.

■ Details on the FTP Server Details Dialog Box

The contents of the FTP Server Details Dialog Box are described in the following table.

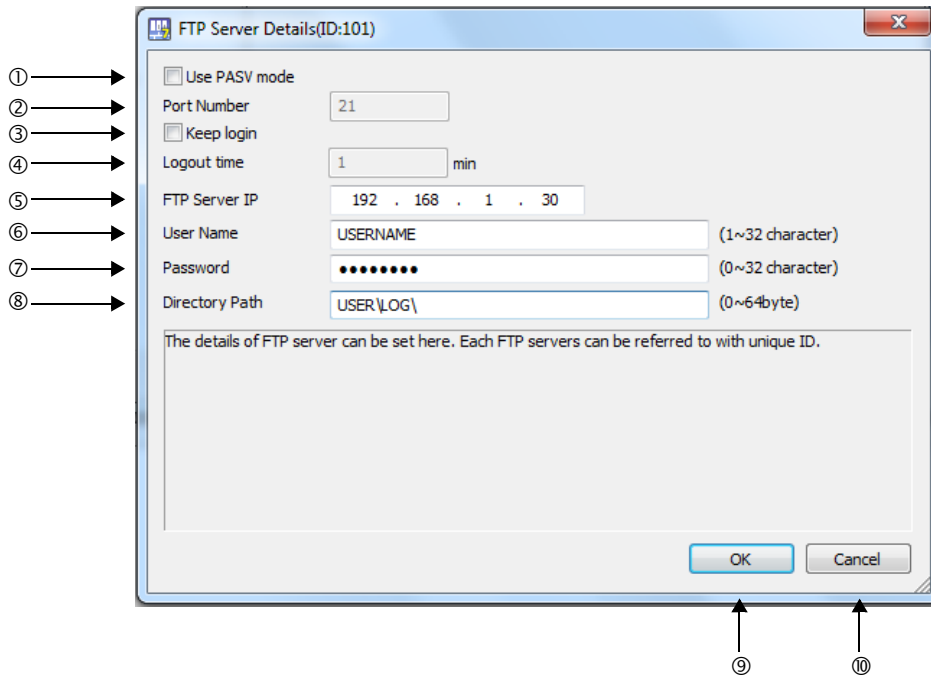

No.	Item	Description	Remarks
①	Use PASV mode	Specify whether to use PASV mode.	If PASV mode is not specified, ACTIV mode is used.
②	Port Number	1 to 65535 This setting is valid in PASV mode.	Port 21 is always used for ACTIV mode.
③	Keep login	Specify whether to stay logged in.	If you do not specify staying logged in, the FTP client will be logged out each time a file is uploaded.
④	Logout time	1 to 60 This setting is valid only when you specify staying logged in. The FTP client will be logged out if this time elapses before the next operation is performed after the last log file is transferred.	The FTP client will also be logged out for FTP transfer errors or if the CPU Module stops regardless of the logout time setting.
⑤	FTP Server IP	Enter the IP address of the FTP server. The setting range is determined by the IP address rules for the 2181FD.	The 2181FD settings are used for the gateway IP address and subnet mask.
⑥	User Name	Enter the login name for the FTP server.	1 to 32 characters There are no restrictions to the characters that can be used.
⑦	Password	Enter the login password for the FTP server.	0 to 32 characters There are no restrictions to the characters that can be used.
⑧	Directory Path	Set the directory path to which to write data in the FTP server.	0 to 64 characters There are no restrictions to the characters that can be used. Use slashes to separate directories. The file name that is specified for logging is used as the name of the file that is written.
⑨	OK Button	Click the OK Button to apply the changes and end.	-
⑩	Cancel Button	Click the Cancel Button without applying the changes.	-

■ Precautions

- Logging Overruns
FTP transfers are performed as part of the logging function. Logging data is not possible during FTP transfers. Adjust the amount of data to log and the timing so that logging overruns do not occur.
- Watchdog Timeout Errors for Large Data Transfers
If you transfer a large quantity of data with an FTP transfer when there is little idle time in the high-speed or low-speed scan, a scan exceeded error may occur. If you frequently transfer large amounts of data, provide sufficient idle time in scan processing.
- Online Parameter Changes for FTP Client Settings
If you change the FTP client settings when an FTP transfer is not in progress, the changes are made online. If an FTP transfer is in progress, the changes will not be applied and the operation will continue with the original settings. If the **Keep login** Option is selected, the system assumes that an FTP transfer is in progress as long as the FTP client is logged in. Therefore, the changes will not be applied and the operation will continue with the original settings. Changes that were not applied will be applied after restarting after data is saved to flash memory.

3.2.8 Security

Security can be used to perform the following tasks.

- Set project passwords.
- Set program passwords.
- Set online passwords.

Refer to the following manual for operating details.

 MP3000 Series Machine Controller System Setup Manual (Manual No.: SIEP C880725 00)

3.2.9 Calendar

The calendar is used to manage dates and times. If the calendar has been set, the date and time (unit: s or 0.01 μ s) will be automatically recorded when an alarm occurs.

The calendar is powered by the Battery. This allows it to maintain the correct time even if the power to the CPU Module is turned OFF. The calendar has an error of 1 minute a month.

The date and time information can be set, changed, and accessed through the system registers. Refer to the following section for details.

 ■ *Calendar* on page 4-17

Regular Calendar and μ s Calendar

There are two types of calendars: the regular calendar and the μ s calendar. The following table gives the major differences between the two.

Item	Regular Calendar	μ s Calendar
Supported Versions	All versions	Version 1.44 or higher
Unit	s	0.01 μ s
System Register	SW00015 onward	SW15815 onward
	Refer to the following section for details.  ■ <i>Calendar</i> on page 4-17	
Update Timing	Updated in system background processing.	The value of the μ s calendar and that of the regular calendar will be the same when specifying or changing regular calendar settings, and when the power is turned on. Thereafter, the μ s calendar is updated when high-speed scan is executed.
	Due to this difference, a deviation of approximately a few seconds per day may occur between the regular calendar and μ s calendar.	

Information If you want to change the set date and time, change the regular calendar settings.

System Operation Time

The system operation time is the total time that the system has been operating. Use of a battery backup for the calendar enables the count to be increased even when the power of the Machine Controller is turned OFF. The count of the total time is increased when high-speed scan is executed.

The system operation time can be checked with version 1.44 or higher.

The maximum value for system operation time is 9999999999999999 (approx. 277,777 hours).

The system operation time is reset to zero and counting restarted if any of the following occurs.

- The system operation time when the power is turned on exceeds the maximum value.
- Initialization operation is performed by using the MPE720.
- The power is turned ON with the **Battery Connection** set to **Not connect** under **Environment Setting - Setup** in the MPE720.
- The power is turned on when the Battery is not connected.

3.2.10 Maintenance Monitoring

You can use maintenance monitoring to monitor maintenance data in the Machine Controller and in Σ -7-series SERVOPACKs connected to the Machine Controller through MECHATROLINK communications.

Information If you use maintenance monitoring at the same time as the SigmaWin+, both the SigmaWin+ and maintenance monitoring may become slower.

Specifications

The models that support maintenance monitoring and the maintenance data that you can monitor are given in the following tables.

◆ Applicable Models

Applicable Models		Remarks
Machine Controllers	CPU-301	–
	CPU-302	–
SERVOPACKs	Σ -7S	Only SERVOPACKs that support MECHATROLINK-III communications.  <i>Setting Procedure</i> on page 3-103
	Σ -7W	
MPE720	MPE720 Version 7	–

◆ Maintenance Data

Data Category	Detailed Contents
Installation environment data	Temperature environment load status of Machine Controller, SERVOPACKs, and Servomotors
Power consumption data	Power consumptions of SERVOPACKs and Servomotors
Life estimation data	<ul style="list-style-type: none"> • Total operating times of SERVOPACKs • Remaining lives of consumable parts (internal fans, capacitors, inrush-current prevention circuits, and dynamic brake circuits)
Sensing data	Data related to control, communication quality, and operating status calculated inside SERVOPACKs

Setting Procedure

Use the following procedure to set the maintenance monitor.

1. Click the **Maintenance Monitor Settings** Icon from the Start Tab Page.

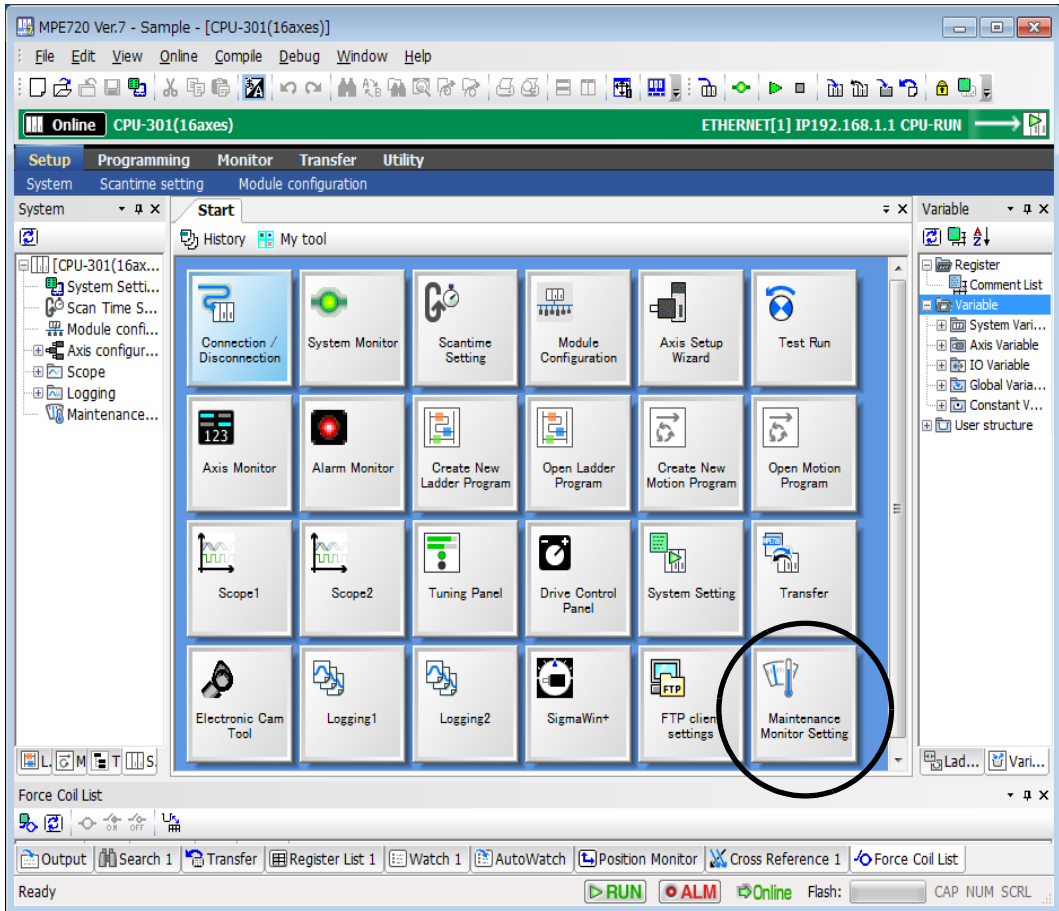

The Maintenance Monitor Settings Dialog Box will be displayed.

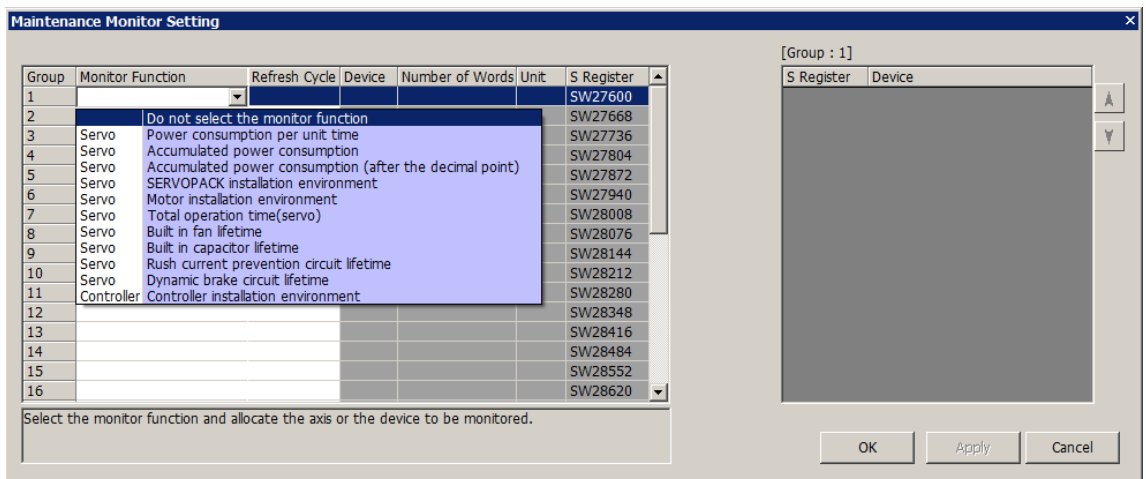

2. Set the maintenance monitor data.

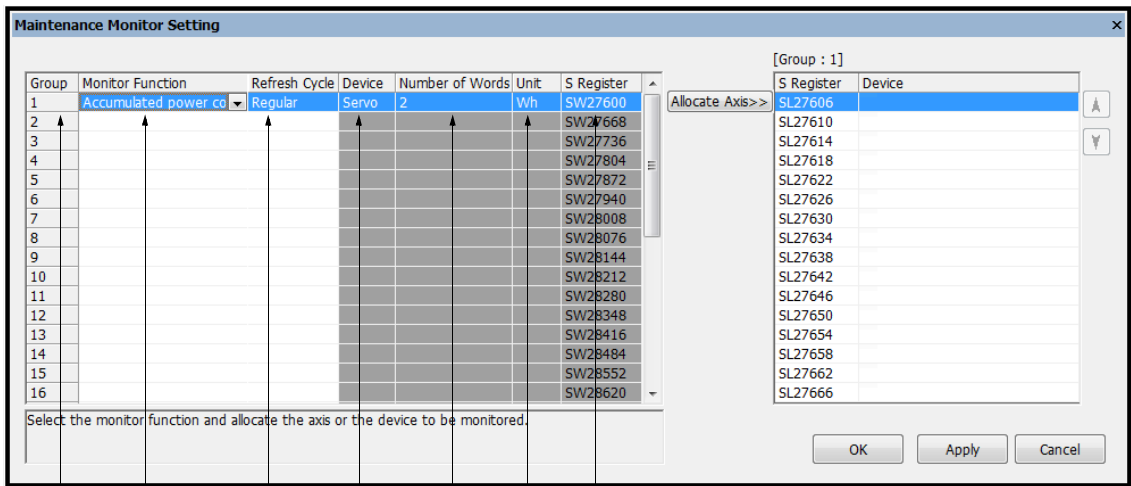

- ① Select a group number.
- ② Select the item to monitor.
- ③ Refresh Cycle
- ④ Monitored device
- ⑤ Monitor data size
- ⑥ Monitor data unit
- ⑦ First address of system registers to which to output the monitor data

- ① Select a group number.
Maximum number of groups: 32
- ② Select the item to monitor.

Selection	Contents	Monitored Device	Number of Words	Unit	Supported Versions
Power consumption per unit time	The power consumption per unit time is displayed.	SERVO-PACK	2	1 Wh	<ul style="list-style-type: none"> • Machine Controller: Version 1.12 or higher • SERVO-PACK: Version 000C or higher • MPE720: Version 7.28 or higher
Accumulated power consumption	The accumulated power consumption since operation was started is displayed.	SERVO-PACK	2	1 Wh	
Accumulated power consumption (after the decimal point)	The three digits below the decimal point of the accumulated power consumption since operation was started are displayed.	SERVO-PACK	2	0.001 Wh	
SERVOPACK installation environment	The temperature environment load status in the SERVOPACK is displayed.	SERVO-PACK	1	1%	
Motor installation environment	The temperature environment load status in the Servomotor is displayed.	SERVO-PACK	1	1%	
Total operation time (servo)	The total operating time of the SERVOPACK is displayed.	SERVO-PACK	2	100 ms	
Built in fan lifetime	The total operating time of the cooling fan is displayed as a percentage. When usage is first started, 100% is displayed. The percentage become smaller as the operating time increases. When 0% is displayed, it is time to consider replacement.	SERVO-PACK	1	0.01%	
Built in capacitor lifetime	The maintenance time of the electrolytic capacitors in the main circuit and control circuit is displayed as a percentage. When usage is first started, 100% is displayed. The percentage become smaller as the operating time increases. When 0% is displayed, it is time to consider replacement.	SERVO-PACK	1	0.01%	

Continued on next page.

Continued from previous page.

Selection	Contents	Monitored Device	Number of Words	Unit	Supported Versions
Rush current prevention circuit lifetime	The maintenance period of the inrush prevention relay is displayed as a percentage. When usage is first started, 100% is displayed. The percentage become smaller as the operating time increases. When 0% is displayed, it is time to consider replacement.	SERVO-PACK	1	0.01%	<ul style="list-style-type: none"> Machine Controller: Version 1.12 or higher SERVO-PACK: Version 000C or higher
Dynamic brake circuit lifetime	The maintenance period of the IGBT is displayed as a percentage. When usage is first started, 100% is displayed. The percentage become smaller as the operating time increases. When 0% is displayed, it is time to consider replacement.	SERVO-PACK	1	0.01%	<ul style="list-style-type: none"> MPE720: Version 7.28 or higher
Controller installation environment	The temperature environment load status in the Machine Controller is displayed.	Machine Controller	1	1%	<ul style="list-style-type: none"> Machine Controller: Version 1.14 or higher MPE720: Version 7.30 or higher
Maximum value of amplitude of estimated vibration	The maximum value of vibration amplitude of the estimated vibration calculated inside the SERVOPACK is displayed. This is compared with the value during regular operation in order to determine changes in the device due to deterioration over time and similar causes. If this monitor value increases, vibration may occur in the device.	SERVO-PACK	1	1 min ⁻¹	
Maximum value of estimated external disturbance torque (force)	The maximum value of the estimated external disturbance torque (force) calculated inside the SERVOPACK is displayed. This is compared with the value during regular operation in order to determine changes in the device due to deterioration over time and similar causes. If this monitor value increases, the external disturbance torque (force) applied to the Servomotors may increase.	SERVO-PACK	1	1%	<ul style="list-style-type: none"> Machine Controller: Version 1.12 or higher SERVO-PACK: Version 002C or higher
Minimum value of estimated external disturbance torque (force)	The minimum value of the estimated external disturbance torque (force) calculated inside the SERVOPACK is displayed. This is compared with the value during regular operation in order to determine changes in the device due to deterioration over time and similar causes. If this monitor value decreases, the external disturbance torque (force) applied to the Servomotors may increase.	SERVO-PACK	1	1%	<ul style="list-style-type: none"> MPE720: Version 7.46 or higher
Number of serial encoder communications errors	The number of serial encoder communications errors is displayed. If this monitor value increases, the communication quality may decrease.	SERVO-PACK	2	1 time	
Number of MECHATROLINK communications errors	The number of MECHATROLINK communications errors is displayed. If this monitor value increases, the communication quality may decrease.	SERVO-PACK	2	1 time	

Continued on next page.

3.2 Function Modules

3.2.10 Maintenance Monitoring

Continued from previous page.

Selection	Contents	Monitored Device	Number of Words	Unit	Supported Versions
Temperature margin until Servomotor overheats	The temperature margin until Servomotor overheating is displayed. The SERVOPACK detects A.860 (Encoder Overheat) if the temperature margin drops below 0 [°C]. Monitoring of this monitor allows you to prevent the system from stopping due to A.860. The following models of motors can be monitored: SGM7M, SGM7J, SGM7A, SGM7P, SGM7G, SGM7F, SGMCV	Servomotors	1	1°C	<ul style="list-style-type: none"> Machine Controller: Version 1.12 or higher SERVOPACK: Version 002C or higher MPE720: Version 7.46 or higher
Maximum value of accumulated load ratio	The maximum value of accumulated load ratio for the SERVOPACK is displayed. This is compared with the value during regular operation in order to determine changes in the device due to deterioration over time and similar causes. If this monitor value increases, the load applied to the Servomotors may increase.	SERVOPACK	1	1%	

Information You can select the same monitor item for more than one group.

③ Select the data update period.

Selection	Meaning
Frequent	The data is updated approximately once every second.
Regular	The data is updated approximately once every 10 seconds.
Infrequent	The data is updated approximately once every 100 seconds.

Information The data update periods are guidelines. The update periods may be increased depending on the number of monitored axes.

3. Click the **Allocate Axis** Button.

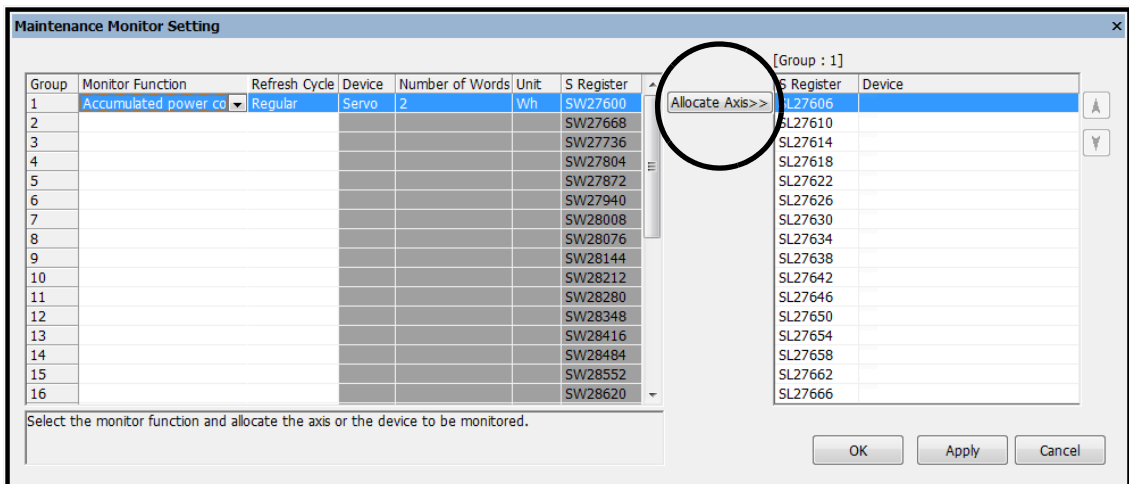

The Axis Selection Dialog Box will be displayed.

4. Select the axis to assign.

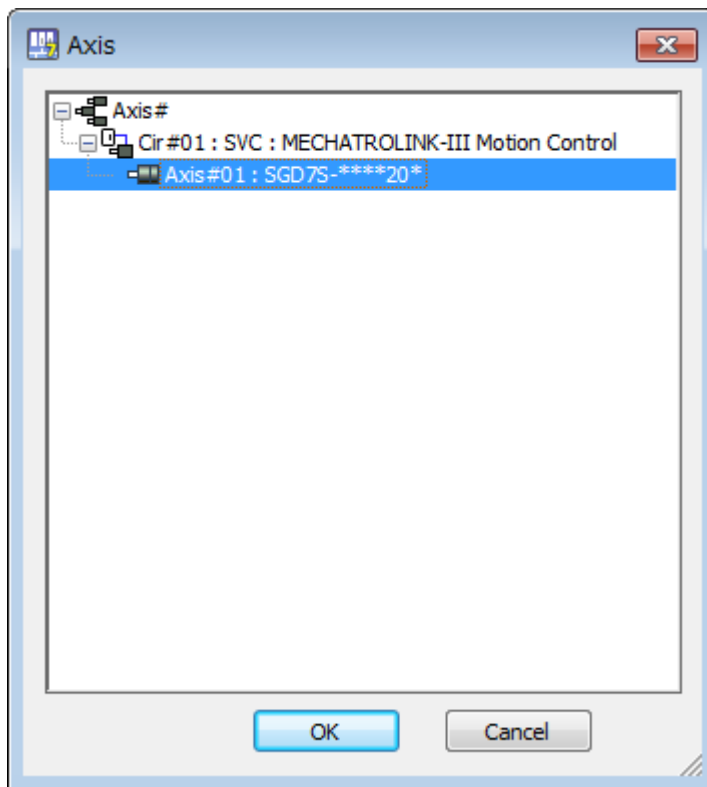

Maximum number of assigned axes: 16/group

5. Click the **OK** Button.
Monitoring will be started.

Confirmation Method

◆ System Registers

The monitored data is stored in system registers.

The ranges of the system registers that you can use for maintenance monitoring are given in the following table.

Information □□□□ is the first address of the system register that is displayed on the Maintenance Monitor Setting Dialog Box.

System Register	Item		Remarks
SL□□□□ + 0	Reserved for system (monitor parameter type).		–
SW□□□□ + 2	Monitor size		0001 hex: Word 0002 hex: Long word
SW□□□□ + 3	Reserved for system.		–
SW□□□□ + 4	Axis 1	Circuit number	If an error occurs, the error code is stored here.  ■ <i>Error Codes</i> on page 3-109
SW□□□□ + 5		Axis number	If an error occurs, the error code is stored here.  ■ <i>Error Codes</i> on page 3-109
SL□□□□ + 6		Monitor value	–
SW□□□□ + 8	Axis 2	Circuit number	Same as above.
SW□□□□ + 9		Axis number	
SW□□□□ + 10		Monitor value	
SW□□□□ + 12	Axis 3	Circuit number	Same as above.
SW□□□□ + 13		Axis number	
SL□□□□ + 14		Monitor value	
SW□□□□ + 16	Axis 4	Circuit number	Same as above.
SW□□□□ + 17		Axis number	
SL□□□□ + 18		Monitor value	
SW□□□□ + 20	Axis 5	Circuit number	Same as above.
SW□□□□ + 21		Axis number	
SL□□□□ + 22		Monitor value	
SW□□□□ + 24	Axis 6	Circuit number	Same as above.
SW□□□□ + 25		Axis number	
SL□□□□ + 26		Monitor value	
SW□□□□ + 28	Axis 7	Circuit number	Same as above.
SW□□□□ + 29		Axis number	
SL□□□□ + 30		Monitor value	
SW□□□□ + 32	Axis 8	Circuit number	Same as above.
SW□□□□ + 33		Axis number	
SL□□□□ + 34		Monitor value	
SW□□□□ + 36	Axis 9	Circuit number	Same as above.
SW□□□□ + 37		Axis number	
SL□□□□ + 38		Monitor value	
SW□□□□ + 40	Axis 10	Circuit number	Same as above.
SW□□□□ + 41		Axis number	
SL□□□□ + 42		Monitor value	
SW□□□□ + 44	Axis 11	Circuit number	Same as above.
SW□□□□ + 45		Axis number	
SL□□□□ + 46		Monitor value	

Continued on next page.

Continued from previous page.

System Register	Item		Remarks
SW□□□□ + 48	Axis 12	Circuit number	Same as above.
SW□□□□ + 49		Axis number	
SL□□□□ + 50		Monitor value	
SW□□□□ + 52	Axis 13	Circuit number	Same as above.
SW□□□□ + 53		Axis number	
SL□□□□ + 54		Monitor value	
SW□□□□ + 56	Axis 14	Circuit number	Same as above.
SW□□□□ + 57		Axis number	
SL□□□□ + 58		Monitor value	
SW□□□□ + 60	Axis 15	Circuit number	Same as above.
SW□□□□ + 61		Axis number	
SL□□□□ + 62		Monitor value	
SW□□□□ + 64	Axis 16	Circuit number	Same as above.
SW□□□□ + 65		Axis number	
SL□□□□ + 66		Monitor value	



■ Error Codes

If reading the monitor data cannot be completed normally, one of the following error codes is displayed in the system registers that normally contain the axis circuit number and axis number.

System Registers		Error
Circuit Number	Axis Number	
80 hex	18 hex	Relay error: An error occurred in message communications with the SERVOPACK.
80 hex	22 hex	Timeout error: A response was not received from the SERVOPACK within 5 seconds.

◆ Monitoring Methods

You can use the following methods to monitor the data stored in the system registers.

- Ladder Programming
Refer to the following manual for operating details.
 MPE720 Version 7 User's Manual (Manual No.: SIEP C880761 03)
- Tracing
Refer to the following manual for operating details.
 MPE720 Version 7 User's Manual (Manual No.: SIEP C880761 03)
- Data Logging
Refer to the following section for operating details.
 3.2.5 Data Logging on page 3-66

Information You can also use a touch panel to monitor the stored data.

Specifications

4

This section provides the installation and usage conditions of the MP3300. It also provides detailed specifications of the MP3300.

4.1 Installation and Usage Conditions 4-2

- 4.1.1 Installation and Operating Conditions 4-2
- 4.1.2 Control Panel Cooling Method 4-3

4.2 CPU Module Specifications 4-4

- 4.2.1 Hardware Specifications 4-4
- 4.2.2 Performance Specifications 4-5
- 4.2.3 Communications Specifications 4-8
- 4.2.4 Motion Control Function Module Specifications 4-9
- 4.2.5 M-EXECUTOR Specifications 4-10
- 4.2.6 USB Memory Specifications 4-11
- 4.2.7 System Register Specifications 4-11

4.3 Base Unit Specifications 4-60

4.1 Installation and Usage Conditions

4.1.1 Installation and Operating Conditions

The installation and usage conditions for the Machine Controller are given in the following table.

	Item	Specification
Environmental Conditions	Ambient Operating Temperature	0 to 60°C (Forced cooling is required if 55°C is exceeded.)
	Ambient Storage Temperature	-25 to 85°C
	Ambient Operating Humidity	10% to 95% RH (with no condensation)
	Ambient Storage Humidity	10% to 95% RH (with no condensation)
	Pollution Level	Conforms to JIS B 3502 Pollution Degree 2.
	Corrosive Gas	There must be no combustible or corrosive gas.
	Operating Altitude	2,000 m max.
Mechanical Operating Conditions	Vibration Resistance	Conforms to JIS B 3502. <ul style="list-style-type: none"> • Continuous vibration: 5 to 9 Hz with single-amplitude of 1.75 mm 9 to 150 Hz with fixed acceleration of 4.9 m/s² • Intermittent vibration: 5 to 9 Hz with single-amplitude of 3.5 mm 9 to 150 Hz with fixed acceleration of 9.8 m/s² 10 sweeps each in X, Y, and Z directions for both intermittent and continuous vibration
	Shock Resistance	Size of shock: Peak acceleration of 147 m/s ² (15 G) Duration: 11 ms 3 times each in X, Y, and Z directions
Electrical Operating Conditions	Noise Resistance	Conforms to EN 61000-6-2, EN 61000-6-4, and EN 55011 (Group 1 Class A). Power supply noise (FT noise): ±2 kV min. for one minute Radiation noise (FT noise): ±1 kV min. for one minute Ground noise (impulse noise): ±1 kV min. for 10 minutes Electrostatic noise (contact discharge method): ±6 kV or more, 10 times
Installation Conditions	Ground	Ground to 100 Ω max.
	Cooling Method	Natural cooling or forced-air cooling Refer to the following section for details.  4.1.2 Control Panel Cooling Method on page 4-3

4.1.2 Control Panel Cooling Method

The components that are used in the Machine Controller require the ambient operating temperature to be between 0 and 60°C. Use one of the methods described below to ensure adequate cooling in the control panel.



If the ambient temperature exceeds 55°C, use forced-air cooling.

Control Panels with Natural Cooling

- Do not mount the Machine Controller at the top of the control panel, where the hot air that is generated inside the panel collects.
- Leave sufficient space above and below the Machine Controller, and maintain adequate distances from other devices, cable ducts, and other objects to ensure suitable air circulation.
- Do not mount the Machine Controller in any direction other than the specified direction.
- Do not mount the Machine Controller on top of any device that generates a significant amount of heat.
- Do not subject the Machine Controller to direct sunlight.

Control Panels with Forced-air Cooling

For either of the following methods, install a fan near the center of and at the top or bottom of the Machine Controller.

- Forced draft method (A fan or a similar device is used to circulate the air in the interior and the exterior of the panel.)
- Forced circulation method (A fan or a similar device is mounted to the airtight panel to circulate the air inside.)

Information

1. Use the following guideline when selecting the fan:
 - 80 × 80 mm min., Maximum air flow: 0.9 m³/min, Maximum static pressure: 26.5 Pa or higher
2. Adjust the fan installation location and the direction of air flow as shown in the following diagram.

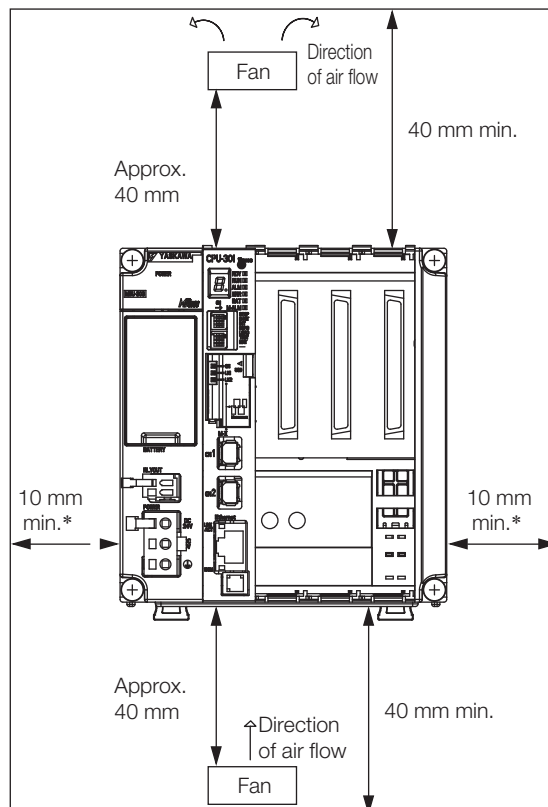



* For a control panel with natural cooling with a Base Unit other than the MBU-304: 30 mm min.

4.2 CPU Module Specifications

This section provides the specifications that are related to the performance, hardware, functionality, and registers of the CPU Module.

4.2.1 Hardware Specifications

The hardware specifications of the CPU Module are given in the following table.

Item	Specification			
Model	JAPMC-CP3301-1-E	JAPMC-CP3301-2-E	JAPMC-CP3302-1-E	JAPMC-CP3302-2-E
Abbreviation	CPU-301 (16 axes)	CPU-301 (32 axes)	CPU-302 (16 axes)	CPU-302 (32 axes)
Flash Memory	Capacity: 24 MB (15 MB of user memory)	Capacity: 40 MB (31 MB of user memory)	Capacity: 24 MB (15 MB of user memory)	Capacity: 40 MB (31 MB of user memory)
SDRAM	Capacity: 256 MB			
SRAM	Capacity: 4 MB (battery backup)	Capacity: 8 MB (battery backup)	Capacity: 4 MB (battery backup)	Capacity: 8 MB (battery backup)
Calendar	Seconds, minutes, hour, day, week, month, year, day of week, and timing (battery backup)			
Battery	You can mount a memory backup Battery.			
Ethernet	One port, 10Base-T or 100Base-TX			
MECHATROLINK	<ul style="list-style-type: none"> • MECHATROLINK-III: 1 circuit with 2 ports • Master • Slave 			
USB	<ul style="list-style-type: none"> • USB 2.0 Type A host, 1 port • Compatible devices: USB storage 			
Indicators and Displays	<ul style="list-style-type: none"> • Seven-segment display • Status indicators • USB status indicator • MECHATROLINK-III status indicators • Ethernet status indicators Refer to the following section for details.  2.1.2 Display and Indicators on page 2-4			
Switches	<ul style="list-style-type: none"> • DIP switch: Mode switch • STOP/SAVE switch Refer to the following section for details.  2.1.3 Switches on page 2-7			
Connectors	<ul style="list-style-type: none"> • MECHATROLINK-III connectors • Ethernet connectors • USB connector Refer to the following section for details.  2.1.4 Connectors on page 2-9			

4.2.2 Performance Specifications

This section provides the performance specifications of the CPU Module.

Item		Specification		Remarks
		CPU-301 (16 axes)	CPU-301 (32 axes)	
		CPU-302 (16 axes)	CPU-302 (32 axes)	
System Configuration	Maximum Number of Racks	4		Number of Main Racks: 1 max. Number of Expansion Racks added by using EXIOIF Modules: 3 max.
	Maximum Number of Base Units Controllable by One CPU Unit	4		You must use EXIOIF Modules to add Expansion Racks.
	Maximum Number of Optional Modules Controllable by the Main CPU Unit	35		Main Rack: 1 Base Unit × 8 slots Expansion Racks added by using EXIOIF Modules: 3 Base Units × 9 slots each
Number of Controlled Axes	SVC	16 axes, 1 circuit	–	Circuit number selected from 1 to 16.
	SVC32	–	32 axes, 1 circuit	Circuit number selected from 1 to 16.
	SVR	16 axes, 1 circuit	–	Circuit number selected from 1 to 16.
	SVR32	–	32 axes, 1 circuit	Circuit number selected from 1 to 16.
	Maximum Number of Controlled Axes	256 axis		Optional Modules (SVB-01 or SVC-01 Modules) must be mounted. Note: The number of controlled axes of the SVC, SVC32, SVR, and SVR32 given above are included.
Scan Time Settings	H Scan	CPU-301	0.25 to 32.0 ms (in 0.125-ms increments)	Refer to the following section for details.  3.1.4 Scans on page 3-29
		CPU-302	0.125 to 32.0 ms (in 0.125-ms increments)	
	L Scan	2.0 to 300 ms (in 0.5-ms increments)		–
	H Scan Default	4 ms		–
	L Scan Default	200 ms		–
Peripheral Devices	Calendar	Provided.		–
	Communications Interface	Ethernet		–
	USB	Provided.		–
Memory Capacity	DRAM	256 MB with ECC		–
	SRAM (battery backup)	4 MB	8 MB	For battery backup of table data, the CPU-301 for 16 axes uses up to 1 MB and the CPU-301 for 32 axes uses up to 3 MB.
	Program Capacity	15 MB	31 MB	Total capacity including definition data, ladder programs, table data, etc.

Continued on next page.

4.2 CPU Module Specifications

4.2.2 Performance Specifications

Continued from previous page.

	Item	Specification		Remarks
		CPU-301 (16 axes)	CPU-301 (32 axes)	
		CPU-302 (16 axes)	CPU-302 (32 axes)	
Ladder Programs	Number of Startup Drawings (DWG.A)	64		Number of steps per drawing: 4,000
	Number of Interrupt Drawings (DWG.I)	64		
	Number of High-speed Scan Drawings (DWG.H)	1000		
	Number of Low-speed Scan Drawings (DWG.L)	2000		
	Number of User Function Drawings	2000		
Motion Programs	Number of Programs	512		Total of all programs listed below: • Motion main programs • Motion subprograms • Sequence main programs • Sequence subprograms
	Number of Groups	16		–
	Number of Tasks	32		–
	Number of Nesting Levels for IF Instructions	8		–
	Number of Nesting Levels for MSEE Instructions	8		–
	Number of Parallel Forks Per Task	8		Select from the following four options: • Main: 4 forks, Sub: 2 forks • Main: 8 forks • Main: 2 forks, Sub: 4 forks • Sub: 8 forks
	Number of Simultaneously Controlled Axes Per Task	32 axes		–
Registers	S Registers	64 Kwords		–
	M Registers	1 Mword		Battery backup
	G Registers	2 Mwords		No battery backup
	I/O Registers	64 Kwords		–
	Motion Registers	32 Kwords		–
	C Registers	16 Kwords		–
	# Registers	16 Kwords		–
Data Types	D Registers	16 Kwords		–
	Bit (B)	Supported.		0, 1
	Integer (W)	Supported.		-32,768 to 32,767
	Double-length Integer (L)	Supported.		-2,147,483,648 to 2,147,483,647
	Quadruple-length Integer (Q)	Supported.		-9,223,372,036,854,775,808 to 9,223,372,036,854,775,807
	Single-precision Real Number (F)	Supported.		± (1.175E-38 to 3.402E+38), 0
	Double-precision Real Number (D)	Supported.		± (2.225E-308 to 1.798E+308), 0
	Addresses (A)	Supported.		0 to 16,777,214

Continued on next page.

Continued from previous page.

Item		Specification		Remarks	
		CPU-301 (16 axes)	CPU-301 (32 axes)		
		CPU-302 (16 axes)	CPU-302 (32 axes)		
Index Registers	Subscript i	Supported.		Special registers for offsetting addresses. Subscripts i and j function identically.	
	Subscript j	Supported.			
	Array Registers	Supported.			Used to handle registers as arrays
Data Tracing	Number of Groups	4		–	
	Trace Memory	256 Kword total in 4 groups	1 Mword total in 4 groups	–	
	Traceable Data Points	16 points per group		–	
	Trigger Types	>, <, =, <>, >=, <= and differential detection of the above conditions		–	
Data Logging	Number of Groups	4		–	
	Log Storage Location	Built-in RAM disk, USB memory device, or FTP server		The following storage capacity limits apply when built-in RAM is utilized. • Version 1.43 or lower: 8 MB • Version 1.44 or higher: 64 MB	
	Log File Formats	CSV file format or binary file format		–	
	Data Logging Points	256 points per group		–	
	Number of Log Files	Built-in RAM Disk	1 to 4000		–
		USB Memory	1 to 32,767 or unlimited		The ultimate upper limit is 10,000 files even if unlimited is selected.
FTP Server		1 to 4000		–	
	Trigger Types	>, <, =, <>, >=, <=		–	
Compatibility with MP2000-series Optional Modules	Refer to the following section for details.  1.3.2 <i>Optional Modules</i> on page 1-8				

4.2.3 Communications Specifications

This section provides the communications specifications of the CPU Module.

Item		Specification	Remarks	
Abbreviation		218IFD	–	
Common Items	Communications Interface	10Base-T or 100Base-TX	–	
	Number of Communications Ports (Connectors)	1	–	
	Communications Protocols	TCP, UDP, IP, ARP, or ICMP	–	
Ethernet Communications	Maximum Number of Communications Connections		20 + 2 (I/O message communications)	
	Maximum Number of Communications Channels		10 + 2 (I/O message communications)	
	Automatic Reception		Supported.	Not supported for no-protocol communications.
	Maximum Number of Automatic Reception Connections		10	–
	Maximum Size of Message Communications	MEMOBUS	Write: 100 words Read: 125 words	–
		Extended MEMOBUS	Write: 2,043 words Read: 2,044 words	–
		MELSEC (A-compatible 1E)	Write: 256 words Read: 256 words	–
		MELSEC (QnA-compatible 3E)	Write: 960 words Read: 960 words	–
		MODBUS/TCP	Write: 100 words Read: 125 words	–
		OMRON	Write: 996 words Read: 999 words	–
		TOYOPUC	Write: 1,022 words	–
		No-protocol	Write: 2,046 words	–
	Maximum Size of I/O Message Communications	MEMOBUS	Write: 100 words Read: 125 words	–
		Extended MEMOBUS	Write: 1,024 words Read: 1,024 words	–
		MELSEC (A-compatible 1E)	Write: 256 words Read: 256 words	–
		MELSEC (QnA-compatible 3E)	Write: 256 words Read: 256 words	–
		MODBUS/TCP	Write: 100 words Read: 125 words	–
OMRON		Write: 996 words Read: 999 words	–	
Receive Buffer Mode Selection for No-protocol Communications		Supported.	–	
Engineering Tool	Communications Platform	Ethernet	–	
	Controller Searches	Supported.	–	

4.2.4 Motion Control Function Module Specifications

The specifications of the Motion Control Function Module that is built into the CPU Module are given in the following table.

Item		Specification		Remarks	
		CPU-301 (16 axes)	CPU-301 (32 axes)		
		CPU-302 (16 axes)	CPU-302 (32 axes)		
MECHATROLINK communications settings	Number of Communications Lines	1		–	
	Number of Communications Ports (Connectors)	2		–	
	Communi- cations cycle (cycle for refreshing data)	CPU-301	250 μ s to 32.0 ms		–
		CPU-302	125 μ s to 32.0 ms		
	Master	Communications Method	M-III		–
		Baud Rate	100 Mbps		–
		Communications Cycle	125 μ s/ 250 μ s/ 0.5 ms/ 1 ms	125 μ s, 250 μ s, 0.5 ms, 1 ms, 1.5 ms, 2 ms, or 3 ms	–
		Number of Connected Stations	21 stations (up to 16 servo sta- tions)	42 stations (up to 32 servo sta- tions)	–
		Message Relaying	Supported.		–
		C2 Messages	Supported.		Automatically set by the system.
		Retries	Supported.		–
		Asynchronous Setting of High-speed Scan Cycle and Communications Cycle	Not supported.		An alarm will occur if setting is attempted.
	Slave	Communications Method	M-III		–
		Communications Cycle	125 μ s min.		–
		Slave CPU synchronization	Supported.		–

4.2.5 M-EXECUTOR Specifications

This section provides the M-EXECUTOR specifications of the CPU Module.

Registerable Programs

Program Type		Number of Registered Programs
Motion Programs		32*
Sequence Programs	Startup	1
	Interrupt	Not possible.
	H Scan	32*
	L Scan	32*

* The combined total of motion programs and sequence programs must not exceed 32.



Program Control Methods

You can use the following control methods for the programs that are registered in the M-EXECUTOR:

Item	Motion Programs	Sequence Programs										
Execution method	Sequential execution	Startup: Event execution H scan: Scan execution L scan: Scan execution										
System work	There is a one-to-one correspondence between the definition number and system work number.											
	<table border="1"> <thead> <tr> <th>Definition No.</th> <th>System Work Number</th> </tr> </thead> <tbody> <tr> <td>No.1</td> <td>1</td> </tr> <tr> <td>No.2</td> <td>2</td> </tr> <tr> <td>⋮</td> <td>⋮</td> </tr> <tr> <td>No.32</td> <td>32</td> </tr> </tbody> </table>		Definition No.	System Work Number	No.1	1	No.2	2	⋮	⋮	No.32	32
Definition No.	System Work Number											
No.1	1											
No.2	2											
⋮	⋮											
No.32	32											
Program designation method	Direct designation or indirect designation	Direct designation										
Program execution method	Register the program in the definitions and start execution by turning ON the start signal.	Execution is started when the program is registered in the definitions.										
Interpolation override setting	Supported.	Not supported.										
I/O link definitions	Supported.	Not supported.										
Motion program status reporting in S registers	Supported.											
Number of parallel forks	Up to 8 • Main: 4 forks, Sub: 2 forks • Main: 8 forks • Main: 2 forks, Sub: 4 forks • Sub: 8 forks	No forks										
Error diagram execution when an operation error occurs	Supported.											

4.2.6 USB Memory Specifications

The specifications of the USB memory in the CPU Module are given in the following table.

Item	Specification	Remarks
Supported Media	USB memory device	Refer to the following section for details.  <i>Recommended USB Memory Device</i> on page 4-11
Applicable FAT	FAT16/32	–
Maximum number of nested directories	10	–
File information	Last update time-stamps are supported.	Uses the calendar in the Machine Controller. Refer to the following section for details.  <i>3.2.9 Calendar</i> on page 3-101
Maximum length for file name and directory names	256 characters	–
Current Directory Function	16	–
Maximum number of simultaneously open files	16	–
Formatting	Not supported.	Use a formatted USB memory device.

Recommended USB Memory Device

The following USB memory device is recommended. It can be purchased from Yaskawa.

Model	Specification	Manufacturer
SFU24096E3BP2TO-I-DT-121-STD	4 GB USB memory	Swissbit Japan Inc.

4.2.7 System Register Specifications

This section provides the specifications of the system registers.



Important Do not use the registers reserved for the system.

Overall Configuration

The following table shows the overall configuration of the system registers.

You can read error information and the operating status of the system by specifying the system register address.

Register Address	Description	Details
SW00000 to SW00029	System Service Registers	◆ <i>System Service Registers</i> on page 4-14
SW00030 to SW00049	System Status	◆ <i>CPU System Status</i> on page 4-18
SW00050 to SW00079	System Error Status	◆ <i>System Error Status</i> on page 4-19
SW00080 to SW00089	User Operation Error Status	◆ <i>User Operation Error Status in Ladder Programs</i> on page 4-20
SW00090 to SW00103	System Service Execution Status	◆ <i>System Service Execution Status</i> on page 4-23
SW00104 to SW00109	Reserved for system.	–

Continued on next page.

4.2 CPU Module Specifications

4.2.7 System Register Specifications

Continued from previous page.

Register Address	Description	Details
SW00110 to SW00189	Detailed User Operation Error Status	◆ <i>Detailed User Operation Error Status</i> on page 4-23
SW00190 to SW00199	Reserved for system.	–
SW00200 to SW00503	System I/O Error Status	◆ <i>System I/O Error Status</i> on page 4-24
SW00504 and SW00505	Reserved for system.	–
SW00506 and SW00507	Security Status	◆ <i>Security Status</i> on page 4-25
SW00508 to SW00649	Reserved for system.	–
SW00650 to SW00667	USB-related System Status	◆ <i>USB-related System Status</i> on page 4-25
SW00668 to SW00693	Reserved for system.	–
SW00694 to SW00697	Message Relaying Status	◆ <i>Message Relaying Status</i> on page 4-26
SW00698 to SW00789	Interrupt Status	◆ <i>Interrupt Status</i> on page 4-26
SW00790 to SW00799	Reserved for system.	–
SW00800 to SW00815	CPU Module Information	◆ <i>CPU Module Information</i> on page 4-27
SW00816 to SW01095	Optional Module Information	◆ <i>Optional Module Information</i> on page 4-29
SW01096 to SW01410	Reserved for system.	–
SW01411 to SW01442	MPU-01 Module Status	◆ <i>MPU-01 Module Status</i> on page 4-33
SW01443 to SW01474	Reserved for system.	–
SW01475 to SW01482	Sub CPU Status	This system register is not used because this product does not have Sub CPU synchronization.
SW01483 to SW02687	Reserved for system.	–
SW02688 to SW03199	PROFINET Controller (266IF-01) IOPS Status	◆ <i>PROFINET Controller (266IF-01) IOPS Status Information</i> on page 4-35
SW03200 to SW05119	Motion Program Information	◆ <i>Motion Program Execution Information</i> on page 4-36
SW05120 to SW05247	Used by the system (system memory read).	–
SW05248 to SW08191	Reserved for system.	–
SW08192 to SW09215	Extended Motion Program Information	◆ <i>Motion Program Execution Information</i> on page 4-36
SW09216 to SW09559	Reserved for system.	–
SW09560 to SW13699	Extended System I/O Error Status	◆ <i>System I/O Error Status</i> on page 4-24
SW13700 to SW13747	Extended CPU Module Information	◆ <i>CPU Module Information</i> on page 4-27
SW13748 to SW15795	Extended Optional Module Information	◆ <i>Optional Module Information</i> on page 4-29

Continued on next page.

Continued from previous page.

Register Address	Description	Details
SW15796 to SW15799	Reserved for system.	–
SW15800	Extended System Status	This system register is not used because this product does not have Racks 5 to 7.
SW15801 to SW15814	Reserved for system.	–
SW15815 to SW15827	Extended System Service Registers	◆ <i>System Service Registers</i> on page 4-14
SW15828 to SW15997	Reserved for system.	–
SW15998 to SW16011	Extended System Service Execution Status	◆ <i>Expansion System Service Execution Status</i> on page 4-48
SW16012 to SW16199	Reserved for system.	–
SW16200 to SW17999	Alarm History Information	◆ <i>Alarm History Information</i> on page 4-48
SW18000 to SW19999	Reserved for system.	–
SW20000 to SW22063	Product Information	◆ <i>Product Information</i> on page 4-50
SW22064 to SW22999	Reserved for system.	–
SW23000 to SW23159	Unit and Rack Information	This system register is not used because this product does not have Racks 5 to 7.
SW23160 to SW23999	Reserved for system.	–
SW24000 to SW24321	Data Logging Execution Status	◆ <i>Data Logging Execution Status</i> on page 4-51
SW24322 to SW24399	Reserved for system.	–
SW24400 to SW24719	FTP Client Status and Controls	◆ <i>FTP Client Status and Control Information</i> on page 4-52
SW24720 to SW24999	Reserved for system.	–
SW25000 to SW25671	Automatic Reception Status for Ethernet Communications	◆ <i>Automatic Reception Status for Ethernet Communications</i> on page 4-54
SW25672 to SW27599	Reserved for system.	–
SW27600 to SW29775	Maintenance Monitor Information	◆ <i>Maintenance Monitor Information</i> on page 4-56
SW29776 to SW65534	Reserved for system.	–

Details

This section gives details on the system registers.

◆ System Service Registers



The execution status and specifications of the programs are stored in these registers. The System Service Registers are reset to zero when the system is started.

■ Shared by All Drawings

Register Address	Name	Remarks	
SW00000	SB000000	Reserved for system.	–
	SB000001	High-speed Scan	ON for only the first scan after high-speed scan is started.
	SB000002	Reserved for system.	–
	SB000003	Low-speed Scan	ON for only the first scan after low-speed scan is started.
	SB000004	Always ON	Always ON (set to 1).
	SB000005	High-speed Scan 2	Only ON for one scan when the high-speed scan starts after the CPU Unit is changed to RUN Mode.
	SB000006	Low-speed Scan 2	Only ON for one scan when the low-speed scan starts after the CPU Unit is changed to RUN Mode.
	SB000007	High-speed Scan in Progress	1: High-speed scan in progress
	SB000008	MP2000 Option Service Executing	ON (set to 1) during service scan for the MP2000-series Optional Modules.
	SB000009 to SB00000F	Reserved for system.	–



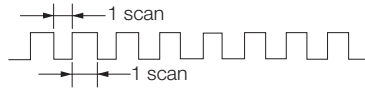
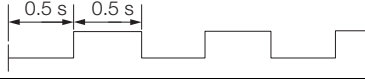
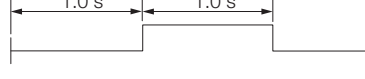
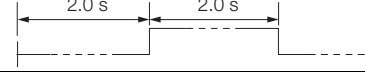
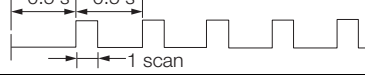
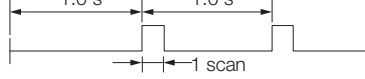
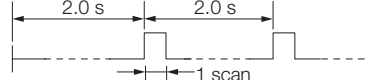
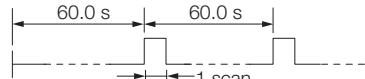
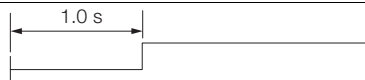

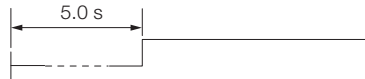
■ DWG.H Only

Operation starts when the high-speed scan starts.

Register Address	Name	Remarks
SW00001	SB000010	1-scan Flicker Relay 
	SB000011	0.5-s Flicker Relay 
	SB000012	1.0-s Flicker Relay 
	SB000013	2.0-s Flicker Relay 
	SB000014	0.5-s Sampling Relay 
	SB000015	1.0-s Sampling Relay 
	SB000016	2.0-s Sampling Relay 
	SB000017	60.0-s Sampling Relay 
	SB000018	1.0 s After Start of Scan Process 
SW00001	SB000019	2.0 s After Start of Scan Process 
	SB00001A	5.0 s After Start of Scan Process 
	SB00001B to SB00001F	Reserved for system.
SW00002	Reserved for system.	-

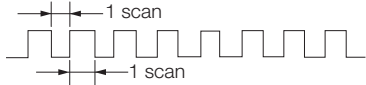
■ DWG.L Only

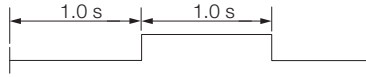
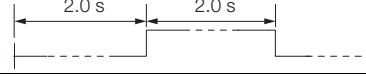
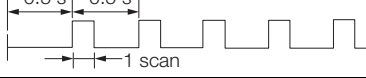
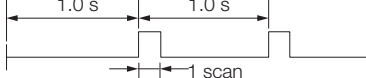
Operation starts when the low-speed scan starts.

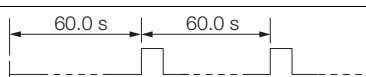
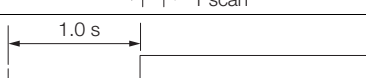
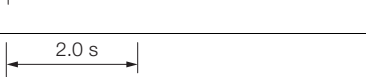
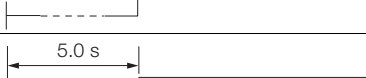
Register Address	Name	Remarks
SW00003	SB000030	1-scan Flicker Relay 
	SB000031	0.5-s Flicker Relay 
	SB000032	1.0-s Flicker Relay 
	SB000033	2.0-s Flicker Relay 
	SB000034	0.5-s Sampling Relay 
	SB000035	1.0-s Sampling Relay 
	SB000036	2.0-s Sampling Relay 
	SB000037	60.0-s Sampling Relay 
	SB000038	1.0 s After Start of Scan Process 
	SB000039	2.0 s After Start of Scan Process 
	SB00003A	5.0 s After Start of Scan Process 
	SB00003B to SB00003F	Reserved for system.

■ System Execution Status

Register Address	Name	Remarks
SW00004	High-speed Scan Set Value	High-speed scan set value (0.1 ms)
SW00005	Current High-speed Scan Time	Current high-speed scan time (0.1 ms)
SW00006	Maximum High-speed Scan Time	Maximum high-speed scan time (0.1 ms)
SW00007	High-speed Scan Set Value 2	High-speed scan set value (μs)
SW00008	Current High-speed Scan Time 2	Current high-speed scan time (μs)
SW00009	Maximum High-speed Scan Time 2	Maximum high-speed scan time (μs)
SW00010	Low-speed Scan Set Value	Low-speed scan set value (0.1 ms)
SW00011	Current Low-speed Scan Time	Current low-speed scan time (0.1 ms)
SW00012	Maximum Low-speed Scan Time	Maximum low-speed scan time (0.1 ms)
SW00013	Reserved for system.	-
SW00014	Current Scan Time	Scan time of currently executing scan (0.1 ms)

■ Calendar

Refer to the following section for details.

 3.2.9 Calendar on page 3-101

Register Address	Name	Remarks	Example
SW00015	Regular Calendar: Year	Gives the last two digits of the year in BCD format.	2011: 0011
SW00016	Regular Calendar: Month and Day	Gives the month and day in BCD format.	December 31: 1231
SW00017	Regular Calendar: Hours and Minutes	Gives the hours and minutes in BCD format.	23 hours 59 minutes: 2359
SW00018	Regular Calendar: Seconds	Gives the seconds in BCD format.	59 seconds: 0059
SW00019	Regular Calendar: Week	Gives the day of the week as a number between 0 and 6. 0: Sunday, 1: Monday, 2: Tuesday, 3: Wednesday, 4: Thursday, 5: Friday, and 6: Saturday	–
SW15815	μs Calendar: Year	Gives the last two digits of the year in BCD format.	2011: 0011
SW15816	μs Calendar: Month and Day	Gives the month and day in BCD format.	December 31: 1231
SW15817	μs Calendar: Hours and Minutes	Gives the hours and minutes in BCD format.	23 hours 59 minutes: 2359
SQ15820	μs Calendar: Seconds	Gives the seconds in DEC format. Unit: 0.01 μs	59.12345 seconds: 5912345000

■ System Program Software Version

Register Address	Name	Remarks
SW00020	System Program Software Version	Ver.□□.□□ (Gives the □□□□ in BCD format.)
SW00021 to SW00025	Reserved for system.	–

■ Remaining Program Memory Capacity

Register Address	Name	Remarks
SL00026	Remaining Program Memory Capacity	Bytes
SL00028	Total Memory Capacity	Bytes

■ System Operation Time

Refer to the following section for details.

 3.2.9 Calendar on page 3-101

Register Address	Name	Remarks
SQ15824	System Operation Time	Unit: 0.01 μs

◆ CPU System Status

The operating status or error status of the system is stored in the following system registers. You can check these system registers to determine whether the cause of the error is hardware or software related. The System Status Registers are reset to zero when the system is started.

Name	Register Address		Description	
Reserved for system.	SW00030 to SW00039		-	
CPU Status	SW00040	SB000400	READY	0: Error, 1: Ready
		SB000401	Run	0: Stopped, 1: Running
		SB000402	ALARM	0: Normal, 1: Alarm
		SB000403	ERROR	0: Normal, 1: Error
		SB000404	Reserved for system.	-
		SB000405	M-ALM	0: Normal, 1: Axis alarm
		SB000406	FLASH	0: INIT Start, 1: Flash Operation
		SB000407	WEN	0: Writing disabled, 1: Writing enabled
		SB000408 and SB000409	Reserved for system.	-
		SB00040A	Flash Save Request from MPE720	0: Not saving data to flash memory, 1: Saving data to flash memory
		SB00040B to SB00040D	Reserved for system.	-
		SB00040E	Operation Stop Request from MPE720	0: RUN selected, 1: STOP selected
		SB00040F	Run Switch Status at Power ON	0: STOP, 1: RUN
		CPU Error Status	SW00041	SB000410
SB000411 and SB000412	Reserved for system.			-
SB000413	Exception Error			0: Normal, 1: Exception error
SB000414 to SB000417	Reserved for system.			-
SB000418	User Operation Error			0: Normal, 1: User operation error
SB000419	I/O Error			0: Normal, 1: I/O error
SB00041A	MPU-01 Error			0: Normal, 1: MPU-01 error
SB00041B	Reserved for system.			-
SB00041C	MECHATROLINK-III Station Address Duplication			0: Normal 1: MECHATROLINK-III slave device station address duplication
SB00041D	MECHATROLINK-III Restrictions Error			0: Normal, 1: Restrictions error in MECHATROLINK-III communications cycle
SB00041E	Reserved for system.			-
SB00041F	Temperature Warning	0: Normal, 1: Temperature warning		
H Scan Exceeded Counter	SW00044		H Scan Exceeded Count	
L Scan Exceeded Counter	SW00046		L Scan Exceeded Count	
Reserved for system.	SW00047	SB000470 to SB00047F	Reserved for system.	-

Continued on next page.

Continued from previous page.

Name	Register Address	Description		
Hardware Configuration Status	SW00048	SB000480	Reserved for system.	
		SB000481	LOAD	
		SB000482	CNFG	
		SB000483	INIT	
		SB000484	E-INIT	
		SB000485	STOP	
		SB000486	Reserved for system.	–
		SB000487	Battery Alarm	–
		SB000488 and SB000489	Reserved for system.	–
		SB00048A	MNT	Mode switch 2 setting status 0: OFF, 1: ON
		SB00048B	TEST	–
		SB00048C to SB00048F	Reserved for system.	–
Reserved for system.	SW00049	Reserved for system.	–	

◆ System Error Status

The system error status shows the error status of the system. The data is stored in the following system registers.

Name	Register Address	Description	
32-bit Error Code	SW00050	0001 hex	Watchdog timeout error
		0051 hex	Module synchronization error
	SW00051	For system error analysis	
32-bit Error Address	SW00052 and SW00053	For system error analysis	
Program Error Task	SW00054	0000 hex	system
		0001 hex	DWG.A
		0002 hex	DWG.I
		0003 hex	DWG.H
		0005 hex	DWG.L
Program Type	SW00055	0000 hex	system
		0001 hex	DWG.A
		0002 hex	DWG.I
		0003 hex	DWG.H
		0005 hex	DWG.L
		0008 hex	Function
Program Error Drawing Number	SW00056	000F hex	Motion program or sequence program
		FFFF hex	Ladder program parent drawing
		8000 hex	Ladder program function
		□□00 hex	Ladder program child drawing (H□□: Child drawing No.)
		xxyy hex	Ladder program grandchild drawing (Hxx: Child drawing No., Hyy: Grandchild drawing No.)
F□□□ hex	Motion program or sequence program (H□□□: Program No.)		

Continued on next page.

Continued from previous page.

Name	Register Address	Description	
Drawing Type of Calling Program	SW00057	Type of the calling drawing in which the error occurred	
		0001 hex DWG.A	
		0002 hex DWG.I	
		0003 hex DWG.H	
		0005 hex DWG.L	
		0008 hex Function	
Drawing Type of Calling Program	SW00058	Number of the calling drawing in which the error occurred	
		FFFF hex Parent drawing	
		8000 hex Function	
		□□00 hex Child drawing (H□□: Child drawing No.)	
		xyxy hex Grandchild drawing (Hxx: Child drawing No., Hyy: Grandchild drawing No.)	
Drawing Step No. in Calling Program	SW00059	Step Number in the Calling Drawing in Which the Error Occurred This is set to 0 if the error occurs in the parent drawing.	
Error Data	SW00060 and SW00061	Reserved for system.	
	SW00062 to SW00065	Name of task that caused the error	
	SW00066 and SW00067	Reserved for system.	
	SW00068	Year When Error Occurred	
	SW00069	Month When Error Occurred	
	SW00070	Day of Week When Error Occurred	
	SW00071	Day When Error Occurred	
	SW00072	Hour When Error Occurred	
	SW00073	Minutes When Error Occurred	
	SW00074	Seconds When Error Occurred	
	SW00075	Milliseconds When Error Occurred	
	SW00076	xyzz hex	Slot Where the Module Synchronization Error Was Detected (x: Rack number from 1 to 7, y: unit number from 1 to 4, zz: slot number from 01 to 09)
	SW00077 to SW00079	Reserved for system.	

◆ User Operation Error Status in Ladder Programs

The user operation error status shows operation errors in the ladder programs. The data is stored in the following system registers.

Refer to the following sections for details on the user operation error status.

■ Detailed User Operation Error Status on page 4-23

Drawing Type	Error Description	Register Address	Description
DWG.A	Error Count	SW00080	<ul style="list-style-type: none"> • Error Count Gives the number of errors that have occurred. • Error Code Gives the details of the error. 0□□□ hex: Operation error ■ User Operation Error Code -1: Operation Errors on page 4-21 x□□□ hex (x = 1, 2, 3): Index error ■ User Operation Error Code -2: Index Errors on page 4-22
	Error Code	SW00081	
DWG.I	Error Count	SW00082	
	Error Code	SW00083	
DWG.H	Error Count	SW00084	
	Error Code	SW00085	
Reserved for system.		SW00086 and SW00087	
DWG.L	Error Count	SW00088	
	Error Code	SW00089	

■ User Operation Error Code –1: Operation Errors

	Error Code	Error Description	Operation When an Error Occurs*			
Integer Operations	0001 hex	Integer operation underflow	[-32768]			
	0002 hex	Integer operation overflow	[32767]			
	0003 hex	Integer operation division error	[The A register stays the same.]			
	0009 hex	Double-length integer operation underflow	[-2147483648]			
	000A hex	Double-length integer operation overflow	[2147483647]			
	000B hex	Double-length integer operation division error	[The A register stays the same.]			
	000C hex	Quadruple-length integer operation underflow	[-9223372036854775808]			
	000D hex	Quadruple-length integer operation overflow	[9223372036854775807]			
	000E hex	Quadruple-length integer operation division error	[The A register stays the same.]			
	0101 hex to 010E hex	Integer operation error in Operation Error Drawing	[The A register stays the same.]			
Real Number Operations	0010 hex	Non-numerical integer storage error	Data is not stored. [00000]			
	0011 hex	Integer storage underflow	Data is not stored. [-32768]			
	0012 hex	Integer storage overflow	Data is not stored. [+32767]			
	0021 hex	Real number storage underflow	Data is not stored. [-1.0E+38]			
	0022 hex	Real number storage overflow	Data is not stored. [1.0E+38]			
	0023 hex	Real number operation division by zero error	Data is not stored. [The F register stays the same.]			
	0030 hex	Invalid real number operation (non-numeric)	Data is not stored.			
	0031 hex	Real number operation exponent underflow	0.0			
	0032 hex	Real number operation exponent overflow	Maximum Value			
	0033 hex	Real number operation division error (0/0)	Operation is not executed.			
	0034 hex	Real number storage exponent underflow	Stores 0.0.			
		0040 hex to 0059 hex	Real number operation error in standard system function	Operation is aborted and output is set to 0.0.		
			0040 hex: SQRT	0047 hex: EXP	004E hex: PD	0055 hex: SLAU
			0041 hex: SIN	0048 hex: LN	004F hex: PID	0056 hex: REM
	0042 hex: COS		0049 hex: LOG	0050 hex: LAG	0057 hex: RCHK	
	0043 hex: TAN		004A hex: DZA	0051 hex: LLAG	0058 hex: BSRCH	
	0044 hex: ASIN		004B hex: DZB	0052 hex: FGN	0059 hex: SORT	
	0045 hex: ACOS		004C hex: LIM	0053 hex: IFGN	–	
	0046 hex: ATAN	004D hex: PI	0054 hex: LAU			

* The numeric values given in brackets [] are set by the system in the Changed A Register or Changed F Register before the operation error drawing is executed.

■ User Operation Error Code -2: Index Errors

	Error Code	Error Description	Operation When an Error Occurs			
Integer and Real Number Operations	1000 hex	Index error in drawing	Re-executed as if i and j were set to 0. (Both i and j registers stay the same.)			
	2000 hex	Index error in function	Re-executed as if i and j were set to 0. (Both i and j registers stay the same.)			
	3000 hex	Index error in motion program or sequence program	Re-executed as if i and j were set to 0. (Both i and j registers stay the same.)			
Real Number Operations	x040 hex to x059 hex (x=1,2,3)	Real number operation error in standard system function	Operation is aborted and output is set to 0.0.			
		x040 hex: SQRT	x047 hex: EXP	x04E hex: PD	x055 hex: SLAU	
		x041 hex: SIN	x048 hex: LN	x04F hex: PID	x056 hex: REM	
		x042 hex: COS	x049 hex: LOG	x050 hex: LAG	x057 hex: RCHK	
		x043 hex: TAN	x04A hex: DZA	x051 hex: LLAG	x058 hex: BSRCH	
		x044 hex: ASIN	x04B hex: DZB	x052 hex: FGN	x059 hex: SORT	
		x045 hex: ACOS	x04C hex: LIM	x053 hex: IFGN	-	
		x046 hex: ATAN	x04D hex: PI	x054 hex: LAU	-	
Integer Operations	x060 hex to x0C9 hex (x=1,2,3)	Integer operation error in standard system function	Operation is aborted and output is set to input. [The A register stays the same.]			
		x06D hex: PI	x091 hex: ROTR	x0A0 hex: BEXTEND	x0B1 hex: SPEND	
		x06E hex: PD	x092 hex: MOV B	x0A1 hex: BPRESS	x0C0 hex: TBLBR	
		x06F hex: PID	x093 hex: MOV W	x0A2 hex: SORT	x0C1 hex: TBLBW	
		x070 hex: LAG	x094 hex: SET W	x0A4 hex: SORT	x0C2 hex: TBL SRL	
		x071 hex: LLAG	x095 hex: XCHG	x0A6 hex: RCHK	x0C3 hex: TBL SRC	
		x072 hex: FGN	x096 hex: LIMIT	x0A7 hex: RCHK	x0C4 hex: TBL CL	
		x073 hex: IFGN	x097 hex: LIMIT	x0A8 hex: COPY W	x0C5 hex: TBL MW	
		x074 hex: LAU	x098 hex: DZA	x0A9 hex: ASCII	x0C6 hex: QTBL R	
		x075 hex: SLAU	x099 hex: DZA	x0AA hex: BINASC	x0C7 hex: QTBL RI	
		x076 hex: FGN	x09A hex: DZB	x0AB hex: ASCBIN	x0C8 hex: QTBL W	
		x077 hex: IFGN	x09B hex: DZB	x0AC hex: BSRCH	x0C9 hex: QTBL WI	
		x08E hex: INS	x09C hex: PWM	x0AD hex: BSRCH	-	
		x08F hex: OUTS	x09E hex: SHFTL	x0AE hex: TIMEADD		
		x090 hex: ROTL	x09F hex: SHFTR	x0AF hex: TIMSUB		

■ Detailed User Operation Error Status

Details when a user operation error occurs in a user program are stored in the following system registers.

Name	Register Address				Remarks
	DWG.A	DWG.I	DWG.H	DWG.L	
Error Count	SW00110	SW00126	SW00142	SW00174	<ul style="list-style-type: none"> Error Drawing No. FFFF hex: Parent drawing □□00 hex: Child drawing (H□□: Child drawing No.) xxyy hex: Grandchild drawing (Hxx: Child drawing No., Hyy: Grandchild drawing No.) 8000 hex: Function F□□□ hex: Motion program or sequence program (H□□□: Program No.) Calling Drawing No. Number of the calling drawing in which the operation error occurred Calling Drawing Step No. Step number in the calling drawing in which the operation error occurred This number is set to 0 if the error occurs in the parent drawing. Error Step No. Step number when the operation error occurred
Error Code	SW00111	SW00127	SW00143	SW00175	
Error A Registers	SW00112	SW00128	SW00144	SW00176	
	SW00113	SW00129	SW00145	SW00177	
Changed A Registers	SW00114	SW00130	SW00146	SW00178	
	SW00115	SW00131	SW00147	SW00179	
Error F Registers	SW00116	SW00132	SW00148	SW00180	
	SW00117	SW00133	SW00149	SW00181	
Changed F Registers	SW00118	SW00134	SW00150	SW00182	
	SW00119	SW00135	SW00151	SW00183	
Address Where Error Occurred	SW00120	SW00136	SW00152	SW00184	
	SW00121	SW00137	SW00153	SW00185	
Error Drawing No.	SW00122	SW00138	SW00154	SW00186	
Calling Drawing No.	SW00123	SW00139	SW00155	SW00187	
Calling Drawing Step No.	SW00124	SW00140	SW00156	SW00188	
Error Step No.	SW00125	SW00141	SW00157	SW00189	

◆ System Service Execution Status

The system service execution status shows the execution status of the system. The data is stored in the following system registers.

Name	Register Address		Remarks
Reserved for system.	SW00090 to SW00097		–
Data Trace Definition Existence	SW00098	SB000980	Group 1
		SB000981	Group 2
		SB000982	Group 3
		SB000983	Group 4
		SB000984 to SB000987	Reserved for system.
Data Trace Enabled or Disabled Status	SW00098	SB000988	Group 1
		SB000989	Group 2
		SB00098A	Group 3
		SB00098B	Group 4
		SB00098C to SB00098F	Reserved for system.

Continued on next page.

Continued from previous page.

Name	Register Address		Remarks		
Data Trace Execution Status	SW00099	SB000990	Group 1	0: Tracing in progress, 1: Tracing stopped	
		SB000991	Group 2		
		SB000992	Group 3		
		SB000993	Group 4		
Data Trace Trigger Condition Status		SB000994 to SB000997	Reserved for system.		
		SB000998	Group 1	0: Trace is not waiting for trigger condition, 1: Trace is waiting for trigger condition	
		SB000999	Group 2		
		SB00099A	Group 3		
		SB00099B	Group 4		
SB00099C to SB00099F	Reserved for system.				
Group 1 Record No.	SW00100		Latest record number in group 1.		
Group 2 Record No.	SW00101		Latest record number in group 2.		
Group 3 Record No.	SW00102		Latest record number in group 3.		
Group 4 Record No.	SW00103		Latest record number in group 4.		

◆ System I/O Error Status

The system I/O error status shows the I/O error status of the system. The data is stored in the following system registers.

Name	Register Address		Remarks
	MP2000 Compatible	MP3000 Expansion	
I/O Error Count	SW00200	SW09560	Number of I/O error occurrences
Input Error Count	SW00201	SW09561	Number of input error occurrences
Input Error Address	SW00202	SL09562	Latest input error address (register address in IW□□□□)
Reserved for system.	–	SW09564	–
Output Error Count	SW00203	SW09565	Number of output error occurrences
Output Error Address	SW00204	SL09566	Latest output error address (register address in OW□□□□)
Reserved for system.	SW00205 to SW00207	SW09568 to SW09571	–
I/O Error Status	SW00208 to SW00223	SW09572 to SW09603	CPU Module Error Status Refer to the following manual for details. 📖 MP3000 Series Machine Controller System Troubleshooting Manual (Manual No.: SIEP C880725 01)
	SW00224 to SW00503*1	SW09604 to SW13699*2	Optional Modules/Vision Unit Error Status System registers where error status is stored vary with the rack configuration. For details on the system registers and error status, refer to the following manual. 📖 MP3000 Series Machine Controller System Troubleshooting Manual (Manual No.: SIEP C880725 01)

*1. Area of system register: 8 words from the first register

*2. Area of system register: 32 words from the first register

◆ Security Status

The security status shows the execution status of online security.

The contents of the security status in detail are stored in the following system registers.

Name	Register Address	Description	
Security Status	SW00506	0: Security disabled, 1: Security enabled	
Security Read Protection Information	SW00507	SB005070 to SB005073	Restriction rights for file reading
		SB005074 to SB005076	Reserved for system.
		SB005077	File reading restriction
		SB005078 to SB00507F	Reserved for system.

□□□□ hex

Restriction rights level (0 to 7)
Reserved for system.
File reading restriction
0: Not restricted
1: Restricted
Reserved for system.

◆ USB-related System Status

The USB information and abnormal condition data are stored in the following system registers.

Name	Register Address	Remarks	
Available USB Memory	SL00650	Unit: Kilobytes	
Total USB Memory	SL00652		
USB Status	SW00654	SB006540	0: No USB memory device, 1: USB memory device inserted
		SB006541	0: Not supplying power, 1: Supplying power
		SB006542	0: Cannot recognize USB memory device, 1: Recognized USB memory device
		SB006543	0: Not accessing USB memory device, 1: Accessing USB memory device
		SB006544	0: -, 1: Checking FAT file system
		SB006545 to SB00654F	Reserved for system.
FAT Type	SW00655	0002 hex	FAT16
		0003 hex	FAT32
Reserved for system.	SW00656 and SW00657	-	
Batch Load and Batch Save	SW00658	SB006580	1: Batch load in progress
		SB006581	1: USB memory read error
		SB006582	1: Load file model mismatch error
		SB006583	1: Load file write error
		SB006584	1: Save to flash memory error
		SB006585	1: Folder for batch loading does not exist
		SB006586	1: Loading error due to program write protection
		SB006587	Reserved for system.
		SB006588	1: Batch save in progress
		SB006589	1: USB memory write error
		SB00658A	1: Save file read error
SB00658B	1: Security error		
SB00658C to SB00658F	Reserved for system.		
Reserved for system.	SW00659 to SW00667	-	

◆ Message Relaying Status

The status of the command or response of the message function is stored in the following system registers.

Name	Register Address	Description
Message Relaying Information	SW00694	Normally processed command message counter
	SW00695	Command message error counter
	SW00696	Normally processed response message counter
	SW00697	Response message error counter

◆ Interrupt Status

The interrupt status shows the status of information on interrupts from each I/O Module.

Not all Optional Module models can store interrupt status information. Refer to the following manual for details.

📖 MP3000 Series Machine Controller System Troubleshooting Manual (Manual No.: SIEP C880725 01)

■ Configuration of the System Registers

The interrupt status is stored in the following system registers.

Name	Register Address	Remarks
Interrupt Detection Count	SW00698	–
Module Where an Interrupt Occurred	SW00699	Number of Modules with a single interrupt
Interrupt Modules	SW00700 to SW00702	Interrupt Module 1
	SW00703 to SW00705	Interrupt Module 2
	:	:
	SW00787 to SW00789	Interrupt Module 30

Refer to the following section for details.
 **Details on page 4-26**

■ Details

The following table gives details on the Interrupt Modules.

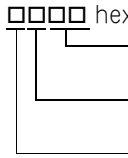
Register Address	Remarks
SW007□□ + 0	Rack No., Unit No., Slot No.  □□□□ hex 01 to 09: Gives the slot number where the Module in which the interrupt occurred is mounted. 1 to 4: Gives the unit number of the Module in which the interrupt occurred is mounted. 1 to 7: Gives the Rack number where the Module in which the interrupt occurred is mounted.
SW007□□ + 1	Interrupt Type 1: Reserved for system. 2: DI interrupt 3: Counter interrupt
SW007□□ + 2	Register Value for Hardware Interrupt Cause The contents depend on the hardware that is being used. Refer to the following manual for details. 📖 MP3000 Series Machine Controller System Troubleshooting Manual (Manual No.: SIEP C880725 01)

◆ CPU Module Information

The information on the CPU Module is stored in the following system registers.

- SW00800 to SW01095: System registers compatible with those of the MP2000 Series
- SW13700 to SW15795: System registers expanded with those of the MP3000 Series

■ System Registers Compatible with Those of MP2000 Series

Register Address	Remarks
SW00800	CPU Module ID
SW00801	Hardware version (HEX)
SW00802	Software version (BCD)
SW00803	Number of subslots (HEX)
SW00804	Function Module 1 ID (HEX)
SW00805	Function Module 1 Status
SW00806	Function Module 2 ID (HEX)
SW00807	Function Module 2 Status
SW00808	Function Module 3 ID (HEX)
SW00809	Function Module 3 Status
SW00810	Function Module 4 ID (HEX)
SW00811	Function Module 4 Status
SW00812	Function Module 5 ID (HEX)
SW00813	Function Module 5 Status
SW00814	Function Module 6 ID (HEX)
SW00815	Function Module 6 Status

■ Expansion System Registers of MP3000 Series

Register Address	Remarks
SW13700	CPU Module ID (Low)
SW13701	CPU Module ID (High)
SW13702	Hardware version (HEX)
SW13703	Software version (BCD)
SW13704	Number of subslots (HEX)
SW13705 to SW13707	Reserved for system.
SW13708	Function Module 1 ID (Low)
SW13709	Function Module 1 ID (High)
SW13710	Function Module 1 Status
SW13711	Reserved for system.
SW13712	Function Module 2 ID (Low)
SW13713	Function Module 2 ID (High)
SW13714	Function Module 2 Status
SW13715	Reserved for system.
SW13716	Function Module 3 ID (Low)
SW13717	Function Module 3 ID (High)
SW13718	Function Module 3 Status
SW13719	Reserved for system.
SW13720	Function Module 4 ID (Low)
SW13721	Function Module 4 ID (High)
SW13722	Function Module 4 Status
SW13723	Reserved for system.
SW13724	Function Module 5 ID (Low)
SW13725	Function Module 5 ID (High)
SW13726	Function Module 5 Status
SW13727	Reserved for system.
SW13728	Function Module 6 ID (Low)
SW13729	Function Module 6 ID (High)
SW13730	Function Module 6 Status
SW13731	Reserved for system.
SW13732	Function Module 7 ID (Low)
SW13733	Function Module 7 ID (High)
SW13734	Function Module 7 Status
SW13735	Reserved for system.
SW13736	Function Module 8 ID (Low)
SW13737	Function Module 8 ID (High)
SW13738	Function Module 8 Status
SW13739	Reserved for system.
SW13740	Function Module 9 ID (Low)
SW13741	Function Module 9 ID (High)
SW13742	Function Module 9 Status
SW13743	Reserved for system.
SW13744	Function Module 10 ID (Low)
SW13745	Function Module 10 ID (High)
SW13746	Function Module 10 Status
SW13747	Reserved for system.

◆ Optional Module Information



Information on each Optional Module differs in system register depending on the rack, unit, and slot in which the Optional Module is installed.

■ Configuration of the System Registers

- Upper row: System registers compatible with those of the MP2000 series
Area of system register: 8 words from the first register
- Lower row: System registers expanded with those of the MP3000 series
Area of system register: 16 words from the first register

Rack Number	Unit Number	Slot 1	Slot 2	Slot 3	Slot 4	Slot 5	Slot 6	Slot 7	Slot 8	Slot 9
Rack 1	Unit 1	SW00816	SW00824	SW00832	SW00840	SW00848	SW00856	SW00864	SW00872	–
		SW13748	SW13764	SW13780	SW13796	SW13812	SW13828	SW13844	SW13860	–
	Unit 2	–	–	–	–	–	–	–	–	–
		SW13876	SW13892	SW13908	SW13924	SW13940	SW13956	SW13972	SW13988	–
	Unit 3	–	–	–	–	–	–	–	–	–
		SW14004	SW14020	SW14036	SW14052	SW14068	SW14084	SW14100	SW14116	–
	Unit 4	–	–	–	–	–	–	–	–	–
		SW14132	SW14148	SW14164	SW14180	SW14196	SW14212	SW14228	SW14244	–
Rack 2	–	SW00880	SW00888	SW00896	SW00904	SW00912	SW00920	SW00928	SW00936	SW00944
		–	–	–	–	–	–	–	–	–
Rack 3	–	SW00952	SW00960	SW00968	SW00976	SW00984	SW00992	SW01000	SW01008	SW01016
		–	–	–	–	–	–	–	–	–
Rack 4	–	SW01024	SW01032	SW01040	SW01048	SW01056	SW01064	SW01072	SW01080	SW01088
		–	–	–	–	–	–	–	–	–
Rack 5	Unit 1	–	–	–	–	–	–	–	–	–
		SW14260	SW14276	SW14292	SW14308	SW14324	SW14340	SW14356	SW14372	–
	Unit 2	–	–	–	–	–	–	–	–	–
		SW14388	SW14404	SW14420	SW14436	SW14452	SW14468	SW14484	SW14500	–
	Unit 3	–	–	–	–	–	–	–	–	–
		SW14516	SW14532	SW14548	SW14564	SW14580	SW14596	SW14612	SW14628	–
	Unit 4	–	–	–	–	–	–	–	–	–
		SW14644	SW14660	SW14676	SW14692	SW14708	SW14724	SW14740	SW14756	–
Rack 6	Unit 1	–	–	–	–	–	–	–	–	–
		SW14772	SW14788	SW14804	SW14820	SW14836	SW14852	SW14868	SW14884	–
	Unit 2	–	–	–	–	–	–	–	–	–
		SW14900	SW14916	SW14932	SW14948	SW14964	SW14980	SW14996	SW15012	–
	Unit 3	–	–	–	–	–	–	–	–	–
		SW15028	SW15044	SW15060	SW15076	SW15092	SW15108	SW15124	SW15140	–
	Unit 4	–	–	–	–	–	–	–	–	–
		SW15156	SW15172	SW15188	SW15204	SW15220	SW15236	SW15252	SW15268	–
Rack 7	Unit 1	–	–	–	–	–	–	–	–	–
		SW15284	SW15300	SW15316	SW15332	SW15348	SW15364	SW15380	SW15396	–
	Unit 2	–	–	–	–	–	–	–	–	–
		SW15412	SW15428	SW15444	SW15460	SW15476	SW15492	SW15508	SW15524	–
	Unit 3	–	–	–	–	–	–	–	–	–
		SW15540	SW15556	SW15572	SW15588	SW15604	SW15620	SW15636	SW15652	–
	Unit 4	–	–	–	–	–	–	–	–	–
		SW15668	SW15684	SW15700	SW15716	SW15732	SW15748	SW15764	SW15780	–

Information

- The details of information on the Optional Module depend on the model. Refer to the following section for details.
 ■ *Detailed Configuration of System Registers of Information on Optional Module* on page 4-30
- Refer to the following section for Rack configuration in detail.
 1.1.4 *Rack Numbers* on page 1-3
- The system registers indicated by the shaded area are not used because this product does not have Racks 5 to 7.

■ **Detailed Configuration of System Registers of Information on Optional Module**

- System Registers (SW00816 to SW01095) Compatible with those of MP2000 Series

Register Address	Remarks
SW00□□□ + 0	Optional Module ID
SW00□□□ + 1	Hardware version (HEX)
SW00□□□ + 2	Software version (BCD)
SW00□□□ + 3	Number of subslots (HEX)
SW00□□□ + 4	Function Module 1 ID (HEX)
SW00□□□ + 5	Function Module 1 Status
SW00□□□ + 6	Function Module 2 ID (HEX)
SW00□□□ + 7	Function Module 2 Status

Refer to the following sections for the status in detail.
 ■ *Optional Module Information Detail* on page 4-31

- Expansion System Registers (SW13748 to SW15795) of MP3000 Series

Register Address	Remarks
SW□□□□□ + 0	Optional Unit and Optional Module ID (Low)
SW□□□□□ + 1	Optional Unit and Optional Module ID (High)
SW□□□□□ + 2	Hardware version (HEX)
SW□□□□□ + 3	Software version (BCD)
SW□□□□□ + 4	Number of subslots (HEX)
SW□□□□□ + 5 to SW□□□□□ + 7	Reserved for system.
SW□□□□□ + 8	Function Module 1 ID (Low)
SW□□□□□ + 9	Function Module 1 ID (High)
SW□□□□□ + 10	Function Module 1 Status
SW□□□□□ + 11	Reserved for system.
SW□□□□□ + 12	Function Module 2 ID (Low)
SW□□□□□ + 13	Function Module 2 ID (High)
SW□□□□□ + 14	Function Module 2 Status
SW□□□□□ + 15	Reserved for system.

Refer to the following sections for the status in detail.
 ■ *Optional Module Information Detail* on page 4-31

■ Optional Module Information Detail

- Optional Module ID, Number of Subslots, Function Module ID Detail

Optional Module	Details		
	Optional Module ID	Number of Subslots	Function Module ID
SVA-01	9093 hex	0001 hex	9013 hex
SVB-01	9195 hex	0001 hex	9115 hex
SVC-01	9490 hex	0001 hex	9410 hex
PO-01	9390 hex	0001 hex	9310 hex
MPU-01	82E0 hex	0001 hex	8260 hex
215AIF-01	8580 hex	0002 hex	<ul style="list-style-type: none"> • 215IF (Function Module 1): 8510 hex • MPLINK (Function Module 2): 8122 hex
216AIF-01	84A0 hex	0001 hex	8420 hex
217IF-01	8280 hex	0001 hex	8520 hex
218IF-01	8180 hex	0002 hex	8620 hex
218IF-02	8181 hex	0002 hex	8622 hex
260IF-01	8380 hex	0002 hex	8B20 hex
261IF-01	8480 hex	0002 hex	8C21 hex
262IF-01	8DA0 hex	0001 hex	8D20 hex
263IF-01	8BA8 hex	0001 hex	8B28 hex
264IF-01	87A0 hex	0001 hex	8720 hex
265IF-01	8BA4 hex	0001 hex	8B24 hex
266IF-01	8CA2 hex	0001 hex	8C22 hex
266IF-02	8CA3 hex	0001 hex	8C23 hex
267IF-01	82A4 hex	0001 hex	8224 hex
269IF-01	82A8 hex	0001 hex	8228 hex
LIO-01	8080 hex	0002 hex	<ul style="list-style-type: none"> • LIO (Function Module 1): 8050 hex • CNTR (Function Module 2): 8230 hex
LIO-02	8081 hex	0002 hex	<ul style="list-style-type: none"> • LIO (Function Module 1): 8050 hex • CNTR (Function Module 2): 8230 hex
LIO-04	80D5 hex	0001 hex	8055 hex
LIO-05	80D6 hex	0001 hex	8055 hex
LIO-06	80D7 hex	0002 hex	<ul style="list-style-type: none"> • MIXIO (Function Module 1): 8056 hex • CNTR-A (Function Module 2): 8232 hex
DI-01 (Currently under development)	80D3 hex	0001 hex	8053 hex
DO-01	80D4 hex	0001 hex	8054 hex
AI-01	80D0 hex	0001 hex	8051 hex
AO-01	80D1 hex	0001 hex	8052 hex
CNTR-01	82B0 hex	0001 hex	8231 hex

- Function Module Status Detail

Value	Text Displayed in MPE720 Module Configuration Definition	Status
0	None	There is no Module Definition and the Module is not mounted.
1	Empty	There is a Module Definition, but the Module is not mounted.
2	Operating (Driving)	The Module is operating normally.
3	Standby (Reserved for system.)	The Module is on standby.
4	Failure	An error was detected in the Module.
5	x Module name	The mounted Module does not match the definition.
6	Waiting for initialization	The Module is mounted, but there is no Detailed Function Module Definition.
7	Driving Stop	Local I/O is stopped.
8	Duplicate Address	The same station address is set for more than one of the connected MECHATROLINK-III slave devices.
9 or higher	–	Reserved for system.

◆ MPU-01 Module Status

The status of the MPU-01 Multi-CPU Module is stored in the following system registers.

Name	Register Address	Description
MPU-01 Module Status	SW01411	Status of MPU-01 Module circuit number 1
	SW01412	Error status of MPU-01 Module circuit number 1
	SW01413	Status of MPU-01 Module circuit number 2
	SW01414	Error status of MPU-01 Module circuit number 2
	SW01415	Status of MPU-01 Module circuit number 3
	SW01416	Error status of MPU-01 Module circuit number 3
	SW01417	Status of MPU-01 Module circuit number 4
	SW01418	Error status of MPU-01 Module circuit number 4
	SW01419	Status of MPU-01 Module circuit number 5
	SW01420	Error status of MPU-01 Module circuit number 5
	SW01421	Status of MPU-01 Module circuit number 6
	SW01422	Error status of MPU-01 Module circuit number 6
	SW01423	Status of MPU-01 Module circuit number 7
	SW01424	Error status of MPU-01 Module circuit number 7
	SW01425	Status of MPU-01 Module circuit number 8
	SW01426	Error status of MPU-01 Module circuit number 8
	SW01427	Status of MPU-01 Module circuit number 9
	SW01428	Error status of MPU-01 Module circuit number 9
	SW01429	Status of MPU-01 Module circuit number 10
	SW01430	Error status of MPU-01 Module circuit number 10
	SW01431	Status of MPU-01 Module circuit number 11
	SW01432	Error status of MPU-01 Module circuit number 11
	SW01433	Status of MPU-01 Module circuit number 12
	SW01434	Error status of MPU-01 Module circuit number 12
	SW01435	Status of MPU-01 Module circuit number 13
	SW01436	Error status of MPU-01 Module circuit number 13
	SW01437	Status of MPU-01 Module circuit number 14
	SW01438	Error status of MPU-01 Module circuit number 14
	SW01439	Status of MPU-01 Module circuit number 15
	SW01440	Error status of MPU-01 Module circuit number 15
	SW01441	Status of MPU-01 Module circuit number 16
	SW01442	Error status of MPU-01 Module circuit number 16

■ MPU-01 Module Circuit □ Status Detail

Name	Register Address	Description		
MPU-01 Module Circuit □ Status	SB014□□0	READY	0: WDG, Self-diagnostic error, Sync error 1: Normal	
	SB014□□1	RUN	0: Stopped (STOP) 1: Operating (RUN)	
	SB014□□2	ALARM	0: Normal 1: Alarm (Reset when the cause of the alarm is eliminated)	
	SB014□□3	ERROR	0: Normal 1: Error (Resetting)	
	SW01411 SW01413 SW01415	SB014□□4	Reserved for system.	
	SW01417 SW01419	SB014□□6	FLASH	0: INIT Start 1: Flash Operation
	SW01421 SW01423	SB014□□7	WEN	0: Writing disabled 1: Writing enabled
	SW01425 SW01427 SW01429	SB014□□8	BAT	0: Normal 1: The battery alarm occurred
	SW01431 SW01433	SB014□□9	Reserved for system.	
	SW01435	SB014□□A	Reserved for system.	
	SW01437 SW01439	SB014□□B	SYNCCOND	0: High-speed scan service synchronized 1: High-speed scan service not synchronized
	SW01441	SB014□□C	Reserved for system.	
		SB014□□D	STSTOPR	0: No operation stop request from other CPUs 1: Operation stop request from other CPUs
		SB014□□E	STOPREQ	Operation Stop Request from MPE720 0: RUN selected 1: STOP selected
		SB014□□F	RUNSW	Run Switch Status at Power ON 0: STOP 1: RUN

■ MPU-01 Module Circuit □ Error Status Detail

Name	Register Address	Description
MPU-01 Module Circuit □ Error Status	SB014□□0	CPUDOWN 0: Normal 1: Serious failure
	SB014□□1	Reserved for system.
	SB014□□2	Reserved for system.
	SB014□□3	EX_ERROR 0: Normal 1: EX error
	SB014□□4	SYNCERR 0: Synchronization normal 1: Synchronization error
	SB014□□5	Reserved for system.
	SB014□□6	Reserved for system.
	SB014□□7	Reserved for system.
	SB014□□8	UE_ERROR 0: Normal 1: User operation error
	SB014□□9	IO_ERROR 0: Normal 1: I/O error
	SB014□□A	Reserved for system.
	SB014□□B	SCAN_ERROR 0: Scan setting normal 1: Scan setting error
	SB014□□C	CPUSCANERR 0: Normal 1: Main CPU H scan restrictions error
	SB014□□D	MPUSCANERR 0: Normal 1: Restrictions error in MECHATROLINK-III communications cycle
	SB014□□E	Reserved for system.
	SB014□□F	Reserved for system.

◆ PROFINET Controller (266IF-01) IOPS Status Information

The IOPS status information for the PROFINET Controller (266IF-01) is stored in the following system registers.

Register Address	Remarks	
SW02688 to SW02695	Circuit 1	IOPS Output -
SW02696 to SW02749		IOPS Status The input IOPS status from the slaves (54 words) 0: Data disabled (BAD) 1: Data enabled (GOOD)
SW02750 to SW02751		Reserved for system. -
SW02752 to SW02815	Circuit 2	Same as above.
SW02816 to SW02879	Circuit 3	Same as above.
SW02880 to SW02943	Circuit 4	Same as above.
SW02944 to SW03007	Circuit 5	Same as above.
SW03008 to SW03071	Circuit 6	Same as above.
SW03072 to SW03135	Circuit 7	Same as above.
SW03136 to SW03199	Circuit 8	Same as above.

◆ Motion Program Execution Information

This section gives the system register configuration of and details on the motion program execution information.

■ Configuration of the System Registers

The execution status of the motion programs is stored in the following system registers.

Register Address	Name	Reference
SW03200	Number of Currently Executing Program for Work 1	–
SW03201	Number of Currently Executing Program for Work 2	–
SW03202	Number of Currently Executing Program for Work 3	–
SW03203	Number of Currently Executing Program for Work 4	–
SW03204	Number of Currently Executing Program for Work 5	–
SW03205	Number of Currently Executing Program for Work 6	–
SW03206	Number of Currently Executing Program for Work 7	–
SW03207	Number of Currently Executing Program for Work 8	–
SW03208	Number of Currently Executing Program for Work 9	–
SW03209	Number of Currently Executing Program for Work 10	–
SW03210	Number of Currently Executing Program for Work 11	–
SW03211	Number of Currently Executing Program for Work 12	–
SW03212	Number of Currently Executing Program for Work 13	–
SW03213	Number of Currently Executing Program for Work 14	–
SW03214	Number of Currently Executing Program for Work 15	–
SW03215	Number of Currently Executing Program for Work 16	–
SW03216	Number of Currently Executing Program for Work 17	–
SW03217	Number of Currently Executing Program for Work 18	–
SW03218	Number of Currently Executing Program for Work 19	–
SW03219	Number of Currently Executing Program for Work 20	–
SW03220	Number of Currently Executing Program for Work 21	–
SW03221	Number of Currently Executing Program for Work 22	–
SW03222	Number of Currently Executing Program for Work 23	–
SW03223	Number of Currently Executing Program for Work 24	–
SW03224	Number of Currently Executing Program for Work 25	–
SW03225	Number of Currently Executing Program for Work 26	–
SW03226	Number of Currently Executing Program for Work 27	–
SW03227	Number of Currently Executing Program for Work 28	–
SW03228	Number of Currently Executing Program for Work 29	–
SW03229	Number of Currently Executing Program for Work 30	–
SW03230	Number of Currently Executing Program for Work 31	–
SW03231	Number of Currently Executing Program for Work 32	–
SW03232 to SW03263	Program Running Bits	■ <i>Details on page 4-39</i>
SW03264 to SW03321	Work 1 Program Information	• <i>System Work Numbers 1 to 8 on page 4-40</i>
SW03322 to SW03379	Work 2 Program Information	
SW03380 to SW03437	Work 3 Program Information	
SW03438 to SW03495	Work 4 Program Information	
SW03496 to SW03553	Work 5 Program Information	
SW03554 to SW03611	Work 6 Program Information	
SW03612 to SW03669	Work 7 Program Information	
SW03670 to SW03727	Work 8 Program Information	

Continued on next page.

Continued from previous page.

Register Address	Name	Reference
SW03728 to SW03785	Work 9 Program Information	• System Work Numbers 9 to 16 on page 4-42
SW03786 to SW03843	Work 10 Program Information	
SW03844 to SW03901	Work 11 Program Information	
SW03902 to SW03959	Work 12 Program Information	
SW03960 to SW04017	Work 13 Program Information	
SW04018 to SW04075	Work 14 Program Information	
SW04076 to SW04133	Work 15 Program Information	
SW04134 to SW04191	Work 16 Program Information	
SW04192 to SW04249	Work 17 Program Information	• System Work Numbers 17 to 24 on page 4-44
SW04250 to SW04307	Work 18 Program Information	
SW04308 to SW04365	Work 19 Program Information	
SW04366 to SW04423	Work 20 Program Information	
SW04424 to SW04481	Work 21 Program Information	
SW04482 to SW04539	Work 22 Program Information	
SW04540 to SW04597	Work 23 Program Information	
SW04598 to SW04655	Work 24 Program Information	
SW04656 to SW04713	Work 25 Program Information	• System Work Numbers 25 to 32 on page 4-46
SW04714 to SW04771	Work 26 Program Information	
SW04772 to SW04829	Work 27 Program Information	
SW04830 to SW04887	Work 28 Program Information	
SW04888 to SW04945	Work 29 Program Information	
SW04946 to SW05003	Work 30 Program Information	
SW05004 to SW05061	Work 31 Program Information	
SW05062 to SW05119	Work 32 Program Information	
SW08192 to SW08223	Work 1 Extended Program Information	• System Work Numbers 1 to 8 on page 4-40
SW08224 to SW08255	Work 2 Extended Program Information	
SW08256 to SW08287	Work 3 Extended Program Information	
SW08288 to SW08319	Work 4 Extended Program Information	
SW08320 to SW08351	Work 5 Extended Program Information	
SW08352 to SW08383	Work 6 Extended Program Information	
SW08384 to SW08415	Work 7 Extended Program Information	
SW08416 to SW08447	Work 8 Extended Program Information	
SW08448 to SW08479	Work 9 Extended Program Information	• System Work Numbers 9 to 16 on page 4-42
SW08480 to SW08511	Work 10 Extended Program Information	
SW08512 to SW08543	Work 11 Extended Program Information	
SW08544 to SW08575	Work 12 Extended Program Information	
SW08576 to SW08607	Work 13 Extended Program Information	
SW08608 to SW08639	Work 14 Extended Program Information	
SW08640 to SW08671	Work 15 Extended Program Information	
SW08672 to SW08703	Work 16 Extended Program Information	
SW08704 to SW08735	Work 17 Extended Program Information	• System Work Numbers 17 to 24 on page 4-44
SW08736 to SW08767	Work 18 Extended Program Information	
SW08768 to SW08799	Work 19 Extended Program Information	
SW08800 to SW08831	Work 20 Extended Program Information	
SW08832 to SW08863	Work 21 Extended Program Information	
SW08864 to SW08895	Work 22 Extended Program Information	
SW08896 to SW08927	Work 23 Extended Program Information	
SW08928 to SW08959	Work 24 Extended Program Information	

Continued on next page.

4.2 CPU Module Specifications

4.2.7 System Register Specifications

Continued from previous page.

Register Address	Name	Reference
SW08960 to SW08991	Work 25 Extended Program Information	• <i>System Work Numbers 25 to 32 on page 4-46</i>
SW08992 to SW09023	Work 26 Extended Program Information	
SW09024 to SW09055	Work 27 Extended Program Information	
SW09056 to SW09087	Work 28 Extended Program Information	
SW09088 to SW09119	Work 29 Extended Program Information	
SW09120 to SW09151	Work 30 Extended Program Information	
SW09152 to SW09183	Work 31 Extended Program Information	
SW09184 to SW09215	Work 32 Extended Program Information	

■ Details

The following table gives details on the Program Execution Bits from system register addresses SW03232 to SW03263.

The program is being executed when the corresponding bit is 1.

Register Address	Description
SW03232	MP□016 (Bit F) to MP□001 (Bit 0)
SW03233	MP□032 (Bit F) to MP□017 (Bit 0)
SW03234	MP□048 (Bit F) to MP□033 (Bit 0)
SW03235	MP□064 (Bit F) to MP□049 (Bit 0)
SW03236	MP□080 (Bit F) to MP□065 (Bit 0)
SW03237	MP□096 (Bit F) to MP□081 (Bit 0)
SW03238	MP□112 (Bit F) to MP□097 (Bit 0)
SW03239	MP□128 (Bit F) to MP□113 (Bit 0)
SW03240	MP□144 (Bit F) to MP□129 (Bit 0)
SW03241	MP□160 (Bit F) to MP□145 (Bit 0)
SW03242	MP□176 (Bit F) to MP□161 (Bit 0)
SW03243	MP□192 (Bit F) to MP□177 (Bit 0)
SW03244	MP□208 (Bit F) to MP□193 (Bit 0)
SW03245	MP□224 (Bit F) to MP□209 (Bit 0)
SW03246	MP□240 (Bit F) to MP□225 (Bit 0)
SW03247	MP□256 (Bit F) to MP□241 (Bit 0)
SW03248	MP□272 (Bit F) to MP□257 (Bit 0)
SW03249	MP□288 (Bit F) to MP□273 (Bit 0)
SW03250	MP□304 (Bit F) to MP□289 (Bit 0)
SW03251	MP□320 (Bit F) to MP□305 (Bit 0)
SW03252	MP□336 (Bit F) to MP□321 (Bit 0)
SW03253	MP□352 (Bit F) to MP□337 (Bit 0)
SW03254	MP□368 (Bit F) to MP□353 (Bit 0)
SW03255	MP□384 (Bit F) to MP□369 (Bit 0)
SW03256	MP□400 (Bit F) to MP□385 (Bit 0)
SW03257	MP□416 (Bit F) to MP□401 (Bit 0)
SW03258	MP□432 (Bit F) to MP□417 (Bit 0)
SW03259	MP□448 (Bit F) to MP□433 (Bit 0)
SW03260	MP□464 (Bit F) to MP□449 (Bit 0)
SW03261	MP□480 (Bit F) to MP□465 (Bit 0)
SW03262	MP□496 (Bit F) to MP□481 (Bit 0)
SW03263	MP□512 (Bit F) to MP□497 (Bit 0)

■ System Registers Used for System Work Numbers 1 to 32

The system registers that are used for system work numbers 1 to 32 are given in the following table.

Two system registers are given in the register table for the alarm code, but we recommend that you use system registers SL26□□□. You can use the system registers that are given in parentheses to check for alarms in most cases, but they do not report all alarms.

Refer to the following manual for details on alarm codes.

📖 MP3000 Series Machine Controller System Troubleshooting Manual (Manual No.: S1EP C880725 01)

- System Work Numbers 1 to 8

System Work Number	Work 1	Work 2	Work 3	Work 4	Work 5	Work 6	Work 7	Work 8	
Executing Main Program No.	SW03200	SW03201	SW03202	SW03203	SW03204	SW03205	SW03206	SW03207	
Status	SW03264	SW03322	SW03380	SW03438	SW03496	SW03554	SW03612	SW03670	
Control Signals	SW03265	SW03323	SW03381	SW03439	SW03497	SW03555	SW03613	SW03671	
Fork 0	Program Number	SW03266	SW03324	SW03382	SW03440	SW03498	SW03556	SW03614	SW03672
	Block Number	SW03267	SW03325	SW03383	SW03441	SW03499	SW03557	SW03615	SW03673
	Alarm Code	SL26000 (SW03268)	SL26016 (SW03326)	SL26032 (SW03384)	SL26048 (SW03442)	SL26064 (SW03500)	SL26080 (SW03558)	SL26096 (SW03616)	SL26112 (SW03674)
Fork 1	Program Number	SW03269	SW03327	SW03385	SW03443	SW03501	SW03559	SW03617	SW03675
	Block Number	SW03270	SW03328	SW03386	SW03444	SW03502	SW03560	SW03618	SW03676
	Alarm Code	SL26002 (SW03271)	SL26018 (SW03329)	SL26034 (SW03387)	SL26050 (SW03445)	SL26066 (SW03503)	SL26082 (SW03561)	SL26098 (SW03619)	SL26114 (SW03677)
Fork 2	Program Number	SW03272	SW03330	SW03388	SW03446	SW03504	SW03562	SW03620	SW03678
	Block Number	SW03273	SW03331	SW03389	SW03447	SW03505	SW03563	SW03621	SW03679
	Alarm Code	SL26004 (SW03274)	SL26020 (SW03332)	SL26036 (SW03390)	SL26052 (SW03448)	SL26068 (SW03506)	SL26084 (SW03564)	SL26100 (SW03622)	SL26116 (SW03680)
Fork 3	Program Number	SW03275	SW03333	SW03391	SW03449	SW03507	SW03565	SW03623	SW03681
	Block Number	SW03276	SW03334	SW03392	SW03450	SW03508	SW03566	SW03624	SW03682
	Alarm Code	SL26006 (SW03277)	SL26022 (SW03335)	SL26038 (SW03393)	SL26054 (SW03451)	SL26070 (SW03509)	SL26086 (SW03567)	SL26102 (SW03625)	SL26118 (SW03683)
Fork 4	Program Number	SW03278	SW03336	SW03394	SW03452	SW03510	SW03568	SW03626	SW03684
	Block Number	SW03279	SW03337	SW03395	SW03453	SW03511	SW03569	SW03627	SW03685
	Alarm Code	SL26008 (SW03280)	SL26024 (SW03338)	SL26040 (SW03396)	SL26056 (SW03454)	SL26072 (SW03512)	SL26088 (SW03570)	SL26104 (SW03628)	SL26120 (SW03686)
Fork 5	Program Number	SW03281	SW03339	SW03397	SW03455	SW03513	SW03571	SW03629	SW03687
	Block Number	SW03282	SW03340	SW03398	SW03456	SW03514	SW03572	SW03630	SW03688
	Alarm Code	SL26010 (SW03283)	SL26026 (SW03341)	SL26042 (SW03399)	SL26058 (SW03457)	SL26074 (SW03515)	SL26090 (SW03573)	SL26106 (SW03631)	SL26122 (SW03689)
Fork 6	Program Number	SW03284	SW03342	SW03400	SW03458	SW03516	SW03574	SW03632	SW03690
	Block Number	SW03285	SW03343	SW03401	SW03459	SW03517	SW03575	SW03633	SW03691
	Alarm Code	SL26012 (SW03286)	SL26028 (SW03344)	SL26044 (SW03402)	SL26060 (SW03460)	SL26076 (SW03518)	SL26092 (SW03576)	SL26108 (SW03634)	SL26124 (SW03692)
Fork 7	Program Number	SW03287	SW03345	SW03403	SW03461	SW03519	SW03577	SW03635	SW03693
	Block Number	SW03288	SW03346	SW03404	SW03462	SW03520	SW03578	SW03636	SW03694
	Alarm Code	SL260014 (SW03289)	SL26030 (SW03347)	SL26046 (SW03405)	SL26062 (SW03463)	SL26078 (SW03521)	SL26094 (SW03579)	SL26110 (SW03637)	SL26126 (SW03695)
Logical Axis 1 Program Current Position	SL03290	SL03348	SL03406	SL03464	SL03522	SL03580	SL03638	SL03696	
Logical Axis 2 Program Current Position	SL03292	SL03350	SL03408	SL03466	SL03524	SL03582	SL03640	SL03698	
Logical Axis 3 Program Current Position	SL03294	SL03352	SL03410	SL03468	SL03526	SL03584	SL03642	SL03700	
Logical Axis 4 Program Current Position	SL03296	SL03354	SL03412	SL03470	SL03528	SL03586	SL03644	SL03702	
Logical Axis 5 Program Current Position	SL03298	SL03356	SL03414	SL03472	SL03530	SL03588	SL03646	SL03704	

Continued on next page.

Continued from previous page.

System Work Number	Work 1	Work 2	Work 3	Work 4	Work 5	Work 6	Work 7	Work 8
Logical Axis 6 Program Current Position	SL03300	SL03358	SL03416	SL03474	SL03532	SL03590	SL03648	SL03706
Logical Axis 7 Program Current Position	SL03302	SL03360	SL03418	SL03476	SL03534	SL03592	SL03650	SL03708
Logical Axis 8 Program Current Position	SL03304	SL03362	SL03420	SL03478	SL03536	SL03594	SL03652	SL03710
Logical Axis 9 Program Current Position	SL03306	SL03364	SL03422	SL03480	SL03538	SL03596	SL03654	SL03712
Logical Axis 10 Program Current Position	SL03308	SL03366	SL03424	SL03482	SL03540	SL03598	SL03656	SL03714
Logical Axis 11 Program Current Position	SL03310	SL03368	SL03426	SL03484	SL03542	SL03600	SL03658	SL03716
Logical Axis 12 Program Current Position	SL03312	SL03370	SL03428	SL03486	SL03544	SL03602	SL03660	SL03718
Logical Axis 13 Program Current Position	SL03314	SL03372	SL03430	SL03488	SL03546	SL03604	SL03662	SL03720
Logical Axis 14 Program Current Position	SL03316	SL03374	SL03432	SL03490	SL03548	SL03606	SL03664	SL03722
Logical Axis 15 Program Current Position	SL03318	SL03376	SL03434	SL03492	SL03550	SL03608	SL03666	SL03724
Logical Axis 16 Program Current Position	SL03320	SL03378	SL03436	SL03494	SL03552	SL03610	SL03668	SL03726
Logical Axis 17 Program Current Position	SL08192	SL08224	SL08256	SL08288	SL08320	SL08352	SL08384	SL08416
Logical Axis 18 Program Current Position	SL08194	SL08226	SL08258	SL08290	SL08322	SL08354	SL08386	SL08418
Logical Axis 19 Program Current Position	SL08196	SL08228	SL08260	SL08292	SL08324	SL08356	SL08388	SL08420
Logical Axis 20 Program Current Position	SL08198	SL08230	SL08262	SL08294	SL08326	SL08358	SL08390	SL08422
Logical Axis 21 Program Current Position	SL08200	SL08232	SL08264	SL08296	SL08328	SL08360	SL08392	SL08424
Logical Axis 22 Program Current Position	SL08202	SL08234	SL08266	SL08298	SL08330	SL08362	SL08394	SL08426
Logical Axis 23 Program Current Position	SL08204	SL08236	SL08268	SL08300	SL08332	SL08364	SL08396	SL08428
Logical Axis 24 Program Current Position	SL08206	SL08238	SL08270	SL08302	SL08334	SL08366	SL08398	SL08430
Logical Axis 25 Program Current Position	SL08208	SL08240	SL08272	SL08304	SL08336	SL08368	SL08400	SL08432
Logical Axis 26 Program Current Position	SL08210	SL08242	SL08274	SL08306	SL08338	SL08370	SL08402	SL08434
Logical Axis 27 Program Current Position	SL08212	SL08244	SL08276	SL08308	SL08340	SL08372	SL08404	SL08436
Logical Axis 28 Program Current Position	SL08214	SL08246	SL08278	SL08310	SL08342	SL08374	SL08406	SL08438
Logical Axis 29 Program Current Position	SL08216	SL08248	SL08280	SL08312	SL08344	SL08376	SL08408	SL08440
Logical Axis 30 Program Current Position	SL08218	SL08250	SL08282	SL08314	SL08346	SL08378	SL08410	SL08442
Logical Axis 31 Program Current Position	SL08220	SL08252	SL08284	SL08316	SL08348	SL08380	SL08412	SL08444
Logical Axis 32 Program Current Position	SL08222	SL08254	SL08286	SL08318	SL08350	SL08382	SL08414	SL08446

4.2 CPU Module Specifications

4.2.7 System Register Specifications

- System Work Numbers 9 to 16

System Work Number	Work 9	Work 10	Work 11	Work 12	Work 13	Work 14	Work 15	Work 16	
Executing Main Program No.	SW03208	SW03209	SW03210	SW03211	SW03212	SW03213	SW03214	SW03215	
Status	SW03728	SW03786	SW03844	SW03902	SW03960	SW04018	SW04076	SW04134	
Control Signals	SW03729	SW03787	SW03845	SW03903	SW03961	SW04019	SW04077	SW04135	
Fork 0	Program Number	SW03730	SW03788	SW03846	SW03904	SW03962	SW04020	SW04078	SW04136
	Block Number	SW03731	SW03789	SW03847	SW03905	SW03963	SW04021	SW04079	SW04137
	Alarm Code	SL26128 (SW03732)	SL26144 (SW03790)	SL26160 (SW03848)	SL26176 (SW03906)	SL26192 (SW03964)	SL26208 (SW04022)	SL26224 (SW04080)	SL26240 (SW04138)
Fork 1	Program Number	SW03733	SW03791	SW03849	SW03907	SW03965	SW04023	SW04081	SW04139
	Block Number	SW03734	SW03792	SW03850	SW03908	SW03966	SW04024	SW04082	SW04140
	Alarm Code	SL26130 (SW03735)	SL26146 (SW03793)	SL26162 (SW03851)	SL26178 (SW03909)	SL26194 (SW03967)	SL26210 (SW04025)	SL26226 (SW04083)	SL26242 (SW04141)
Fork 2	Program Number	SW03736	SW03794	SW03852	SW03910	SW03968	SW04026	SW04084	SW04142
	Block Number	SW03737	SW03795	SW03853	SW03911	SW03969	SW04027	SW04085	SW04143
	Alarm Code	SL26132 (SW03738)	SL26148 (SW03796)	SL26164 (SW03854)	SL26180 (SW03912)	SL26196 (SW03970)	SL26212 (SW04028)	SL26228 (SW04086)	SL26244 (SW04144)
Fork 3	Program Number	SW03739	SW03797	SW03855	SW03913	SW03971	SW04029	SW04087	SW04145
	Block Number	SW03740	SW03798	SW03856	SW03914	SW03972	SW04030	SW04088	SW04146
	Alarm Code	SL26134 (SW03741)	SL26150 (SW03799)	SL26166 (SW03857)	SL26182 (SW03915)	SL26198 (SW03973)	SL26214 (SW04031)	SL26230 (SW04089)	SL26246 (SW04147)
Fork 4	Program Number	SW03742	SW03800	SW03858	SW03916	SW03974	SW04032	SW04090	SW04148
	Block Number	SW03743	SW03801	SW03859	SW03917	SW03975	SW04033	SW04091	SW04149
	Alarm Code	SL26136 (SW03744)	SL26152 (SW03802)	SL26168 (SW03860)	SL26184 (SW03918)	SL26200 (SW03976)	SL26216 (SW04034)	SL26232 (SW04092)	SL26248 (SW04150)
Fork 5	Program Number	SW03745	SW03803	SW03861	SW03919	SW03977	SW04035	SW04093	SW04151
	Block Number	SW03746	SW03804	SW03862	SW03920	SW03978	SW04036	SW04094	SW04152
	Alarm Code	SL26138 (SW03747)	SL26154 (SW03805)	SL26170 (SW03863)	SL26186 (SW03921)	SL26202 (SW03979)	SL26218 (SW04037)	SL26234 (SW04095)	SL26250 (SW04153)
Fork 6	Program Number	SW03748	SW03806	SW03864	SW03922	SW03980	SW04038	SW04096	SW04154
	Block Number	SW03749	SW03807	SW03865	SW03923	SW03981	SW04039	SW04097	SW04155
	Alarm Code	SL26140 (SW03750)	SL26156 (SW03808)	SL26172 (SW03866)	SL26188 (SW03924)	SL26204 (SW03982)	SL26220 (SW04040)	SL26236 (SW04098)	SL26252 (SW04156)
Fork 7	Program Number	SW03751	SW03809	SW03867	SW03925	SW03983	SW04041	SW04099	SW04157
	Block Number	SW03752	SW03810	SW03868	SW03926	SW03984	SW04042	SW04100	SW04158
	Alarm Code	SL26142 (SW03753)	SL26158 (SW03811)	SL26174 (SW03869)	SL26190 (SW03927)	SL26206 (SW03985)	SL26222 (SW04043)	SL26238 (SW04101)	SL26254 (SW04159)
Logical Axis 1 Program Current Position	SL03754	SL03812	SL03870	SL03928	SL03986	SL04044	SL04102	SL04160	
Logical Axis 2 Program Current Position	SL03756	SL03814	SL03872	SL03930	SL03988	SL04046	SL04104	SL04162	
Logical Axis 3 Program Current Position	SL03758	SL03816	SL03874	SL03932	SL03990	SL04048	SL04106	SL04164	
Logical Axis 4 Program Current Position	SL03760	SL03818	SL03876	SL03934	SL03992	SL04050	SL04108	SL04166	
Logical Axis 5 Program Current Position	SL03762	SL03820	SL03878	SL03936	SL03994	SL04052	SL04110	SL04168	
Logical Axis 6 Program Current Position	SL03764	SL03822	SL03880	SL03938	SL03996	SL04054	SL04112	SL04170	
Logical Axis 7 Program Current Position	SL03766	SL03824	SL03882	SL03940	SL03998	SL04056	SL04114	SL04172	
Logical Axis 8 Program Current Position	SL03768	SL03826	SL03884	SL03942	SL04000	SL04058	SL04116	SL04174	

Continued on next page.

Continued from previous page.

System Work Number	Work 9	Work 10	Work 11	Work 12	Work 13	Work 14	Work 15	Work 16
Logical Axis 9 Program Current Position	SL03770	SL03828	SL03886	SL03944	SL04002	SL04060	SL04118	SL04176
Logical Axis 10 Program Current Position	SL03772	SL03830	SL03888	SL03946	SL04004	SL04062	SL04120	SL04178
Logical Axis 11 Program Current Position	SL03774	SL03832	SL03890	SL03948	SL04006	SL04064	SL04122	SL04180
Logical Axis 12 Program Current Position	SL03776	SL03834	SL03892	SL03950	SL04008	SL04066	SL04124	SL04182
Logical Axis 13 Program Current Position	SL03778	SL03836	SL03894	SL03952	SL04010	SL04068	SL04126	SL04184
Logical Axis 14 Program Current Position	SL03780	SL03838	SL03896	SL03954	SL04012	SL04070	SL04128	SL04186
Logical Axis 15 Program Current Position	SL03782	SL03840	SL03898	SL03956	SL04014	SL04072	SL04130	SL04188
Logical Axis 16 Program Current Position	SL03784	SL03842	SL03900	SL03958	SL04016	SL04074	SL04132	SL04190
Logical Axis 17 Program Current Position	SL08448	SL08480	SL08512	SL08544	SL08576	SL08608	SL08640	SL08672
Logical Axis 18 Program Current Position	SL08450	SL08482	SL08514	SL08546	SL08578	SL08610	SL08642	SL08674
Logical Axis 19 Program Current Position	SL08452	SL08484	SL08516	SL08548	SL08580	SL08612	SL08644	SL08676
Logical Axis 20 Program Current Position	SL08454	SL08486	SL08518	SL08550	SL08582	SL08614	SL08646	SL08678
Logical Axis 21 Program Current Position	SL08456	SL08488	SL08520	SL08552	SL08584	SL08616	SL08648	SL08680
Logical Axis 22 Program Current Position	SL08458	SL08490	SL08522	SL08554	SL08586	SL08618	SL08650	SL08682
Logical Axis 23 Program Current Position	SL08460	SL08492	SL08524	SL08556	SL08588	SL08620	SL08652	SL08684
Logical Axis 24 Program Current Position	SL08462	SL08494	SL08526	SL08558	SL08590	SL08622	SL08654	SL08686
Logical Axis 25 Program Current Position	SL08464	SL08496	SL08528	SL08560	SL08592	SL08624	SL08656	SL08688
Logical Axis 26 Program Current Position	SL08466	SL08498	SL08530	SL08562	SL08594	SL08626	SL08658	SL08690
Logical Axis 27 Program Current Position	SL08468	SL08500	SL08532	SL08564	SL08596	SL08628	SL08660	SL08692
Logical Axis 28 Program Current Position	SL08470	SL08502	SL08534	SL08566	SL08598	SL08630	SL08662	SL08694
Logical Axis 29 Program Current Position	SL08472	SL08504	SL08536	SL08568	SL08600	SL08632	SL08664	SL08696
Logical Axis 30 Program Current Position	SL08474	SL08506	SL08538	SL08570	SL08602	SL08634	SL08666	SL08698
Logical Axis 31 Program Current Position	SL08476	SL08508	SL08540	SL08572	SL08604	SL08636	SL08668	SL08700
Logical Axis 32 Program Current Position	SL08478	SL08510	SL08542	SL08574	SL08606	SL08638	SL08670	SL08702

4.2 CPU Module Specifications

4.2.7 System Register Specifications

- System Work Numbers 17 to 24

System Work Number	Work 17	Work 18	Work 19	Work 20	Work 21	Work 22	Work 23	Work 24	
Executing Main Program No.	SW03216	SW03217	SW03218	SW03219	SW03220	SW03221	SW03222	SW03223	
Status	SW04192	SW04250	SW04308	SW04366	SW04424	SW04482	SW04540	SW04598	
Control Signals	SW04193	SW04251	SW04309	SW04367	SW04425	SW04483	SW04541	SW04599	
Fork 0	Program Number	SW04194	SW04252	SW04310	SW04368	SW04426	SW04484	SW04542	SW04600
	Block Number	SW04195	SW04253	SW04311	SW04369	SW04427	SW04485	SW04543	SW04601
	Alarm Code	SL26256 (SW04196)	SL26272 (SW04254)	SL26288 (SW04312)	SL26304 (SW04370)	SL26320 (SW04428)	SL26336 (SW04486)	SL26352 (SW04544)	SL26368 (SW04602)
Fork 1	Program Number	SW04197	SW04255	SW04313	SW04371	SW04429	SW04487	SW04545	SW04603
	Block Number	SW04198	SW04256	SW04314	SW04372	SW04430	SW04488	SW04546	SW04604
	Alarm Code	SL26258 (SW04199)	SL26274 (SW04257)	SL26290 (SW04315)	SL26306 (SW04373)	SL26322 (SW04431)	SL26338 (SW04489)	SL26354 (SW04547)	SL26370 (SW04605)
Fork 2	Program Number	SW04200	SW04258	SW04316	SW04374	SW04432	SW04490	SW04548	SW04606
	Block Number	SW04201	SW04259	SW04317	SW04375	SW04433	SW04491	SW04549	SW04607
	Alarm Code	SL26260 (SW04202)	SL26276 (SW04260)	SL26292 (SW04318)	SL26308 (SW04376)	SL26324 (SW04434)	SL26340 (SW04492)	SL26356 (SW04550)	SL26372 (SW04608)
Fork 3	Program Number	SW04203	SW04261	SW04319	SW04377	SW04435	SW04493	SW04551	SW04609
	Block Number	SW04204	SW04262	SW04320	SW04378	SW04436	SW04494	SW04552	SW04610
	Alarm Code	SL26262 (SW04205)	SL26278 (SW04263)	SL26294 (SW04321)	SL26310 (SW04379)	SL26326 (SW04437)	SL26342 (SW04495)	SL26358 (SW04553)	SL26374 (SW04611)
Fork 4	Program Number	SW04206	SW04264	SW04322	SW04380	SW04438	SW04496	SW04554	SW04612
	Block Number	SW04207	SW04265	SW04323	SW04381	SW04439	SW04497	SW04555	SW04613
	Alarm Code	SL26264 (SW04208)	SL26280 (SW04266)	SL26296 (SW04324)	SL26312 (SW04382)	SL26328 (SW04440)	SL26344 (SW04498)	SL26360 (SW04556)	SL26376 (SW04614)
Fork 5	Program Number	SW04209	SW04267	SW04325	SW04383	SW04441	SW04499	SW04557	SW04615
	Block Number	SW04210	SW04268	SW04326	SW04384	SW04442	SW04500	SW04558	SW04616
	Alarm Code	SL26266 (SW04211)	SL26282 (SW04269)	SL26298 (SW04327)	SL26314 (SW04385)	SL26330 (SW04443)	SL26346 (SW04501)	SL26362 (SW04559)	SL26378 (SW04617)
Fork 6	Program Number	SW04212	SW04270	SW04328	SW04386	SW04444	SW04502	SW04560	SW04618
	Block Number	SW04213	SW04271	SW04329	SW04387	SW04445	SW04503	SW04561	SW04619
	Alarm Code	SL26268 (SW04214)	SL26284 (SW04272)	SL26300 (SW04330)	SL26316 (SW04388)	SL26332 (SW04446)	SL26348 (SW04504)	SL26364 (SW04562)	SL26380 (SW04620)
Fork 7	Program Number	SW04215	SW04273	SW04331	SW04389	SW04447	SW04505	SW04563	SW04621
	Block Number	SW04216	SW04274	SW04332	SW04390	SW04448	SW04506	SW04564	SW04622
	Alarm Code	SL26270 (SW04217)	SL26286 (SW04275)	SL26302 (SW04333)	SL26318 (SW04391)	SL26334 (SW04449)	SL26350 (SW04507)	SL26366 (SW04565)	SL26382 (SW04623)
Logical Axis 1 Program Current Position	SL04218	SL04276	SL04334	SL04392	SL04450	SL04508	SL04566	SL04624	
Logical Axis 2 Program Current Position	SL04220	SL04278	SL04336	SL04394	SL04452	SL04510	SL04568	SL04626	
Logical Axis 3 Program Current Position	SL04222	SL04280	SL04338	SL04396	SL04454	SL04512	SL04570	SL04628	
Logical Axis 4 Program Current Position	SL04224	SL04282	SL04340	SL04398	SL04456	SL04514	SL04572	SL04630	
Logical Axis 5 Program Current Position	SL04226	SL04284	SL04342	SL04400	SL04458	SL04516	SL04574	SL04632	
Logical Axis 6 Program Current Position	SL04228	SL04286	SL04344	SL04402	SL04460	SL04518	SL04576	SL04634	
Logical Axis 7 Program Current Position	SL04230	SL04288	SL04346	SL04404	SL04462	SL04520	SL04578	SL04636	
Logical Axis 8 Program Current Position	SL04232	SL04290	SL04348	SL04406	SL04464	SL04522	SL04580	SL04638	

Continued on next page.

Continued from previous page.

System Work Number	Work 17	Work 18	Work 19	Work 20	Work 21	Work 22	Work 23	Work 24
Logical Axis 9 Program Current Position	SL04234	SL04292	SL04350	SL04408	SL04466	SL04524	SL04582	SL04640
Logical Axis 10 Program Current Position	SL04236	SL04294	SL04352	SL04410	SL04468	SL04526	SL04584	SL04642
Logical Axis 11 Program Current Position	SL04238	SL04296	SL04354	SL04412	SL04470	SL04528	SL04586	SL04644
Logical Axis 12 Program Current Position	SL04240	SL04298	SL04356	SL04414	SL04472	SL04530	SL04588	SL04646
Logical Axis 13 Program Current Position	SL04242	SL04300	SL04358	SL04416	SL04474	SL04532	SL04590	SL04648
Logical Axis 14 Program Current Position	SL04244	SL04302	SL04360	SL04418	SL04476	SL04534	SL04592	SL04650
Logical Axis 15 Program Current Position	SL04246	SL04304	SL04362	SL04420	SL04478	SL04536	SL04594	SL04652
Logical Axis 16 Program Current Position	SL04248	SL04306	SL04364	SL04422	SL04480	SL04538	SL04596	SL04654
Logical Axis 17 Program Current Position	SL08704	SL08736	SL08768	SL08800	SL08832	SL08864	SL08896	SL08928
Logical Axis 18 Program Current Position	SL08706	SL08738	SL08770	SL08802	SL08834	SL08866	SL08898	SL08930
Logical Axis 19 Program Current Position	SL08708	SL08740	SL08772	SL08804	SL08836	SL08868	SL08900	SL08932
Logical Axis 20 Program Current Position	SL08710	SL08742	SL08774	SL08806	SL08838	SL08870	SL08902	SL08934
Logical Axis 21 Program Current Position	SL08712	SL08744	SL08776	SL08808	SL08840	SL08872	SL08904	SL08936
Logical Axis 22 Program Current Position	SL08714	SL08746	SL08778	SL08810	SL08842	SL08874	SL08906	SL08938
Logical Axis 23 Program Current Position	SL08716	SL08748	SL08780	SL08812	SL08844	SL08876	SL08908	SL08940
Logical Axis 24 Program Current Position	SL08718	SL08750	SL08782	SL08814	SL08846	SL08878	SL08910	SL08942
Logical Axis 25 Program Current Position	SL08720	SL08752	SL08784	SL08816	SL08848	SL08880	SL08912	SL08944
Logical Axis 26 Program Current Position	SL08722	SL08754	SL08786	SL08818	SL08850	SL08882	SL08914	SL08946
Logical Axis 27 Program Current Position	SL08724	SL08756	SL08788	SL08820	SL08852	SL08884	SL08916	SL08948
Logical Axis 28 Program Current Position	SL08726	SL08758	SL08790	SL08822	SL08854	SL08886	SL08918	SL08950
Logical Axis 29 Program Current Position	SL08728	SL08760	SL08792	SL08824	SL08856	SL08888	SL08920	SL08952
Logical Axis 30 Program Current Position	SL08730	SL08762	SL08794	SL08826	SL08858	SL08890	SL08922	SL08954
Logical Axis 31 Program Current Position	SL08732	SL08764	SL08796	SL08828	SL08860	SL08892	SL08924	SL08956
Logical Axis 32 Program Current Position	SL08734	SL08766	SL08798	SL08830	SL08862	SL08894	SL08926	SL08958

4.2 CPU Module Specifications

4.2.7 System Register Specifications

- System Work Numbers 25 to 32

System Work Number	Work 25	Work 26	Work 27	Work 28	Work 29	Work 30	Work 31	Work 32	
Executing Main Program No.	SW03224	SW03225	SW03226	SW03227	SW03228	SW03229	SW03230	SW03231	
Status	SW04656	SW04714	SW04772	SW04830	SW04888	SW04946	SW05004	SW05062	
Control Signals	SW04657	SW04715	SW04773	SW04831	SW04889	SW04947	SW05005	SW05063	
Fork 0	Program Number	SW04658	SW04716	SW04774	SW04832	SW04890	SW04948	SW05006	SW05064
	Block Number	SW04659	SW04717	SW04775	SW04833	SW04891	SW04949	SW05007	SW05065
	Alarm Code	SL26384 (SW04660)	SL26400 (SW04718)	SL26416 (SW04776)	SL26432 (SW04834)	SL26448 (SW04892)	SL26464 (SW04950)	SL26480 (SW05008)	SL26496 (SW05066)
Fork 1	Program Number	SW04661	SW04719	SW04777	SW04835	SW04893	SW04951	SW05009	SW05067
	Block Number	SW04662	SW04720	SW04778	SW04836	SW04894	SW04952	SW05010	SW05068
	Alarm Code	SL26386 (SW04663)	SL26402 (SW04721)	SL26418 (SW04779)	SL26434 (SW04837)	SL26450 (SW04895)	SL26466 (SW04953)	SL26482 (SW05011)	SL26498 (SW05069)
Fork 2	Program Number	SW04664	SW04722	SW04780	SW04838	SW04896	SW04954	SW05012	SW05070
	Block Number	SW04665	SW04723	SW04781	SW04839	SW04897	SW04955	SW05013	SW05071
	Alarm Code	SL26388 (SW04666)	SL26404 (SW04724)	SL26420 (SW04782)	SL26436 (SW04840)	SL26452 (SW04898)	SL26468 (SW04956)	SL26484 (SW05014)	SL26500 (SW05072)
Fork 3	Program Number	SW04667	SW04725	SW04783	SW04841	SW04899	SW04957	SW05015	SW05073
	Block Number	SW04668	SW04726	SW04784	SW04842	SW04900	SW04958	SW05016	SW05074
	Alarm Code	SL26390 (SW04669)	SL26406 (SW04727)	SL26422 (SW04785)	SL26438 (SW04843)	SL26454 (SW04901)	SL26470 (SW04959)	SL26486 (SW05017)	SL26502 (SW05075)
Fork 4	Program Number	SW04670	SW04728	SW04786	SW04844	SW04902	SW04960	SW05018	SW05076
	Block Number	SW04671	SW04729	SW04787	SW04845	SW04903	SW04961	SW05019	SW05077
	Alarm Code	SL26392 (SW04672)	SL26408 (SW04730)	SL26424 (SW04788)	SL26440 (SW04846)	SL26456 (SW04904)	SL26472 (SW04962)	SL26488 (SW05020)	SL26504 (SW05078)
Fork 5	Program Number	SW04673	SW04731	SW04789	SW04847	SW04905	SW04963	SW05021	SW05079
	Block Number	SW04674	SW04732	SW04790	SW04848	SW04906	SW04964	SW05022	SW05080
	Alarm Code	SL26394 (SW04675)	SL26410 (SW04733)	SL26426 (SW04791)	SL26442 (SW04849)	SL26458 (SW04907)	SL26474 (SW04965)	SL26490 (SW05023)	SL26506 (SW05081)
Fork 6	Program Number	SW04676	SW04734	SW04792	SW04850	SW04908	SW04966	SW05024	SW05082
	Block Number	SW04677	SW04735	SW04793	SW04851	SW04909	SW04967	SW05025	SW05083
	Alarm Code	SL26396 (SW04678)	SL26412 (SW04736)	SL26428 (SW04794)	SL26444 (SW04852)	SL26460 (SW04910)	SL26476 (SW04968)	SL26492 (SW05026)	SL26508 (SW05084)
Fork 7	Program Number	SW04679	SW04737	SW04795	SW04853	SW04911	SW04969	SW05027	SW05085
	Block Number	SW04680	SW04738	SW04796	SW04854	SW04912	SW04970	SW05028	SW05086
	Alarm Code	SL26398 (SW04681)	SL26414 (SW04739)	SL26430 (SW04797)	SL26446 (SW04855)	SL26462 (SW04913)	SL26478 (SW04971)	SL26494 (SW05029)	SL26510 (SW05087)
Logical Axis 1 Program Current Position	SL04682	SL04740	SL04798	SL04856	SL04914	SL04972	SL05030	SL05088	
Logical Axis 2 Program Current Position	SL04684	SL04742	SL04800	SL04858	SL04916	SL04974	SL05032	SL05090	
Logical Axis 3 Program Current Position	SL04686	SL04744	SL04802	SL04860	SL04918	SL04976	SL05034	SL05092	
Logical Axis 4 Program Current Position	SL04688	SL04746	SL04804	SL04862	SL04920	SL04978	SL05036	SL05094	
Logical Axis 5 Program Current Position	SL04690	SL04748	SL04806	SL04864	SL04922	SL04980	SL05038	SL05096	
Logical Axis 6 Program Current Position	SL04692	SL04750	SL04808	SL04866	SL04924	SL04982	SL05040	SL05098	
Logical Axis 7 Program Current Position	SL04694	SL04752	SL04810	SL04868	SL04926	SL04984	SL05042	SL05100	
Logical Axis 8 Program Current Position	SL04696	SL04754	SL04812	SL04870	SL04928	SL04986	SL05044	SL05102	

Continued on next page.

Continued from previous page.

System Work Number	Work 25	Work 26	Work 27	Work 28	Work 29	Work 30	Work 31	Work 32
Logical Axis 9 Program Current Position	SL04698	SL04756	SL04814	SL04872	SL04930	SL04988	SL05046	SL05104
Logical Axis 10 Program Current Position	SL04700	SL04758	SL04816	SL04874	SL04932	SL04990	SL05048	SL05106
Logical Axis 11 Program Current Position	SL04702	SL04760	SL04818	SL04876	SL04934	SL04992	SL05050	SL05108
Logical Axis 12 Program Current Position	SL04704	SL04762	SL04820	SL04878	SL04936	SL04994	SL05052	SL05110
Logical Axis 13 Program Current Position	SL04706	SL04764	SL04822	SL04880	SL04938	SL04996	SL05054	SL05112
Logical Axis 14 Program Current Position	SL04708	SL04766	SL04824	SL04882	SL04940	SL04998	SL05056	SL05114
Logical Axis 15 Program Current Position	SL04710	SL04768	SL04826	SL04884	SL04942	SL05000	SL05058	SL05116
Logical Axis 16 Program Current Position	SL04712	SL04770	SL04828	SL04886	SL04944	SL05002	SL05060	SL05118
Logical Axis 17 Program Current Position	SL08960	SL08992	SL09024	SL09056	SL09088	SL09120	SL09152	SL09184
Logical Axis 18 Program Current Position	SL08962	SL08994	SL09026	SL09058	SL09090	SL09122	SL09154	SL09186
Logical Axis 19 Program Current Position	SL08964	SL08996	SL09028	SL09060	SL09092	SL09124	SL09156	SL09188
Logical Axis 20 Program Current Position	SL08966	SL08998	SL09030	SL09062	SL09094	SL09126	SL09158	SL09190
Logical Axis 21 Program Current Position	SL08968	SL09000	SL09032	SL09064	SL09096	SL09128	SL09160	SL09192
Logical Axis 22 Program Current Position	SL08970	SL09002	SL09034	SL09066	SL09098	SL09130	SL09162	SL09194
Logical Axis 23 Program Current Position	SL08972	SL09004	SL09036	SL09068	SL09100	SL09132	SL09164	SL09196
Logical Axis 24 Program Current Position	SL08974	SL09006	SL09038	SL09070	SL09102	SL09134	SL09166	SL09198
Logical Axis 25 Program Current Position	SL08976	SL09008	SL09040	SL09072	SL09104	SL09136	SL09168	SL09200
Logical Axis 26 Program Current Position	SL08978	SL09010	SL09042	SL09074	SL09106	SL09138	SL09170	SL09202
Logical Axis 27 Program Current Position	SL08980	SL09012	SL09044	SL09076	SL09108	SL09140	SL09172	SL09204
Logical Axis 28 Program Current Position	SL08982	SL09014	SL09046	SL09078	SL09110	SL09142	SL09174	SL09206
Logical Axis 29 Program Current Position	SL08984	SL09016	SL09048	SL09080	SL09112	SL09144	SL09176	SL09208
Logical Axis 30 Program Current Position	SL08986	SL09018	SL09050	SL09082	SL09114	SL09146	SL09178	SL09210
Logical Axis 31 Program Current Position	SL08988	SL09020	SL09052	SL09084	SL09116	SL09148	SL09180	SL09212
Logical Axis 32 Program Current Position	SL08990	SL09022	SL09054	SL09086	SL09118	SL09150	SL09182	SL09214

◆ Expansion System Service Execution Status

The execution status of the system when the Units are expanded is stored in the following system registers.

Name	Register Address	Remarks
Data Trace Definition Existence	SB159980	Group 1
	SB159981	Group 2
	SB159982	Group 3
	SB159983	Group 4
	SB159984 to SB159987	Reserved for system.
Data Trace Enabled or Disabled Status	SB159988	Group 1
	SB159989	Group 2
	SB15998A	Group 3
	SB15998B	Group 4
	SB15998C to SB15998F	Reserved for system.
Data Trace Execution Status	SB159990	Group 1
	SB159991	Group 2
	SB159992	Group 3
	SB159993	Group 4
	SB159994 to SB159997	Reserved for system.
Data Trace Trigger Condition Status	SB159998	Group 1
	SB159999	Group 2
	SB15999A	Group 3
	SB15999B	Group 4
	SB15999C to SB15999F	Reserved for system.
Group 1 Record No.	SL16000	Latest record number in group 1.
Group 2 Record No.	SL16002	Latest record number in group 2.
Group 3 Record No.	SL16004	Latest record number in group 3.
Group 4 Record No.	SL16006	Latest record number in group 4.
Reserved for system.	SL16008	Reserved for system.
Reserved for system.	SL16010	Reserved for system.

◆ Alarm History Information

This section gives the system register configuration of and details on the alarm history information in the system registers.

■ Configuration of the System Registers



The alarm history information is stored in the following system registers.

Name	Register Address	Remarks
Current Alarm	SW16200	Cleared when the power is turned ON.
Alarm History Entries	SW16201	Alarm history entries
Alarm Clear	SW16202	1: Alarm cleared 2: Current alarm and history cleared
Alarm History	SW16203 to SW16218	Alarm History Entry 1
	SW16219 to SW16234	Alarm History Entry 2
	:	:
	SW17787 to SW17802	Alarm History Entry 100
Reserved for system.	SW17803 to SW17999	-

Refer to the following section for details.  ■ Details on page 4-49

■ Details

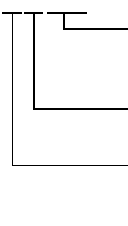
The system registers for the alarm history entries are structured as shown below. This example shows the system register addresses for alarm history entry 1.

Register Address	Remarks	Register Address Example
SW□□□□□ + 0	□□□□ hex  01 to 09: Gives the slot number where the Module in which the alarm occurred is mounted. 1 to 4: Gives the unit number of the Module in which the alarm occurred is mounted. 1 to 7: Gives the Rack number where the Module in which the alarm occurred is mounted.	SW16203
SW□□□□□ + 1	Alarm Code	SW16204
SW□□□□□ + 2	Alarm Detail Format 1: Operation error 2: I/O error 3: Other error	SW16205
SW□□□□□ + 3	Year when alarm occurred	SW16206
SW□□□□□ + 4	Month when alarm occurred	SW16207
SW□□□□□ + 5	Day when alarm occurred	SW16208
SW□□□□□ + 6	Hour when alarm occurred	SW16209
SW□□□□□ + 7	Minutes when alarm occurred	SW16210
SW□□□□□ + 8	Seconds when alarm occurred	SW16211
SW□□□□□ + 9	Alarm details The information depends on the alarm details format.  ■ Alarm details on page 4-49	SW16212
SW□□□□□ + 10		SW16213
SW□□□□□ + 11		SW16214
SW□□□□□ + 12		SW16215
SW□□□□□ + 13		SW16216
SW□□□□□ + 14	Reserved for system.	SW16217
SW□□□□□ + 15	Reserved for system.	SW16218

■ Alarm details

Alarm details are given based on the alarm details format.

- Alarm Detail Format = 1 (operation error)

Register Address	Remarks	Register Address Example
SW□□□□□ + 9	Error Drawing No.	SW16212
SW□□□□□ + 10	Calling Drawing No.	SW16213
SW□□□□□ + 11	Calling Drawing Step No.	SW16214
SW□□□□□ + 12	Reserved for system.	SW16215
SW□□□□□ + 13	Reserved for system.	SW16216

- Alarm Detail Format = 2 (I/O error)

Register Address	Remarks	Register Address Example
SW□□□□□ + 9	Depends on the specifications of the Optional Module.	SW16212
SW□□□□□ + 10	Depends on the specifications of the Optional Module.	SW16213
SW□□□□□ + 11	Depends on the specifications of the Optional Module.	SW16214
SW□□□□□ + 12	Depends on the specifications of the Optional Module.	SW16215
SW□□□□□ + 13	Depends on the specifications of the Optional Module.	SW16216

- Alarm Detail Format = 3 (other error)

Register Address	Remarks	Register Address Example
SW□□□□□ + 9	Reserved for system.	SW16212
SW□□□□□ + 10	Reserved for system.	SW16213
SW□□□□□ + 11	Reserved for system.	SW16214
SW□□□□□ + 12	Reserved for system.	SW16215
SW□□□□□ + 13	Reserved for system.	SW16216

◆ Product Information

The product information is stored in the following system registers.

Name	Register Address	Remarks
Serial ID Information	SW20000	CPU Module serial ID (15 ASCII characters + NULL character)
	SW20001	
	SW20002	
	SW20003	
	SW20004	
	SW20005	
	SW20006	
	SW20007	
Reserved for system.	SW20008 to SW20015	Reserved for system.
	SW20016 to SW22063	-

◆ Data Logging Execution Status

The execution status of data logging is stored in the following system registers.

Name	Register Address	Remarks	
Data Logging Definition Existence	SB240000	0: Logging 1 definition does not exist, 1: Logging 1 definition exists	
	SB240001	0: Logging 2 definition does not exist, 1: Logging 2 definition exists	
	SB240002	0: Logging 3 definition does not exist, 1: Logging 3 definition exists	
	SB240003	0: Logging 4 definition does not exist, 1: Logging 4 definition exists	
	SB240004 to SB24000F	Reserved for system.	
Data Logging Execution Status	SB240010	0: Logging 1 is in progress, 1: Logging 1 is stopped	
	SB240011	0: Logging 2 is in progress, 1: Logging 2 is stopped	
	SB240012	0: Logging 3 is in progress, 1: Logging 3 is stopped	
	SB240013	0: Logging 4 is in progress, 1: Logging 4 is stopped	
	SB240014 to SB240017	Reserved for system.	
	SB240018	0: Logging 1 is not waiting for trigger condition, 1: Logging 1 is waiting for trigger condition	
	SB240019	0: Logging 2 is not waiting for trigger condition, 1: Logging 2 is waiting for trigger condition	
	SB24001A	0: Logging 3 is not waiting for trigger condition, 1: Logging 3 is waiting for trigger condition	
	SB24001B	0: Logging 4 is not waiting for trigger condition, 1: Logging 4 is waiting for trigger condition	
	SB24001C to SB24001F	Reserved for system.	
Data Logging Execution Status Details	SL24002	File update counter	
	SQ24004	Latest record number	
	SW24008	Overrun counter	
	Logging 1	SW24009	Error Code 0000 hex: No error, 0001 hex: No USB memory device at start of logging, 0002 hex: No USB memory device while logging is in progress, 0003 hex: Directory creation error, 0004 hex: File creation error, 0005 hex: File write error 0006 hex: FTP transfer error
		SW24010 to SW24011	Reserved for system.
		SW24012 to SW24043	Latest folder name
		SW24044 to SW24065	Latest file name (includes extension such as □□□.csv)
	Logging 2	SW24066 to SW24129	Same as Logging 1.
	Logging 3	SW24130 to SW24193	Same as Logging 1.
	Logging 4	SW24194 to SW24257	Same as Logging 1.
Reserved for system.	SW24258 to SW24321	–	

◆ FTP Client Status and Control Information

The FTP client status and control information are stored in the following system registers.

Register Address	Remarks		
SW24400		SB244000	Reserved for system.
		SB244001	0: No session created. 1: Session created.
		SB244002	0: No connection. 1: Connection established.
		SB244003	0: Not logged in. 1: Logged in.
		SB244004	0: No upload in progress. 1: Upload in progress.
		SB244005	0: No download in progress. 1: Download in progress.
		SB244006 and SB244007	Reserved for system.
		SB244008	0: Active Mode 1: Passive Mode
		SB244009	0: Directory not created. 1: Directory created.
		SB24400A	0: No timeout. 1: Timed out.
		SB24400B to SB24400F	Reserved for system.
SW024401		Error Count	The value is incremented each time an error occurs.
SW024402		Error Processing Number	0001 hex: Session start processing 0002 hex: Connection processing 0003 hex: Login processing 0004 hex: Passive Mode change processing 0005 hex: Directory creation processing 0006 hex: STOR instruction processing 0007 hex: RETR instruction processing 0008 hex: Logout or disconnect processing 0009 hex: Close processing 000A hex: Session end processing
SW24403			Reserved for system.
SL24404			Used by the system.
SW24406 to SW24415			Reserved for system.
SW24416 to SW24431	ID102		Same as above.
SW24432 to SW24447	ID103		Same as above.
SW24448 to SW24463	ID104		Same as above.
SW24464 to SW24479	ID105		Same as above.
SW24480 to SW24495	ID106		Same as above.
SW24496 to SW24511	ID107		Same as above.
SW24512 to SW24527	ID108		Same as above.
SW24528 to SW24543	ID109		Same as above.
SW24544 to SW24559	ID110		Same as above.

Continued on next page.

Continued from previous page.

Register Address	Remarks	
SW24560 to SW24575	ID111	Same as above.
SW24576 to SW24591	ID112	Same as above.
SW24592 to SW24607	ID113	Same as above.
SW24608 to SW24623	ID114	Same as above.
SW24624 to SW24639	ID115	Same as above.
SW24640 to SW24655	ID116	Same as above.
SW24656 to SW24671	ID117	Same as above.
SW24672 to SW24687	ID118	Same as above.
SW24688 to SW24703	ID119	Same as above.
SW24704 to SW24719	ID120	Same as above.

◆ Automatic Reception Status for Ethernet Communications

This section describes the data on the execution status of automatic reception (message functions).

■ System Configuration

System registers for data storage of the execution status of the automatic reception (message function) vary with the circuit number and CH number.

Name	Circuit Number 1	Circuit Number 2	Circuit Number 3	Circuit Number 4	Circuit Number 5	Circuit Number 6	Circuit Number 7	Circuit Number 8
Common Status	SW25000 to SW25003	SW25084 to SW25087	SW25168 to SW25171	SW25252 to SW25255	SW25336 to SW25339	SW25420 to SW25423	SW25504 to SW25507	SW25588 to SW25591
CH1 Status	SW25004 to SW25011	SW25088 to SW25095	SW25172 to SW25179	SW25256 to SW25263	SW25340 to SW25347	SW25424 to SW25431	SW25508 to SW25515	SW25592 to SW25599
CH2 Status	SW25012 to SW25019	SW25096 to SW25103	SW25180 to SW25187	SW25264 to SW25271	SW25348 to SW25355	SW25432 to SW25439	SW25516 to SW25523	SW25600 to SW25607
CH3 Status	SW25020 to SW25027	SW25104 to SW25111	SW25188 to SW25195	SW25272 to SW25279	SW25356 to SW25363	SW25440 to SW25447	SW25524 to SW25531	SW25608 to SW25615
CH4 Status	SW25028 to SW25035	SW25112 to SW25119	SW25196 to SW25203	SW25280 to SW25287	SW25364 to SW25371	SW25448 to SW25455	SW25532 to SW25539	SW25616 to SW25623
CH5 Status	SW25036 to SW25043	SW25120 to SW25127	SW25204 to SW25211	SW25288 to SW25295	SW25372 to SW25379	SW25456 to SW25463	SW25540 to SW25547	SW25624 to SW25631
CH6 Status	SW25044 to SW25051	SW25128 to SW25135	SW25212 to SW25219	SW25296 to SW25303	SW25380 to SW25387	SW25464 to SW25471	SW25548 to SW25555	SW25632 to SW25639
CH7 Status	SW25052 to SW25059	SW25136 to SW25143	SW25220 to SW25227	SW25304 to SW25311	SW25388 to SW25395	SW25472 to SW25479	SW25556 to SW25563	SW25640 to SW25647
CH8 Status	SW25060 to SW25067	SW25144 to SW25151	SW25228 to SW25235	SW25312 to SW25319	SW25396 to SW25403	SW25480 to SW25487	SW25564 to SW25571	SW25648 to SW25655
CH9 Status	SW25068 to SW25075	SW25152 to SW25159	SW25236 to SW25243	SW25320 to SW25327	SW25404 to SW25411	SW25488 to SW25495	SW25572 to SW25579	SW25656 to SW25663
CH10 Status	SW25076 to SW25083	SW25160 to SW25167	SW25244 to SW25251	SW25328 to SW25335	SW25412 to SW25419	SW25496 to SW25503	SW25580 to SW25587	SW25664 to SW25671

Information Refer to the following sections for automatic reception status in detail.

 **Automatic Reception Status Detail** on page 4-54

■ Automatic Reception Status Detail

• Common Status Detail

Register Address	Description
SW□□□□□ + 0	Rack Number
SW□□□□□ + 1	Unit Number
SW□□□□□ + 2	Slot Number
SW□□□□□ + 3	Subslot Number

- CH□ Status Detail



Register Address	Description	
SW□□□□□ + 0	Transmission Status	0: Unused connection 1: IDLE (Standby mode for executing message functions) 2: WAIT (Waiting to establish a connection) 3: CONNECT (Ready to send and receive data)
SW□□□□□ + 1	Latest Error Status	0: No error (Normal) 1: Socket creation error (System error) 2: Local port number error (Local port number setting error (The same address is bound during disconnection of the TCP connection.)) 3: Changing socket attribute error (System error (for TCP)) 4: Connection Error (M-SND) (Connection error (The connection was rejected by the remote station when establishing a connection with an unpassive open for TCP.)) 5: Connection error (M-RCV) (Connection error (with a passive open for TCP)) 6: System error 7: TCP data send error (Data sending error (The remote station does not exist or has not started when using TCP.)) 8: UDP data send error (Data sending error (for UDP)) 9: TCP data receive error (Data reception error (The MP3000 received a request to disconnect from the remote station for TCP.)) 10: UDP data receive error (Data reception error (for UDP)) 11: Changing socket option error (System error) 12: Data Conversion Error
SW□□□□□ + 2	Transmission Pulse Counter	
SW□□□□□ + 3	Reception Pulse Counter	
SW□□□□□ + 4	Error Counter	
SW□□□□□ + 5 to SW□□□□□ + 7	Reserved for system.	

◆ Maintenance Monitor Information

This section describes maintenance data of the Σ -7-series SERVOPACK connected through MECHATROLINK communications.

■ System Configuration

System registers for data storage of maintenance monitor information vary with the group and axis.

- Information**
 - Area of system register: 4 words from the first register
 - Groups and axes must be set in the MPE720 in advance. Refer to the following section for details.
 -  3.2.10 Maintenance Monitoring on page 3-102
 - Refer to the following section for details on maintenance monitor information.
 -  ■ Maintenance Monitor Information Detail on page 4-59

		Group 1	Group 2	Group 3	Group 4	Group 5	Group 6	Group 7	Group 8
Monitor Parameter Information		SW27600	SW27668	SW27736	SW27804	SW27872	SW27940	SW28008	SW28076
Axis Monitor Information	Selected Axis 1	SW27604	SW27672	SW27740	SW27808	SW27876	SW27944	SW28012	SW28080
	Selected Axis 2	SW27608	SW27676	SW27744	SW27812	SW27880	SW27948	SW28016	SW28084
	Selected Axis 3	SW27612	SW27680	SW27748	SW27816	SW27884	SW27952	SW28020	SW28088
	Selected Axis 4	SW27616	SW27684	SW27752	SW27820	SW27888	SW27956	SW28024	SW28092
	Selected Axis 5	SW27620	SW27688	SW27756	SW27824	SW27892	SW27960	SW28028	SW28096
	Selected Axis 6	SW27624	SW27692	SW27760	SW27828	SW27896	SW27964	SW28032	SW28100
	Selected Axis 7	SW27628	SW27696	SW27764	SW27832	SW27900	SW27968	SW28036	SW28104
	Selected Axis 8	SW27632	SW27700	SW27768	SW27836	SW27904	SW27972	SW28040	SW28108
	Selected Axis 9	SW27636	SW27704	SW27772	SW27840	SW27908	SW27976	SW28044	SW28112
	Selected Axis 10	SW27640	SW27708	SW27776	SW27844	SW27912	SW27980	SW28048	SW28116
	Selected Axis 11	SW27644	SW27712	SW27780	SW27848	SW27916	SW27984	SW28052	SW28120
	Selected Axis 12	SW27648	SW27716	SW27784	SW27852	SW27920	SW27988	SW28056	SW28124
	Selected Axis 13	SW27652	SW27720	SW27788	SW27856	SW27924	SW27992	SW28060	SW28128
	Selected Axis 14	SW27656	SW27724	SW27792	SW27860	SW27928	SW27996	SW28064	SW28132
	Selected Axis 15	SW27660	SW27728	SW27796	SW27864	SW27932	SW28000	SW28068	SW28136
	Selected Axis 16	SW27664	SW27732	SW27800	SW27868	SW27936	SW28004	SW28072	SW28140

		Group 9	Group 10	Group 11	Group 12	Group 13	Group 14	Group 15	Group 16
Monitor Parameter Information		SW28144	SW28212	SW28280	SW28348	SW28416	SW28484	SW28552	SW28620
Axis Monitor Information	Selected Axis 1	SW28148	SW28216	SW28284	SW28352	SW28420	SW28488	SW28556	SW28624
	Selected Axis 2	SW28152	SW28220	SW28288	SW28356	SW28424	SW28492	SW28560	SW28628
	Selected Axis 3	SW28156	SW28224	SW28292	SW28360	SW28428	SW28496	SW28564	SW28632
	Selected Axis 4	SW28160	SW28228	SW28296	SW28364	SW28432	SW28500	SW28568	SW28636
	Selected Axis 5	SW28164	SW28232	SW28300	SW28368	SW28436	SW28504	SW28572	SW28640
	Selected Axis 6	SW28168	SW28236	SW28304	SW28372	SW28440	SW28508	SW28576	SW28644
	Selected Axis 7	SW28172	SW28240	SW28308	SW28376	SW28444	SW28512	SW28580	SW28648
	Selected Axis 8	SW28176	SW28244	SW28312	SW28380	SW28448	SW28516	SW28584	SW28652
	Selected Axis 9	SW28180	SW28248	SW28316	SW28384	SW28452	SW28520	SW28588	SW28656
	Selected Axis 10	SW28184	SW28252	SW28320	SW28388	SW28456	SW28524	SW28592	SW28660
	Selected Axis 11	SW28188	SW28256	SW28324	SW28392	SW28460	SW28528	SW28596	SW28664
	Selected Axis 12	SW28192	SW28260	SW28328	SW28396	SW28464	SW28532	SW28600	SW28668
	Selected Axis 13	SW28196	SW28264	SW28332	SW28400	SW28468	SW28536	SW28604	SW28672
	Selected Axis 14	SW28200	SW28268	SW28336	SW28404	SW28472	SW28540	SW28608	SW28676
	Selected Axis 15	SW28204	SW28272	SW28340	SW28408	SW28476	SW28544	SW28612	SW28680
	Selected Axis 16	SW28208	SW28276	SW28344	SW28412	SW28480	SW28548	SW28616	SW28684

4.2 CPU Module Specifications

4.2.7 System Register Specifications

		Group 17	Group 18	Group 19	Group 20	Group 21	Group 22	Group 23	Group 24
Monitor Parameter Information		SW28688	SW28756	SW28824	SW28892	SW28960	SW29028	SW29096	SW29164
Axis Monitor Information	Selected Axis 1	SW28692	SW28760	SW28828	SW28896	SW28964	SW29032	SW29100	SW29168
	Selected Axis 2	SW28696	SW28764	SW28832	SW28900	SW28968	SW29036	SW29104	SW29172
	Selected Axis 3	SW28700	SW28768	SW28836	SW28904	SW28972	SW29040	SW29108	SW29176
	Selected Axis 4	SW28704	SW28772	SW28840	SW28908	SW28976	SW29044	SW29112	SW29180
	Selected Axis 5	SW28708	SW28776	SW28844	SW28912	SW28980	SW29048	SW29116	SW29184
	Selected Axis 6	SW28712	SW28780	SW28848	SW28916	SW28984	SW29052	SW29120	SW29188
	Selected Axis 7	SW28716	SW28784	SW28852	SW28920	SW28988	SW29056	SW29124	SW29192
	Selected Axis 8	SW28720	SW28788	SW28856	SW28924	SW28992	SW29060	SW29128	SW29196
	Selected Axis 9	SW28724	SW28792	SW28860	SW28928	SW28996	SW29064	SW29132	SW29200
	Selected Axis 10	SW28728	SW28796	SW28864	SW28932	SW29000	SW29068	SW29136	SW29204
	Selected Axis 11	SW28732	SW28800	SW28868	SW28936	SW29004	SW29072	SW29140	SW29208
	Selected Axis 12	SW28736	SW28804	SW28872	SW28940	SW29008	SW29076	SW29144	SW29212
	Selected Axis 13	SW28740	SW28808	SW28876	SW28944	SW29012	SW29080	SW29148	SW29216
	Selected Axis 14	SW28744	SW28812	SW28880	SW28948	SW29016	SW29084	SW29152	SW29220
	Selected Axis 15	SW28748	SW28816	SW28884	SW28952	SW29020	SW29088	SW29156	SW29224
	Selected Axis 16	SW28752	SW28820	SW28888	SW28956	SW29024	SW29092	SW29160	SW29228

		Group 25	Group 26	Group 27	Group 28	Group 29	Group 30	Group 31	Group 32
Monitor Parameter Information		SW29232	SW29300	SW29368	SW29436	SW29504	SW29572	SW29640	SW29708
Axis Monitor Information	Selected Axis 1	SW29236	SW29304	SW29372	SW29440	SW29508	SW29576	SW29644	SW29712
	Selected Axis 2	SW29240	SW29308	SW29376	SW29444	SW29512	SW29580	SW29648	SW29716
	Selected Axis 3	SW29244	SW29312	SW29380	SW29448	SW29516	SW29584	SW29652	SW29720
	Selected Axis 4	SW29248	SW29316	SW29384	SW29452	SW29520	SW29588	SW29656	SW29724
	Selected Axis 5	SW29252	SW29320	SW29388	SW29456	SW29524	SW29592	SW29660	SW29728
	Selected Axis 6	SW29256	SW29324	SW29392	SW29460	SW29528	SW29596	SW29664	SW29732
	Selected Axis 7	SW29260	SW29328	SW29396	SW29464	SW29532	SW29600	SW29668	SW29736
	Selected Axis 8	SW29264	SW29332	SW29400	SW29468	SW29536	SW29604	SW29672	SW29740
	Selected Axis 9	SW29268	SW29336	SW29404	SW29472	SW29540	SW29608	SW29676	SW29744
	Selected Axis 10	SW29272	SW29340	SW29408	SW29476	SW29544	SW29612	SW29680	SW29748
	Selected Axis 11	SW29276	SW29344	SW29412	SW29480	SW29548	SW29616	SW29684	SW29752
	Selected Axis 12	SW29280	SW29348	SW29416	SW29484	SW29552	SW29620	SW29688	SW29756
	Selected Axis 13	SW29284	SW29352	SW29420	SW29488	SW29556	SW29624	SW29692	SW29760
	Selected Axis 14	SW29288	SW29356	SW29424	SW29492	SW29560	SW29628	SW29696	SW29764
	Selected Axis 15	SW29292	SW29360	SW29428	SW29496	SW29564	SW29632	SW29700	SW29768
	Selected Axis 16	SW29296	SW29364	SW29432	SW29500	SW29568	SW29636	SW29704	SW29772

■ Maintenance Monitor Information Detail

• Monitor Parameter Information Detail

Register Address	Description	
SL□□□□□ + 0	Monitor Parameter Type	
SW□□□□□ + 2	Monitor Size	0001 hex: Word 0002 hex: Long word
SW□□□□□ + 3	Reserved for system.	

• Axis Monitor Information: Selected Axis□

Register Address	Description	
SW□□□□□ + 0	Circuit Number	
SW□□□□□ + 1	Axis Number	
SL□□□□□ + 2	Monitor Value	System registers for data storage vary with the monitor size. <ul style="list-style-type: none"> Word Monitor Size <ul style="list-style-type: none"> SW□□□□□ + 2: Monitor Value SW□□□□□ + 3: Reserved for system. (Always 0) Long Word Monitor Size <ul style="list-style-type: none"> SL□□□□□ + 2: Monitor Value

4.3 Base Unit Specifications

The specifications of the Base Units are listed in the following table.

Item	Specification				
	1 slot	3 slots	8 Slots	8 Slots	
Model	JEPMC-BU3304-E	JEPMC-BU3303-E	JEPMC-BU3302-E	JEPMC-BU3301-E	
Abbreviation	MBU-304	MBU-303	MBU-302	MBU-301	
Number of Slots	1	3	8	8	
Mountable Modules	MP2000-series Optional Modules				
Power Supply Section	Input Voltage	24 VDC		100/200 VAC	
	Allowable Input Voltage Range	19.2 to 28.8 VDC		85 to 132 VAC or 170 to 276 VAC	
	Allowable Frequency Range	-		47 to 63 Hz	
	Input Current	1.0 A max. (at rated input/output)	1.7 A max. (at rated input/output)	3.1 A max. (at rated input/output)	1.2 A or 0.8 A max. (at rated input/output)
	Inrush Current	40 A, 10 ms max.			20 A, 10 ms max. (fully discharged, 132-VAC input, rated output)
					50 A, 10 ms max. (fully discharged, 276-VAC input, rated output)
	Allowable Power Loss Time	1 ms		20 ms	
	Rated Voltage	5.15 V			
	Rated Current	2.5 A	4.5 A	9.0 A	9.0 A
	Output Current Range	0 to 2.5 A	0 to 4.5 A	0.3 to 9.0 A	0.3 to 9.0 A
Rated Voltage Accuracy	5.15 V ±2% max. (5.05 to 5.25 V)				
Battery	You can mount a memory backup Battery.				
RLY OUT	A NO relay output that is linked to the CPU Module status				
	<ul style="list-style-type: none"> • Normal operation: Circuit closed. • Error: Circuit open. 				
	Contact Ratings				
	Input Voltage	Current Capacity			
	24 VDC	0.5 A (resistive load) 0.25 A (inductive load)			
	125 VAC	0.4 A (resistive load) 0.2 A (inductive load)			
Indicators	POWER				
Connectors	<ul style="list-style-type: none"> • POWER: Power supply connector • RLY OUT: Relay contact connector 				

External Dimensions



This section provides external diagrams and dimensions for the MP3300.

5.1	CPU Module	5-2
5.2	Base Units	5-3

5.1 CPU Module

CPU-301

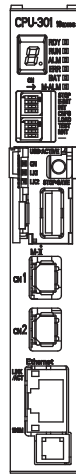
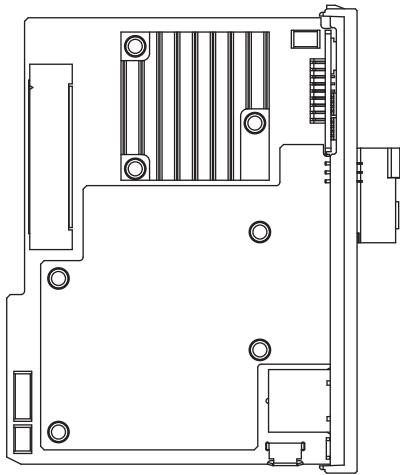
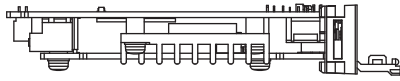

Approx. weight: 0.2 kg

CPU-302

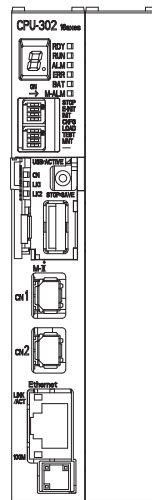
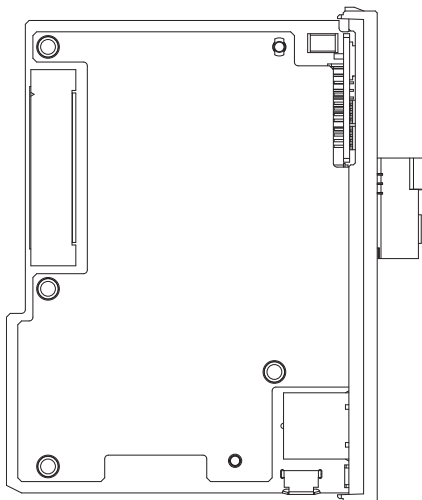
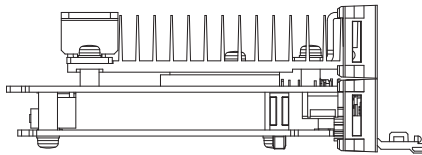

Approx. weight: 0.3 kg

5.2 Base Units

One-slot Base Unit

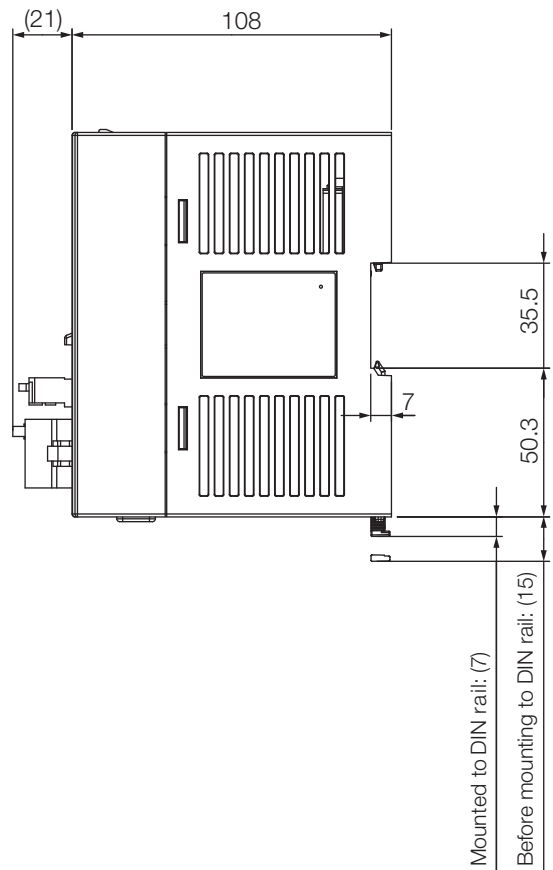
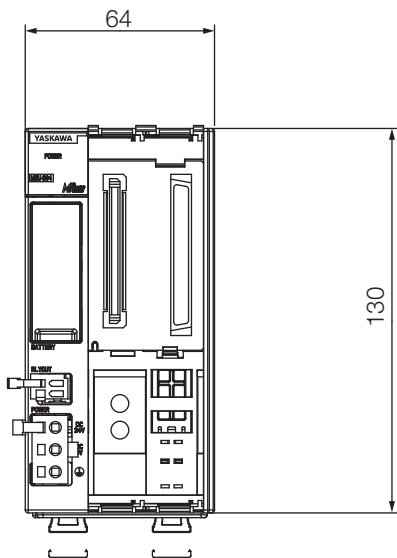
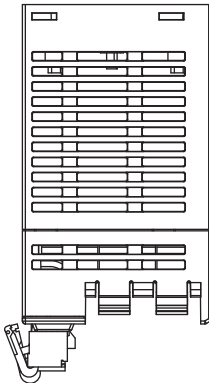

Unit: mm
 Approx. weight: 0.4 kg

Three-slot Base Unit

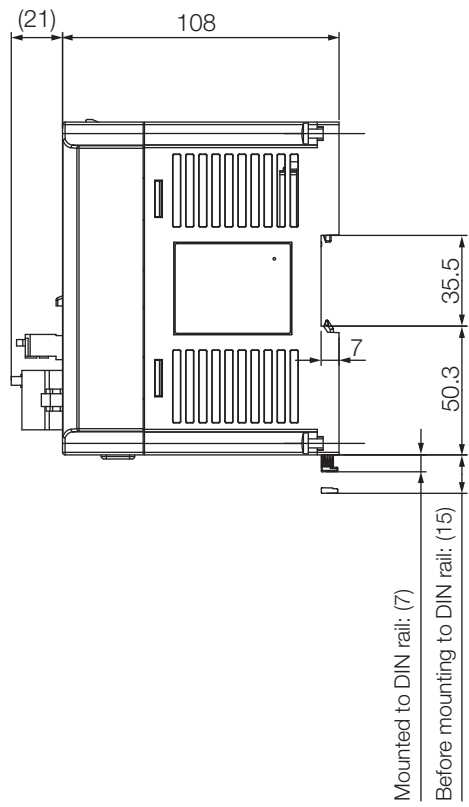
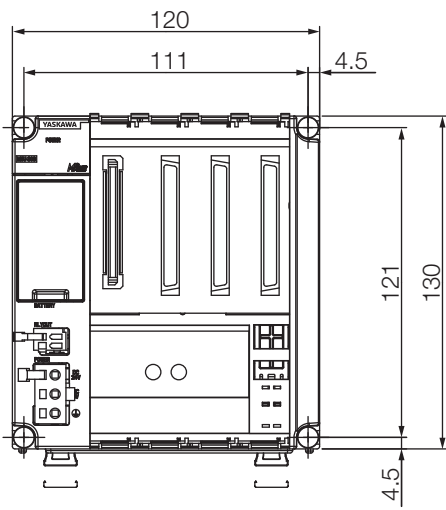
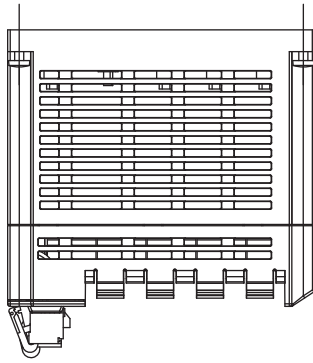

Unit: mm
 Approx. weight: 0.5 kg

Eight-slot Base Unit

■ MBU-301

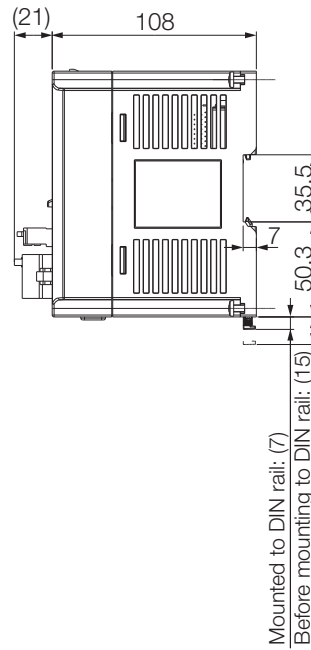
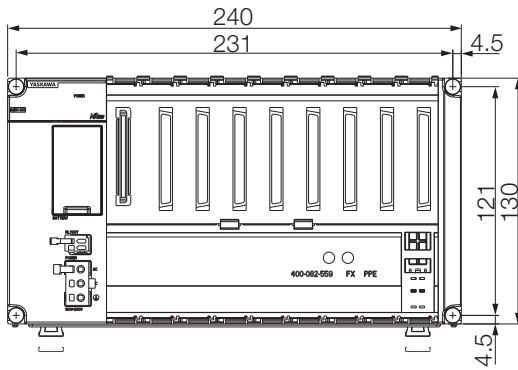
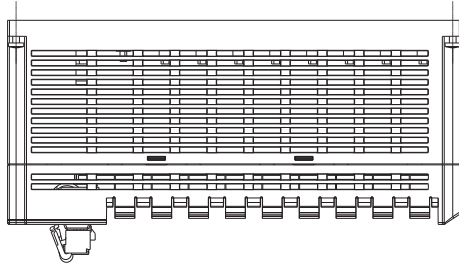

Mounted to DIN rail: (7)
 Before mounting to DIN rail: (15)

Unit: mm
 Approx. weight: 0.7 kg

■ MBU-302

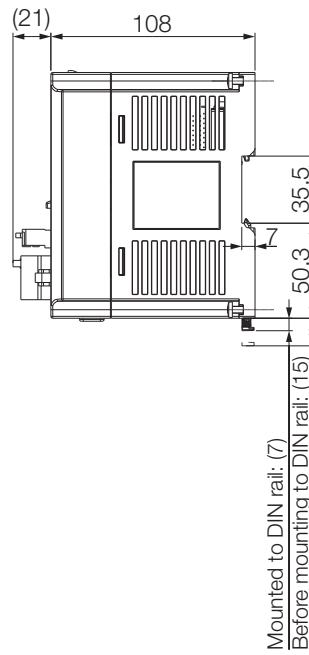
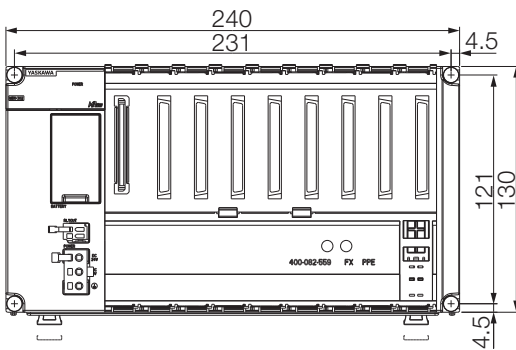
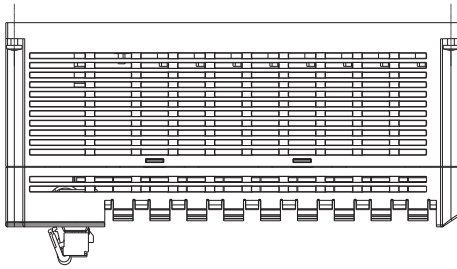

Unit: mm
Approx. weight: 0.7 kg

Index

System Registers

Alarm History Information	4-48
Automatic Reception Status for Ethernet Communications	4-54
CPU Module Information	4-27
CPU System Status	4-18
Data Logging Execution Status	4-51
Detailed User Operation Error Status	4-23
Expansion System Service Execution Status	4-48
FTP Client Status and Control Information	4-52
Interrupt Status	4-26
Maintenance Monitor Information	4-56
Message Relaying Status	4-26
Motion Program Execution Information	4-36
MPU-01 Module Status	4-33
Optional Module Information	4-29
Overall Configuration	4-11
Product Information	4-50
PROFINET Controller (266IF-01) IOPS Status Information	4-35
Security Status	4-25
System Error Status	4-19
System I/O Error Status	4-24
System Service Execution Status	4-23
System Service Registers	4-14
USB-related System Status	4-25

A

address	3-22
Alarm Reset Request	3-10
array registers	3-27

B

background processing	3-28
Base Units	2-11
appearance	2-11
specifications	4-60
Battery	1-6
bit	3-21

C

calendar	3-101
child drawings	3-3
circuit numbers	1-10
precautions when setting the circuit numbers	1-10
Communications Function Module	3-45
specifications	4-8
Communications Modules	1-8
controlling the execution of drawings	3-28

CPU Module	2-2
appearance	2-2
basic functionality	3-2
communications specifications	4-8
Function Modules	3-35
performance specifications	4-5
CPU-301	4-4
CPU-302	4-4

D

data logging	3-66
definition information updated by self configuration	3-43
DIP switches	2-7
double-length integer	3-21
double-precision real number	3-22
DWG.A	3-4
DWG.H	3-4
DWG.I	3-4
DWG.L	3-4

E

expansion interface module cables	1-7
Expansion Rack	1-2
external dimensions	
Base Unit	5-3
Power Supply Unit	5-2

F

file transfer	3-91
FTP client	3-97
FTP server	3-91
functions	3-5
standard system functions	3-5
user functions	3-5

G

global registers	3-17, 3-18
grandchild drawings	3-3

H

high-speed (H) scan	3-29
---------------------	------

I

I/O Modules	1-9
index registers	3-25
integer	3-21
Interpolation Override Setting	3-11

L

ladder programs	3-2
local registers	3-17, 3-19
low-speed (L) scan	3-31

M

maintenance monitoring- - - - -3-102
 M-EXECUTOR - - - - - 3-53
 detail settings - - - - - 3-57
 execution scheduling - - - - - 3-64
 initialization - - - - - 3-54
 registering program execution - - - - - 3-63
 specifications - - - - - 4-10
 Module Configuration Tab Page- - - - - 3-57
 Motion Control Function Modules- - - - - 3-47
 specifications - - - - - 4-9
 Motion Modules - - - - - 1-8
 motion programs - - - - - 3-6
 execution- - - - - 3-6
 monitoring execution information - - - - - 3-14
 specifying motion programs - - - - - 3-8
 work registers - - - - - 3-9
 MP3300 - - - - - 1-2
 list - - - - - 1-7
 usage conditions - - - - - 4-2

O

operation error drawings - - - - - 3-3
 Optional Modules - - - - - 1-8

P

parent drawings - - - - - 3-3
 power connector - - - - - 2-12
 precautions when setting module configuration
 definitions- - - - - 1-10
 Program Single-block Mode Selection- - - - - 3-10
 Program Single-block Start Request - - - - - 3-10
 programs - - - - - 3-2
 types of programs - - - - - 3-2

Q

quadruple-length integer - - - - - 3-21

R

Racks - - - - - 1-2
 real number - - - - - 3-22
 registers - - - - - 3-17
 data types - - - - - 3-21
 register types - - - - - 3-18
 structure of register addresses - - - - - 3-18
 Request for Pause of Program - - - - - 3-10
 Request for Start of Continuous Program Operation- - - 3-10
 Request for Start of Program Operation- - - - - 3-10
 Request for Stop of Program - - - - - 3-10
 RLYOUT connector - - - - - 2-11

S

scans- - - - - 3-29
 types of scans - - - - - 3-29
 scheduling the execution of high-speed and
 low-speed scan process drawings - - - - - 3-28
 security - - - - - 3-101
 self configuration - - - - - 3-35
 specified Modules - - - - - 3-41
 using the DIP switch- - - - - 3-36
 using the MPE720 - - - - - 3-39
 sequence programs - - - - - 3-15
 execution- - - - - 3-15
 specifying sequence programs - - - - - 3-16
 work registers - - - - - 3-16
 setting the high-speed and low-speed times- - - - - 3-32
 Skip 1 Information - - - - - 3-11
 Skip 2 Information - - - - - 3-11
 system configuration - - - - - 1-5
 devices and components- - - - - 1-6
 System Work Number Setting - - - - - 3-11

U

USB memory- - - - - 3-87
 System Registers - - - - - 4-20

Revision History

The date of publication, revision number, and web revision number are given at the bottom right of the back cover. Refer to the following example.

MANUAL NO. SIEP C880725 21B <1>-0
 Published in Japan October 2014

┌─── Web revision number
 └─── Revision number
 └─── Date of publication

Date of Publication	Rev. No.	Web Rev. No.	Section	Revised Contents
December 2019	<4>	1	3.2.9	Revision: Partly revised.
			Back cover	Revision: Address
November 2018	<4>	0	All chapters	Revision: Partly revised.
			3.2.5	Addition: Information on storing logging data on the FTP server Newly added: Preparations if configuring logging settings from tools other than the MPE720
			3.2.9	Addition: μ s Calendar
			3.2.10	Addition: Setting items of maintenance monitoring
			Back cover	Revision: Address
September 2017	<3>	3	2.1.1	Revision: Figures in precautions when using a CPU-302 module
			3.1.1	Revision: Figure in execution processing of drawings
			3.1.4	Revision: Set values of the high-speed (H) scan times when the MP2000 optional module is used
			Back cover	Revision: Address
March 2017	<3>	2	3.2.6	Revision: Correction of terms used in the table about batch saving to USB memory (Change from "Registers to Load" to "Registers to Save".)
January 2017		1	3.2.7	Addition: Information on versions that support the use of the FTP server for the CPU Module and MPE720
December 2015	<3>	0	Back cover	Revision: Address
			All sections	Addition: Information related to Rack Expansion Interface Unit
June 2015	<2>	0	3.1.4	Revision: Setting range for communications cycle, 1.5 ms to 3 ms
			3.2	Addition: Information related to the alarm history
			Back cover	Revision: Address
			1.2	Revision: System configuration examples
			1.3	Addition: Expansion Interface Module Cables Revision: SERVOPACKs with MECHATROLINK-III Communications Model numbers of Battery with Special Connector, Front Cover for Unused Slot, and MPE720 version 7.
			1.3.1, 4.3, 5.2	Addition: Base Units (JEPMC-BU3302-E and JEPMC-BU3301-E)
			1.3.1, 2.1.1, 4.2.1, 5.1	Addition: CPU Modules (JAPMC-CP3302-1-E and JAPMC-CP3302-2-E)
			2.2.2	Addition: AC power supply connector
3.1.4	Addition: Example with high-speed scan time set to 0.125 ms			
3.2.10	Addition: Maintenance monitoring for Controller installation environment			
October 2014	<1>	0	Front cover, back cover	Revision: Format
			All chapters	Addition: CPU Module model: JAPMC-CP3301-2-E Motion Control Function Module models: SVC32, SVR32
			3.2.10	Addition: Maintenance monitoring
April 2014	-	-	-	Revision: Address
April 2014	-	-	-	First edition

Machine Controller MP3000 Series

MP3300

Product Manual

IRUMA BUSINESS CENTER (SOLUTION CENTER)

480, Kamifujisawa, Iruma, Saitama, 358-8555, Japan
Phone: +81-4-2962-5151 Fax: +81-4-2962-6138
www.yaskawa.co.jp

YASKAWA AMERICA, INC.

2121, Norman Drive South, Waukegan, IL 60085, U.S.A.
Phone: +1-800-YASKAWA (927-5292) or +1-847-887-7000 Fax: +1-847-887-7310
www.yaskawa.com

YASKAWA ELÉTRICO DO BRASIL LTDA.

777, Avenida Piraporinha, Diadema, São Paulo, 09950-000, Brasil
Phone: +55-11-3585-1100 Fax: +55-11-3585-1187
www.yaskawa.com.br

YASKAWA EUROPE GmbH

Hauptstraße 185, 65760 Eschborn, Germany
Phone: +49-6196-569-300 Fax: +49-6196-569-398
www.yaskawa.eu.com E-mail: info@yaskawa.eu.com

YASKAWA ELECTRIC KOREA CORPORATION

35F, Three IFC, 10 Gukjegeumyung-ro, Yeongdeungpo-gu, Seoul, 07326, Korea
Phone: +82-2-784-7844 Fax: +82-2-784-8495
www.yaskawa.co.kr

YASKAWA ASIA PACIFIC PTE. LTD.

30A, Kallang Place, #06-01, 339213, Singapore
Phone: +65-6282-3003 Fax: +65-6289-3003
www.yaskawa.com.sg

YASKAWA ELECTRIC (THAILAND) CO., LTD.

59, 1F-5F, Flourish Building, Soi Ratchadapisek 18, Ratchadapisek Road, Huaykwang, Bangkok, 10310, Thailand
Phone: +66-2-017-0099 Fax: +66-2-017-0799
www.yaskawa.co.th

YASKAWA ELECTRIC (CHINA) CO., LTD.

22F, Link Square 1, No.222, Hubin Road, Shanghai, 200021, China
Phone: +86-21-5385-2200 Fax: +86-21-5385-3299
www.yaskawa.com.cn

YASKAWA ELECTRIC (CHINA) CO., LTD. BEIJING OFFICE

Room 1011, Tower W3 Oriental Plaza, No.1, East Chang An Avenue,
Dong Cheng District, Beijing, 100738, China
Phone: +86-10-8518-4086 Fax: +86-10-8518-4082

YASKAWA ELECTRIC TAIWAN CORPORATION

12F, No. 207, Section 3, Beishin Road, Shindian District, New Taipei City 23143, Taiwan
Phone: +886-2-8913-1333 Fax: +886-2-8913-1513 or +886-2-8913-1519
www.yaskawa.com.tw

YASKAWA

YASKAWA ELECTRIC CORPORATION

In the event that the end user of this product is to be the military and said product is to be employed in any weapons systems or the manufacture thereof, the export will fall under the relevant regulations as stipulated in the Foreign Exchange and Foreign Trade Regulations. Therefore, be sure to follow all procedures and submit all relevant documentation according to any and all rules, regulations and laws that may apply.

Specifications are subject to change without notice for ongoing product modifications and improvements.

© 2014 YASKAWA ELECTRIC CORPORATION

MANUAL NO. SIEP C880725 21E <4>-1

Published in Japan December 2019

19-10-16

Original instructions