

AC Servo Drives

Σ -V-SD Series

USER'S MANUAL

For Command Profile

Rotational Motor

EtherCAT (CoE) Communications Reference

UAK□J-□□C□□ Spindle motor
SGMGV-□□□8□□□ Servomotor
CACP-JU□□□3□ Power regeneration converter
CACR-JU□□□□C□ SERVOPACK

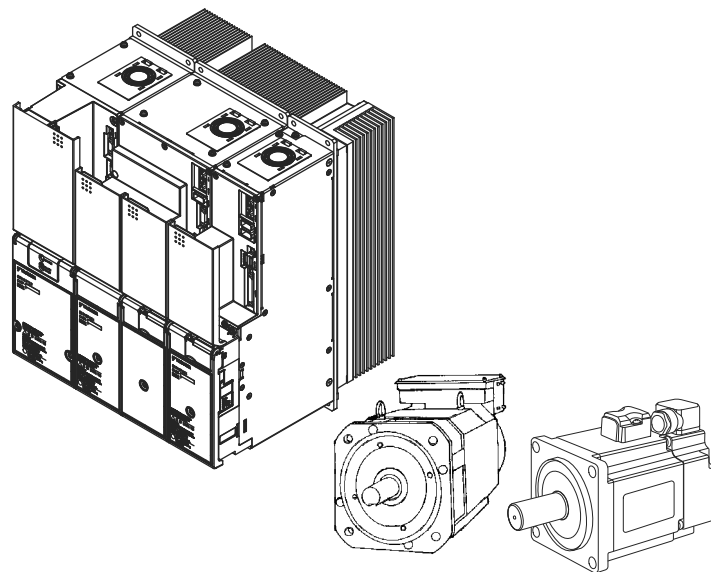

Specifications	1
EtherCAT Communications	2
CiA402 Drive Profile	3
Object Dictionary	4
Appendix	5

Copyright © 2013 YASKAWA ELECTRIC CORPORATION

All rights reserved. No part of this publication may be reproduced, stored in a retrieval system, or transmitted, in any form, or by any means, mechanical, electronic, photocopying, recording, or otherwise, without the prior written permission of Yaskawa. No patent liability is assumed with respect to the use of the information contained herein. Moreover, because Yaskawa is constantly striving to improve its high-quality products, the information contained in this manual is subject to change without notice. Every precaution has been taken in the preparation of this manual. Nevertheless, Yaskawa assumes no responsibility for errors or omissions. Neither is any liability assumed for damages resulting from the use of the information contained in this publication.

About this Manual

This manual describes the command profiles for EtherCAT (CoE) communications references that are used in Σ -V-SD SERVOPACK when used with a rotational motor.

Keep this manual in a location where it can be accessed for reference whenever required. Manuals outlined on the following page must also be used as required by the application.

■ Description of Technical Terms

The following table shows the meanings of terms used in this manual.

Term	Meaning
Spindle Motor	Σ -V-SD Series UAKAJ and UAKBJ motor
Servomotor	Σ -V-SD Series SGMGV servomotor
Power Regeneration Converter	Σ -V-SD Series CACP-JU converter
SERVOPACK	Σ -V-SD Series CACR-JU servo amplifier
SERVOPACK for One Axis	A SERVOPACK that can control one motor
SERVOPACK for Two Axes	A SERVOPACK that can control two motors
Σ -V-SD Driver	A power regeneration converter and a SERVOPACK
Servo Drive	A set including a servomotor (or a spindle motor) and a Σ -V-SD driver
Servo ON	The power to the motor ON
Servo OFF	The power to the motor OFF
Base Block (BB)	The power supply to motor is turned OFF by shutting off the base current to the power transistor in the current amplifier.
EtherCAT (CoE) Module	A device in a Σ -V-SD SERVOPACK called a function module that manages and controls the references for EtherCAT (CoE) communications when the SERVOPACK is used with a rotational motor.

■ IMPORTANT Explanations

The following icon is displayed for explanations requiring special attention.

 IMPORTANT	<ul style="list-style-type: none">• Indicates important information that should be memorized, as well as precautions, such as alarm displays, that do not involve potential damage to equipment.
--	--

■ Notation Used in this Manual

• Notation for Reverse Signals

The names of reverse signals (i.e., ones that are valid when low) are written with a forward slash (/) before the signal name.

Notation Example

\overline{BK} = /BK

• Notation for Parameters

The notation depends on whether the parameter requires a value setting (parameter for numeric settings) or requires the selection of a function (parameter for selecting functions).

• Parameters for Numeric Settings

Control methods for which the parameter applies.					
Speed : Speed control Position : Position control Torque : Torque control					
Pn406 (20A2h)	Emergency Stop Torque				
	Setting Range	Setting Unit	Factory Setting	When Enabled	Classification
	0 to 800	1%	800	After change	Setup

Parameter number (Index Number) indicates the setting range for the parameter.

Indicates the minimum setting unit for the parameter.

Indicates the parameter setting before shipment.

Indicates when a change to the parameter will be effective.

Indicates the parameter classification.

• Parameters for Selecting Functions

Parameter (Index Number)	Meaning	When Enabled	Classification
Pn002 (2002h)	n.□0□□ [Factory setting]	After restart	Setup
	n.□1□□		

Parameter number (Index Number)

The notation "n.□□□□" indicates a parameter for selecting functions. Each □ corresponds to the setting value of that digit. The notation shown here means that the third digit is 1.

This section explains the selected function.

• Notation for Index Numbers of EtherCAT (CoE) Commands

When an EtherCAT (CoE) command consists of an index number and a subindex number, the index and sub-index numbers are separated by a colon.

Notation Example

2030h:1

↑ Subindex number

↑ Index number

• Notation for Index Numbers of Servo Parameters

The index numbers for a SERVOPACK for one axis and axis 1 of a SERVOPACK for two axes are given for the index numbers of the servo parameters. The index numbers for axis 2 of a SERVOPACK for two axes can be calculated by adding 400 hex to the index numbers for axis 1.

Example:

Parameter number: Pn100

= Index number for axis 1: 2040h

↓ Add 400 hex to calculate the index number for axis 2.

= Index number for axis 2: 2440h

■ Manuals Related to the Σ -V-SD Series

Refer to the following manuals as required.

Name	Selecting Models and Peripheral Devices	Ratings and Specifications	System Design	Panels and Wiring	Trial Operation	Trial Operation and Servo Adjustment	Maintenance and Inspection
Σ -V-SD Series User's Manual Design and Maintenance Rotational Motor/ EtherCAT (CoE) Communications Reference (SIEP S800000 94)	✓	✓		✓	✓	✓	✓
Σ -V-SD Series User's Manual For Command Profile Rotational Motor/ EtherCAT (CoE) Communications Reference (this manual)			✓		✓	✓	
Σ -V-SD Series Safety Precautions (TOBP C710829 04)	✓			✓			✓
AC SERVOMOTOR Safety Precautions (TOBP C2300200 00)				✓			✓
Σ -V-SD Series Safety Precautions Base Mounting Unit (TOMP C710829 08)	✓						✓

■ Safety Information

The following conventions are used to indicate precautions in this manual. Failure to heed precautions provided in this manual can result in serious or possibly even fatal injury or damage to the products or to related equipment and systems.



Indicates precautions that, if not heeded, could possibly result in loss of life or serious injury.



Indicates precautions that, if not heeded, could result in relatively serious or minor injury, damage to the product, or faulty operation. In some situations, the precautions indicated could have serious consequences if not heeded.



Indicates prohibited actions that must not be performed. For example, this symbol would be used to indicate that fire is prohibited as follows:



Indicates compulsory actions that must be performed. For example, this symbol would be used to indicate that grounding is compulsory as follows:





Safety Precautions

This section describes important precautions that must be followed during storage, transportation, installation, wiring, operation, maintenance, inspection, and disposal. Be sure to always observe these precautions thoroughly.

WARNING

- Never touch the rotating parts of the motor during operation or adjustments.
Failure to observe this warning may result in injury.
- Before starting operation with a machine connected, make sure that an emergency stop can be applied at any time.
Failure to observe this warning may result in injury or damage to the product.
- Never touch the inside of the power regeneration converters and SERVOPACKs.
Failure to observe this warning may result in electric shock.
- Do not remove the cover of power supply terminal while the power is ON.
Failure to observe this warning may result in electric shock.
- Do not touch terminals before the main-circuit capacitor has had time to discharge after the power has been turned OFF because high voltage may still remain in the power regeneration converter and SERVOPACK. For the details of discharge time of main-circuit capacitor, refer to 7.2.1 *Main Circuit in Σ -V-SD series User's Manual Design and Maintenance Rotational Motor EtherCAT (CoE) Communications Reference (manual no.: SIEP S800000 94)*.
Residual voltage may cause electric shock.
- Do not touch terminals while the charge indicator is lit.
Residual voltage may cause electric shock.
After the charge indicator goes out, check the voltage on the DC bus line (i.e., between the P and N terminals) with a voltage tester before you perform wiring or inspection work.
- Do not touch terminals before the main-circuit capacitor has had time to discharge after voltage resistance test. For the details of discharge time of main-circuit capacitor, refer to 7.2.1 *Main Circuit in Σ -V-SD series User's Manual Design and Maintenance Rotational Motor EtherCAT (CoE) Communications Reference (manual no.: SIEP S800000 94)*.
Residual voltage may cause electric shock.
- Make sure that trial operation was completed successfully before you make adjustments.
Failure to observe this warning may result in injury or damage to the product.
- Follow the procedures and instructions for the trial operation as noted in the applicable manual for that product.
Malfunctions that occur after the motor is connected to the equipment not only damage the equipment, but may also cause an accident resulting in death or injury.
- The output range of multi-turn data for Σ -V-SD driver absolute detection system differs from that for conventional systems (15-bit encoder and 12-bit encoder). Especially when "Infinite length positioning system" of Σ series is to be configured with Σ -V-SD series, be sure to make the system modification.
- When you set up the absolute encoder, the multiturn data will change to between minus two and plus two turns. This will cause the reference position of the machine to change. Adjust the reference position at the host controller to the correct position after you perform the setup.
If the machine is operated without aligning the position in the host controller, unintended operation may occur and may result in injuries or damage to the machine. Be careful when starting the machine to ensure that this does not occur.
- The multi-turn limit value must be changed only for special applications.
Changing it inappropriately or unintentionally can be dangerous.
- If the Multi-turn Limit Disagreement alarm occurs, check the setting of parameter Pn205 in the SERVOPACK to be sure that it is correct.
If the multi-turn limit value setting is implemented while an incorrect value is set in Pn205, an incorrect value will be set in the encoder. The alarm will disappear even if an incorrect value is set, but incorrect positions will be detected, resulting in a dangerous situation where the machine will move to unexpected positions.
- Do not remove the front cover, cables, connectors, or optional items on the foreside while the power is ON.
Failure to observe this warning may result in electric shock.
- Do not damage, press, exert excessive force or place heavy objects on the cables.
Failure to observe this warning may result in electric shock, stopping operation of the product, or fire.
- Do not modify the product.
Failure to observe this warning may result in injury, damage to the product, or fire.

WARNING

- Provide an appropriate braking device on the machine side to ensure safety. A holding brake for a servomotor with brake is not a braking device for ensuring safety.
Failure to observe this warning may result in injury.
- Do not come close to the machine immediately after resetting momentary power loss to avoid an unexpected restart. Take appropriate measures to ensure safety against an unexpected restart.
Failure to observe this warning may result in injury.
- Refer to the SigmaWin for Σ -V-SD (MT) Operation Manual before you make adjustments.
Failure to observe this warning may result in injury or damage to the product.
-  Connect the ground terminal to electrical codes (ground resistance: 100 Ω or less for a power regeneration converter and a SERVOPACK with a 200 V power supply. 10 Ω or less for a power regeneration converter and a SERVOPACK with a 400 V power supply).
Improper grounding may result in electric shock or fire.
-  Installation, disassembly, or repair must be performed only by authorized personnel.
Failure to observe this warning may result in electric shock or injury.
- The person who designs a system using the Hard Wire Base Block function must have full knowledge of the related safety standards and full understanding of the instructions in this manual.
Failure to observe this warning may result in injury or damage to the product.

■ Storage and Transportation

CAUTION

- Do not store or install the product in the following places.
 - Locations subject to direct sunlight.
 - Locations subject to temperatures outside the range specified in the storage/installation temperature conditions.
 - Locations subject to humidity outside the range specified in the storage/installation humidity conditions.
 - Locations subject to condensation as the result of extreme changes in temperature.
 - Locations subject to corrosive or flammable gases.
 - Locations subject to dust, salts, or iron dust.
 - Locations subject to exposure to water, oil, or chemicals.
 - Locations subject to shock or vibration.Failure to observe this caution may result in fire, electric shock, or damage to the product.
- Do not hold the motors by the cable, motor shaft, or encoder while transporting it.
Failure to observe this caution may result in injury or malfunction.
- Do not hold the power regeneration converters and SERVOPACKs by the front cover or terminal cover while moving them.
Failure to observe this caution may result in damage to the covers or in a greater possibility of the products being dropped and damaged.
- Do not place any load exceeding the limit specified on the packing box.
Failure to observe this caution may result in injury or malfunction.
- If disinfectants or insecticides must be used to treat packing materials such as wooden frames, pallets, or plywood, the packing materials must be treated before the product is packaged, and methods other than fumigation must be used.
Example: Heat treatment, where materials are kiln-dried to a core temperature of 56°C for 30 minutes or more.
If the electronic products, which include stand-alone products and products installed in machines, are packed with fumigated wooden materials, the electrical components may be greatly damaged by the gases or fumes resulting from the fumigation process. In particular, disinfectants containing halogen, which includes chlorine, fluorine, bromine, or iodine can contribute to the erosion of the capacitors.

■ Installation

CAUTION

- Never use the products in an environment subject to water, corrosive gases, inflammable gases, or combustibles.
Failure to observe this caution may result in electric shock or fire.
- Do not step on or place a heavy object on the product.
Failure to observe this caution may result in injury or malfunction.
- Do not cover the inlet or outlet ports and prevent any foreign objects from entering the product.
Failure to observe this caution may cause internal elements to deteriorate resulting in malfunction or fire.
- Be sure to install the product in the correct direction.
Failure to observe this caution may result in malfunction.
- Provide the specified clearances between the power regeneration converter and the inside surface of the control panel and between the SERVOPACK and the inside surface of the control panel, and keep both the converter and the SERVOPACK sufficiently separated from all other devices.
Failure to observe this caution may result in fire or malfunction.
- Do not apply any strong impact.
Failure to observe this caution may result in malfunction.
- Provide at least 100 mm between the machine and the side of the motor that is opposite from the load (i.e., the side where cooling air is exhausted) to ensure sufficient flow of cooling air to the cooling fan.
If there is not sufficient airflow, the motor temperature fault protective function may operate even at the rated load.
- Do not allow water, oil, or other liquids to come in direct contact with the motor. If there is a chance that water, oil, or other liquids may come into direct contact with the motor, install a protective cover.
If water, oil, or other liquids enter the motor, the resistance will be lowered and a ground fault may occur.
- Install the motor on a sturdy mounting bed, base, stand or other structure.
The weight of the motor and the dynamic load during operation are placed on the installation structure and may cause vibration if the structure is not sturdy enough.

■ Wiring

CAUTION

- Be sure to wire correctly and securely.
Failure to observe this caution may result in motor overrun, injury, or malfunction.
- Install the I/O signal cables and encoder cable at least 30 cm away from the motor's main circuit cable. Never place them in the same duct or bundle them together.
Placing these cables too close to each other may result in malfunction.
- The maximum wiring length is 3 m for I/O signal cables, 20 m for encoder cables or motor main circuit cables, and 10 m for control power supply cables (+24 V, 0 V).
- To extend the encoder cable past 20 m, always use an extension encoder cable.
- If the main circuit cable length of the servomotor exceeds 20 m, the voltage drop along the cable will increase greatly and the intermittent duty zone of the torque-motor speed characteristics will be reduced.
- Use twisted-pair shielded wires or multi-core twisted pair shielded wires for input/output signal cables and the encoder cables.
- When you connect the cables, do not touch with your bare hands the motor connector pins or the encoder connector pins that are provided with the motor.
Particularly the encoder may be damaged by static electricity.
- Take appropriate and sufficient countermeasures for each when installing systems in the following locations.
 - Locations subject to static electricity or other forms of noise.
 - Locations subject to strong electromagnetic fields and magnetic fields.
 - Locations subject to possible exposure to radioactivity.
 - Locations close to power supplies.Failure to observe this caution may result in damage to the product.
- Wiring or inspection must be performed by a technical expert.
- Do not connect a commercial power supply to the U, V, or W motor connection terminals.
Failure to observe this caution may result in injury or fire.

CAUTION

- Do not connect the motor directly to a commercial power supply.
The motor may be damaged. Connect the motor to the correct SERVOPACK.
- Securely connect the power supply terminal screws and motor connection terminal screws.
Failure to observe this caution may result in fire.
- Do not touch the power terminals before the main-circuit capacitor has had time to discharge because high voltage may still remain in the power regeneration converter and SERVOPACK. For the details of discharge time of main-circuit capacitor, refer to 7.2.1 Main Circuit in *Σ-V-SD series User's Manual Design and Maintenance Rotational Motor EtherCAT (CoE) Communications Reference (manual no.: SIEP S800000 94)*.
First make sure the charge indicator is turned OFF and that the DC-bus (symbol: P and N) voltage value is correct by using a tester or other device before wiring or starting an inspection.
- Observe the following precautions when wiring main circuit terminal blocks.
 - Do not turn the servo drive power ON until all wiring, including the main circuit terminal blocks has been completed.
 - If the main circuit terminal is the connector, remove the connector from the SERVOPACK prior to wiring.
 - Insert only one wire per insertion slot on the terminal block and the connector.
 - Make sure that the core wire is not electrically shorted to adjacent core wires.
- Always use the specified power supply voltage.
An incorrect voltage may result in fire.
- Make sure that the polarity is correct.
Incorrect polarity may cause ruptures or damage.
- Take appropriate measures to ensure that the input power supply is supplied within the specified voltage fluctuation range. Be particularly careful in places where the power supply is unstable.
An incorrect power supply may result in damage to the product.
- Install external breakers or other safety devices against short-circuiting in external wiring.
Failure to observe this caution may result in fire.
- For the control power supply, use a 24-VDC power supply with double insulation or reinforced insulation against primary. Make sure that the output holding time is 100 ms or more.
- Do not reverse the polarity of the battery when connecting it.
Failure to observe this caution may damage the battery, power regeneration converter, SERVOPACK, and motor or cause it to explode.
- Install the battery at the power regeneration converter.
It is dangerous to install batteries at encoder cable, because that sets up a loop circuit between the batteries.
- The motor does not provide overheating protection. If complying with NEC (National Electric Code) is necessary, implement overheating protection for the motor. However, overheating protection is not required if you use a SGMGV servomotor or UAKAJ spindle motor. (This is because continuous operation is possible within the ratings and SERVOPACK protection will function if the ratings are exceeded.)

■ Operation

CAUTION

- Always use the motor and SERVOPACK in one of the specified combinations.
Failure to observe this caution may result in fire or malfunction.
- Conduct trial operation on the motor alone with the motor shaft disconnected from machine to avoid any unexpected accidents.
Failure to observe this caution may result in injury.
- During trial operation, confirm that the holding brake works correctly. Furthermore, secure system safety against problems such as signal line disconnection.
- Before starting operation with a machine connected, change the settings to match the parameters of the machine.
Starting operation without matching the proper settings may cause the machine to run out of control or malfunction.
- Avoid frequently turning the power ON and OFF.
Since the Σ-V-SD driver have a capacitor in the power supply, a high charging current flows when power is turned ON. Frequently turning the power ON and OFF causes main power devices like capacitors and fuses in the power regeneration converter and the SERVOPACK to deteriorate more quickly, resulting in unexpected problems.

CAUTION

- Forced stop function with forward/reverse overtravel is not effective during JOG mode operation and zero point search using SigmaWin for Σ -V-SD (MT).
- Make sure that the motor constants for the spindle motors being used match the parameters of the SERVOPACKs before supplying power when driving spindle motors by using Σ -V-SD series SERVOPACK.
Failure to observe this caution may result in injury, fire, and damage to the product.
- When using the servomotor for a vertical axis, install the safety devices to prevent workpieces to fall off due to occurrence of alarm or overtravel. Set the servomotor so that it will stop in the zero clamp state at occurrence of overtravel.
Failure to observe this caution may cause workpieces to fall off due to overtravel.
- Do not touch the power regeneration converter and SERVOPACK heat sinks or servomotor while the power is ON or soon after the power is turned OFF.
Failure to observe this caution may result in burns due to high temperatures.
- Do not make any extreme adjustments or setting changes of parameters.
Failure to observe this caution may result in injury or damage to the product due to unstable operation.
- When an alarm occurs, remove the cause, clear the alarm after confirming safety, and then resume operation.
Failure to observe this caution may result in damage to the product, fire, or injury.
- Do not use the holding brake on the servomotor for braking.
Failure to observe this caution may result in malfunction.
- The servomotor stopping method of turning the main-circuit or control-circuit power OFF without turning the servo OFF during operation can not be set in Parameter Pn001.
For details, refer to 8.4.4 *Stopping Servomotor after SV_OFF Command or Alarm Occurrence* in Σ -V-SD series User's Manual Design and Maintenance Rotational Motor EtherCAT (CoE) Communications Reference (manual no.: SIEP S800000 94).
- Do not establish communications with the host controller while running SigmaWin for Σ -V-SD (MT), because an alarm or warning might be issued.
If an alarm or warning is issued, any process currently being executed might be aborted and the system might also be stopped.
Only when using the following functions, communications with the host controller is allowed while running SigmaWin for Σ -V-SD (MT).
<functions for use with SigmaWin for Σ -V-SD (MT) that require communications with the host controller during use>
 - Advanced autotuning by reference
 - One-parameter tuning
 - Anti-resonance control adjustment function<functions for use with SigmaWin for Σ -V-SD (MT) that will not result in problems if communications established with the host controller during use>
 - Parameter edit function, excluding parameter initialization
 - Monitor function
 - Alarm display function, excluding resetting alarms and clearing alarm history
 - Data trace function
- Dynamic braking (DB) is an auxiliary function used for emergency stops. It does not guarantee that the servomotor will come to a full or immediate stop as when a brake is applied. The servomotor might coast to a stop. Provide appropriate braking devices on the machine side to ensure safety.
- Do not use the servo drive under a load moment of inertia exceeding the maximum allowable value.
Failure to observe this caution may result in damage or malfunction of resistors and power devices in the SERVOPACK.

■ Maintenance and Inspection

CAUTION

- Do not disassemble the power regeneration converter and SERVOPACK.
Failure to observe this caution may result in electric shock or injury.
- Do not attempt to change wiring while the power is ON.
Failure to observe this caution may result in electric shock or injury.
- When replacing the SERVOPACK, resume operation only after transferring the previous SERVOPACK parameters to the new SERVOPACK.
Failure to observe this caution may result in damage to the product.

■ Disposal

 CAUTION

- When disposing of the products, treat them as ordinary industrial waste.

■ General Precautions

**Observe the following general precautions
to ensure safe application.**

- The products shown in illustrations in this manual are sometimes shown without covers or protective guards. Always replace the cover or protective guard as specified first, and then operate the products in accordance with the manual.
- The drawings presented in this manual are typical examples and may not match the product you received.
- If the manual must be ordered due to loss or damage, inform your nearest Yaskawa representative or one of the offices listed on the back of this manual.

Warranty

(1) Details of Warranty

■ Warranty Period

The warranty period for a product that was purchased (hereinafter called “delivered product”) is one year from the time of delivery to the location specified by the customer or 18 months from the time of shipment from the Yaskawa factory, whichever is sooner.

■ Warranty Scope

Yaskawa shall replace or repair a defective product free of charge if a defect attributable to Yaskawa occurs during the warranty period above. This warranty does not cover defects caused by the delivered product reaching the end of its service life and replacement of parts that require replacement or that have a limited service life.

This warranty does not cover failures that result from any of the following causes.

1. Improper handling, abuse, or use in unsuitable conditions or in environments not described in product catalogs or manuals, or in any separately agreed-upon specifications
2. Causes not attributable to the delivered product itself
3. Modifications or repairs not performed by Yaskawa
4. Abuse of the delivered product in a manner in which it was not originally intended
5. Causes that were not foreseeable with the scientific and technological understanding at the time of shipment from Yaskawa
6. Events for which Yaskawa is not responsible, such as natural or human-made disasters

(2) Limitations of Liability

1. Yaskawa shall in no event be responsible for any damage or loss of opportunity to the customer that arises due to failure of the delivered product.
2. Yaskawa shall not be responsible for any programs (including parameter settings) or the results of program execution of the programs provided by the user or by a third party for use with programmable Yaskawa products.
3. The information described in product catalogs or manuals is provided for the purpose of the customer purchasing the appropriate product for the intended application. The use thereof does not guarantee that there are no infringements of intellectual property rights or other proprietary rights of Yaskawa or third parties, nor does it construe a license.
4. Yaskawa shall not be responsible for any damage arising from infringements of intellectual property rights or other proprietary rights of third parties as a result of using the information described in catalogs or manuals.

(3) Suitability for Use

1. It is the customer's responsibility to confirm conformity with any standards, codes, or regulations that apply if the Yaskawa product is used in combination with any other products.
2. The customer must confirm that the Yaskawa product is suitable for the systems, machines, and equipment used by the customer.
3. Consult with Yaskawa to determine whether use in the following applications is acceptable. If use in the application is acceptable, use the product with extra allowance in ratings and specifications, and provide safety measures to minimize hazards in the event of failure.
 - Outdoor use, use involving potential chemical contamination or electrical interference, or use in conditions or environments not described in product catalogs or manuals
 - Nuclear energy control systems, combustion systems, railroad systems, aviation systems, vehicle systems, medical equipment, amusement machines, and installations subject to separate industry or government regulations
 - Systems, machines, and equipment that may present a risk to life or property
 - Systems that require a high degree of reliability, such as systems that supply gas, water, or electricity, or systems that operate continuously 24 hours a day
 - Other systems that require a similar high degree of safety
4. Never use the product for an application involving serious risk to life or property without first ensuring that the system is designed to secure the required level of safety with risk warnings and redundancy, and that the Yaskawa product is properly rated and installed.
5. The circuit examples and other application examples described in product catalogs and manuals are for reference. Check the functionality and safety of the actual devices and equipment to be used before using the product.
6. Read and understand all use prohibitions and precautions, and operate the Yaskawa product correctly to prevent accidental harm to third parties.

(4) Specifications Change

The names, specifications, appearance, and accessories of products in product catalogs and manuals may be changed at any time based on improvements and other reasons. The next editions of the revised catalogs or manuals will be published with updated code numbers. Consult with your Yaskawa representative to confirm the actual specifications before purchasing a product.

CONTENTS

About this Manual	iii
Safety Precautions	vi
Warranty	xii

Chapter 1 Specifications 1-1

1.1 Overview	1-2
1.2 CoE Technical Terms	1-3
1.2.1 CoE Technical Terms	1-3
1.2.2 Data Type	1-4
1.2.3 Data Units	1-4
1.3 Specifications for EtherCAT (CoE) Communications	1-5
1.4 LED Indicators	1-6

Chapter 2 EtherCAT Communications 2-1

2.1 CANopen over EtherCAT Device Architecture	2-2
2.2 EtherCAT Slave Information	2-3
2.3 EtherCAT State Machine	2-4
2.4 Object Number for Multi-Axis SERVOPACKs	2-5
2.5 PDO Mapping	2-6
2.6 Synchronization with Distributed Clocks	2-8
2.7 Emergency Messages	2-10

Chapter 3 CiA402 Drive Profile 3-1

3.1 Device Control	3-2
3.2 Modes of Operation	3-4
3.3 Position Control Modes	3-5
3.3.1 Profile Position Mode	3-5
3.3.2 Interpolated Position Mode	3-7
3.3.3 Cyclic Synchronous Position Mode	3-8
3.4 Homing	3-9
3.5 Velocity Control Modes	3-12
3.5.1 Profile Velocity Mode	3-12
3.5.2 Cyclic Synchronous Velocity Mode	3-13
3.6 Torque Control Modes	3-14
3.6.1 Profile Torque Mode	3-14
3.6.2 Cyclic Sync Torque Mode	3-15
3.7 Torque Limit Function	3-16
3.8 Digital Inputs	3-16
3.9 Touch Probe Function	3-17
3.10 Fully-closed Control	3-19
3.11 Hard Wire Base Block (HWBB) Function	3-19

Chapter 4 Object Dictionary	4-1
4.1 Object Dictionary List	4-2
4.2 General Objects	4-4
4.3 PDO Mapping Objects	4-8
4.4 Sync Manager Communication Objects	4-10
4.5 Manufacturer Specific Objects	4-13
4.6 Machine Tools Object (23C8h)	4-19
4.7 Device Control	4-20
4.8 Profile Position Mode	4-28
4.9 Homing Mode	4-30
4.10 Position Control Function	4-32
4.11 Interpolated Position Mode	4-34
4.12 Cyclic Synchronous Position Mode	4-34
4.13 Profile Velocity/Cyclic Synchronous Velocity Mode	4-35
4.14 Profile Torque/Cyclic Synchronous Torque Mode	4-36
4.15 Torque Limit Function	4-37
4.16 Touch Probe Function	4-38
4.17 Digital Inputs (60FDh)	4-40

Chapter 5 Appendix	5-1
5.1 Object List	5-2
5.2 SERVOPACK Parameters	5-8
5.3 SDO Abort Code List	5-8
5.4 Index Numbers and Corresponding Parameter Numbers	5-9

Index	Index-1
------------------------	----------------

Revision History

Specifications

1.1 Overview	1-2
1.2 CoE Technical Terms	1-3
1.2.1 CoE Technical Terms	1-3
1.2.2 Data Type	1-4
1.2.3 Data Units	1-4
1.3 Specifications for EtherCAT (CoE) Communications	1-5
1.4 LED Indicators	1-6

1.1 Overview

A Σ -V-SD SERVOPACK with EtherCAT (CoE) communications references that is used with a rotational motor implements the CANopen drive profile (CiA402) in EtherCAT communications (real-time Ethernet communications).

In addition to basic position, velocity, and torque control, synchronous position, velocity, and torque control can be performed. You can select the appropriate form of control for your system, from simple positioning to high-speed, high-precision locus control.

Moreover, the Σ -V-SD high servo control performance, advanced tuning function, and wide range of actuator controls can be performed via EtherCAT.

1.2 CoE Technical Terms

1.2.1 CoE Technical Terms

This table lists the terms used in this manual for the EtherCAT and the CANopen.

Abbreviation	Description
APRD	Auto Increment Physical Read: a command of EtherCAT Data link layer
APWR	Auto Increment Physical Write: a command of EtherCAT Data link layer
APRW	Auto Increment Physical ReadWrite: a command of EtherCAT Data link layer
ARMW	Auto Increment Physical Read Multiple Write: a command of EtherCAT Data link layer
BRD	Broadcast Read: a command of EtherCAT Data link layer
BWR	Broadcast Write: a command of EtherCAT Data link layer
BRW	Broadcast ReadWrite: a command of EtherCAT Data link layer
CiA	CAN in Automation
CoE	CANopen over EtherCAT
DC	Distributed Clocks Mechanism to synchronize EtherCAT slaves and master
ECAT	EtherCAT
EEPROM	Electrically Erasable Programmable Read Only Memory
ESC	EtherCAT Slave Controller
ESM	EtherCAT State Machine
ETG	EtherCAT Technology Group (http://www.ethercat.org)
EtherCAT	Real-time Standard for Industrial Ethernet Control Automation Technology (Ethernet for Control Automation Technology)
FMMU	Fieldbus Memory Management Unit
FPRD	Configured Address Physical Read: a command of EtherCAT Data link layer
FPWR	Configured Address Physical Write: a command of EtherCAT Data link layer
FPRW	Configured Address Physical ReadWrite: a command of EtherCAT Data link layer
FRMW	Configured Address Physical Read Multiple Write: a command of EtherCAT Data link layer
INIT	INIT state of EtherCAT state machine
LRD	Logical Read: a command of EtherCAT Data link layer
LWR	Logical Write: a command of EtherCAT Data link layer
LRW	Logical ReadWrite: a command of EtherCAT Data link layer
OP	Operational state of EtherCAT state machine
OD	Object Dictionary
PDO	Process Data Object
PREOP	Pre-Operational state of EtherCAT state machine
Process data	Collection of application objects designated to be transferred cyclically for the purpose of measurement and control
RJ45	FCC Registered Jack, standard Ethernet connector
RXPDO	Receive PDO, i.e. Process Data that will be received by ESC
SAFEOP	Safe-Operational state of EtherCAT state machine
SDO	Service Data Object
SyncManager	ESC unit for coordinated data exchange between master and slave controller
TXPDO	Transmit PDO, i.e. Process Data that will be transmitted by ESC

1.2.2 Data Type

This table lists the data types and ranges used in this manual.

Code	Data Type	Range
SINT	Signed 8 bit	-128 to +127
INT	Signed 16 bit	-32768 to +32767
DINT	Signed 32 bit	-2147483648 to +2147483627
USINT	Unsigned 8 bit	0 to 255
UINT	Unsigned 16 bit	0 to 65535
UDINT	Unsigned 32 bit	0 to 4294967295
STRING	String value	–

1.2.3 Data Units

This table describes the data units used in this manual.

Units	Description
Pos. unit	This is the user-defined position reference unit set by object 2301h. 1 [Pos. unit] = 2301:01h/2301:02h [inc]
Vel. unit	This is the user-defined velocity reference unit set by object 2302h. 1 [Vel. unit] = 2302:01h/2302:02h [inc/sec]
Acc. unit	This is the user-defined acceleration reference unit set by object 2303h. 1 [Acc. unit] = 2303:01h/2303:02h $\times 10^4$ [inc/sec ²]
inc	This is the encoder pulse unit. For a 20-bit encoder, the resolution will be 1048576 [inc] per revolution.

1.3 Specifications for EtherCAT (CoE) Communications

	Item	Specification
EtherCAT Communications	Applicable Communication Standards	IEC 61158 Type12, IEC 61800-7 CiA402 Drive Profile
	Physical Layer	100BASE-TX (IEEE802.3)
	Fieldbus Connection	CN9A (RJ45): EtherCAT Signal IN CN9B (RJ45): EtherCAT Signal OUT
	Cable	CAT5 STP 4 pair (Cables are automatically recognized by the AUTO MDIX function.)
	SyncManager	SM0: Mailbox output, SM1: Mailbox input SM2: Process data outputs, SM3: Process data inputs
	FMMU	FMMU0: Mapped to the process data output (RxPDO) area. FMMU1: Mapped to the process data input (TxPDO) area. FMMU2: Mapped to the mailbox status
	EtherCAT Commands (Data Link Layer)	APRD, FPRD, BRD, LRD, APWR, FPWR, BWR, LWR, ARMW, FRMW Note: APRW, FPRW, BRW, LRW Commands are not supported.
	Process Data	Configurations can be changed with PDO mapping.
	Mailbox (CoE)	Emergency Message, SDO Request, SDO Response, SDO information Note: TxPDO/RxPDO and Remote TxPDO/RxPDO are not supported.
	Distributed Clocks	Free-run, DC mode (Can be selected.) Supported DC cycle: 250 μ s to 4 ms (every 250- μ s cycle)
	Slave Information IF	256 bytes (For reading only)
CiA402 Drive Profile	LED Indicator	EtherCAT Link/Activity indicator (L/A) \times 2 EtherCAT RUN indicator (RUN) \times 1 EtherCAT ERR indicator (ERR) \times 1
		<ul style="list-style-type: none"> • Homing mode • Profile position mode • Interpolated position mode • Profile velocity mode • Profile torque mode • Cyclic synchronous position mode • Cyclic synchronous velocity mode • Cyclic synchronous torque mode • Touch probe function • Torque limit function

1.4 LED Indicators

This diagram shows details of the LED indicators.

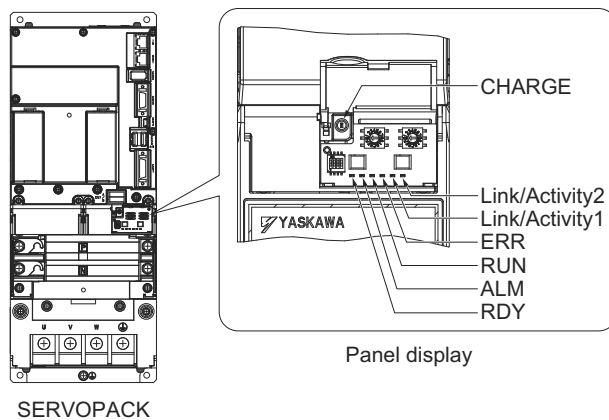

Name	LED Color	Meaning
CHARGE	Orange	Lit when main circuit power is on. Not lit when main circuit power is off.
RDY	Green	Lit when CPU of SERVOPACK works normally. Not lit when CPU of SERVOPACK not working.
ALM	Red	Lit when alarm occurs. Not lit when no alarm occurs.
RUN	Green	Indicates the status of EtherCAT (CoE) communications. For details, refer to ■ <i>RUN</i> .
ERR	Red	Indicates the status of EtherCAT (CoE) communications errors. For details, refer to ■ <i>ERR</i> .
Link/ Activity1	Green	Indicates whether a communications cable is connected to the CN9A connector and whether communications are active. For details, refer to ■ <i>Link/Activity</i> .
Link/ Activity2		Indicates whether a communications cable is connected to the CN9B connector and whether communications are active. For details, refer to ■ <i>Link/Activity</i> .

■ RUN

The RUN indicator shows the status of EtherCAT communications.

LED Indicator		Description
Display	Pattern	
Off	Continuously OFF	The EtherCAT (CoE) communication is in Init state.
Blinking		The EtherCAT (CoE) communication is in Pre-Operational state.
Single flash		The EtherCAT (CoE) communication is in Safe-Operational state.
On	Continuously ON	The EtherCAT (CoE) communication is in Operational state.
Flickering		The EtherCAT (CoE) communication is booting and has not yet entered the Init state.

■ ERR

The ERR indicator shows the error status of EtherCAT communications.

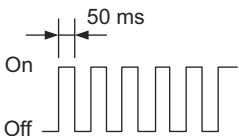
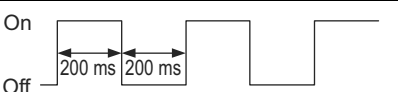
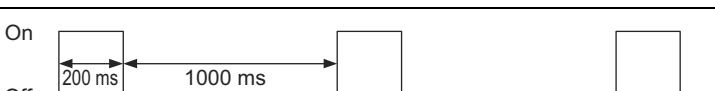
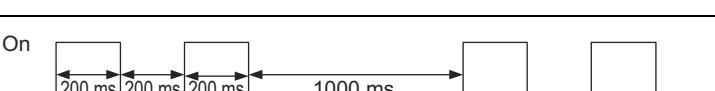
LED Indicator		Description
Display	Pattern	
Off	Continuously OFF	The EtherCAT communication is in working condition.
Flickering		Booting Error was detected.
Blinking		State change commanded by master is impossible due to register or object settings.
Single flash		Synchronization Error, the EtherCAT (CoE) communication enters Safe-Operational state automatically.
Double flash		An application (Sync Manager) watchdog timeout has occurred.
On	Continuously ON	A PDI Watchdog timeout has occurred.

■ Link/Activity

Indicates whether a communications cable is connected to the CN9A or CN9B connectors and whether communications are active.

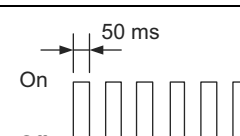
LED Indicator		Description
Display	Pattern	
Off	Continuously OFF	A communication cable is not physically connected. A EtherCAT (CoE) controller is not started up.
Flickering		Data are being exchanged.
On	Continuously ON	A communication cable is physically connected, but no data being exchanged.

EtherCAT Communications

2.1 CANopen over EtherCAT Device Architecture	2-2
2.2 EtherCAT Slave Information	2-3
2.3 EtherCAT State Machine	2-4
2.4 Object Number for Multi-Axis SERVOPACKs	2-5
2.5 PDO Mapping	2-6
2.6 Synchronization with Distributed Clocks	2-8
2.7 Emergency Messages	2-10

2.1 CANopen over EtherCAT Device Architecture

The following figure shows the device architecture of the CANopen over EtherCAT (CoE) Module.

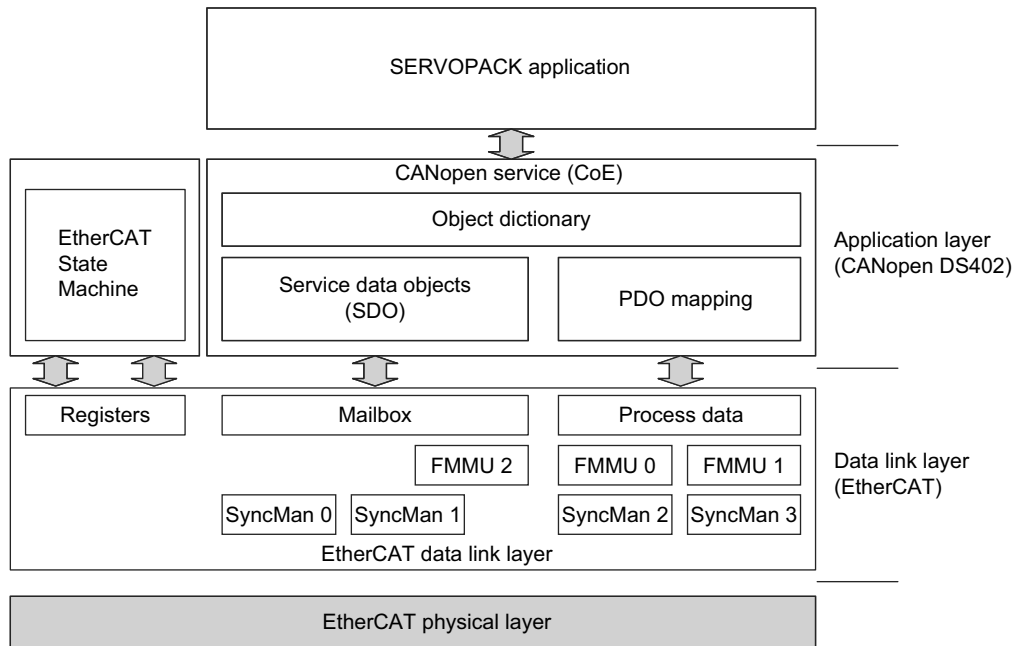

The EtherCAT (CoE) Module is composed of the EtherCAT communication in the data link layer and CANopen drive profile (DS402) in the application layer.

The object dictionary in the application layer includes parameters, application data, and PDO mapping information between the process data interface and the application data.

The process data object (PDO) is composed of objects in the object dictionary that can be mapped to the PDO, and the content of the process data is defined by the PDO mapping.

The process data communication is cyclic communication to write and read the PDO. The mailbox communication (SDO) is acyclic communication to write and read the data entry in the object dictionary.

- Note 1. The EtherCAT (CoE) Module does not support EtherCAT ReadWrite commands (APRW, FPRW, BRW, LRW).
 Note 2. For SDO and PDO communication via EtherCAT data link layer, FMMU and Sync Manager have to configure as follows:

- Sync Manager Settings

Sync Manager	Assignment (Fixed)	Size	Start Address (Fixed)
Sync Manager 0	Assigned to Receive Mailbox	128bytes (fixed)	0x1000
Sync Manager 1	Assigned to Transmit Mailbox	128bytes (fixed)	0x1080
Sync Manager 2	Assigned to Receive PDO	0 to 256bytes	0x1100
Sync Manager 3	Assigned to Transmit PDO	0 to 256bytes	0x1400

- FMMU Settings

FMMU	Settings
FMMU 0	Mapped to Receive PDO
FMMU 1	Mapped to Transmit PDO
FMMU 2	Mapped to Fill Status of Transmit Mailbox

2.2 EtherCAT Slave Information

The EtherCAT Slave Information file (XML file) is available for configuring the EtherCAT master. The XML-based file contains general information about EtherCAT communication settings when setting the SERVOPACK.

The following two files are provided.

Yaskawa_CACR-JU_CoE***.xml

Supplement Information

A SERVOPACK for one axis and a SERVOPACK for two axes use the same file for EtherCAT slave information. The index numbers of a SERVOPACK for one axis are the same as the index numbers for axis 1 of a SERVOPACK for two axes.

2.3 EtherCAT State Machine

The EtherCAT State Machine (ESM) is responsible for the coordination of master and slave applications at start up and during operation. State changes are typically initiated by requests of the master. The states of the EtherCAT State Machine are as follows.

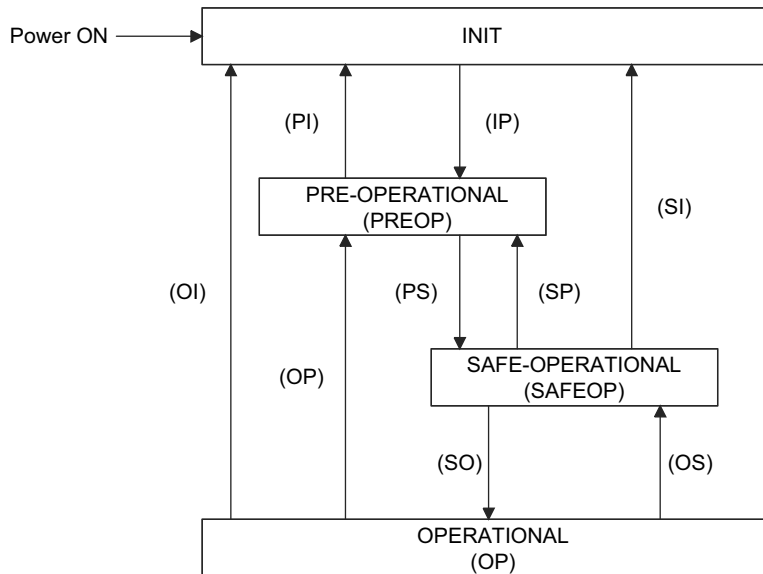

State	Description
INIT	<ul style="list-style-type: none"> No mailbox communication is possible. No process data communication is possible.
INIT => PREOP	<ul style="list-style-type: none"> Master configures DL Address and SyncManager channels for Mailbox communication. Master initializes DC clock synchronization. Master requests 'Pre-Operational' state. Master sets AL Control register. Slave checks whether the mailbox was initialized correctly.
PREOP	<ul style="list-style-type: none"> Mailbox communication is possible. No process data communication is possible.
PREOP => SAFEOP	<ul style="list-style-type: none"> Master configures SyncManager channels and FMMU channels for process data. Master configures PDO mapping and the sync manager PDO assignment parameters via SDO. Master requests 'Safe-Operational' state. Slave checks whether the sync manager channels for process data communication and, if required, the distributed clocks settings are correct.
SAFEOP	<ul style="list-style-type: none"> Mailbox communication is possible. Process Data communication is possible, but only Inputs are evaluated – Outputs remain in 'Safe' state.
SAFEOP => OP	<ul style="list-style-type: none"> Master sends valid Outputs. Master requests 'Operational' state.
OP	<ul style="list-style-type: none"> Mailbox communication is possible. Process data communication is possible.

2.4 Object Number for Multi-Axis SERVOPACKs

If a SERVOPACK for two axes is used with more than one axis (multiple axes), the objects for each axis are defined by the following rules.

Axis No	RxPDO	RxPDO Entries		TxPDO	TxPDO Entries	
1	0x1600	0x607A	0x6040	0x1A00	0x6064	0x6041
	↓	↓	↓	↓	↓	↓
	SlotPdoIncrement = 16 (0x10)	SlotIndexIncrement = 0x800		SlotPdoIncrement = 16 (0x10)	SlotIndexIncrement = 0x800	
	↓	↓	↓	↓	↓	↓
2	0x1610	0x687A	0x6840	0x1A10	0x6864	0x6841



IMPORTANT

This manual provides examples with objects for a SERVOPACK for one axis and objects for axis 1 of a SERVOPACK for two axes. Substitute the object number for the second axis of the SERVOPACK when reading this manual.

2.5 PDO Mapping

PDO mapping refers to the mapping of application objects (real time process data) from the object dictionary to the PDOs.
 The PDO mapping tables are allocated to index 1600h for the RxPDOs and 1A00h for the TxPDOs in the object dictionary.

The following figure shows an example of a PDO mapping.

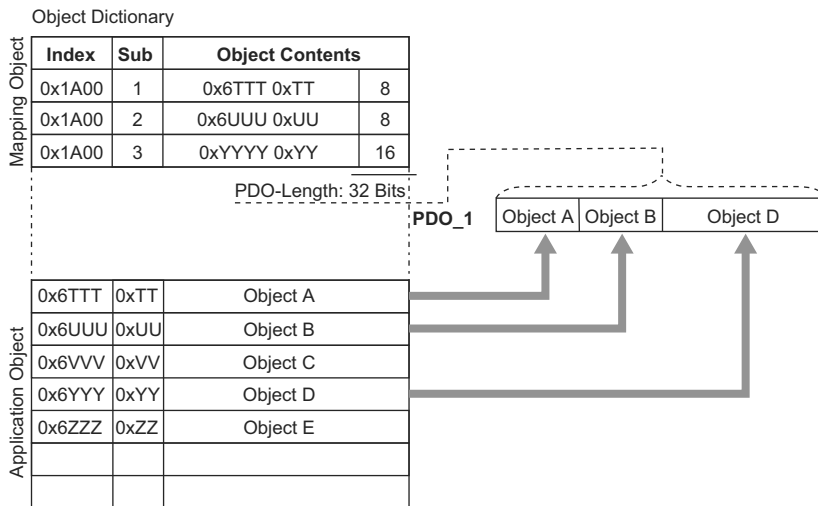

In addition to above PDO mappings, PDOs have to be assigned to Sync Manager for the EtherCAT process data exchange.

The Sync Manager PDO Assign objects (1C12h and 1C13h) establish the relationship between these PDOs and the Sync Manager.

The following figure shows an example of Sync Manager PDO mappings.

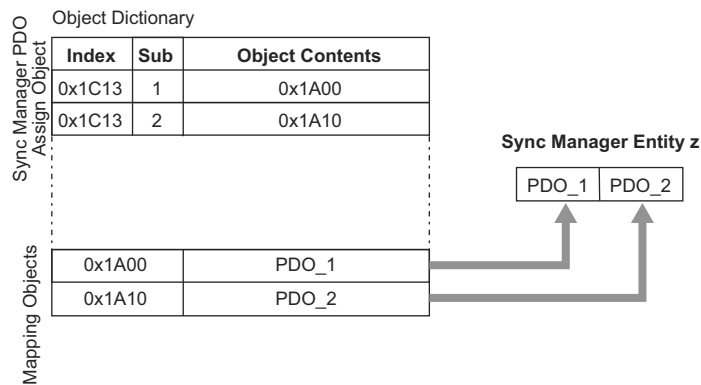

CAUTION

The PDO mapping objects (index 1600h and 1A00h) and the Sync Manager PDO assign objects (index 1C12h and 1C13h) can be written only in Pre-Operation state.

■ Setup Procedure of PDO Mapping

1. Disable the assignment of the Sync manager and PDO (Set subindex 0 of object 1C12h and 1C13h to 0).
2. Set all the mapping entry in PDO mapping objects (Set object 1600h and 1A00h).
3. Set the number of mapping entries in PDO mapping objects (Set subindex 0 of object 1600h and 1A00h).
4. Set the assignment of the Sync manager and PDO (Set subindex 1 of object 1C12h and 1C13h).
5. Enable the assignment of the Sync manager and PDO (Set subindex 0 of object 1C12h and 1C13h to 1).

■ Default PDO Mappings

The following table shows the default PDO mappings.

The default is defined in the EtherCAT Slave Information file (XML file).

1st PDO Mapping (Position, Velocity, Torque, Touch probe, Machine tool)

RxPDO (1600h)	Controlword (6040h)	Target Position (607Ah)	Velocity Offset (60B1h)	Torque Offset (60B2h)	Touch probe function (60B8h)	Machine tool function (23C8h: 1)	
TxPDO (1A00h)	Statusword (6041h)	Position actual value (6064h)	Velocity actual value (606Ch)	Torque actual value (6077h)	Touch probe status (60B9h)	Touch probe value (60BAh)	Machine tool status. (23C8h: 2)

2.6 Synchronization with Distributed Clocks

The synchronization of EtherCAT communication is based on a mechanism called the Distributed Clock. With the Distributed Clock, all devices can be synchronized to each other by sharing the same reference clock (System Time). The slave devices synchronize internal applications to Sync0 event which are generated reference clock.

The following synchronization modes are available in the EtherCAT (CoE) Module. The synchronization mode can be changed by Sync Control registers (ESC register 0x980 and 981).

- Free-Run (ESC register: 0x980 = 0x0000)
In Free Run mode, the local cycle runs independently from the communication cycle and master cycle.
- DC Mode (ESC register: 0x980 = 0x0300)
In this mode, the SERVOPACK can be synchronized to the EtherCAT master with the Sync0 event.

The following figure shows timing chart of this DC synchronization.

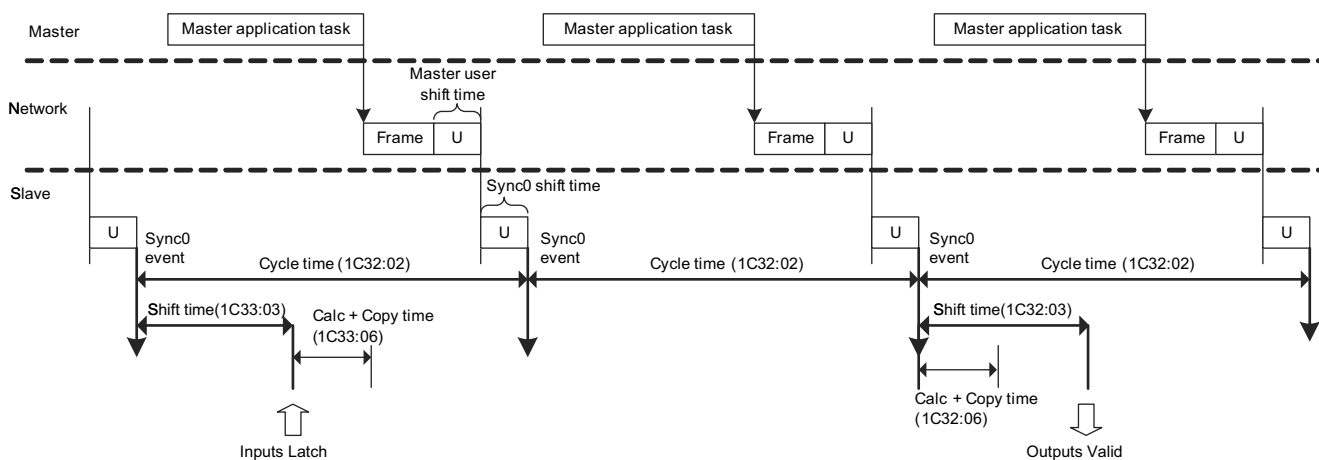

Index	Sub	Name	Access	PDO Mapping	Type	Value
1C32h Sync Manager channel 2 (process data output) Synchronization						
	1	Synchronization type	RO	No	UINT	Current status of DC mode 0: Free-run 2: DC Mode (Synchronous with Sync0)
	2	Cycle time	RO	No	UDINT	Sync0 event cycle [ns] (The value is set by master via ESC register.) range: 250000*n (n = 1-16) [ns]
	3	Shift time	RO	No	UDINT	125000 [ns] (Fixed value) Time between Sync0 event and the Outputs Valid (At the Outputs Valid the outputs are available for the SERVOPACK.)
	5	Minimum cycle time	RO	No	UDINT	250000 [ns] Minimum allowable time between Sync0 event and the next frame.
	6	Calc and copy time	RO	No	UDINT	62500 [ns] (Fixed value) Time for reading the outputs from SyncManager 2 at Sync0 event
	9	Delay time	RO	No	UDINT	125000 [ns] Time between Outputs Valid and Current Outputs.

(cont'd)

Index	Sub	Name	Access	PDO Mapping	Type	Value
1C33h Sync Manager channel 3 (process data input) Synchronization						
	3	Shift time	RW	No	UDINT	125000*n (n = 1–32) [ns] Range: 0 to (Synq0 event cycle - 125000) [ns] Time between Sync0 event and the Inputs Latch. (At the Inputs Latch the inputs are acquired from the SERVOPACK.)
	6	Calc and copy time	RO	No	UDINT	62500 [ns] (Fixed value) Time for the copying of the input process data to the SyncManager 3 area.
	9	Delay time	RO	No	UDINT	125000 [ns] Time between Encoder Read and Inputs Latch.

■ Example of PDO Data Exchange Timing with DC Mode

- DC Cycle Time = 1 ms, Input Shift Time = 375 μs

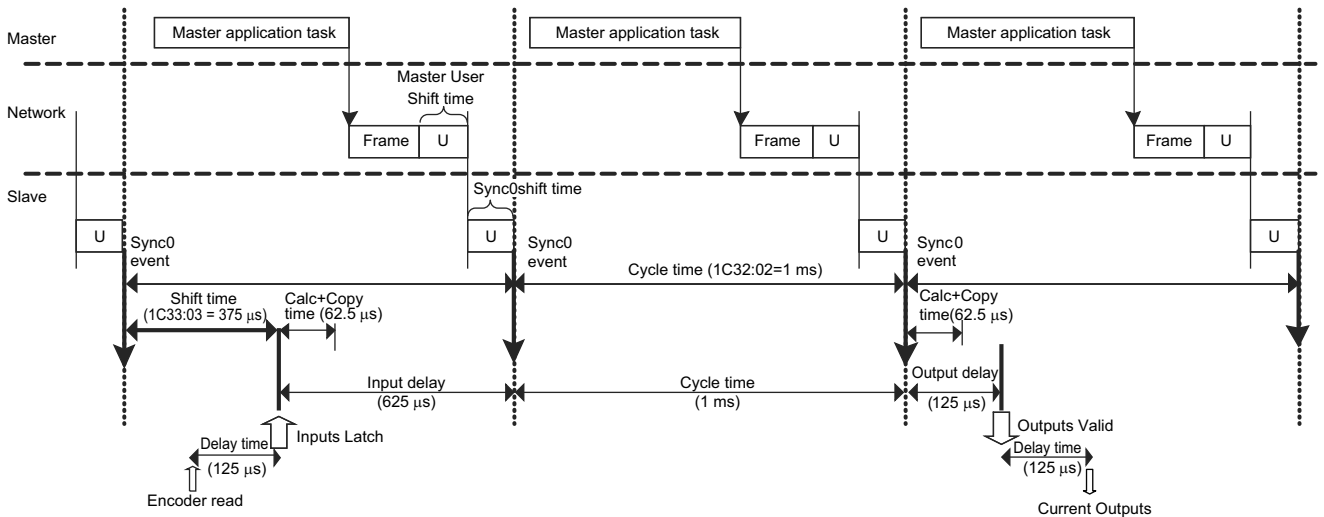

- DC Cycle Time = 250 μs, Input Shift Time = 125 μs

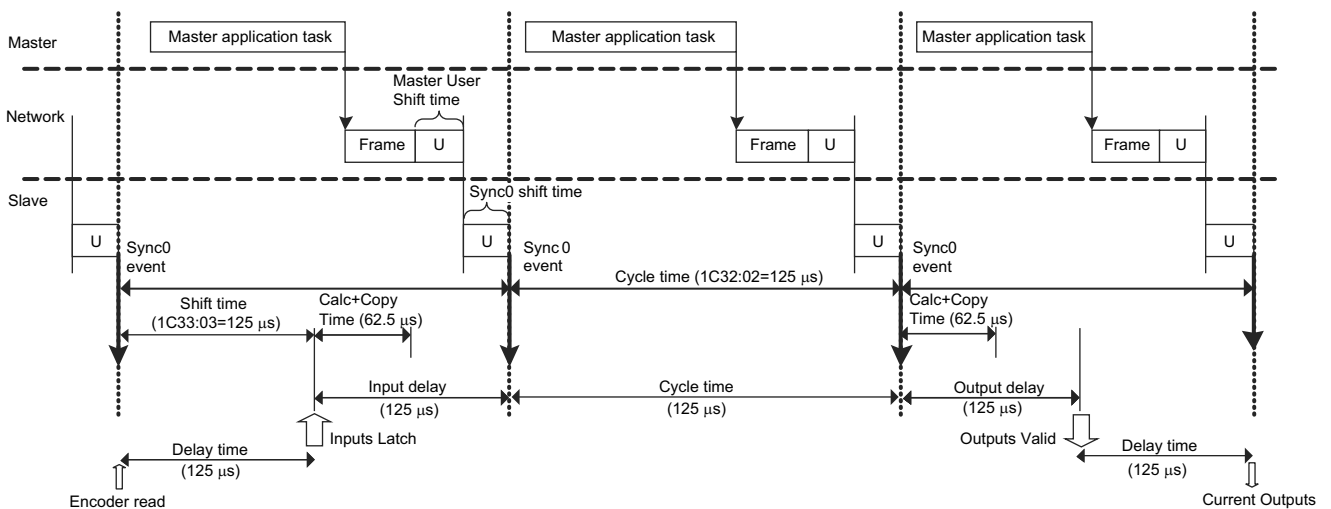

2.7 Emergency Messages

The emergency messages are triggered by the alarms and warnings detected within the SERVOPACK. The transmission is executed via the mailbox interface.

The Emergency Telegram consists of eight bytes with the data as shown in table below:

Byte	0	1	2	3	4	5	6	7
Content	Emergency Error Code (FF00h) * ¹		Error Register (Object 1001h)	Reserved	Manufacturer Specific Error Field			
					SERVOPACK Alarm/Warning Code * ²		Reserved	Axis Number

*1. Manufacturer-specific error code FF00h is always used.

*2. For details on alarms and warnings of the SERVOPACK, refer to *Σ-V-SD series User's Manual Design and Maintenance Rotational Motor EtherCAT (CoE) Communications Reference (manual no.: SIEP S800000 94)*.

CiA402 Drive Profile

3.1 Device Control	3-2
3.2 Modes of Operation	3-4
3.3 Position Control Modes	3-5
3.3.1 Profile Position Mode	3-5
3.3.2 Interpolated Position Mode	3-7
3.3.3 Cyclic Synchronous Position Mode	3-8
3.4 Homing	3-9
3.5 Velocity Control Modes	3-12
3.5.1 Profile Velocity Mode	3-12
3.5.2 Cyclic Synchronous Velocity Mode	3-13
3.6 Torque Control Modes	3-14
3.6.1 Profile Torque Mode	3-14
3.6.2 Cyclic Sync Torque Mode	3-15
3.7 Torque Limit Function	3-16
3.8 Digital Inputs	3-16
3.9 Touch Probe Function	3-17
3.10 Fully-closed Control	3-19
3.11 Hard Wire Base Block (HWBB) Function	3-19

(1) State Machine Controlling Command

Command	Bits of the Controlword (6040h)				
	Bit7	Bit3	Bit2	Bit1	Bit0
Shutdown	0	–	1	1	0
Switch on	0	0	1	1	1
Switch on + Enable operation	0	1	1	1	1
Disable voltage	0	–	–	0	–
Quick stop	0	–	0	1	–
Disable operation	0	0	1	1	1
Enable operation	0	1	1	1	1
Fault reset	0 → 1	–	–	–	–

(2) Bits of Statusword (6041h)

Bit No	Data Description	Note
0	Ready to switch on	For details, refer to 4.7 (3) Statusword (6041h).
1	Switched on	
2	Operation enabled	
3	Fault	
4	Voltage enabled	
5	Quick stop	
6	Switch on disabled	
7	Warning	
8	Reserved	
9	Remote	
10	Target reached	
11	Internal limit active	
12	Operation mode specific	
13		
14	Torque limit active	
15	HWBB active	

(3) Related Objects

Index	Sub	Name	Access	PDO Mapping	Units	Type
6040h	–	Controlword	RW	Yes	–	UINT
6041h	–	Statusword	RO	Yes	–	UINT
605Ah	–	Quick Stop Option Code	RW	No	–	INT
605Bh	–	Shutdown Option Code	RW	No	–	INT
605Ch	–	Disable Operation Option Code	RW	No	–	INT
605Dh	–	Halt Option Code	RW	No	–	INT
605Eh	–	Fault Reaction Option Code	RW	No	–	INT

3.2 Modes of Operation

The SERVOPACK supports the following modes of operation:

- Profile Position mode
- Homing mode
- Interpolated Position mode
- Profile Velocity mode
- Torque Profile mode
- Cyclic Sync Position mode
- Cyclic Sync Velocity mode
- Cyclic Sync Torque mode

■ Related Objects

Index	Sub	Name	Access	PDO Mapping	Units	Type
6060h	–	Modes of Operation	RW	Yes	–	SINT
6061h	–	Modes of Operation Display	RO	Yes	–	SINT
6502h	–	Supported Drive Modes	RO	No	–	UDINT

■ Dynamic Mode Change

The operation mode can be switched by writing the Object 6060h. The master has the responsibility to update all operation mode specific process data objects together with the selection of the operation mode at the same time.

If the master selects a new operation mode, the SERVOPACK changes to the new operation mode immediately.

The following table shows the behavior at the changing a new operation mode from the other mode.

New Operation Mode	Behavior at Changing a New Operation Mode
Profile Position mode	Controlword bit4 = 0: Operation mode is changed, but motor will be stopped. Controlword bit4 = 1: New positioning will be started immediately.
Homing mode	Controlword bit4 = 0: Operation mode is changed, but motor will be stopped. Controlword bit4 = 1: Homing will be started immediately.
Interpolated Position mode	Controlword bit4 = 0: Operation mode is changed, but motor will be stopped. Controlword bit4 = 1: New positioning will be started immediately.
Profile Velocity mode	New operation mode will be started immediately.
Profile Torque mode	New operation mode will be started immediately.
Cyclic Sync Position mode	New operation mode will be started immediately.
Cyclic Sync Velocity mode	New operation mode will be started immediately.
Cyclic Sync Torque mode	New operation mode will be started immediately.

3.3 Position Control Modes

3.3.1 Profile Position Mode

The Profile Position mode is used to start positioning to the Target position with the Profile velocity and the Profile acceleration.

The following figure shows the block diagram of the Profile Position mode.

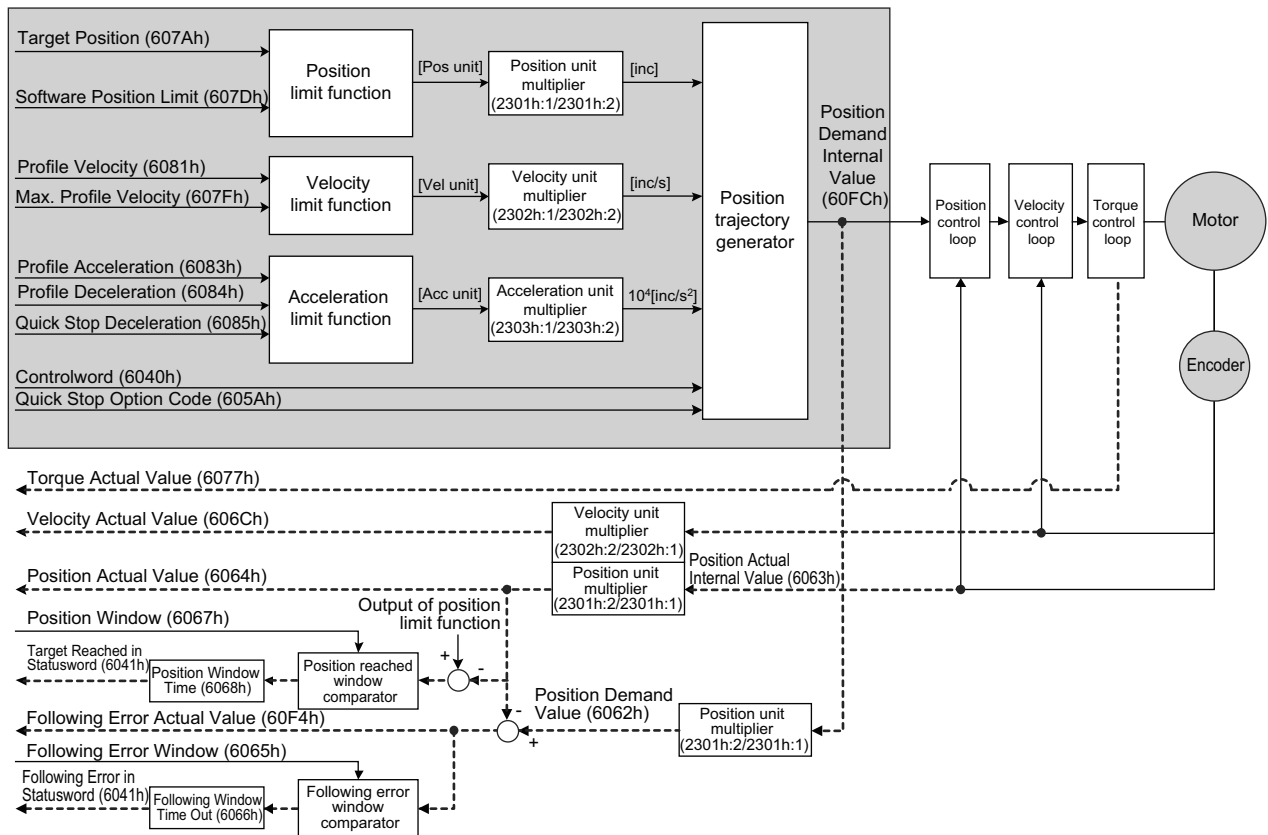

■ Related Objects

Index	Sub	Name	Access	PDO Mapping	Units	Type
6040h	–	Controlword	RW	Yes	–	UINT
6041h	–	Statusword	RO	Yes	–	UINT
607Ah	–	Target Position	RW	Yes	Pos units	DINT
607Dh	–	Software Position Limit	–	–	–	–
	1	Min. position limit	RW	No	Pos units	DINT
	2	Max. position limit	RW	No	Pos units	DINT
607Fh	–	Max. Profile Velocity	RW	Yes	Vel units	UDINT
6081h	–	Profile Velocity	RW	Yes	Vel units	UDINT
6083h	–	Profile Acceleration	RW	Yes	Acc units	UDINT
6084h	–	Profile Deceleration	RW	Yes	Acc units	UDINT
6085h	–	Quick Stop Deceleration	RW	Yes	Acc units	UDINT

In Profile Position mode, the following two methods can be used to start positioning.

- Single Set-point (*change set immediately* bit of Controlword is 1)

When a set-point is in progress and a new set-point is validated by the new set-point (bit 4) in the Controlword, the new set-point shall be processed immediately.

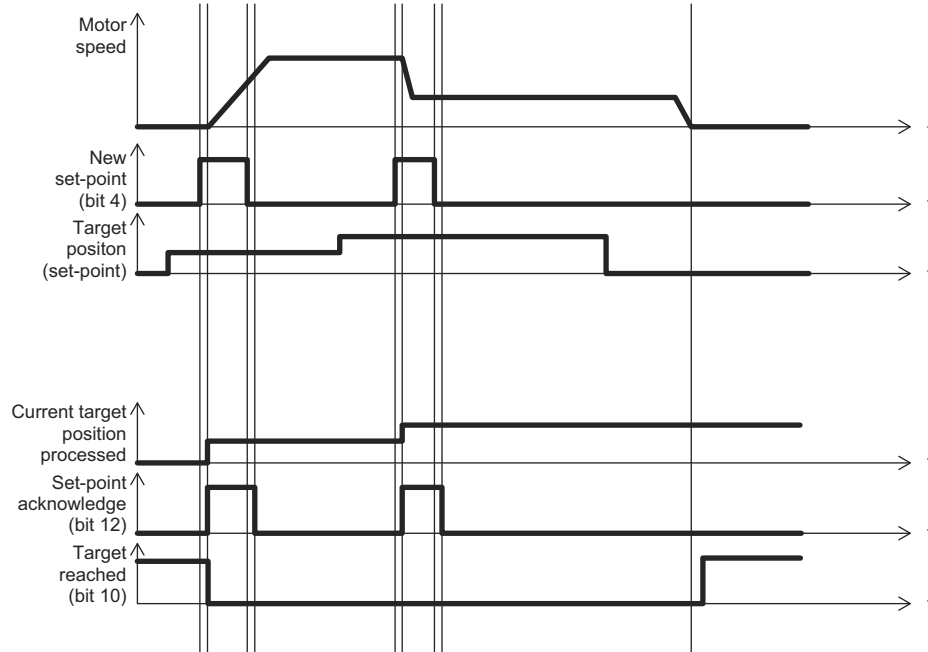

- Set of Set-points (*change set immediately* bit of Controlword is 0)

When a set-point is in progress and a new set-point is validated by the new set-point (bit 4) in the Controlword, the new set-point shall be processed only after the previous has been reached.

The additional dotted line segment in the following figure shows the actual speed if the *change of set point* bit (bit 9) is set to 1.

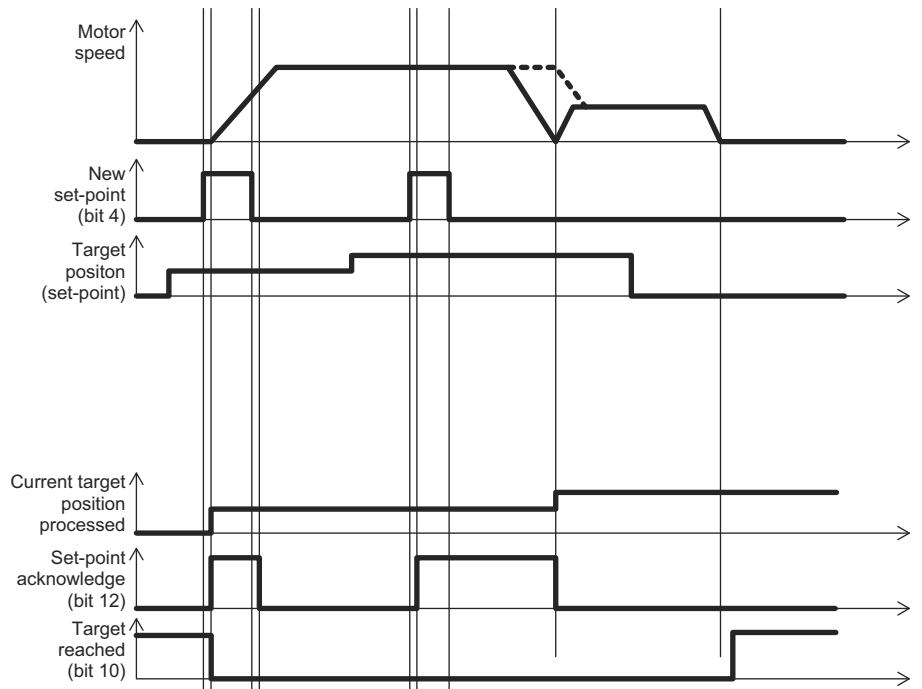

3.3.2 Interpolated Position Mode

The Interpolated Position mode is used to control multiple coordinated axes or a single axis with the need for time-interpolation of set-point data. The Interpolated Position mode normally uses time synchronization mechanisms for a time coordination of the related drive units.

The interpolation time period defines the update cycle of the interpolation data.

The intercycle interpolation will be performed based on this settings.

The interpolation data is interpreted as absolute value.

The following figure shows the block diagram of the Interpolated Position mode.

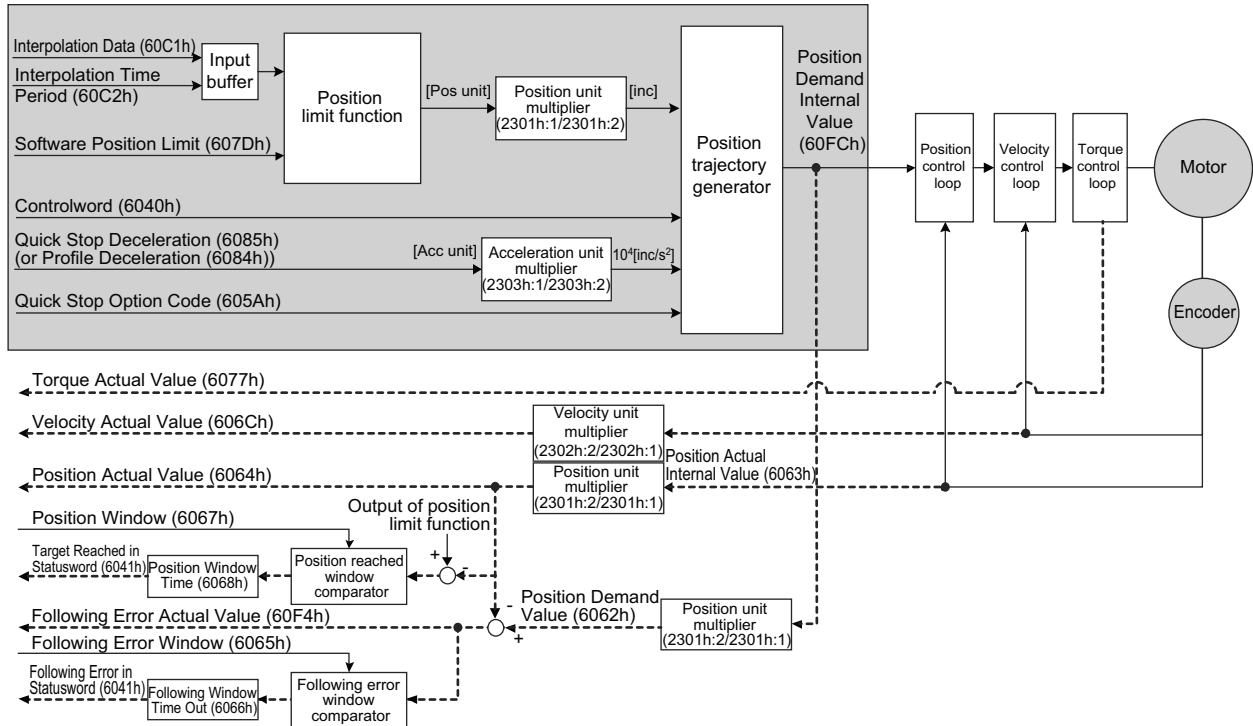

■ Related Objects

Index	Sub	Name	Access	PDO Mapping	Units	Type
6040h	–	Controlword	RW	Yes	–	UINT
6041h	–	Statusword	RO	Yes	–	UINT
60C1h	1	Interpolation Data	RW	Yes	Pos units	DINT
607Dh	–	Software Position Limit	–	–	–	–
	1	Min. position limit	RW	No	Pos units	DINT
	2	Max. position limit	RW	No	Pos units	DINT
6084h	–	Profile Deceleration	RW	Yes	Acc units	UDINT
6085h	–	Quick Stop Deceleration	RW	Yes	Acc units	UDINT
60C2h	–	Interpolation Time Period	–	–	–	–
	1	Interpolation time period	RO	No	–	USINT
	2	Interpolation time index	RO	No	–	SINT

3.3.3 Cyclic Synchronous Position Mode

The Cyclic Synchronous Position mode is used for the interpolated positioning in the same way as Interpolated Position mode. In this mode, additive velocity and torque values can be provided by the master to allow for velocity and torque feed forward.

The interpolation time period defines the interval at which the target position is updated. Interpolation is performed in accordance with this setting.

The target position is interpreted as absolute value.

The following figure shows the block diagram of the Cyclic Synchronous Position mode.

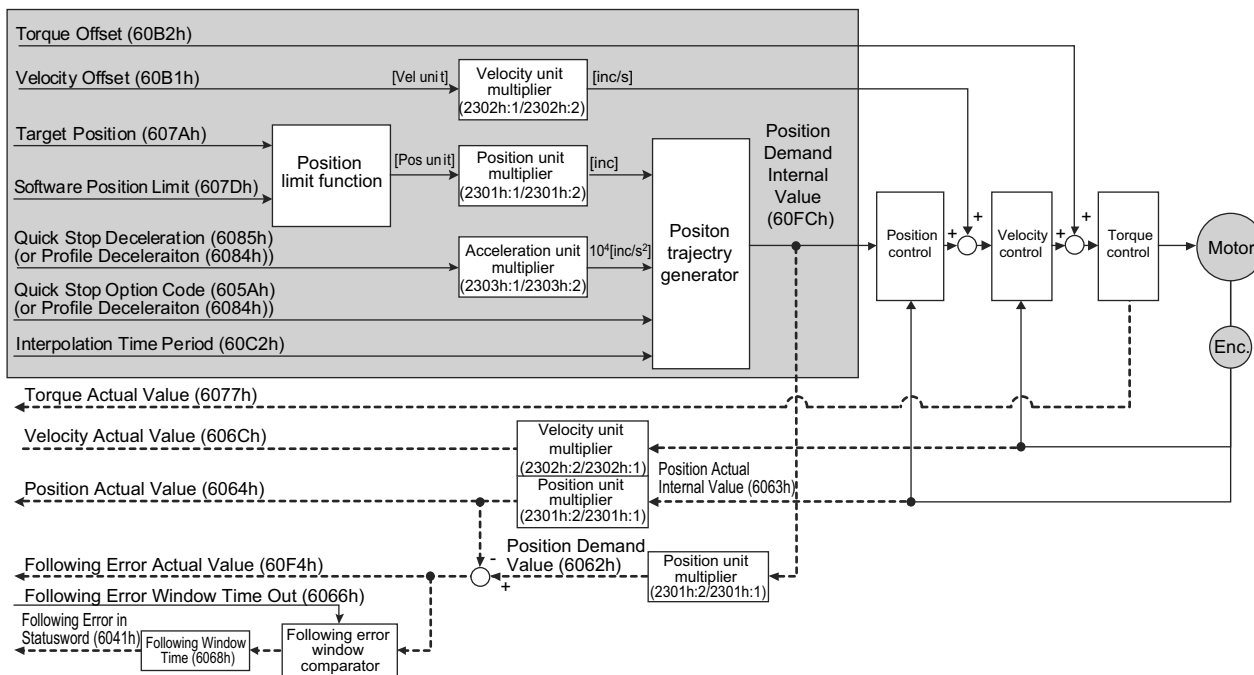

■ Related Objects

Index	Sub	Name	Access	PDO Mapping	Units	Type
607Ah	-	Target Position	RW	Yes	Pos units	DINT
	-	Software Position Limit	-	-	-	-
607Dh	1	Min. position limit	RW	No	Pos units	DINT
	2	Max. position limit	RW	No	Pos units	DINT
6084h	-	Profile Deceleration	RW	Yes	Acc units	UDINT
6085h	-	Quick Stop Deceleration	RW	Yes	Acc units	UDINT
60B1h	-	Velocity Offset	RW	Yes	Vel units	DINT
60B2h	-	Torque Offset	RW	Yes	0.1%*	INT
60C2h	-	Interpolation Time Period	-	-	-	-
	1	Interpolation time period	RO	No	-	USINT
	2	Interpolation time index	RO	No	-	SINT

* The motor rated torque is 100%.

3.4 Homing

The following figure shows the defined input objects as well as the output objects. The user may specify the speeds, acceleration and the method of homing. There is a further object home offset, which allows the user to displace zero in the user's coordinate system from the home position.

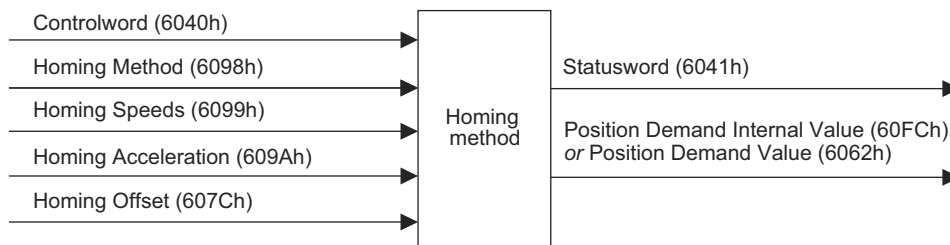

■ Related Objects

Index	Sub	Name	Access	PDO Mapping	Units	Type
6040h	–	Controlword	RW	Yes	–	UINT
6041h	–	Statusword	RO	Yes	–	UINT
607Ch	–	Home Offset	RW	No	Pos units	DINT
6098h	–	Homing Method	RW	Yes	–	SINT
6099h	–	Homing Speeds	–	–	–	–
	1	Speed during search for switch	RW	Yes	Vel units	UDINT
	2	Speed during search for zero	RW	Yes	Vel units	UDINT
609Ah	–	Homing Acceleration	RW	Yes	Acc units	UDINT

■ Homing Method (6098h)

Value	Definitions	Explanation
0	–	No homing (Default value)
1	Homing on the negative limit switch and index pulse	<p>Using this method, the initial direction of movement shall be leftward if the negative limit switch is inactive. The home position shall be at the first index pulse to the right of the position where the negative limit switch becomes inactive.</p> <p>Index pulse</p> <p>Negative limit switch (N-OT)</p>
2	Homing on the positive limit switch and index pulse	<p>Using this method, the initial direction of movement shall be rightward if the positive limit switch is inactive. The position of home shall be at the first index pulse to the left of the position where the positive limit switch becomes inactive.</p> <p>Index pulse</p> <p>Positive limit switch (P-OT)</p>

Note: The index pulse is recognized as the encoder zero signal (phase-C).

(cont'd)

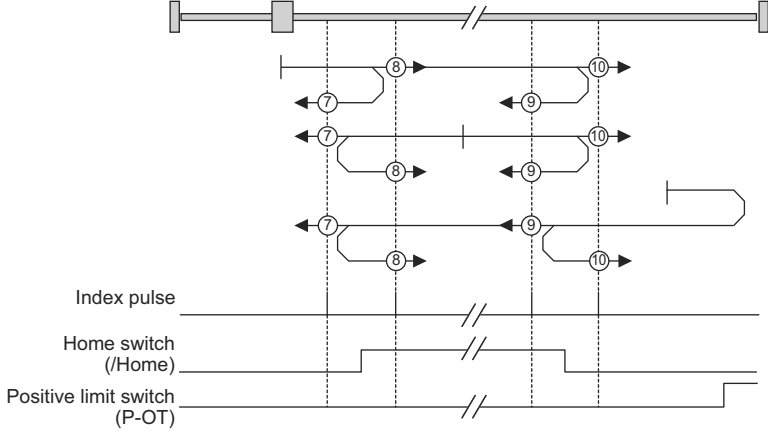
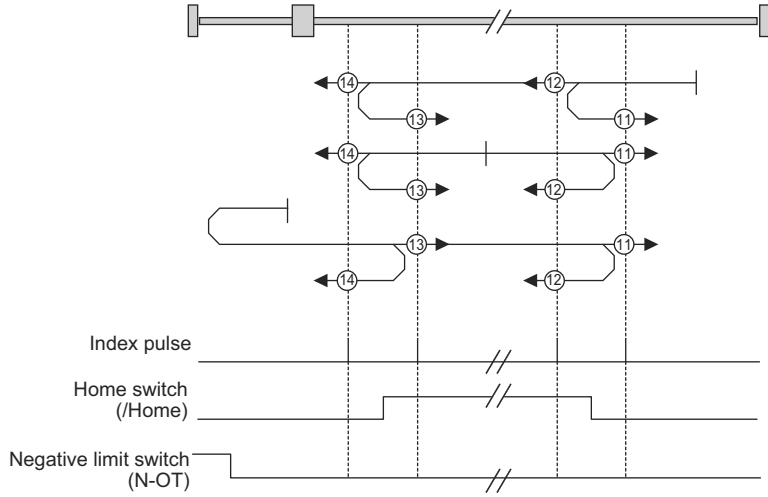
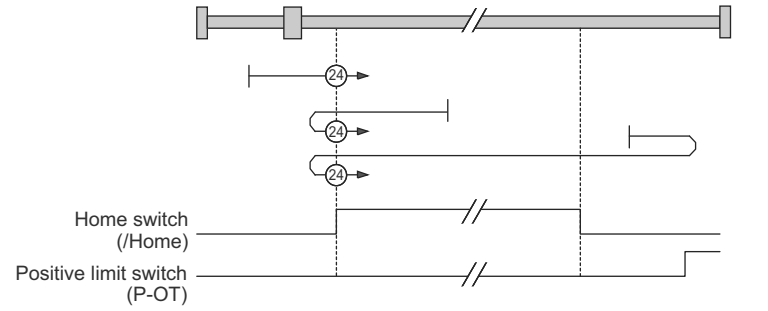
Value	Definitions	Explanation
7 to 10	Homing on home switch and index pulse -positive initial motion	<p>Using the methods 7 to 10, the initial direction of movement shall be to the right except if the home switch is active at the start of the motion. In this case, the initial direction of motion shall be dependent on the edge being sought. The home position shall be at the index pulse on either side of the rising or falling edges of the home switch. If the initial direction of movement leads away from the home switch, the drive shall reverse on encountering the relevant limit switch.</p>  <p>Index pulse</p> <p>Home switch (/Home)</p> <p>Positive limit switch (P-OT)</p>
11 to 14	Homing on home switch and index pulse -negative initial motion	<p>This method is similar to methods 7 to 10 except that the initial direction of movement shall be to the left.</p>  <p>Index pulse</p> <p>Home switch (/Home)</p> <p>Negative limit switch (N-OT)</p>
24	Homing on home switch -positive initial motion	<p>This method is same as method 8 except that the home position does not depend on the index pulse but only depend on the relevant home or limit switch transitions.</p>  <p>Home switch (/Home)</p> <p>Positive limit switch (P-OT)</p>

Note: The index pulse is recognized as the encoder zero signal (phase-C).

(cont'd)

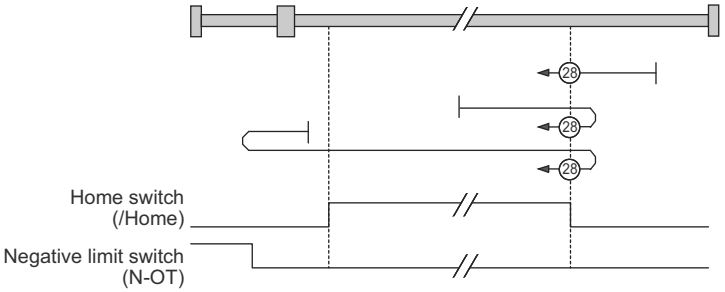
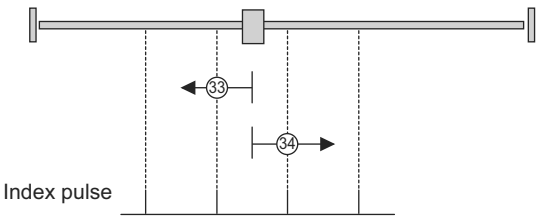
Value	Definitions	Explanation
28	Homing on home switch -negative initial motion	<p>This method is same as method 12 except that the home position does not depend on the index pulse but only depend on the relevant home or limit switch transitions.</p>  <p>Home switch (/Home)</p> <p>Negative limit switch (N-OT)</p>
33, 34	Homing on index pulse	 <p>Index pulse</p>
35	Homing on the current position	<p>In this method, the current position shall be taken to be the home position. This method does not require the drive device to be in <i>operational enabled</i> state.</p>

Note: The index pulse is recognized as the encoder zero signal (phase-C).

3.5 Velocity Control Modes

3.5.1 Profile Velocity Mode

In the Profile Velocity mode, the speed is output in accordance with the Profile acceleration and Profile deceleration, until it reaches the target velocity.

The following figure shows the block diagram of the Profile Velocity mode.

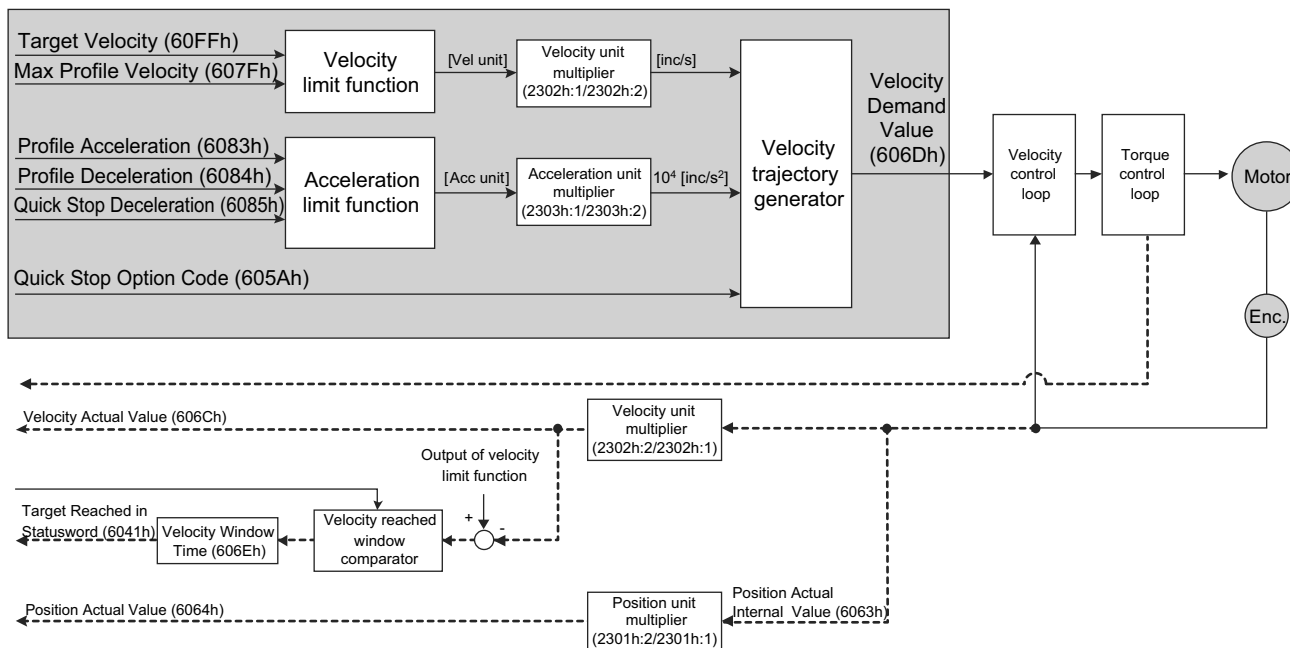

■ Related Objects

Index	Sub	Name	Access	PDO Mapping	Units	Type
60FFh	-	Target Velocity	RW	Yes	Vel units	DINT
607Fh	-	Max. Profile Velocity	RW	Yes	Vel units	UDINT
6083h	-	Profile Acceleration	RW	Yes	Acc units	UDINT
6084h	-	Profile Deceleration	RW	Yes	Acc units	UDINT
6085h	-	Quick Stop Deceleration	RW	Yes	Acc units	UDINT
606Bh	-	Velocity Demand Value	RO	Yes	Vel units	DINT
606Ch	-	Velocity Actual Value	RO	Yes	Vel units	DINT
606Dh	-	Velocity Window	RW	No	Vel units	UINT
606Eh	-	Velocity Window Time	RW	No	ms	UINT

3.5.2 Cyclic Synchronous Velocity Mode

In Cyclic Synchronous Velocity mode, the master provides a target velocity to the drive device, which performs velocity control. In this mode, additive torque values can be provided by the master to allow for torque feed forward.

The following figure shows the block diagram of the Cyclic Synchronous Velocity mode.

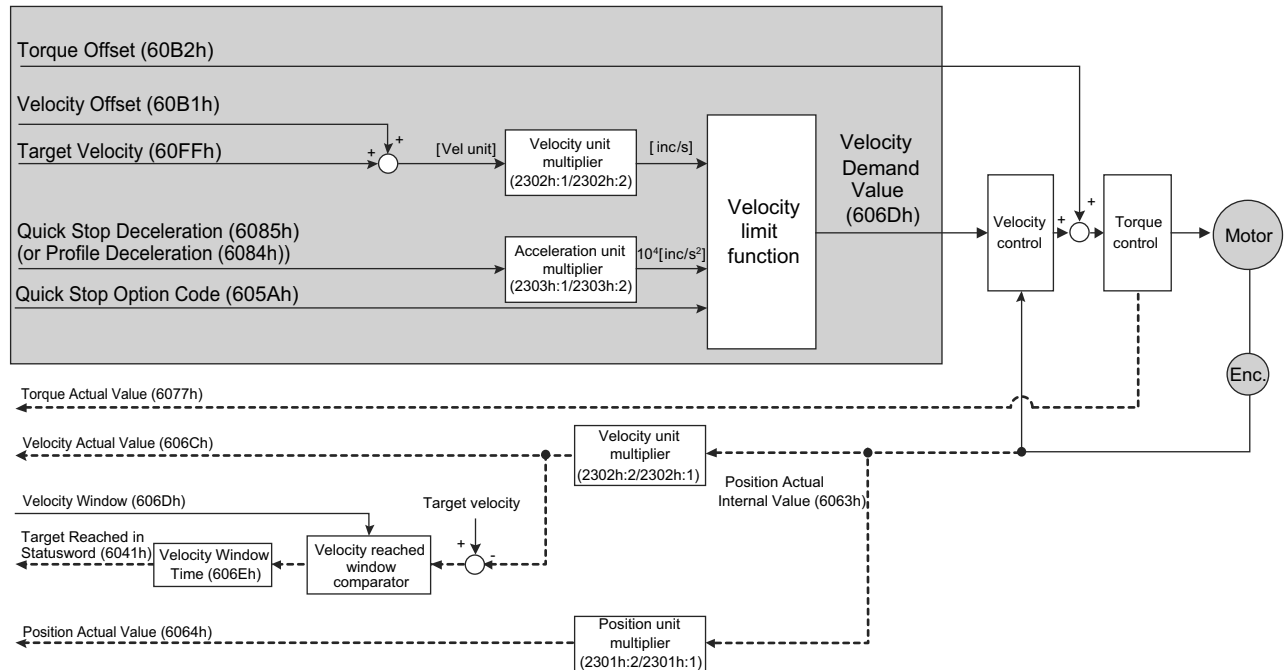

■ Related Objects

Index	Sub	Name	Access	PDO Mapping	Units	Type
60FFh	–	Target Velocity	RW	Yes	Vel units	DINT
60B1h	–	Velocity Offset	RW	Yes	Vel units	DINT
60B2h	–	Torque Offset	RW	Yes	0.1%*	INT
6084h	–	Profile Deceleration	RW	Yes	Acc units	UDINT
6085h	–	Quick Stop Deceleration	RW	Yes	Acc units	UDINT
606Bh	–	Velocity Demand Value	RO	Yes	Vel units	DINT
606Ch	–	Velocity Actual Value	RO	Yes	Vel units	DINT
606Dh	–	Velocity Window	RW	No	Vel units	UINT
606Eh	–	Velocity Window Time	RW	No	ms	UINT

* The motor rated torque is 100%.

3.6 Torque Control Modes

3.6.1 Profile Torque Mode

In the Profile Torque mode, the torque is output to the target torque based on the torque slope setting.

The following figure shows the block diagram of the Profile Torque mode.

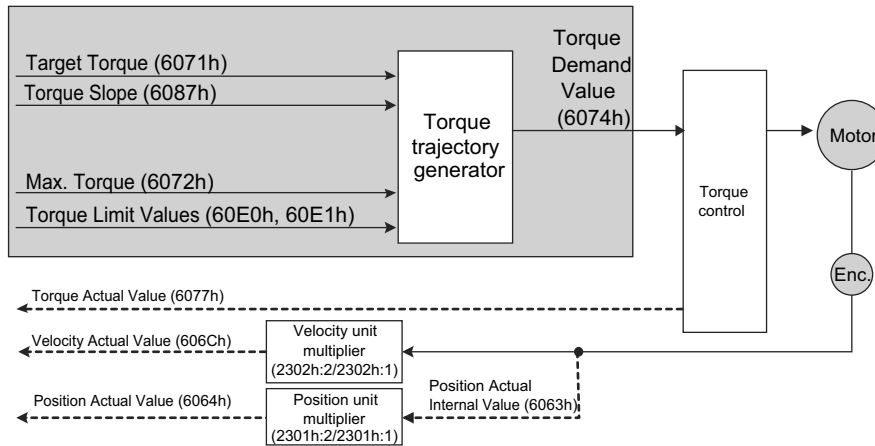

■ Related Objects

Index	Sub	Name	Access	PDO Mapping	Units	Type
6071h	–	Target Torque	RW	Yes	0.1%*	INT
6087h	–	Torque Slope	RW	Yes	0.1%/s*	UDINT
6074h	–	Torque Demand Value	RO	Yes	0.1%*	INT
6077h	–	Torque Actual Value	RO	Yes	0.1%*	INT
6072h	–	Max. Torque	RW	Yes	0.1%*	UINT
60E0h	–	Positive Torque Limit Value	RW	Yes	0.1%*	UINT
60E1h	–	Negative Torque Limit Value	RW	Yes	0.1%*	UINT

* The motor rated torque is 100%.

3.6.2 Cyclic Sync Torque Mode

In Cyclic Synchronous Torque mode, the master provides a target torque to the drive device, which performs torque control.

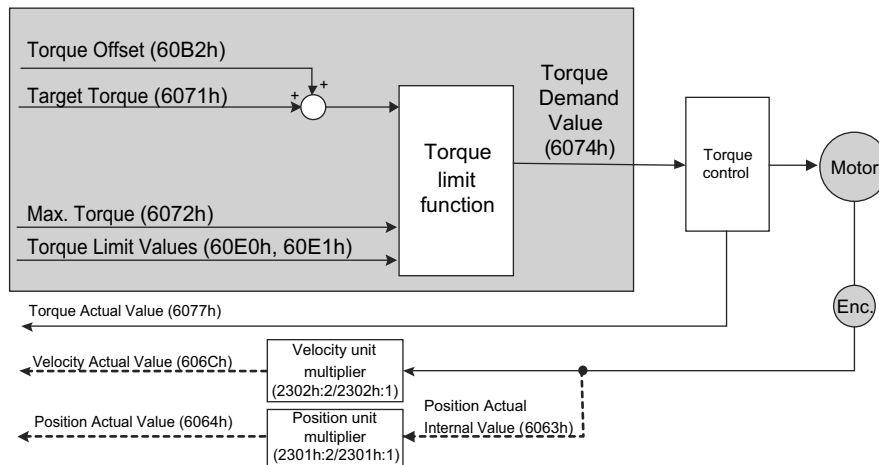

■ Related Objects

Index	Sub	Name	Access	PDO Mapping	Units	Type
6071h	–	Target Torque	RW	Yes	0.1%*	INT
6074h	–	Torque Demand Value	RO	Yes	0.1%*	INT
6077h	–	Torque Actual Value	RO	Yes	0.1%*	INT
60B2h	–	Torque Offset	RW	Yes	0.1%*	INT
6072h	–	Max. Torque	RW	Yes	0.1%*	UINT
60E0h	–	Positive Torque Limit Value	RW	Yes	0.1%*	UINT
60E1h	–	Negative Torque Limit Value	RW	Yes	0.1%*	UINT

* The motor rated torque is 100%.

3.7 Torque Limit Function

The following figure shows the block diagram of the torque limit function. The torque is limited by the lowest limiting values.

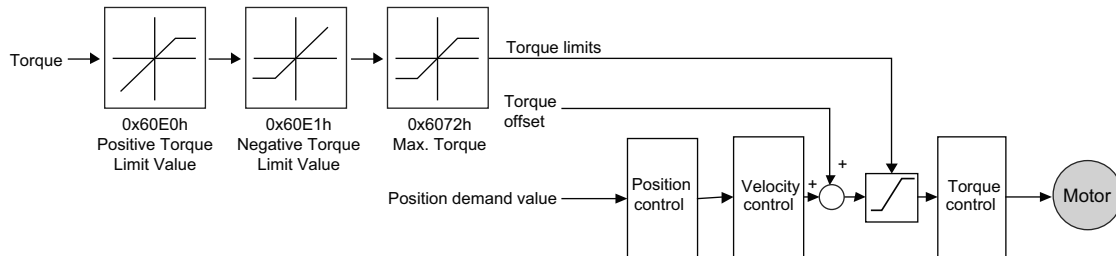

■ Related Objects

Index	Sub	Name	Access	PDO Mapping	Units	Type
6072h	–	Max. Torque	RW	Yes	0.1%*	UINT
60E0h	–	Positive Torque Limit Value	RW	Yes	0.1%*	UINT
60E1h	–	Negative Torque Limit Value	RW	Yes	0.1%*	UINT

* The motor rated torque is 100%.

3.8 Digital Inputs

The Digital Inputs are used to control the I/O signals of the SERVOPACK CN1.

Index	Sub	Name	Access	PDO Mapping	Units	Type
60FDh	–	Digital Inputs	RO	Yes	–	UDINT

3.9 Touch Probe Function

The feedback position can be latched with the following trigger events:

- Trigger with touch probe 1 input (SERVOPACK CN1-2 /Probe1 signal)
- Trigger with touch probe 2 input (SERVOPACK CN1-3 /Probe2 signal)
- Trigger with encoder zero signal (C-phase)

The following two touch probe functions can be used at the same time.

<Touch Probe 1 Latch function>

- Latch Control object: 60B8h (Bit 0 to 7)
- Latch Status object: 60B9h (Bit 0 to 7)
- Latch Position is always stored to the Touch Probe1 Position Value (60BAh).
- Trigger signal: Encoder zero signal or /Probe1 signal

<Touch Probe 2 Latch function>

- Latch Control object: 60B8h (Bit 8 to 15)
- Latch Status object: 60B9h (Bit 8 to 15)
- Latch Position is always stored to the Touch Probe2 Position Value (60BCh).
- Trigger signal: /Probe2 signal

Connector pin allocations and positive/negative logics of /Probe1 and /Probe2 signals can be changed on the SERVOPACK object 2110h: 3 (Pn511).

Note: When the homing function is executing, touch probe 1 function cannot be used. If touch probe 1 function was already enabled, touch probe 1 will be switched off.

■ Related Objects

Index	Sub	Name	Access	PDO Mapping	Units	Type
60B8h	–	Touch Probe Function	RW	Yes	–	UINT
60B9h	–	Touch Probe Status	RO	Yes	–	UINT
60BAh	–	Touch Probe 1 Position Value	RO	Yes	Pos units	DINT
60BCh	–	Touch Probe 2 Position Value	RO	Yes	Pos units	DINT

■ Example of Handshaking Procedure for the Touch Probe Function

- Single Trigger Mode (60B8h bit1 = 0, or bit9 = 0)

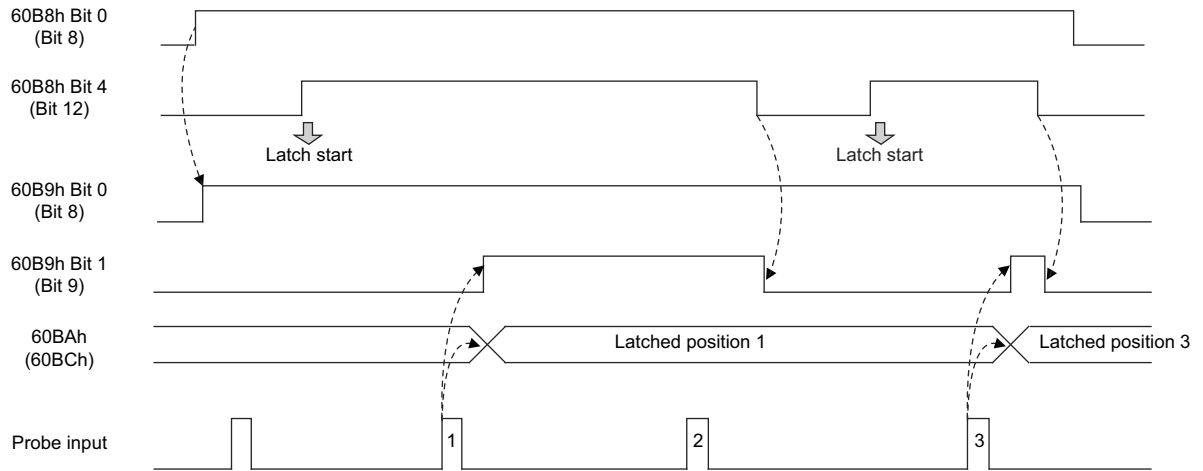

- Continuous Trigger Mode (60B8h bit1 = 1, or bit9 = 1)

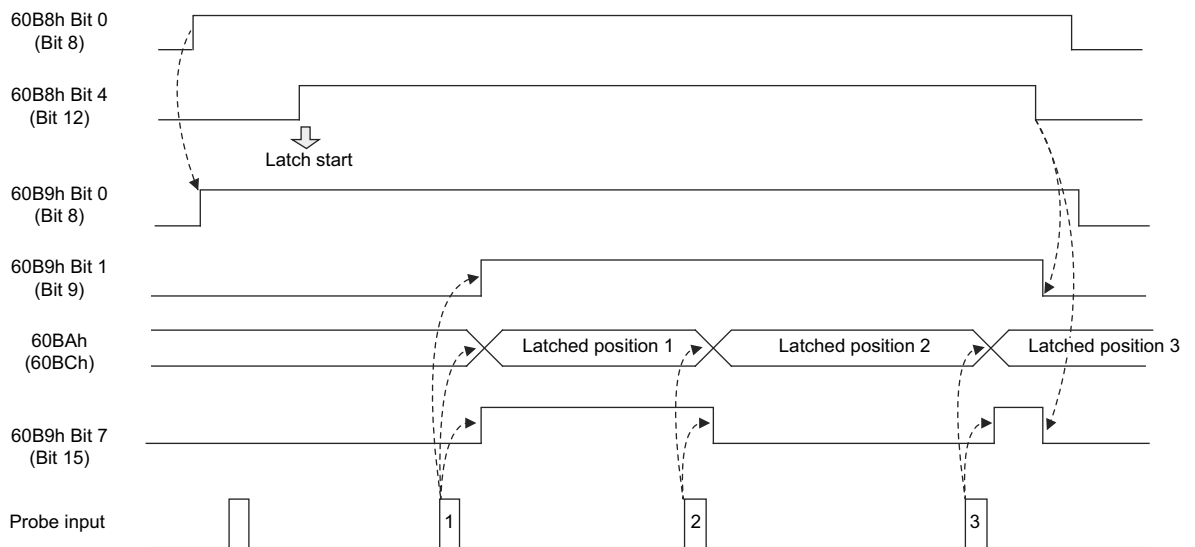

3.10 Fully-closed Control

The following figure shows the block diagram of the fully-closed control.

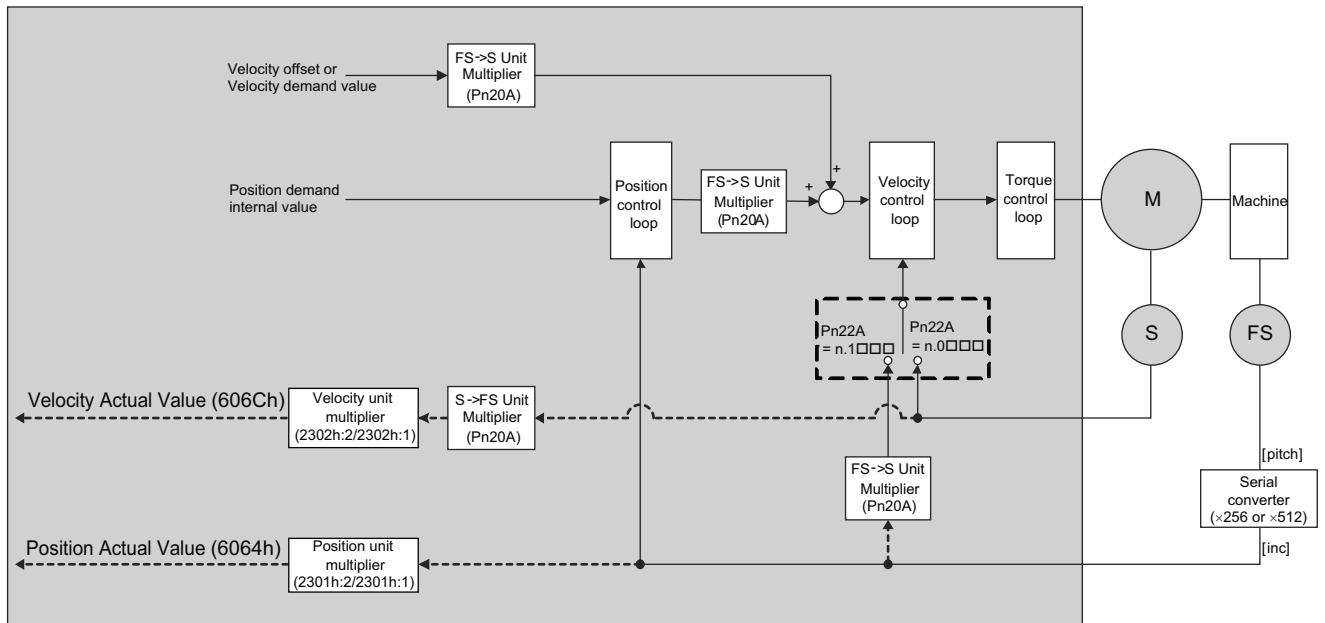

■ Setting Parameters

The basic setting procedure of related parameters is shown below.

Step	Description	Setting Parameters
1	Set the speed feedback method during fully-closed loop control.	Object 2083h (Pn22A)
2	Set the motor rotating direction.	Object 2000h (Pn000.0) Object 2002h (Pn002.3)
3	Set the number of pitches (cycles) of the sine wave for the external scale.	Object 20C1h (Pn20A)
4	Set the alarm detection level for the external encoder.	Object 2102h:5 (Pn51B) Object 2102h:6 (Pn52A)

3.11 Hard Wire Base Block (HWBB) Function

The hard wire base block (HWBB) is a function designed to baseblock the motor (shut off the motor current) with the hardwired circuits.

For details on the HWBB function, refer to 8.8 *Hard Wire Base Block (HWBB) Function in Σ -V-SD series User's Manual Design and Maintenance Rotational Motor EtherCAT (CoE) Communications Reference (manual no.: SIEP S800000 94).*

Object Dictionary

4.1 Object Dictionary List	4-2
4.2 General Objects	4-4
4.3 PDO Mapping Objects	4-8
4.4 Sync Manager Communication Objects	4-10
4.5 Manufacturer Specific Objects	4-13
4.6 Machine Tools Object (23C8h)	4-19
4.7 Device Control	4-20
4.8 Profile Position Mode	4-28
4.9 Homing Mode	4-30
4.10 Position Control Function	4-32
4.11 Interpolated Position Mode	4-34
4.12 Cyclic Synchronous Position Mode	4-34
4.13 Profile Velocity/Cyclic Synchronous Velocity Mode	4-35
4.14 Profile Torque/Cyclic Synchronous Torque Mode	4-36
4.15 Torque Limit Function	4-37
4.16 Touch Probe Function	4-38
4.17 Digital Inputs (60FDh)	4-40

4.1 Object Dictionary List

The following table shows the object dictionaries.

Object Dictionaries		Refer to
General Objects	Device type (1000h)	4.2
	Error register (1001h)	4.2
	Manufacturer device name (1008h)	4.2
	Manufacturer software version (100Ah)	4.2
	Store parameters (1010h)	4.2
	Restore default parameters (1011h)	4.2
	Identity object (1018h)	4.2
PDO Mapping Objects	Receive PDO mapping (1600)	4.3
	Transmit PDO mapping (1A00)	4.3
Sync Manager Communication Objects	Sync manager communication type (1C00h)	4.4
	Sync manager PDO assignment (1C12, 1C13h)	4.4
	Sync manager synchronization (1C32, 1C33h)	4.4
	Sync error setting (10F1h)	4.4
Manufacturer Specific Objects	SERVOPACK parameters (2000-22FFh)	4.5
	User parameter configuration (2300h)	4.5
	Position user unit (2301h)	4.5
	Velocity user unit (2302h)	4.5
	Acceleration user unit (2303h)	4.5
	SERVOPACK adjusting command object (2310h)	4.5
	Machine tools Objects (23C8h)	4.5
Device Control	Error code (603Fh)	4.7
	Controlword (6040h)	4.7
	Statusword (6041h)	4.7
	Quick stop option code (605Ah)	4.7
	Shutdown option code (605Bh)	4.7
	Disable operation option code (605Ch)	4.7
	Halt option code (605Dh)	4.7
	Fault reaction option code (605Eh)	4.7
	Modes of operation (6060h)	4.7
	Modes of operation display (6061h)	4.7
	Supported drive modes (6502h)	4.7
Profile Position Mode	Target position (607Ah)	4.8
	Software position limit (607Dh)	4.8
	Max. profile velocity (607Fh)	4.8
	Profile velocity (6081h)	4.8
	Profile acceleration (6083h)	4.8
	Profile deceleration (6084h)	4.8
	Quick stop deceleration (6085h)	4.8
Homing Mode	Home offset (607Ch)	4.9
	Homing method (6098h)	4.9
	Homing speeds (6099h)	4.9
	Homing acceleration (609Ah)	4.9

(cont'd)

Object Dictionaries		Refer to
Position Control Function	Position demand value (6062h)	4.10
	Position actual internal value (6063h)	4.10
	Position actual value (6064h)	4.10
	Position demand internal value (60FCh)	4.10
	Following error window (6065h)	4.10
	Following error time out (6066h)	4.10
	Following error actual value (60F4h)	4.10
	Position window (6067h)	4.10
	Position window time (6068h)	4.10
Interpolated Position Mode	Interpolation data record (60C1h)	4.11
	Interpolation time period (60C2h)	4.11
Cyclic Synchronous Position Mode	Velocity offset (60B1h)	4.12
	Torque offset (60B2h)	4.12
Profile Velocity/Cyclic Synchronous Velocity Mode	Velocity demand value (606Bh)	4.13
	Velocity actual value (606Ch)	4.13
	Velocity window (606Dh)	4.13
	Velocity window time (606Eh)	4.13
	Target velocity (60FFh)	4.13
Profile Torque/Cyclic Synchronous Velocity Mode	Target torque (6071h)	4.14
	Torque demand value (6074h)	4.14
	Torque slope (6087h)	4.14
	Motor rated torque (6076h)	4.14
	Torque actual value (6077h)	4.14
Torque Limit Function	Max. torque (6072h)	4.15
	Positive torque limit value (60E0h)	4.15
	Negative torque limit value (60E1h)	4.15
Touch Probe Function	Touch probe function (60B8h)	4.16
	Touch probe status (60B9h)	4.16
	Touch probe 1 position value (60BAh)	4.16
	Touch probe 2 position value (60BCh)	4.16
Digital Inputs	Digital inputs (60FDh)	4.17

4.2 General Objects

(1) Device Type (1000h)

The object at index 1000h describes the type of device and its functionality.

Index	Sub	Name	Data Type	Access	PDO Mapping	Value	EEPROM
1000h	0	Device Type	UDINT	RO	No	0x00020192	No

■ Data Description

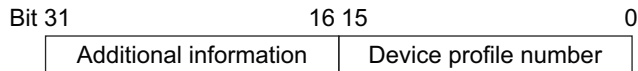

Additional information: 0002 (Servo drive)
Device profile number: 0192 (DS402)

(2) Error Register (1001h)

This object is an error register for the device. The value of this object is stored in a part of emergency message.

Index	Sub	Name	Data Type	Access	PDO Mapping	Value	EEPROM
1001h	0	Error Register	USINT	RO	No	0x00	No

■ Data Description

Bit	Data Meaning	Explanation
0	Generic error	0: No error, 1: Error
1-7	Reserved	0: Always

(3) Manufacturer Device Name (1008h)

This object contains the SERVOPACK model name, such as CACR-JU102ACA.

Index	Sub	Name	Data Type	Access	PDO Mapping	Value	EEPROM
1008h	0	Manufacturer Device Name	STRING	RO	No	–	No

(4) Manufacturer Software Version (100Ah)

This object contains the software version of the SERVOPACK.

Index	Sub	Name	Data Type	Access	PDO Mapping	Value	EEPROM
100Ah	0	Manufacturer Software Version	STRING	RO	No	–	No

■ Data Description

The following string is stored.
“xxxx.*** (D:0000)”

xxxx.***: software version of the EtherCAT (CoE) Module
0000: software version of the SERVOPACK

(5) Store Parameters (1010h)

With this object, the setting value of parameters can be stored in the non-volatile memory.

Index	Sub	Name	Data Type	Access	PDO Mapping	Value	EEPROM
1010h	0	Largest subindex supported	USINT	RO	No	4	No
	1	Save all parameters	UDINT	RW	No	0x00000000 to 0xFFFFFFFF (Default: 0x00000001)	No
	2	Save communication parameters	UDINT	RW	No	0x00000000 to 0xFFFFFFFF (Default: 0x00000001)	No
	3	Save application parameters	UDINT	RW	No	0x00000000 to 0xFFFFFFFF (Default: 0x00000001)	No
	4	Save manufacturer defined parameters	UDINT	RW	No	0x00000000 to 0xFFFFFFFF (Default: 0x00000001)	No

By reading data of an object entry, the SERVOPACK provides its capability to save parameters.

Bit	Value	Meaning
31	0	Last command completed: No errors
	1	Last command completed: Error
1 to 30	0	Reserved
0	0	SERVOPACK does not save parameters when a command is sent.
	1	SERVOPACK saves parameters when a command is sent.

In order to avoid storage of parameters by mistake, storage is only executed when a specific signature is written to the appropriate subindex. The signature that shall be written is “save.”

Signature	MSB	LSB		
ASCII	e	v	a	s
hex	65h	76h	61h	73h

By writing “save” to subindex 1, all parameters are stored.

By writing “save” to subindex 2, the communication parameters (Object 1000h to 1FFFh) are stored.

By writing “save” to subindex 3, the application parameters (Object 23xxh and 6xxxh) are stored.

By writing “save” to subindex 4, the SERVOPACK parameters (Object 2000h to 22FFh) are stored

- Note 1. If a wrong signature is written, the SERVOPACK refuses to store and responds with Abort SDO Transfer.
 2. If the storing parameters are executing, 0 will be returned by read this object.
 3. Subindex 1 and subindex 4 can be written only in Switch on Disabled state (Servo off state).
 4. After the storing parameters by subindex 1 or subindex 4, power on reset or executing the parameter configuration (Object 2300h) is necessary to transit into the Operation Enabled state.

(6) Restore Default Parameters (1011h)

With this object, the default values of parameters can be restored.

Index	Sub	Name	Data Type	Access	PDO Mapping	Value	EEPROM
1011h	0	Largest subindex supported	USINT	RO	No	4	No
	1	Restore all default parameters	UDINT	RW	No	0x00000000 to 0xFFFFFFFF (Default: 0x00000001)	No
	2	Restore communication default parameters	UDINT	RW	No	0x00000000 to 0xFFFFFFFF (Default: 0x00000001)	No
	3	Restore application default parameters	UDINT	RW	No	0x00000000 to 0xFFFFFFFF (Default: 0x00000001)	No
	4	Restore manufacturer defined default parameters	UDINT	RW	No	0x00000000 to 0xFFFFFFFF (Default: 0x00000001)	No

By reading data of an object entry, the SERVOPACK provides its capability to restore default parameters.

Bit	Value	Meaning
31	0	Last command completed: No errors
	1	Last command completed: Error
1 to 30	0	Reserved
0	0	SERVOPACK does not restore default parameter settings.
	1	SERVOPACK restores default parameter settings.

In order to avoid restoring of parameters by mistake, restoring is only executed when a specific signature is written to the appropriate subindex. The signature that shall be written is “load.”

Signature	MSB			LSB
ASCII	d	a	o	l
hex	64h	61h	6Fh	6Ch

By writing “load” to Subindex 1, all default parameter values are restored.

By writing “load” to Subindex 2, the default values of communication parameters (Object 1xxxh) are restored.

By writing “load” to Subindex 3, the default values of application parameters (Object 23xxh and 6xxxh) are restored.

By writing “load” to Subindex 4, the default values of SERVOPACK parameters (Object 2000h to 22FFh) are restored.

- Note 1. If a wrong signature is written, the SERVOPACK refuses to restore and responds with Abort SDO Transfer.
 2. Subindex 1 and Subindex 4 can be written only in Switch on Disabled state (Servo off state).
 3. If the restoring parameters are executing, 0 will be returned by read this object.
 4. The default values are set as valid after the SERVOPACK has been reset or power cycled.

(7) Identity Object (1018h)

The object contains general information about the device.

Index	Sub	Name	Data Type	Access	PDO Mapping	Value	EEPROM
1018h	0	Number of entries	USINT	RO	No	4	No
	1	Vendor ID	UDINT	RO	No	0x00000539	No
	2	Product code *1	UDINT	RO	No	0x02200201 0x02200202 *1	No
	3	Revision number *2	UDINT	RO	No	–	No
	4	Serial number *3	UDINT	RO	No	0x00000000	No

*1. SERVOPACK for one axis (CACR-JU□□□□CA): 0x02200201
SERVOPACK for two axes (CACR-JUM□□□□CA): 0x02200202

*2. The revision number is stored as follows:

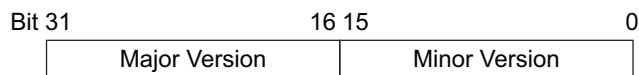

The major version identifies a specific CANopen over EtherCAT (CoE) behavior. If the CoE functionality is expanded, the major version has to be increased. The minor version number identifies different versions with the same behavior.

*3. Serial number is not used. (always 0)

4.3 PDO Mapping Objects

The CANopen over EtherCAT protocol allows the user to map objects into Process Data Objects (PDOs) to use these PDOs for real time data transfer.

PDO Mapping configuration defines which objects in a PDO will include.

Each Mapping entry (subindex 1 to 16) is defined as follows.

Bit 31	16 15	8 7	0
Object index	Subindex	Length	

Bit 0-7: Length of the mapped objects in bits (for a gap in a PDO: shall have the bit length of the gap)

Bit 8-15: Subindex of the mapped object (0 in case of a gap in a PDO)

Bit 16-31: Index of the mapped object (for a gap in a PDO: shall be zero)

Supplement Information

PDO mapping objects can be changed only in the EtherCAT Pre-Operational state.

Mapping entries (subindex 1 - 16) has to be set after subindex 0 was written to 0.

(1) Receive PDO Mapping (1600h)

Index	Sub	Name	Data Type	Access	PDO Mapping	Value	EEPROM
1600h	0	Number of objects in this PDO	USINT	RW	No	0 to 16 (Default: 6)	Yes
	1	Mapping entry 1	UDINT	RW	No	0 to 0xFFFFFFFF (Default: 0x60400010)	Yes
	2	Mapping entry 2	UDINT	RW	No	0 to 0xFFFFFFFF (Default: 0x607A0020)	Yes
	3	Mapping entry 3	UDINT	RW	No	0 to 0xFFFFFFFF (Default: 0x60B10020)	Yes
	4	Mapping entry 4	UDINT	RW	No	0 to 0xFFFFFFFF (Default: 0x60B20010)	Yes
	5	Mapping entry 5	UDINT	RW	No	0 to 0xFFFFFFFF (Default: 0x60B80010)	Yes
	6	Mapping entry 6	UDINT	RW	No	0 to 0xFFFFFFFF (Default: 0x23C80110)	Yes
	7	Mapping entry 7	UDINT	RW	No	0 to 0xFFFFFFFF (Default: 0)	Yes
	8	Mapping entry 8	UDINT	RW	No	0 to 0xFFFFFFFF (Default: 0)	Yes
	9	Mapping entry 9	UDINT	RW	No	0 to 0xFFFFFFFF (Default: 0)	Yes
	10	Mapping entry 10	UDINT	RW	No	0 to 0xFFFFFFFF (Default: 0)	Yes
	11	Mapping entry 11	UDINT	RW	No	0 to 0xFFFFFFFF (Default: 0)	Yes
	12	Mapping entry 12	UDINT	RW	No	0 to 0xFFFFFFFF (Default: 0)	Yes
	13	Mapping entry 13	UDINT	RW	No	0 to 0xFFFFFFFF (Default: 0)	Yes
	14	Mapping entry 14	UDINT	RW	No	0 to 0xFFFFFFFF (Default: 0)	Yes
	15	Mapping entry 15	UDINT	RW	No	0 to 0xFFFFFFFF (Default: 0)	Yes
16	Mapping entry 16	UDINT	RW	No	0 to 0xFFFFFFFF (Default: 0)	Yes	

(2) Transmit PDO Mapping (1A00h)

Index	Sub	Name	Data Type	Access	PDO Mapping	Value	EEPROM
1A00h	0	Number of objects in this PDO	USINT	RW	No	0 to 16 (Default: 7)	Yes
	1	Mapping entry 1	UDINT	RW	No	0 to 0xFFFFFFFF (Default: 0x60410010)	Yes
	2	Mapping entry 2	UDINT	RW	No	0 to 0xFFFFFFFF (Default: 0x60640020)	Yes
	3	Mapping entry 3	UDINT	RW	No	0 to 0xFFFFFFFF (Default: 0x606C0020)	Yes
	4	Mapping entry 4	UDINT	RW	No	0 to 0xFFFFFFFF (Default: 0x60770010)	Yes
	5	Mapping entry 5	UDINT	RW	No	0 to 0xFFFFFFFF (Default: 0x60B90010)	Yes
	6	Mapping entry 6	UDINT	RW	No	0 to 0xFFFFFFFF (Default: 0x60BA0020)	Yes
	7	Mapping entry 7	UDINT	RW	No	0 to 0xFFFFFFFF (Default: 0x23C80210)	Yes
	8	Mapping entry 8	UDINT	RW	No	0 to 0xFFFFFFFF (Default: 0)	Yes
	9	Mapping entry 9	UDINT	RW	No	0 to 0xFFFFFFFF (Default: 0)	Yes
	10	Mapping entry 10	UDINT	RW	No	0 to 0xFFFFFFFF (Default: 0)	Yes
	11	Mapping entry 11	UDINT	RW	No	0 to 0xFFFFFFFF (Default: 0)	Yes
	12	Mapping entry 12	UDINT	RW	No	0 to 0xFFFFFFFF (Default: 0)	Yes
	13	Mapping entry 13	UDINT	RW	No	0 to 0xFFFFFFFF (Default: 0)	Yes
	14	Mapping entry 14	UDINT	RW	No	0 to 0xFFFFFFFF (Default: 0)	Yes
	15	Mapping entry 15	UDINT	RW	No	0 to 0xFFFFFFFF (Default: 0)	Yes
16	Mapping entry 16	UDINT	RW	No	0 to 0xFFFFFFFF (Default: 0)	Yes	

4.4 Sync Manager Communication Objects

(1) Sync Manager Communication Type (1C00h)

Index	Sub	Name	Data Type	Access	PDO Mapping	Value	EEPROM
1C00h	0	Number of used Sync Manager channels	USINT	RO	No	4	No
	1	Communication type sync manager 0	USINT	RO	No	1: mailbox receive (Master to slave)	No
	2	Communication type sync manager 1	USINT	RO	No	2: mailbox send (Slave to master)	No
	3	Communication type sync manager 2	USINT	RO	No	3: process data output (Master to slave)	No
	4	Communication type sync manager 3	USINT	RO	No	4: process data input (Slave to master)	No

(2) Sync Manager PDO Assignment (1C10h to 1C13h)

Sync Manager PDO Assignment configuration defines which PDOs will be transferred for the process data communication.

Index	Sub	Name	Data Type	Access	PDO Mapping	Value	EEPROM
1C10h	0	Sync Manager PDO assignment 0	USINT	RO	No	0	No
1C11h	0	Sync Manager PDO assignment 1	USINT	RO	No	0	No
1C12h	0	Number of assigned PDOs	USINT	RW	No	0 to 2 (Default: 1 or 2*)	Yes
	1	PDO Mapping object index of assigned RxPDO 1	UINT	RW	No	1600h, 1610h (Default: 1600h)	Yes
	2	PDO Mapping object index of assigned RxPDO 2	UINT	RW	No	1600h, 1610h (Default: 1610h)	Yes
1C13h	0	Number of assigned PDOs	USINT	RW	No	0 to 2 (Default: 1 or 2*)	Yes
	1	PDO Mapping object index of assigned TxPDO 1	UINT	RW	No	1A00h, 1A10h (Default: 1A00h)	Yes
	2	PDO Mapping object index of assigned TxPDO 2	UINT	RW	No	1A00h, 1A10h (Default: 1A10h)	Yes

* SERVOPACK for one axis: 1
SERVOPACK for two axes: 2

The object 1C12h/1C13h can be changed only in the EtherCAT Pre-Operational state.
Subindex 1 or 2 has to be set after subindex 0 was written to 0.

(3) Sync Manager Synchronization (1C32h, 1C33h)

■ Sync Manager 2 (Process Data Output) Synchronization

Index	Sub	Name	Data Type	Access	PDO Mapping	Value	EEPROM
1C32h	0	Number of Synchronization Parameters	USINT	RO	No	12	No
	1	Synchronization type	UINT	RO	No	0: Free-Run (DC unused) 2: DC Sync0 (DC used)	No
	2	Cycle time	UDINT	RO	No	Time between Sync0 events [ns]	No
	3	Shift time	UDINT	RO	No	125000 [ns]	No
	4	Synchronization types supported	UINT	RO	No	Bit 0 = 1: Free-Run supported Bit 4:2 = 001: DC Sync0 supported Bit 6:5 = 00: No Output Shift supported	No
	5	Minimum cycle time	UDINT	RO	No	250000 [ns]	No
	6	Calc and copy time	UDINT	RO	No	62500 [ns]	No
	7	Reserved	UDINT	RO	No	–	No
	8	Reserved	UINT	RO	No	–	No
	9	Delay time	UDINT	RO	No	125000 [ns]	No
	10	Sync0 cycle time	UDINT	RO	No	same as 1C32h:02	No
	11	Reserved	UDINT	RO	No	–	No
12	SM2 event miss count	UDINT	RO	No	–	No	

■ Sync Manager 3 (Process Data Input) Synchronization

Index	Sub	Name	Data Type	Access	PDO Mapping	Value	EEPROM
1C33h	0	Number of Synchronization Parameters	USINT	RO	No	10	No
	1	Synchronization type	UINT	RO	No	same as 1C32:01	No
	2	Cycle time	UDINT	RO	No	same as 1C32:02	No
	3	Shift time	UDINT	RW	No	125000 + 250000*n [ns] (n = 1, 2, 3...) Range: 0 to (Sync0 event cycle time – 125000)	Yes
	4	Synchronization types supported	UINT	RO	No	Bit 0 = 1: Free-Run supported Bit 4:2 = 001: DC Sync0 supported Bit 6:5 = 01: Input Shift with local timer supported	No
	5	Minimum cycle time	UDINT	RO	No	same as 1C32h:05	No
	6	Calc and copy time	UDINT	RO	No	62500 [ns]	No
	7	Reserved	UDINT	RO	No	–	No
	8	Reserved	UINT	RO	No	–	No
	9	Delay time	UDINT	RO	No	125000 [ns]	No
	10	Sync0 cycle time	UDINT	RO	No	same as 1C32h:10	No

(4) Sync Error Setting (10F1h)

Index	Sub	Name	Data Type	Access	PDO Mapping	Value	EEPROM
10F1h	0	Number of entries	USINT	RO	No	2	No
	1	Reserved	UDINT	RO	No	0	No
	2	Sync Error Count Limit	UDINT	RW	No	0 to 15 (Default: 9)	Yes

■ 0x10F1:2 Sync Error Count Limit

This object defines the tolerable level of failure when receiving the process data. If the value of the Internal Error Counter in the SERVOPACK exceeds the value of this object, the SERVOPACK will issue an alarm (A12h) and change the ESM state to SAFEOP.

The Internal Error Counter is incremented by 3 if the process output data is not updated (the Receive (SM2) event does not occur) at Sync0 event. When the process output data is normally updated, the Internal Error Counter is decremented by 1. The Internal Error Counter is reset when the ESM state is transited to OP from SAFEOP.

An example of Internal Error Counter is shown below.

Receive (SM2) Event	1	0	1	0	1	0	1	0	1	0	1
SERVOPACK Internal Error Counter (Error Counter Limit = 9)	0	3	2	5	4	7	6	9 (error)	9	9	9

In this example, a failure in receiving the process data repeats in each DC (Sync0) cycle. After 8 DC cycles, the internal error count reaches the Sync Error Count Limit, and the SERVOPACK issued an alarm.

No alarm will be detected when the DC mode is disabled and/or when the Sync error count limit is set to 0.

4.5 Manufacturer Specific Objects

Supplemental Information

The index numbers for a SERVOPACK for one axis and axis 1 of a SERVOPACK for two axes are given for the index numbers of the servo parameters. The index numbers for axis 2 of a SERVOPACK for two axes can be calculated by adding 400 hex to the index numbers for axis 1.

Example:

Parameter number: Pn100

= Index number for axis 1: 2040h

↓ Add 400 hex to calculate the index number for axis 2.

= Index number for axis 2: 2440h

(1) SERVOPACK Parameters (2000h-22FFh)

Object 2000h to 22FFh are mapped to SERVOPACK parameters (Pnxxx).

(2) User Parameter Configuration (2300h)

This object enables all User parameter settings, and initializes the all position values.

Index	Sub	Name	Data Type	Access	PDO Mapping	Value	EEPROM
2300h	0	User Parameter Configuration	UDINT	RW	No	0 to 0xFFFFFFFF (Default: 0)	No

Before restarting operation without turning the power supply OFF and then ON again after having changed the following objects, this object must be executed to enable new settings.

- Object 2301h, 2302h and 2303h
- SERVOPACK parameters which need power on reset.

■ Procedure

1. Change the drive state to “Switch on Disabled.”
2. Set new parameter setting value.
3. Set object 2300h to 1 for activating the “new” user settings.

When processing is completed, the value of object 2300h is reset to 0.

(3) Position User Unit (2301h)

This object sets the user defined position reference unit [Pos unit].

The user defined position reference unit is calculated by the following formula:

$$1 \text{ [Pos unit]} = (\text{Numerator}/\text{Denominator}) \text{ [inc]}$$

Index	Sub	Name	Data Type	Access	PDO Mapping	Value	EEPROM
2301h	0	Number of entries	USINT	RO	No	2	No
	1	Numerator	UDINT	RW	No	1 to 1073741823 (Default: 1)	Yes
	2	Denominator	UDINT	RW	No	1 to 1073741823 (Default: 1)	Yes

Available value range: $1/4096 < \text{Numerator} / \text{Denominator} < 4096$
(Alarm “A.A20” is detected when the setting value exceeds it.)

(4) Velocity User Unit (2302h)

This object sets the user defined velocity reference unit [Vel unit].

The user defined velocity reference unit is calculated by the following formula:

$$1 \text{ [Vel unit]} = (\text{Numerator} / \text{Denominator}) \text{ [inc/sec]}$$

Index	Sub	Name	Data Type	Access	PDO Mapping	Value	EEPROM
2302h	0	Number of entries	USINT	RO	No	2	No
	1	Numerator	UDINT	RW	No	1 to 1073741823 (Default: 1)	Yes
	2	Denominator	UDINT	RW	No	1 to 1073741823 (Default: 1)	Yes

Available value range: $1/128 \leq \text{Numerator} / \text{Denominator} \leq 524288$

(Alarm "A.A20" is detected when the setting value exceeds it.)

(5) Acceleration User Unit (2303h)

This object sets the user defined acceleration reference unit [Acc unit].

The user defined acceleration reference unit is calculated by the following formula:

$$1 \text{ [Acc unit]} = (\text{Numerator} / \text{Denominator}) \times 10^4 \text{ [inc/sec}^2\text{]}$$

Index	Sub	Name	Data Type	Access	PDO Mapping	Value	EEPROM
2303h	0	Number of entries	USINT	RO	No	2	No
	1	Numerator	UDINT	RW	No	1 to 1073741823 (Default: 1)	Yes
	2	Denominator	UDINT	RW	No	1 to 1073741823 (Default: 1)	Yes

Available value range: $1/128 \leq \text{Numerator} / \text{Denominator} \leq 16384$

(Alarm "A.A20" is detected when the setting value exceeds it.)

(6) Usage of User Units

The setting methods of user defined reference units are explained by using the following two cases as examples.

- Case 1: Linear mechanism system with ball screw
- Case 2: Rotary mechanism system with rotary table

■ Case 1: Linear Mechanism System with Ball Screw

• User Requirements and Application Assumptions

- User defined position reference unit: 0.001 mm
- User defined velocity reference unit: 0.1 mm/s
- User defined acceleration reference unit: 0.1 mm/s²
- Application assumption data
 - Encoder resolution: 20 bits (1048576 inc)
 - Ball screw pitch: 6 mm
 - Deceleration ratio: 2/1 (load shaft will rotate once for each time the motor shaft rotates twice.)

• Settings

• Position User Unit (2301h)

The number of encoder pulses for each user defined position reference unit:

$$\begin{aligned} & \frac{(\text{Encoder resolution} \times \text{Deceleration ratio} [\text{inc}])}{\text{Movement amount per one rotation of load shaft} [\text{Pos unit}]} \\ &= \frac{1048576 [\text{inc}] \times (2/1)}{6 [\text{mm}] / 0.001 [\text{mm}]} \\ &= \frac{2097152}{6000} [\text{inc}] \end{aligned}$$

Therefore, the object is set as follows.

Object 2301h:01 (Nominator) = 2097152

Object 2301h:02 (Denominator) = 6000

• Velocity User Unit (2302h)

By converting one user defined velocity reference unit [0.1 mm/s] into [inc/s]:

$$\begin{aligned} & 1 [\text{Vel unit}] \\ &= \frac{1048576 [\text{inc}] \times (2/1)}{6 [\text{mm}]} \times 0.1 [\text{mm/s}] \\ &= \frac{2097152}{60} [\text{inc/s}] \end{aligned}$$

Therefore, the object is set as follows.

Object 2302h:01 (Nominator) = 2097152

Object 2302h:02 (Denominator) = 60

• Acceleration User Unit (2303h)

By converting one user defined acceleration reference unit [0.1 mm/s²] into [10⁴ inc/s²]

$$\begin{aligned} & 1 [\text{Acc unit}] \\ &= \frac{1048576 [\text{inc}] \times (2/1)}{6 [\text{mm}]} \times 0.1 [\text{mm/s}^2] \times 10^{-4} \\ &= \frac{2097152}{6 \times 10^5} [10^4 \text{ inc/s}^2] \end{aligned}$$

Therefore, the object is set as follows.

Object 2303h:01 (Nominator) = 2097152

Object 2303h:02 (Denominator) = 600000

■ Case 2: Rotary Mechanism System with Rotary Table

• User Requirements and Application Assumptions

- User defined position reference unit: 0.001 deg
- User defined velocity reference unit: 1 deg/s
- User defined acceleration reference unit: 1 deg/s²
- Application assumption data
 - Encoder: 20 bits (1048576 inc)
 - Degree of rotary table movement for each rotation of the load shaft: 360 deg
 - Deceleration ratio: 3/1 (one load shaft rotation per three motor shaft rotations)

• Setting

• Position User Unit (2301h)

Number of encoder increments per one user defined position reference unit:

$$\begin{aligned} & \frac{(\text{Encoder resolution} \times \text{Deceleration ratio} [\text{inc}])}{\text{Movement amount per one rotation of load shaft} [\text{Pos unit}]} \\ &= \frac{1048576 [\text{inc}] \times (3/1)}{360 [\text{deg}]/0.001 [\text{deg}]} \\ &= \frac{3145728}{360000} [\text{inc}] \end{aligned}$$

Therefore, the object is set as follows.

Object 2301h:01 (Nominator) = 3145728

Object 2301h:02 (Denominator) = 360000

• Velocity User Unit (2302h)

By converting one user defined velocity reference unit [1 deg/s] into [inc/s],

$$\begin{aligned} & 1 [\text{Vel unit}] \\ &= \frac{1048576 [\text{inc}] \times (3/1)}{360 [\text{deg}]} \times 1 [\text{deg/s}] \\ &= \frac{3145728}{360} [\text{inc/s}] \end{aligned}$$

Therefore, the object is set as follows.

Object 2302h:01 (Nominator) = 3145728

Object 2302h:02 (Denominator) = 360

• Acceleration User Unit (2303h)

By converting one user defined acceleration reference unit [1 deg/s²] to [10⁴ inc/s²],

$$\begin{aligned} & 1 [\text{Acc unit}] \\ &= \frac{1048576 [\text{inc}] \times (3/1)}{360 [\text{deg}]} \times 1 [\text{deg/s}^2] \times 10^4 \\ &= \frac{3145728}{360 \times 10^4} [10^4 \text{ inc/s}^2] \end{aligned}$$

Therefore, the object is set as follows.

Object 2303h:01 (Nominator) = 3145728

Object 2303h:02 (Denominator) = 3600000

(7) SERVOPACK Adjusting Command (2310h)

This object should be used for SERVOPACK adjusting services (e.g., Encoder setup, Multi-turn reset and so on). Writes the data into the subindex 1 to start the command execution. Also, reads the subindex 3 to accept the response. If the response is not available when reading subindex 3, the first byte of the reply data could give information about the progress.

Index	Sub	Name	Data Type	Access	PDO Mapping	Value	EEPROM
2310h	0	Number of entries	USINT	RO	No	3	No
	1	Command	STRING [16]	RW	No	Byte 0 to n: Service Request Data A write access to the command data will execute the command	No
	2	Status	USINT	RO	No	0: last command completed, no errors, no response data 1: last command completed, no errors, with response data 2: last command completed, error, no response data 3: last command completed, error, with response data 255: command is executing	No
	3	Reply	STRING [16]	RO	No	Byte 0: as subindex 2 Byte 1: unused 2 to n: Service Response Data	No

■ Command/Reply data format

Command data (Service Request data)	
Byte	Description
0	Reserved
1	Reserved
2	CCMD (Command code) 00: Read request 01: Write request
3	CSIZE (CDATA length in byte)
4 to 7	CADDRESS (Address)
8 to 15	CDATA (Writing data)

Reply data (Service Response data)	
Byte	Description
0	Status (As subindex 2)
1	Reserved
2	RCMD (Echo back of CCMD)
3	RSIZE (R_DATA length in byte)
4 to 7	RADDRESS (Echo back of CADDRESS)
8 to 15	RDATA (Read data) /ERROCODE

■ Executable Adjustments

Adjustment	Request Code	Preparation before execution	Processing Time	Execution Conditions
Absolute encoder reset	1008H	Required	5 s max.	When using an incremental encoder, impossible to reset the encoder while the servo is ON.
Automatic offset adjustment of motor current detection signals	100EH	None	5 s max.	Adjustment is disabled: <ul style="list-style-type: none"> • While the main circuit power supply is OFF • While the servo is ON • While the servomotor is running
Multiturn limit setting	1013H	Required	5 s max.	When using an incremental encoder, the setting is disabled unless A.CC0 (Multiturn limit disagreement) occurs.

■ How to Send a Command for Adjustment

1. Send the following data and set the request code of the adjustment to be executed.

CCMD = 0001H

CADDRESS = 2000H

CSIZE = 0002H

CDATA = Request code of the adjustment to be executed

When the slave station receives the command normally, status field will be returned to 1.

If an error occurs, carry out the operation in step 4 to abort execution.

2. For adjustment that requires a preparation process, send the following data.

If the preparation before execution is not required, carry out the operation in step 3.

CCMD = 0001H

CADDRESS = 2001H

CSIZE = 0002H

CDATA = 0002H

When the slave station receives the command normally, status field will be returned to 1.

If an error occurs, carry out the operation in step 4 to abort execution.

3. Send the following data to execute adjustment.

CCMD = 0001H

CADDRESS = 2001H

CSIZE = 0002H

CDATA = 0001H

When the slave station receives the command normally, status field will be returned to 1.

If an error occurs, carry out the operation in step 4 to abort execution.

4. Send the following data to abort the execution.

CCMD = 0001H

CADDRESS = 2000H

CSIZE = 0002H

CDATA = 0000H

When the slave station receives the command normally, status field will be returned to 1.

Note: If no command can be received in 10 seconds after step1, adjustment operation will be automatically aborted.

4.6 Machine Tools Object (23C8h)

Index	Sub	Name	Data Type	Access	PDO Mapping	Value	EEPROM
23C8h	0	Number of entries	USINT	RO	No	3	No
	1	Machine tool function	UINT	RW	Yes	0 to 0xFFFF (Default: 0)	No
	2	Machine tool status	UINT	RO	Yes	0 to 0xFFFF (Default: 0)	No
	3	Load meter	INT	RO	Yes	0 to 0xFFFF (Default: 0)	No

■ Machine tool function bit

Bit	Status	Description
0 to 3	G-sel	Use to view the settings for the speed loop gain, position loop gain, speed loop integral time constant, and 1st step 1st torque reference filter time constant.
4 to 5	Op-mod	Use to select the axis operation mode.
6 to 12	–	Reserved
13	Sv-mod	Enable or disable servo mode when using an induction motor. 0: Disabled 1: Enabled
14	Mc-on	Use to control the main circuit contactor ON output signal of the power regeneration converter.
15	Wnd-chg	Use to select the type of winding to be used. 0: High-speed winding 1: Low-speed winding

■ Machine tool status bit

Bit	Status	Description
0 to 13	–	Reserved
14	E-stop2	Use to monitor the status of emergency stop signal 2 from the converter.
15	Wnd-mod	Use to monitor the winding used. 0: High-speed winding 1: Low-speed winding

4.7 Device Control

(1) Error Code (603Fh)

This provides the SERVOPACK's alarm/warning code of the last error which occurred in device.

Index	Sub	Name	Data Type	Access	PDO Mapping	Value	EEPROM
603Fh	0	Error Code	UINT	RO	Yes	0	No

(2) Controlword (6040h)

The Controlword consists of bits for the controlling of the drive state, the controlling of operating modes and manufacturer specific options.

Index	Sub	Name	Data Type	Access	PDO Mapping	Value	EEPROM
6040h	0	Controlword	UINT	RW	Yes	0 to 0xFFFF (Default: 0)	No

■ Controlword Bits

Bit No	Function	Description
0	Switch on	See <Details on Bits 0 to 3>.
1	Enable voltage	
2	Quick stop	
3	Enable operation	
4 to 6	Operation mode specific	See <Details on Bits 4 to 9>.
7	Fault reset	0 → 1: Alarm/Warning reset
8	Halt	See <Details on Bits 4 to 9>.
9	Operation mode specific	
10	– (Reserved)	–
11	Positive Torque Limit	0: Torque Limit parameter (Object 20A3h:1) not activated 1: Torque Limit parameter (Object 20A3h:1) activated
12	Negative Torque Limit	0: Torque Limit parameter (Object 20A3h:2) not activated 1: Torque Limit parameter (Object 20A3h:2) activated
13 to 15	– (Reserved)	–

<Details on Bits 0 to 3>

- Bit 0 to 3: for the controlling command of the drive state

Command	Bit of the Controlword				
	Bit7	Bit3	Bit2	Bit1	Bit0
Shutdown	0	–	1	1	0
Switch on	0	0	1	1	1
Switch on + Enable operation	0	1	1	1	1
Disable voltage	0	–	–	0	–
Quick stop	0	–	0	1	–
Disable operation	0	0	1	1	1
Enable operation	0	1	1	1	1

<Details on Bits 4 to 9>

- Bit 4, 5 and 9: for the controlling of Profile position mode

Bit9	Bit5	Bit4	Definition
0	0	0 → 1	Start the next positioning after the current positioning completes (target reached)
–	1	0 → 1	Start the next positioning immediately
1	0	0 → 1	Positioning with current profile velocity up to the current set-point is proceeded and then next positioning will be applied.

- Bit 6 and 8: for the controlling of Profile position mode

Bit	Function	Value	Definition
6	Abs/rel	0	Target position is an absolute value.
		1	Target position is a relative value.
8	Halt	0	Positioning is executed or continued.
		1	Stop axis according to halt option code (605Dh)

- Bit 4, 5, 6, 8 and 9: for the controlling of Homing mode

Bit	Function	Value	Definition
4	Homing operation start	0	Do not start homing procedure
		1	Start or continue homing procedure
5	–	0	Reserved
6	–	0	Reserved
8	Halt	0	Enable bit 4
		1	Stop axis according to halt option code (605Dh)
9	–	0	Reserved

- Bit 4, 5, 6, 8 and 9: for the controlling of Cyclic synchronous position/velocity/torque mode

Bit	Function	Value	Definition
4	–	0	Reserved
5	–	0	Reserved
6	–	0	Reserved
8	Halt	0	The motion is executed or continued.
		1	Stop axis according to halt option code (605Dh)
9	–	0	Reserved

- Bit 4, 5, 6, 8 and 9: for the controlling of Interpolated position mode

Bit	Function	Value	Definition
4	Enable interpolation	0	Disable interpolation
		1	Enable interpolation
5	–	0	Reserved
6	–	0	Reserved
8	Halt	0	Execute instruction of bit 4
		1	Stop axis according to halt option code (605Dh)
9	–	0	Reserved

- Bit 4, 5, 6, 8 and 9: for the controlling of Profile velocity/torque mode

Bit	Function	Value	Definition
4	–	0	Reserved
5	–	0	Reserved
6	–	0	Reserved
8	Halt	0	The motion is executed or continued.
		1	Stop axis according to halt option code (605Dh)
9	–	0	Reserved

(3) Statusword (6041h)

The Statusword consist of bits for the current state of the drive and the operating state of the mode.

Index	Sub	Name	Data Type	Access	PDO Mapping	Value	EEPROM
6041h	0	Statusword	UINT	RO	Yes	0	No

■ Statusword Bits

Bit	Status	Description
0	Ready to switch on	See <Details on Bits 0 to 7>.
1	Switched on	
2	Operation enabled	
3	Fault	
4	Voltage enabled	
5	Quick stop	
6	Switch on disabled	
7	Warning	
8	Reserved	Reserved
9	Remote	Controlword (6040h) is processed.
10	Target reached	See <Details on Bits 10, 12, and 13>.
11	Internal limit active	See <Details on Bit 11>.
12, 13	Operation mode specific	See <Details on Bits 10, 12, and 13>.
14	Torque limit active	0: Torque limit activated 1: Torque limit not activated
15	HWBB active	0: HWBB activated 1: HWBB not activated

<Details on Bits 0 to 7>

- Bit 0 to 7: for the current state of the drive

Bit7	Bit6	Bit5	Bit4	Bit3	Bit2	Bit1	Bit0	Drive State
–	0	–	–	0	0	0	0	Not ready to switch on
–	1	–	–	0	0	0	0	Switch on disabled
–	0	1	–	0	0	0	1	Ready to switch on
–	0	1	–	0	0	1	1	Switched on
–	0	1	–	0	1	1	1	Operation enabled
–	0	0	–	0	1	1	1	Quick stop active
–	0	–	–	1	1	1	1	Fault reaction active
–	0	–	–	1	0	0	0	Fault
–	–	–	1	–	–	–	–	Main Power On
1	–	–	–	–	–	–	–	Warning is occurred

<Details on Bit 11>

- Bit11: Internal limit active

The internal limit is active in the following cases:

- Target position was limited with Software position limits
- N-OT / P-OT signals were activated
- Over Interpolation speed (only for Interpolated position and cyclic position mode)

If the reference speed of interpolation exceeds the following speed range, the target position will be ignored.

$$\frac{(\text{Target position} - \text{position demand value}) \times (2301\text{h}:01)/(2301\text{h}:02)}{\text{Interpolation time period}} < 4194304 \text{ [inc/ms]}$$

<Details on Bits 10, 12, and 13>

- Bit 10, 12, and 13: for Profile position mode

Bit No	Description	Value	Definition
10	Target reached	0	Halt (Bit 8 in Controlword) = 0: Target position not reached Halt (Bit 8 in Controlword) = 1: Axis decelerates
		1	Halt (Bit 8 in Controlword) = 0: Target position reached Halt (Bit 8 in Controlword) = 1: Velocity of axis is 0
12	Set-point acknowledge	0	Previous set-point already processed, waiting for new set-point
		1	Previous set-point still in process, set-point overwriting shall be accepted
13	Following error	0	No following error
		1	Following error

- Bit 10, 12, and 13: for Homing mode

Bit13	Bit12	Bit10	Definition
Homing error	Homing attained	Target reached	
0	0	0	Homing procedure is in progress
0	0	1	Homing procedure is interrupted or not started
0	1	0	Homing is attained, but target is not reached
0	1	1	Homing procedure is completed successfully
1	0	0	Homing error occurred, velocity is not 0
1	0	1	Homing error occurred, velocity is 0

- Bit 10, 12, and 13: for Cyclic synchronous position, velocity and torque mode

Bit	Status	Value	Definition
10	Target reached	0	Target (position/velocity/torque) not (yet) reached
		1	Target (position/velocity/torque) reached
12	Target value ignored	0	Target value (position/velocity/torque) ignored
		1	Target value shall be used as input to position control loop
13	Following error	0	No following error (always 0 in cyclic velocity and torque mode)
		1	Following error

- Bit 10, 12, and 13: for Interpolated position mode

Bit	Status	Value	Definition
10	Target reached	0	Halt (Bit 8 in Controlword) = 0: Target position not reached Halt (Bit 8 in Controlword) = 1: Axis decelerates
		1	Halt (Bit 8 in Controlword) = 0: Target position reached Halt (Bit 8 in Controlword) = 1: Velocity of axis is 0
12	Ip mode active	0	Interpolation not activated
		1	Interpolation activated
13	–	0	Reserved

- Bit 10, 12, and 13: for Profile velocity mode

Bit	Status	Value	Definition
10	Target reached	0	Halt (Bit 8 in Controlword) = 0: Target not reached Halt (Bit 8 in Controlword) = 1: Axis decelerates
		1	Halt (Bit 8 in Controlword) = 0: Target reached Halt (Bit 8 in Controlword) = 1: Velocity of axis is 0
12	Speed	0	Speed is not equal 0
		1	Speed is equal 0
13	–	0	Reserved

- Bit 10, 12, and 13: for Profile torque mode

Bit	Status	Value	Definition
10	Target reached	0	Halt (Bit 8 in Controlword) = 0: Target torque not reached Halt (Bit 8 in Controlword) = 1: Axis decelerates
		1	Halt (Bit 8 in Controlword) = 0: Target torque reached Halt (Bit 8 in Controlword) = 1: Velocity of axis is 0
12	–	0	Reserved
13	–	0	Reserved

(4) Quick Stop Option Code (605Ah)

The parameter quick stop option code determines what action should be taken if the Quick Stop function is executed.

Index	Sub	Name	Data Type	Access	PDO Mapping	Value	EEPROM
605Ah	0	Quick Stop Option Code	INT	RW	No	0 to 4 (Default: 2)	Yes

■ Data Description

Value	Data Description
0	Disable drive function (transit into Switch On Disabled).
1	Slow down on slow down ramp and transit into Switch On Disabled.*1, *2
2	Slow down on quick stop ramp and transit into Switch On Disabled.*1, *3
3	Slow down on the torque limit and transit into Switch On Disabled.*1

*1. The drive always stops by option code 0 (switch-off the drive power stage) in Profile Torque and Cyclic Torque mode.

*2. The slow down deceleration is defined as the following object.

- Profile Position, Interpolated Position, Cyclic Position, Cyclic Velocity mode: Object 6084h
- Homing mode : Object 609Ah

*3. The Quick stop deceleration (Object 6085h) value is used as quick stop ramp in any mode.

(5) Shutdown Option Code (605Bh)

The parameter determines what action is performed if there is a transition from Operation Enable state to Ready to Switch On state.

Index	Sub	Name	Data Type	Access	PDO Mapping	Value	EEPROM
605Bh	0	Shutdown Option Code	INT	RW	No	0 to 1 (Default: 0)	Yes

■ Data Description

Value	Data Description
0	Disable drive function (transit into Switch On Disabled).
1	Slow down on slow down ramp and transit into Switch On Disabled.*1, *2

- *1. The drive always stops by option code 0 (switch-off the drive power stage) in Profile Torque and Cyclic Torque mode.
- *2. The slow down deceleration is defined as the following object.
 - Profile Position, Interpolated Position, Cyclic Position, Cyclic Velocity mode: Object 6084h
 - Homing mode : Object 609Ah

(6) Disable Operation Option Code (605Ch)

The parameter determines what action is performed if there is a transition from Operation Enable state to Switched On state.

Index	Sub	Name	Data Type	Access	PDO Mapping	Value	EEPROM
605Ch	0	Disable Operation Option Code	INT	RW	No	0 to 1 (Default: 1)	Yes

■ Data Description

Value	Data Description
0	Disable drive function (transit into Switch On Disabled).
1	Slow down on slow down ramp and transit into Switch On Disabled.*1, *2

- *1. The drive always stops by option code 0 (switch-off the drive power stage) in Profile Torque and Cyclic Torque mode.
- *2. The slow down deceleration is defined as the following object.
 - Profile Position, Interpolated Position, Cyclic Position, Cyclic Velocity mode: Object 6084h
 - Homing mode : Object 609Ah

(7) Halt Option Code (605Dh)

The parameter halt option code determines what action should be taken if the bit 8 (halt) in the Controlword is active.

Index	Sub	Name	Data Type	Access	PDO Mapping	Value	EEPROM
605Dh	0	Halt Option Code	INT	RW	No	0 to 4 (Default: 1)	Yes

■ Data Description

Value	Data Description
1	Slow down on slow down ramp and stay in Operation Enabled.*1,*2
2	Slow down on quick stop ramp and stay in Operation Enabled.*1,*3
3	Slow down on the torque limit and stay in Operation Enabled.*1

*1. If the halt is active in Profile Torque and Cyclic Torque mode, the torque demand value is down to zero.

*2. The slow down deceleration is defined as the following object.

- Profile Position, Interpolated Position, Cyclic Position, Cyclic Velocity mode: Object 6084h
- Homing mode : Object 609Ah

*3. The Quick stop deceleration (Object 6085h) value is used as quick stop ramp in any mode.

(8) Fault Reaction Option Code (605Eh)

The parameter determines what action is performed when fault is detected in the drive system.

Index	Sub	Name	Data Type	Access	PDO Mapping	Value	EEPROM
605Eh	0	Fault Reaction Option Code	INT	RW	No	0	Yes

■ Data Description

Value	Data Description
0	Disable drive function, motor is free to rotate. (Turns the servo OFF.)

(9) Modes of Operation (6060h)

The master writes to the *modes of operation* object in order to select the operation mode. The drive device provides the *modes of operation display* object to indicate the actual activated operation mode.

Index	Sub	Name	Data Type	Access	PDO Mapping	Value	EEPROM
6060h	0	Modes of Operation	SINT	RW	Yes	0 to 10 (Default: 0)	Yes

■ Data Description

Value	Data Description
0	No mode change/no mode assigned
1	Profile Position mode
2	Reserved (keep last mode)
3	Profile Velocity mode
4	Torque Profile mode
6	Homing mode
7	Interpolated Position mode
8	Cyclic Sync Position mode
9	Cyclic Sync Velocity mode
10	Cyclic Sync Torque mode
Other	Reserved (keep last mode)

(10) Modes of Operation Display (6061h)

The modes of operation display show the current mode of operation.

The meaning of the returned value corresponds to that of the modes of operation option code (index 6060h).

Index	Sub	Name	Data Type	Access	PDO Mapping	Value	EEPROM
6061h	0	Modes of Operation Display	SINT	RO	Yes	0	No

(11) Supported Drive Modes (6502h)

This object gives an overview of the implemented operating modes in the device.

Index	Sub	Name	Data Type	Access	PDO Mapping	Value	EEPROM
6502h	0	Supported Drive Modes	UDINT	RO	No	03EDh	No

■ Data Description

Bit	Supported Modes	Definition
0	Pp (Profile Position mode)	1: Supported
1	Vl (Velocity mode)	0: Not supported
2	Pv (Profile Velocity mode)	1: Supported
3	Tq (Torque Profile mode)	1: Supported
4	Reserved	0
5	Hm (Homing mode)	1: Supported
6	Ip (Interpolated Position mode)	1: Supported
7	Csp (Cyclic Sync Position mode)	1: Supported
8	Csv (Cyclic Sync Velocity mode)	1: Supported
9	Cst (Cyclic Sync Torque mode)	1: Supported
10 to 31	Reserved	0

4.8 Profile Position Mode

(1) Target Position (607Ah)

This object is the target position in the Profile Position mode and Cyclic Synchronous Position mode.

In Profile Position mode, the value of this object is interpreted as either an absolute or relative value depending on the abs/rel flag of Controlword. In Cyclic Synchronous Position mode, it is always interpreted as an absolute value.

Index	Sub	Name	Data Type	Access	PDO Mapping	Value	EEPROM
607Ah	0	Target Position	DINT	RW	Yes	-2147483648 to +2147483647 (Default: 0) [Pos. unit]	No

(2) Software Position Limit (607Dh)

This object specifies the absolute position limit values for the position demand value. Every target position is checked against these limits.

The limit positions are specified in user defined position reference units, the same as for target position, and are always a relative value to the machine home position.

The limit values are corrected internally by the Home Offset as follows. The target positions are compared with the corrected values.

- Corrected min. position limit = min. position limit – home offset (Object 607Ch)
- Corrected max. position limit = max. position limit – home offset (Object 607Ch)

Software position limit is enabled at the following cases:

- Homing is completed.
- Absolute encoder is connected.

If the following setting, software limit is disabled:

- Min. position limit \geq Max. position limit

Index	Sub	Name	Data Type	Access	PDO Mapping	Value	EEPROM
607Dh	0	Number of entries	USINT	RO	No	2	No
	1	Min. position limit	DINT	RW	No	-536870912 to 536870911 (Default: 0) [Pos. unit]	Yes
	2	Max. position limit	DINT	RW	No	-536870912 to 536870911 (Default: 0) [Pos. unit]	Yes

(3) Max. Profile Velocity (607Fh)

The max. profile velocity is the maximum allowed speed in either direction during a profiled move.

Index	Sub	Name	Data Type	Access	PDO Mapping	Value	EEPROM
607Fh	0	Max. Profile Velocity	UDINT	RW	Yes	0 to 4294967295 (Default: 2147483647) [Vel. unit]	Yes

(4) Profile Velocity (6081h)

The profile velocity is the velocity normally attained at the end of the acceleration ramp during a profiled move and is valid for both directions of motion.

Index	Sub	Name	Data Type	Access	PDO Mapping	Value	EEPROM
6081h	0	Profile Velocity	UDINT	RW	Yes	0 to 4294967295 (Default: 0) [Vel. unit]	Yes

(5) Profile Acceleration (6083h)

This object specifies the acceleration for profile modes.

Index	Sub	Name	Data Type	Access	PDO Mapping	Value	EEPROM
6083h	0	Profile Acceleration	UDINT	RW	Yes	0 to 4294967295 (Default: 1000) [Acc. unit]	Yes

(6) Profile Deceleration (6084h)

This object specifies the deceleration for profile modes.

Index	Sub	Name	Data Type	Access	PDO Mapping	Value	EEPROM
6084h	0	Profile Deceleration	UDINT	RW	Yes	0 to 4294967295 (Default: 1000) [Acc. unit]	Yes

(7) Quick Stop Deceleration (6085h)

The quick stop deceleration is the deceleration used to stop the motor if the 'Quick Stop' command is given and the Quick Stop Option Code (see 605Ah) is set to 2.

Index	Sub	Name	Data Type	Access	PDO Mapping	Value	EEPROM
6085h	0	Quick Stop Deceleration	UDINT	RW	Yes	0 to 4294967295 (Default: 1000) [Acc. unit]	Yes

4.9 Homing Mode

(1) Home Offset (607Ch)

The home offset is the difference between the zero position for the application and the machine home position (found during homing).

Index	Sub	Name	Data Type	Access	PDO Mapping	Value	EEPROM
607Ch	0	Home Offset	DINT	RW	No	-536870912 to +536870911 (Default: 0) [Pos. unit]	Yes

- For Incremental Encoder

During the homing the machine home position is found and once the homing is completed the zero position is offset from the home position by adding the home offset to the home position.

- For Absolute Encoder

When an absolute encoder is connected to the SERVOPACK, the home offset is added to the encoder absolute position (the position actual value) in power up phase.

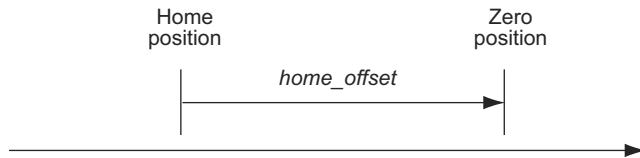

(2) Homing Method (6098h)

This object specifies the homing method. For details, refer to 3.4 *Homing*.

Index	Sub	Name	Data Type	Access	PDO Mapping	Value	EEPROM
6098h	0	Homing Method	SINT	RW	Yes	0 to 35 (Default: 35)	No

■ Data Description

Value (Method)	Data Description
0	No homing operation required
1	Homing on the negative limit switch and index pulse
2	Homing on the positive limit switch and index pulse
7 to 14	Homing on the home switch and index pulse
24	Homing on the home switch Same homing as Method 8 (without an index pulse)
28	Homing on the home switch Same homing as Method 12 (without an index pulse)
33, 34	Homing on index pulse
35	Homing on the current position

(3) Homing Speeds (6099h)

This object entries define the speeds used during homing and is given in user velocity units.

Index	Sub	Name	Data Type	Access	PDO Mapping	Value	EEPROM
6099h	0	Number of entries	USINT	RO	No	2	No
	1	Speed during search for switch	UDINT	RW	Yes	0 to 4294967295 (Default: 500000) [Vel. unit]	Yes
	2	Speed during search for zero	UDINT	RW	Yes	0 to 4294967295 (Default: 100000) [Vel. unit]	Yes

(4) Homing Acceleration (609Ah)

This object specifies the acceleration and deceleration for homing in user defined acceleration reference units.

Index	Sub	Name	Data Type	Access	PDO Mapping	Value	EEPROM
609Ah	0	Homing Acceleration	UDINT	RW	Yes	0 to 4294967295 (Default: 1000) [Acc. unit]	Yes

4.10 Position Control Function

(1) Position Demand Value (6062h)

This object provides the demanded position value in user position units.

Index	Sub	Name	Data Type	Access	PDO Mapping	Value	EEPROM
6062h	0	Position Demand Value	DINT	RO	Yes	– [Pos. unit]	No

(2) Position Actual Internal Value (6063h)

This object provides the current feedback position in encoder pulse units [inc].

Index	Sub	Name	Data Type	Access	PDO Mapping	Value	EEPROM
6063h	0	Position Actual Internal Value	DINT	RO	Yes	– [inc]	No

(3) Position Actual Value (6064h)

This object represents the actual value of the encoder position in defined user position units.

Index	Sub	Name	Data Type	Access	PDO Mapping	Value	EEPROM
6064h	0	Position Actual Value	DINT	RO	Yes	– [Pos. unit]	No

(4) Position Demand Internal Value (60FCh)

This object provides the output of the trajectory generator in position mode. This value is given in increments of the position encoder.

Index	Sub	Name	Data Type	Access	PDO Mapping	Value	EEPROM
60FCh	0	Position Demand Internal Value	DINT	RO	Yes	– [inc]	No

(5) Following Error Window (6065h)

This parameter specifies the accepted detection range for a Following error (bit 13 of Statusword).

If the actual value for the position is out of the allowable detection range and the set time in the Following Error Time Out (Object 6066h) has elapsed, the bit 13 of Statusword is set to 1 and a Following error may occur. A Following error may occur when a drive is blocked, unreachable profile velocity occurs, or at wrong closed-loop coefficients.

Index	Sub	Name	Data Type	Access	PDO Mapping	Value	EEPROM
6065h	0	Following Error Window	UDINT	RW	No	0 to 1073741823 (Default: 5242880) [Pos. unit]	Yes

(6) Following Error Time Out (6066h)

If the actual value for the position is out of the allowable detection range and the set time in the Following Error Time Out (Object 6066h) has elapsed, the bit 13 of Statusword is set to 1 and a Following error may occur.

Index	Sub	Name	Data Type	Access	PDO Mapping	Value	EEPROM
6066h	0	Following Error Time Out	UINT	RW	No	0 to 65535 (Default: 0) [ms]	Yes

(7) Following Error Actual Value (60F4h)

This object provides the actual value of the following error.

Index	Sub	Name	Data Type	Access	PDO Mapping	Value	EEPROM
60F4h	0	Following Error Actual Value	DINT	RO	Yes	- [Pos. unit]	No

(8) Position Window (6067h)

This object specifies the positioning completed width for the target position. When the drive completes outputting of the reference to the target position, and the time specified by object 6068h has passed after the distance between the Target Position and the Position Actual Value falls within the value of this object, bit 10 (Target reached) of Statusword is set to 1.

Index	Sub	Name	Data Type	Access	PDO Mapping	Value	EEPROM
6067h	0	Position Window	UDINT	RW	No	0 to 1073741823 (Default: 30) [Pos. unit]	Yes

(9) Position Window Time (6068h)

When the drive completed outputting the reference to the target position, and the time specified by this object has passed after the distance between the Target Position and the Position Actual Value became within the value of object 6067h, the bit 10 (Target reached) of Statusword is set to 1.

Index	Sub	Name	Data Type	Access	PDO Mapping	Value	EEPROM
6068h	0	Position Window Time	UINT	RW	No	0 to 65535 (Default: 0) [ms]	Yes

4.11 Interpolated Position Mode

(1) Interpolation Data Record (60C1h)

This object represents the interpolation position reference in Interpolated Position mode.

Index	Sub	Name	Data Type	Access	PDO Mapping	Value	EEPROM
60C1h	0	Number of entries	USINT	RO	No	1	No
	1	Interpolation data record	DINT	RW	Yes	-2147483648 to +2147483647 (Default: 0) [Pos. unit]	No

(2) Interpolation Time Period (60C2h)

This object defines the update cycle of the interpolated position reference.

If DC Sync0 mode is selected, the interpolation time period value is automatically stored as the Sync0 cycle time.

If DC Free-run mode is selected, the interpolation time period has to be set by the master as the master application cycle time.

This object can be changed only in Switch on Disabled state.

Index	Sub	Name	Data Type	Access	PDO Mapping	Value	EEPROM
60C2h	0	Highest subindex supported	USINT	RO	No	2	No
	1	Interpolation time period	USINT	RW	No	1 to 250 (Default: 125)	No
	2	Interpolation time index	SINT	RW	No	-6 to -3 (Default: -6)	No

$$\text{Interpolation time} = (\text{Object } 60C2h:01h) \times 10^{(\text{Object } 60C2h:02h)} [\text{sec}]$$

4.12 Cyclic Synchronous Position Mode

(1) Velocity Offset (60B1h)

In Cyclic Synchronous Position mode, this object sets the velocity feed forward value.

In Cyclic Synchronous Velocity mode, this object sets the offset value to be added to the velocity reference.

Index	Sub	Name	Data Type	Access	PDO Mapping	Value	EEPROM
60B1h	0	Velocity Offset	DINT	RW	Yes	-2147483648 to +2147483647 (Default: 0) [Vel. unit]	No

(2) Torque Offset (60B2h)

In Cyclic Synchronous Position mode and Cyclic Synchronous Velocity mode, this object sets the torque feed forward value. In Cyclic Synchronous Torque mode, this object sets the offset value to be added to the torque reference.

Index	Sub	Name	Data Type	Access	PDO Mapping	Value	EEPROM
60B2h	0	Torque Offset	INT	RW	Yes	-32768 to +32767 (Default: 0) [0.1%]	No

4.13 Profile Velocity/Cyclic Synchronous Velocity Mode

(1) Velocity Demand Value (606Bh)

This object provides the output value of the velocity trajectory generator or the output value of the position control function.

Index	Sub	Name	Data Type	Access	PDO Mapping	Value	EEPROM
606Bh	0	Velocity Demand Value	DINT	RO	Yes	- [Vel. unit]	No

(2) Velocity Actual Value (606Ch)

This object provides the actual velocity value derived from the position encoder.

Index	Sub	Name	Data Type	Access	PDO Mapping	Value	EEPROM
606Ch	0	Velocity Actual Value	DINT	RO	Yes	- [Vel. unit]	No

(3) Velocity Window (606Dh)

This object indicates the configured velocity window.

When the time specified by the Velocity Window Time (Object 606Eh) has passed after the difference between the target velocity and the velocity actual value falls within the value of this object, bit 10 (Target reached) of Statusword is set to 1.

Index	Sub	Name	Data Type	Access	PDO Mapping	Value	EEPROM
606Dh	0	Velocity Window	UINT	RW	No	0 to 65535 (Default: 20000) [Vel. unit]	Yes

(4) Velocity Window Time (606Eh)

When the time specified by the Velocity Window Time (Object 606Eh) has passed after the difference between the target velocity and the velocity actual value falls within the value of this object, bit 10 (Target reached) of Statusword is set to 1.

Index	Sub	Name	Data Type	Access	PDO Mapping	Value	EEPROM
606Eh	0	Velocity Window Time	UINT	RW	No	0 to 65535 (Default: 0) [ms]	Yes

(5) Target Velocity (60FFh)

This object specifies the target velocity for Profile Velocity mode and Cyclic Synchronous Velocity mode in user defined velocity reference units.

Index	Sub	Name	Data Type	Access	PDO Mapping	Value	EEPROM
60FFh	0	Target Velocity	DINT	RW	Yes	-2147483648 to +2147483647 (Default: 0) [Vel. unit]	No

4.14 Profile Torque/Cyclic Synchronous Torque Mode

(1) Target Torque (6071h)

This object specifies the input value of torque reference value for Torque Control mode. Set the value in units of 0.1% of the motor rated torque.

Index	Sub	Name	Data Type	Access	PDO Mapping	Value	EEPROM
6071h	0	Target Torque	INT	RW	Yes	-32768 to +32767 (Default: 0) [0.1%]	No

(2) Torque Demand Value (6074h)

This object indicates the currently output torque reference value. The value is indicated in units of 0.1% of the motor rated torque.

Index	Sub	Name	Data Type	Access	PDO Mapping	Value	EEPROM
6074h	0	Torque Demand Value	INT	RO	Yes	- [0.1%]	No

(3) Torque Slope (6087h)

This object sets the torque output slope to be used in Profile Torque mode. Set the amount of change per second in units of 0.1% of the motor rated torque.

Index	Sub	Name	Data Type	Access	PDO Mapping	Value	EEPROM
6087h	0	Torque Slope	UDINT	RW	Yes	0 to 4294967295 (Default: 1000) [0.1%/s]	Yes

(4) Motor Rated Torque (6076h)

This object indicates the motor rated torque. The value is indicated in units of mN·m.

Index	Sub	Name	Data Type	Access	PDO Mapping	Value	EEPROM
6076h	0	Motor Rated Torque	UDINT	RO	No	- [mN·m]	No

(5) Torque Actual Value (6077h)

This object specifies the same setting as the torque reference output value.

Index	Sub	Name	Data Type	Access	PDO Mapping	Value	EEPROM
6077h	0	Torque Actual Value	INT	RO	Yes	- [0.1%]	No

4.15 Torque Limit Function

(1) Max. Torque (6072h)

This object sets the maximum output torque to the motor. Set the value in units of 0.1% of the motor rated torque.

The maximum motor torque is automatically set in this object when the power is turned ON.

Index	Sub	Name	Data Type	Access	PDO Mapping	Value	EEPROM
6072h	0	Max. Torque	UINT	RW	Yes	0 to 65535 (Default: max. motor torque) [0.1%]	No

(2) Positive Torque Limit Value (60E0h)

This object sets the positive torque limit value. Set the value in units of 0.1% of the motor rated torque.

Index	Sub	Name	Data Type	Access	PDO Mapping	Value	EEPROM
60E0h	0	Positive Torque Limit Value	UINT	RW	Yes	0 to 65535 (Default: 8000) [0.1%]	Yes

(3) Negative Torque Limit Value (60E1h)

This object sets the negative torque limit value. Set the value in units of 0.1% of the motor rated torque.

Index	Sub	Name	Data Type	Access	PDO Mapping	Value	EEPROM
60E1h	0	Negative Torque Limit Value	UINT	RW	Yes	0 to 65535 (Default: 8000) [0.1%]	Yes

4.16 Touch Probe Function

(1) Touch Probe Function (60B8h)

This object indicates the configured function of the touch probe.

Index	Sub	Name	Data Type	Access	PDO Mapping	Value	EEPROM
60B8h	0	Touch Probe Function	UINT	RW	Yes	0 to 0xFFFF (Default: 0)	No

■ Data Description

Bit	Value	Definition
0	0	Switch off touch probe 1
	1	Enable touch probe 1
1	0	Single trigger mode (Latches the position at the first trigger event.)
	1	Continuous trigger mode (Latches the position every trigger event.)
2	0	Triggers with the probe 1 input.
	1	Triggers with the encoder zero signal (phase-C).
3	–	Reserved
4	0	Switch off sampling at touch probe 1
	1	Enable sampling at touch probe 1
5 to 7	–	Reserved
8	0	Switch off touch probe 2
	1	Enable touch probe 2
9	0	Single trigger mode (Latches the position at the first trigger event.)
	1	Continuous trigger mode (Latches the position every trigger event.)
10	0	Triggers with the probe 2 input.
	1	Reserved
11	–	Reserved
12	0	Switch off sampling at touch probe 2
	1	Enable sampling at touch probe 2
13 to 15	–	Reserved

Note 1. Bit 0 to 7: For touch probe 1

Bit 8 to 15: For touch probe 2

- When the homing function is executing, touch probe 1 function cannot be used. If touch probe 1 function was already enabled, touch probe 1 will be disabled.
- If 1 is specified for bit 1 (i.e., if continuous trigger mode is selected), the setting of bit 2 (trigger selection signal) will be read each time the latch is started. To continuously latch with the same trigger signal, do not change the status of bit 2.

(2) Touch Probe Status (60B9h)

This object provides the status of the touch probe.

Index	Sub	Name	Data Type	Access	PDO Mapping	Value	EEPROM
60B8h	0	Touch Probe Status	UINT	RO	Yes	–	No

■ Data Description

Bit	Value	Definition
0	0	Touch probe 1 is switched off
	1	Touch probe 1 is enabled
1	0	Touch probe 1 no value stored
	1	Touch probe 1 value stored
2 to 6	–	Reserved
7	0, 1	toggle with every update of Touch probe 1 value stored*
8	0	Touch probe 2 is switched off
	1	Touch probe 2 is enabled
9	0	Touch probe 2 no value stored
	1	Touch probe 2 value stored
10 to 14	–	Reserved
15	1	toggle with every update of Touch probe 2 value stored*

* If the continuous latch is enabled (Object 60B8 bit1 = 1, or bit9 = 1), bit7 or bit15 of Object 60B9h is toggled with every update of touch probe value stored.

(3) Touch Probe 1 Position Value (60BAh)

This object provides the position value of the touch probe 1. The value is given in user position units.

Index	Sub	Name	Data Type	Access	PDO Mapping	Value	EEPROM
60BAh	0	Touch Probe 1 Position Value	DINT	RO	Yes	– [Pos. unit]	No

(4) Touch Probe 2 Position Value (60BCh)

This object provides the position value of the touch probe 2. The value is given in user position units.

Index	Sub	Name	Data Type	Access	PDO Mapping	Value	EEPROM
60BCh	0	Touch Probe 2 Position Value	DINT	RO	Yes	– [Pos. unit]	No

4.17 Digital Inputs (60FDh)

This object indicates the digital inputs state of CN1 of the SERVOPACK.

Index	Sub	Name	Data Type	Access	PDO Mapping	Value	EEPROM
60FDh	0	Digital Inputs	UDINT	RO	Yes	–	No

■ Data Description

Bit	Signal	Description
0	N-OT: Negative limit switch	0: Switched off, 1: Switched on
1	P-OT: Positive limit switch	0: Switched off, 1: Switched on
2	Home switch	0: Switched off, 1: Switched on
3 to 19	–	Reserved
20	Probe1 signal	0: Switched off (Open), 1: Switched on (Close)
21	Probe2 signal	0: Switched off (Open), 1: Switched on (Close)
22 to 23	–	Reserved
24	HWBB1	Hardwired base block signal input 1 (0: Open, 1: Close)
25	HWBB2	Hardwired base block signal input 2 (0: Open, 1: Close)
26 to 31	–	Reserved

5

Appendix

5.1 Object List	5-2
5.2 SERVOPACK Parameters	5-8
5.3 SDO Abort Code List	5-8
5.4 Index Numbers and Corresponding Parameter Numbers	5-9

5.1 Object List

Index	Sub Index	Name	Data Type	Access	PDO Mapping	EEPROM *1	Default Value	Lower Limit	Upper Limit	Unit	Pn No. *2
1000h	0	Device Type	UDINT	RO	No	No	0x00020192	–	–	–	–
1001h	0	Error Register	USINT	RO	No	No	–	–	–	–	–
1008h	0	Manufacturer Device Name	STRING	RO	No	No	–	–	–	–	–
100Ah	0	Manufacturer Software Version	STRING	RO	No	No	–	–	–	–	–
1010h	Store Parameters										
	0	Largest subindex supported	USINT	RO	No	No	4	–	–	–	–
	1	Save all parameters	UDINT	RW	No	No	0x00000001	0x00000000	0xFFFFFFFF	–	PnC00
	2	Save communication parameters	UDINT	RW	No	No	0x00000001	0x00000000	0xFFFFFFFF	–	PnC02
	3	Save application parameters	UDINT	RW	No	No	0x00000001	0x00000000	0xFFFFFFFF	–	PnC04
	4	Save manufacturer defined parameters	UDINT	RW	No	No	0x00000001	0x00000000	0xFFFFFFFF	–	PnC06
1011h	Restore Default Parameters										
	0	Largest subindex supported	USINT	RO	No	No	4	–	–	–	–
	1	Restore all default parameters	UDINT	RW	No	No	0x00000001	0x00000000	0xFFFFFFFF	–	PnC08
	2	Restore communication default parameters	UDINT	RW	No	No	0x00000001	0x00000000	0xFFFFFFFF	–	PnC0A
	3	Restore application default parameters	UDINT	RW	No	No	0x00000001	0x00000000	0xFFFFFFFF	–	PnC0C
	4	Restore manufacturer defined default parameters	UDINT	RW	No	No	0x00000001	0x00000000	0xFFFFFFFF	–	PnC0E
1018h	Identity Object										
	0	Number of entries	USINT	RO	No	No	4	–	–	–	–
	1	Vendor ID	UDINT	RO	No	No	0x539	–	–	–	–
	2	Product code	UDINT	RO	No	No	0x02200201 0x02200202 *3	–	–	–	–
	3	Revision number	UDINT	RO	No	No	–	–	–	–	–
	4	Serial number	UDINT	RO	No	No	0	–	–	–	–
10F1h	Sync Error Settings										
	0	Number of entries	USINT	RO	No	No	2	–	–	–	–
	1	Reserved	UDINT	RO	No	No	0	–	–	–	–
	2	Sync error count limit	UDINT	RW	No	No	9	0	15	–	PnCCC

- *1. Write “Save” into the object 1010h. The current parameter data will be saved as a batch in the EEPROM.
If the objects are modified by SigmaWin for Σ-V-SD (MT), the data will be directly stored in the EEPROM.
- *2. Pn No. is the number of the parameter used for SigmaWin for Σ-V-SD (MT).
- *3. SERVOPACK for one axis (CACR-JU□□□□CA): 0x02200201
SERVOPACK for two axes (CACR-JUM□□□□CA): 0x02200202

(cont'd)

Index	Sub Index	Name	Data Type	Access	PDO Mapping	EEPROM *1	Default Value	Lower Limit	Upper Limit	Unit	Pn No.*2
1600h	1st Receive PDO Mapping										
	0	Number of objects in this PDO	USINT	RW	No	Yes	6	0	16	–	PnCA0
	1	Mapping entry 1	UDINT	RW	No	Yes	0x60400010	0	0xFFFFFFFF	–	Pn800
	2	Mapping entry 2	UDINT	RW	No	Yes	0x607A0020	0	0xFFFFFFFF	–	Pn802
	3	Mapping entry 3	UDINT	RW	No	Yes	0x60B10020	0	0xFFFFFFFF	–	Pn804
	4	Mapping entry 4	UDINT	RW	No	Yes	0x60B20010	0	0xFFFFFFFF	–	Pn806
	5	Mapping entry 5	UDINT	RW	No	Yes	0x60B80010	0	0xFFFFFFFF	–	Pn808
	6	Mapping entry 6	UDINT	RW	No	Yes	0x23C80110	0	0xFFFFFFFF	–	Pn80A
	7	Mapping entry 7	UDINT	RW	No	Yes	0	0	0xFFFFFFFF	–	Pn80C
	8	Mapping entry 8	UDINT	RW	No	Yes	0	0	0xFFFFFFFF	–	Pn80E
	9	Mapping entry 9	UDINT	RW	No	Yes	0	0	0xFFFFFFFF	–	Pn810
	10	Mapping entry 10	UDINT	RW	No	Yes	0	0	0xFFFFFFFF	–	Pn812
	11	Mapping entry 11	UDINT	RW	No	Yes	0	0	0xFFFFFFFF	–	Pn814
	12	Mapping entry 12	UDINT	RW	No	Yes	0	0	0xFFFFFFFF	–	Pn816
	13	Mapping entry 13	UDINT	RW	No	Yes	0	0	0xFFFFFFFF	–	Pn818
	14	Mapping entry 14	UDINT	RW	No	Yes	0	0	0xFFFFFFFF	–	Pn81A
	15	Mapping entry 15	UDINT	RW	No	Yes	0	0	0xFFFFFFFF	–	Pn81C
16	Mapping entry 16	UDINT	RW	No	Yes	0	0	0xFFFFFFFF	–	Pn81E	
1A00h	1st Transmit PDO Mapping										
	0	Number of objects in this PDO	USINT	RW	No	Yes	7	0	16	–	PnCA4
	1	Mapping entry 1	UDINT	RW	No	Yes	0x60410010	0	0xFFFFFFFF	–	Pn880
	2	Mapping entry 2	UDINT	RW	No	Yes	0x60640020	0	0xFFFFFFFF	–	Pn882
	3	Mapping entry 3	UDINT	RW	No	Yes	0x606C0020	0	0xFFFFFFFF	–	Pn884
	4	Mapping entry 4	UDINT	RW	No	Yes	0x60770010	0	0xFFFFFFFF	–	Pn886
	5	Mapping entry 5	UDINT	RW	No	Yes	0x60B90010	0	0xFFFFFFFF	–	Pn888
	6	Mapping entry 6	UDINT	RW	No	Yes	0x60BA0020	0	0xFFFFFFFF	–	Pn88A
	7	Mapping entry 7	UDINT	RW	No	Yes	0x23C80210	0	0xFFFFFFFF	–	Pn88C
	8	Mapping entry 8	UDINT	RW	No	Yes	0	0	0xFFFFFFFF	–	Pn88E
	9	Mapping entry 9	UDINT	RW	No	Yes	0	0	0xFFFFFFFF	–	Pn890
	10	Mapping entry 10	UDINT	RW	No	Yes	0	0	0xFFFFFFFF	–	Pn892
	11	Mapping entry 11	UDINT	RW	No	Yes	0	0	0xFFFFFFFF	–	Pn894
	12	Mapping entry 12	UDINT	RW	No	Yes	0	0	0xFFFFFFFF	–	Pn896
	13	Mapping entry 13	UDINT	RW	No	Yes	0	0	0xFFFFFFFF	–	Pn898
	14	Mapping entry 14	UDINT	RW	No	Yes	0	0	0xFFFFFFFF	–	Pn89A
	15	Mapping entry 15	UDINT	RW	No	Yes	0	0	0xFFFFFFFF	–	Pn89C
16	Mapping entry 16	UDINT	RW	No	Yes	0	0	0xFFFFFFFF	–	Pn89E	
1C00h	Sync Manager Communication Type										
	0	Number of used Sync Manager channels	USINT	RO	No	No	4	–	–	–	–
	1	Communication type sync manager 0	USINT	RO	No	No	1	–	–	–	PnCB0
	2	Communication type sync manager 1	USINT	RO	No	No	2	–	–	–	PnCB1
	3	Communication type sync manager 2	USINT	RO	No	No	3	–	–	–	PnCB2
	4	Communication type sync manager 3	USINT	RO	No	No	4	–	–	–	PnCB3

- *1. Write "Save" into the object 1010h. The current parameter data will be saved as a batch in the EEPROM.
If the objects are modified by SigmaWin for Σ -V-SD (MT), the data will be directly stored in the EEPROM.
- *2. Pn No. is the number of the parameter used for SigmaWin for Σ -V-SD (MT).

(cont'd)

Index	Sub Index	Name	Data Type	Access	PDO Mapping	EEPROM*1	Default Value	Lower Limit	Upper Limit	Unit	Pn No.*2
1C10h	0	Sync Manager PDO assignment 0	USINT	RO	No	No	0	–	–	–	–
1C11h	0	Sync Manager PDO assignment 1	USINT	RO	No	No	0	–	–	–	–
1C12h	Sync Manager PDO Assignment2										
	0	Number of assigned PDOs	USINT	RW	No	Yes	1 or 2*3	0	2	–	PnC30
	1	Index of assigned RxPDO 1	UINT	RW	No	Yes	0x1600	0x1600	0x1610	–	PnC31
	2	Index of assigned RxPDO 2	UINT	RW	No	Yes	0x1610	0x1600	0x1610	–	PnC32
1C13h	Sync Manager PDO Assignment3										
	0	Number of assigned PDOs	USINT	RW	No	Yes	1 or 2*3	0	2	–	PnC40
	1	Index of assigned TxPDO 1	UINT	RW	No	Yes	0x1A00	0x1A00	0x1A10	–	PnC41
	2	Index of assigned TxPDO 2	UINT	RW	No	Yes	0x1A10	0x1A00	0x1A10	–	PnC42
1C32h	Sync Manager 2 (process data output) Synchronization										
	0	Number of synchronization parameters	USINT	RO	No	No	12	–	–	–	–
	1	Synchronization type	UINT	RO	No	No	–	–	–	–	PnCC0
	2	Cycle time	UDINT	RO	No	No	–	–	–	–	PnCC2
	3	Shift time	UDINT	RO	No	No	125000	–	–	–	PnCC4
	4	Synchronization types supported	UINT	RO	No	No	0x0005	–	–	–	–
	5	Minimum cycle time	UDINT	RO	No	No	250000	–	–	–	–
	6	Calc and copy time	UDINT	RO	No	No	62500	–	–	–	–
	7	Reserved	UDINT	RO	No	No	0	–	–	–	–
	8	Reserved	UINT	RO	No	No	0	–	–	–	–
	9	Delay time	UDINT	RO	No	No	125000	–	–	–	–
	10	Sync0 cycle time	UDINT	RO	No	No	–	–	–	–	PnCC6
	11	Reserved	UDINT	RO	No	No	0	–	–	–	–
	12	SM2 event miss count	UDINT	RO	No	No	–	–	–	–	PnCC8
1C33h	Sync Manager 3 (process data input) Synchronization										
	0	Number of synchronization parameters	USINT	RO	No	No	10	–	–	–	–
	1	Synchronization type	UINT	RO	No	No	–	–	–	–	–
	2	Cycle time	UDINT	RO	No	No	–	–	–	–	–
	3	Shift time	UDINT	RW	No	Yes	0	0	0xFFFFFFFF	–	PnCCA
	4	Synchronization types supported	UINT	RO	No	No	0x0025	–	–	–	–
	5	Minimum cycle time	UDINT	RO	No	No	250000	–	–	–	–
	6	Calc and copy time	UDINT	RO	No	No	62500	–	–	–	–
	7	Reserved	UDINT	RO	No	No	0	–	–	–	–
	8	Reserved	UINT	RO	No	No	0	–	–	–	–
	9	Delay time	UDINT	RO	No	No	125000	–	–	–	–
	10	Sync0 cycle time	UDINT	RO	No	No	–	–	–	–	–
F000h	Modular Device Profile										
	0	Number of entries	USINT	RO	No	No	2	–	–	–	–
	1	Index distance	UINT	RO	No	No	0x0010	–	–	–	–
	2	Maximum number of modules	UINT	RO	No	No	1/2	–	–	–	–

*1. Write "Save" into the object 1010h. The current parameter data will be saved as a batch in the EEPROM.
If the objects are modified by SigmaWin for Σ-V-SD (MT), the data will be directly stored in the EEPROM.

*2. Pn No. is the number of the parameter used for SigmaWin for Σ-V-SD (MT).

*3. SERVOPACK for one axis: 1
SERVOPACK for two axes: 2

(cont'd)

Index	Sub Index	Name	Data Type	Access	PDO Mapping	EEPROM *1	Default Value	Lower Limit	Upper Limit	Unit	Pn No.*2
2000h to 22FFh	0	SERVOPACK Parameter (Pn000 - Pn6FF)	-	-	-	-	-	-	-	-	Pn000 - Pn6FF
2300h	0	User Parameter Configuration	UDINT	RW	No	No	0	0	0xFFFFFFFF	-	PnB00
2301h	Position User Unit										
	0	Number of entries	USINT	RO	No	No	2	-	-	-	-
	1	Numerator	UDINT	RW	No	Yes	1	1	1073741823	-	PnB02
	2	Denominator	UDINT	RW	No	Yes	1	1	1073741823	-	PnB04
2302h	Velocity User Unit										
	0	Number of entries	USINT	RO	No	No	2	-	-	-	-
	1	Numerator	UDINT	RW	No	Yes	1	1	1073741823	-	PnB06
	2	Denominator	UDINT	RW	No	Yes	1	1	1073741823	-	PnB08
2303h	Acceleration User Unit										
	0	Number of entries	USINT	RO	No	No	2	-	-	-	-
	1	Numerator	UDINT	RW	No	Yes	1	1	1073741823	-	PnB0A
	2	Denominator	UDINT	RW	No	Yes	1	1	1073741823	-	PnB0C
2310h	SERVOPACK Adjusting Command										
	0	Number of entries	USINT	RO	No	No	3	-	-	-	-
	1	Command	STRING	RW	No	No	0	0	0xFF	-	-
	2	Status	USINT	RO	No	No	-	-	-	-	-
	3	Reply	STRING	RO	No	No	-	-	-	-	-
	Machine tools Objects										
23C8h	0	Number of entries	USINT	RO	No	No	3	-	-	-	-
	1	Machine tool function	UINT	RW	Yes	No	0	0	0xFFFF	-	PnBA0
	2	Machine tool Status	UINT	RO	Yes	No	0	0	0xFFFF	-	PnBA1
	3	Load meter	UINT	RO	Yes	No	0	0	65535	0.1%	PnBA2
23E0h	-	Diag.Mode	UINT	RW	No	No	0	0	0xFFFF	-	PnCFE
603Fh	0	Error Code	UINT	RO	Yes	No	-	-	-	-	PnB10
6040h	0	Controlword	UINT	RW	Yes	No	0	0	0xFFFF	-	PnB11
6041h	0	Statusword	UINT	RO	Yes	No	-	-	-	-	PnB12
605Ah	0	Quick Stop Option Code	INT	RW	No	Yes	2	0	4	-	PnB13
605Bh	0	Shutdown Option Code	INT	RW	No	Yes	0	0	1	-	PnB14
605Ch	0	Disable Operation Option Code	INT	RW	No	Yes	1	0	1	-	PnB15
605Dh	0	Halt Option Code	INT	RW	No	Yes	1	0	4	-	PnB16
605Eh	0	Fault Reaction Option Code	INT	RW	No	Yes	0	0	0	-	PnB17
6060h	0	Modes of Operation	SINT	RW	Yes	Yes	0	0	10	-	PnB18
6061h	0	Modes of Operation Display	SINT	RO	Yes	No	0	-	-	-	PnB19
6062h	0	Position Demand Value	DINT	RO	Yes	No	-	-	-	Pos. unit	PnB20
6063h	0	Position Actual Internal Value	DINT	RO	Yes	No	-	-	-	Inc	PnB22
6064h	0	Position Actual Value	DINT	RO	Yes	No	-	-	-	Pos. unit	PnB24
6065h	0	Following Error Window	UDINT	RW	No	Yes	5242880	0	1073741823	Pos. unit	PnB26
6066h	0	Following Error Time Out	UINT	RW	No	Yes	0	0	65535	ms	PnB28
6067h	0	Position Window	UDINT	RW	No	Yes	30	0	1073741823	Pos. unit	PnB2A

- *1. Write "Save" into the object 1010h. The current parameter data will be saved as a batch in the EEPROM.
If the objects are modified by SigmaWin for Σ -V-SD (MT), the data will be directly stored in the EEPROM.
- *2. Pn No. is the number of the parameter used for SigmaWin for Σ -V-SD (MT).

(cont'd)

Index	Sub Index	Name	Data Type	Access	PDO Mapping	EEPROM *1	Default Value	Lower Limit	Upper Limit	Unit	Pn No. *2
6068h	0	Position Window Time	UINT	RW	No	Yes	0	0	65535	ms	PnB2C
606Bh	0	Velocity Demand Value	DINT	RO	Yes	No	–	–	–	Vel. Unit	PnB2E
606Ch	0	Velocity Actual Value	DINT	RO	Yes	No	–	–	–	Vel. Unit	PnB30
606Dh	0	Velocity Window	UINT	RW	No	Yes	20000	0	65535	Vel. Unit	PnB32
606Eh	0	Velocity Window Time	UINT	RW	No	Yes	0	0	65535	ms	PnB34
6071h	0	Target Torque	INT	RW	Yes	No	0	-32768	32767	0.1%	PnB36
6072h	0	Max. Torque	UINT	RW	Yes	No	Motor max. torque	0	65535	0.1%	PnB38
6074h	0	Torque Demand Value	INT	RO	Yes	No	–	–	–	0.1%	PnB3A
6076h	0	Motor Rated Torque	UDINT	RO	No	No	–	–	–	mN·m	PnB3C
6077h	0	Torque Actual Value	INT	RO	Yes	No	–	–	–	0.1%	PnB3E
607Ah	0	Target Position	DINT	RW	Yes	No	0	-2147483648	2147483647	Pos. unit	PnB40
607Ch	–	Home Offset	DINT	RW	No	Yes	0	-536870912	536870911	Pos. unit	PnB46
607Dh	Software Position Limit										
	0	Number of entries	USINT	RO	No	No	2	–	–	–	–
	1	Min. position limit	DINT	RW	No	Yes	0	-536870912	536870911	Pos. unit	PnB48
	2	Max. position limit	DINT	RW	No	Yes	0	-536870912	536870911	Pos. unit	PnB4A
607Fh	0	Max. Profile Velocity	UDINT	RW	Yes	Yes	2147483647	0	4294967295	Vel. Unit	PnB4C
6081h	0	Profile Velocity	UDINT	RW	Yes	Yes	0	0	4294967295	Vel. Unit	PnB4E
6083h	0	Profile Acceleration	UDINT	RW	Yes	Yes	1000	0	4294967295	Acc. Unit	PnB50
6084h	0	Profile Deceleration	UDINT	RW	Yes	Yes	1000	0	4294967295	Acc. Unit	PnB52
6085h	0	Quick Stop Deceleration	UDINT	RW	Yes	Yes	1000	0	4294967295	Acc. Unit	PnB54
6087h	0	Torque Slope	UDINT	RW	Yes	Yes	1000	0	4294967295	0.1 %/s	PnB56
6098h	0	Homing Method	SINT	RW	Yes	No	35	0	35	–	PnB58
6099h	Homing Speeds										
	0	Number of entries	USINT	RO	No	No	2	–	–	–	–
	1	Speed during search for switch	UDINT	RW	Yes	Yes	500000	0	4294967295	Vel. Unit	PnB5A
	2	Speed during search for zero	UDINT	RW	Yes	Yes	100000	0	4294967295	Vel. Unit	PnB5C
609Ah	0	Homing Acceleration	UDINT	RW	Yes	Yes	1000	0	4294967295	Acc. Unit	PnB5E
60B1h	0	Velocity Offset	DINT	RW	Yes	No	0	-2147483648	2147483647	Vel. Unit	PnB60
60B2h	0	Torque Offset	INT	RW	Yes	No	0	-32768	32767	0.1%	PnB62
60B8h	0	Touch Probe Function	UINT	RW	Yes	No	0	0	0xFFFF	–	PnB64
60B9h	0	Touch Probe Status	UINT	RO	Yes	No	–	–	–	–	PnB66
60BAh	0	Touch Probe 1 position Value	DINT	RO	Yes	No	–	–	–	Pos. unit	PnB68
60BCh	0	Touch Probe 2 position Value	DINT	RO	Yes	No	–	–	–	Pos. unit	PnB6A

*1. Write "Save" into the object 1010h. The current parameter data will be saved as a batch in the EEPROM.
If the objects are modified by SigmaWin for Σ-V-SD (MT), the data will be directly stored in the EEPROM.

*2. Pn No. is the number of the parameter used for SigmaWin for Σ-V-SD (MT).

(cont'd)

Index	Sub Index	Name	Data Type	Access	PDO Mapping	EEPROM *1	Default Value	Lower Limit	Upper Limit	Unit	Pn No.*2
60C1h	Interpolation Data Record										
	0	Number of entries	USINT	RO	No	No	1	–	–	–	–
	1	Interpolation data record	DINT	RW	Yes	No	0	-2147483648	2147483647	Pos. unit	PnB70
60C2h	Interpolation Time Period										
	0	Highest subindex supported	USINT	RO	No	No	2	–	–	–	–
	1	Interpolation time period	USINT	RW	No	No	125	1	250	–	PnB6E
	2	Interpolation time index	SINT	RW	No	No	-6	-6	-3	–	PnB6F
60E0h	0	Positive Torque Limit Value	UINT	RW	Yes	Yes	8000	0	65535	0.1%	PnB80
60E1h	0	Negative Torque Limit Value	UINT	RW	Yes	Yes	8000	0	65535	0.1%	PnB82
60F4h	0	Following Error Actual Value	DINT	RO	Yes	No	–	–	–	Pos. unit	PnB84
60FCh	0	Position Demand Internal Value	DINT	RO	Yes	No	–	–	–	Inc	PnB86
60FDh	0	Digital Inputs	UDINT	RO	Yes	No	–	–	–	–	PnB88
60FFh	0	Target Velocity	DINT	RW	Yes	No	0	-2147483648	2147483647	Vel. Unit	PnB8E
6502h	0	Supported Drive Modes	UDINT	RO	No	No	0x03ED	–	–	–	PnB90

- *1. Write “Save” into the object 1010h. The current parameter data will be saved as a batch in the EEPROM.
If the objects are modified by SigmaWin for Σ -V-SD (MT), the data will be directly stored in the EEPROM.
- *2. Pn No. is the number of the parameter used for SigmaWin for Σ -V-SD (MT).

5.2 SERVOPACK Parameters

All SERVOPACK parameters can be accessed by SDO communication.

For details on SERVOPACK parameters, refer to *Σ-V-SD series User's Manual Design and Maintenance Rotational Motor EtherCAT (CoE) Communications Reference (manual no.: SIEP S800000 94)*.

5.3 SDO Abort Code List

The following table shows the SDO abort codes for SDO communication errors.

Value	Meaning
0x05 03 00 00	Toggle bit not changed
0x05 04 00 00	SDO protocol timeout
0x05 04 00 01	Client/Server command specifier not valid or unknown
0x05 04 00 05	Out of memory
0x06 01 00 00	Unsupported access to an object
0x06 01 00 01	Attempt to read to a write only object
0x06 01 00 02	Attempt to write to a read only object
0x06 02 00 00	The object does not exist in the object directory
0x06 04 00 41	The object cannot be mapped into the PDO
0x06 04 00 42	The number and length of the objects to be mapped would exceed the PDO length
0x06 04 00 43	General parameter incompatibility reason
0x06 04 00 47	General internal incompatibility in the device
0x06 06 00 00	Access failed due to a hardware error
0x06 07 00 10	Data type does not match, length of service parameter does not match
0x06 07 00 12	Data type does not match, length of service parameter too high
0x06 07 00 13	Data type does not match, length of service parameter too low
0x06 09 00 11	Subindex does not exist
0x06 09 00 30	Value range of parameter exceeded (only for write access)
0x06 09 00 31	Value of parameter written too high
0x06 09 00 32	Value of parameter written too low
0x06 09 00 36	Maximum value is less than minimum value
0x08 00 00 00	General error
0x08 00 00 20	Data cannot be transferred or stored to the application
0x08 00 00 21	Data cannot be transferred or stored to the application because of local control
0x08 00 00 22	Data cannot be transferred or stored to the application because of the present device

5.4 Index Numbers and Corresponding Parameter Numbers

Use the following table to find the parameter numbers that correspond to the index numbers of the EtherCAT (CoE) commands of the Σ -V-SD Driver.

Supplemental Information

The index numbers for a SERVOPACK for one axis and axis 1 of a SERVOPACK for two axes are given for the index numbers of the servo parameters. The index numbers for axis 2 of a SERVOPACK for two axes can be calculated by adding 400 hex to the index numbers for axis 1.

Example:

Parameter number: Pn100

= Index number for axis 1: 2040h

↓ Add 400 hex to calculate the index number for axis 2.

= Index number for axis 2: 2440h

Index Number	Parameter	Name
2000h	Pn000	Basic Function Select Switch 0
2001h	Pn001	Application Function Select Switch 1
2002h	Pn002	Application Function Select Switch 2
2006h	Pn006	Application Function Select Switch 6
2007h	Pn007	Application Function Select Switch 7
2008h	Pn008	Application Function Select Switch 8
200Bh	Pn00B	Application Function Select Switch B
200Dh	Pn00D	Application Function Select Switch D
2030h:1	Pn01B	Application Function Select Switch 1B
2030h:2	Pn01C	Application Function Select Switch 1C
2030h:3	Pn01E	Application Function Select Switch 1E
2030h:4	Pn01F	Application Function Select Switch 1F
2030h:5	Pn070	Function at Cutting Feed
2030h:6	Pn071	Function at Fast-forward
2030h:7	Pn07F	Application Function Select Switch 7F
2040h:1	Pn100	Speed Loop Gain
2040h:2	Pn101	Speed Loop Integral Time Constant
2040h:3	Pn102	Position Loop Gain
2040h:4	Pn401	1st Step 1st Torque Reference Filter Time Constant
2041h:1	Pn104	2nd Speed Loop Gain
2041h:2	Pn105	2nd Speed Loop Integral Time Constant
2041h:3	Pn106	2nd Position Loop Gain
2041h:4	Pn412	1st Step 2nd Torque Reference Filter Time Constant
2042h:1	Pn12B	3rd Speed Loop Gain
2042h:2	Pn12C	3rd Speed Loop Integral Time Constant
2042h:3	Pn12D	3rd Position Loop Gain
2042h:4	Pn413	1st Step 3rd Torque Reference Filter Time Constant
2043h:1	Pn12E	4rd Speed Loop Gain
2043h:2	Pn12F	4rd Speed Loop Integral Time Constant
2043h:3	Pn130	4rd Position Loop Gain
2043h:4	Pn414	1st Step 4th Torque Reference Filter Time Constant
2060h	Pn103	Moment of Inertia Ratio
2061h	Pn109	Feedforward Gain
2062h	Pn10A	Feedforward Filter Time Constant

(cont'd)

Index Number	Parameter	Name
2065h	Pn10B	Application Function for Gain Select Switch
2067h:1	Pn121	Friction Compensation Gain
2067h:3	Pn123	Friction Compensation Coefficient
2067h:4	Pn124	Friction Compensation Frequency Correction
2067h:5	Pn125	Friction Compensation Gain Correction
206Ah:1	Pn140	Model Following Control Related Switch
206Ah:2	Pn141	Model Following Control Gain
206Ah:3	Pn142	Model Following Control Gain Compensation
206Ah:4	Pn143	Model Following Control Bias (Forward Direction)
206Ah:5	Pn144	Model Following Control Bias (Reverse Direction)
206Ah:8	Pn147	Model Following Control Speed Feedforward Compensation
206Bh:1	Pn160	Anti-Resonance Control Related Switch
206Bh:2	Pn161	Anti-Resonance Frequency
206Bh:3	Pn162	Anti-Resonance Gain Compensation
206Bh:4	Pn163	Anti-Resonance Damping Gain
206Bh:5	Pn164	Anti-Resonance Filter Time Constant 1 Compensation
206Bh:6	Pn165	Anti-Resonance Filter Time Constant 2 Compensation
2083h	Pn22A	Fully-closed Control Selection Switch
208Ah:1	Pn150	Predictive Control Function Select Switch
208Ah:2	Pn151	Predictive Control Acceleration/Deceleration Gain
208Ah:3	Pn152	Predictive Control Ratio of Weight
208Ah:4	Pn153	Predictive Control Equivalent Kp Ratio
208Ah:5	Pn154	Predictive Control Speed FF Gain
208Ah:6	Pn155	Predictive Control Torque FF Gain
208Ah:7	Pn156	Predictive Control Torque FF Filter Time Constant
208Ah:8	Pn157	Predictive Control Parameter Kph(C)
208Ah:9	Pn158	Predictive Control Parameter Cd
208Ah:10	Pn159	Predictive Control Parameter α
208Ah:11	Pn15A	Predictive Control Equivalent Kp Fine Adjustment Amount
2090h	Pn305	Soft Start Acceleration Time
2091h	Pn306	Soft Start Deceleration Time
2094h:2	Pn311	Vibration Detection Sensibility
2098h:1	Pn541	Rated Speed Setting
2098h:2	Pn542	Speed Coincidence Detection Width
2098h:3	Pn543	Speed Detection Level
2098h:4	Pn544	Speed Detection Hysteresis
2098h:5	Pn545	Speed Error Excessive Protection Select Switch
20A0h:1	Pn402	Forward Torque Limit
20A0h:2	Pn403	Reverse Torque Limit
20A2h	Pn406	Emergency Stop Torque
20A3h:1	Pn404	Forward External Torque Limit
20A3h:2	Pn405	Reverse External Torque Limit
20A5h	Pn407	Speed Limit during Torque Control
20A7h	Pn408	Torque Related Function Switch
20A9h:1	Pn409	1st Notch Filter Frequency

(cont'd)

Index Number	Parameter	Name
20A9h:2	Pn40A	1st Notch Filter Q Value
20A9h:3	Pn40B	1st Notch Filter Depth
20A9h:4	Pn40C	2nd Notch Filter Frequency
20A9h:5	Pn40D	2nd Notch Filter Q Value
20A9h:6	Pn40E	2nd Notch Filter Depth
20A9h:7	Pn460	Notch Filter Adjustment Switch
20A9h:8	Pn417	3rd Notch Filter Frequency
20A9h:9	Pn418	3rd Notch Filter Q Value
20A9h:10	Pn419	3rd Notch Filter Depth
20A9h:11	Pn41A	4rd Notch Filter Frequency
20A9h:12	Pn41B	4rd Notch Filter Q Value
20A9h:13	Pn41C	4rd Notch Filter Depth
20A9h:14	Pn416	Torque Related Function Switch 2
20AAh:1	Pn430	Torque Limit (Powering)
20AAh:2	Pn431	Torque Limit (Regeneration)
20ABh:1	Pn432	Motor Flux Lower Level
20ABh:2	Pn433	Servo Mode Flux Level (for High-speed Winding)
20ABh:3	Pn434	Servo Mode Base Speed Ratio (for High-speed Winding)
20ABh:4	Pn435	Servo Mode Flux Level (for Low-speed Winding)
20ABh:5	Pn436	Servo Mode Base Speed Ratio (for Low-speed Winding)
20ACh:1	Pn43F	Load Ratio Meter Filter Time Constant
20ADh:1	Pn4F0	1st Positive Projection Compensation Gain
20ADh:2	Pn4F1	1st Positive Projection Compensation Limit Offset
20ADh:3	Pn4F2	2nd Positive Projection Compensation Gain
20ADh:4	Pn4F3	2nd Positive Projection Compensation Limit Offset
20ADh:5	Pn4F4	Positive Projection Compensation Limit Change Value
20ADh:6	Pn4F5	Positive Projection Compensation Limit Clamp Value
20ADh:7	Pn4F6	1st Negative Projection Compensation Gain
20ADh:8	Pn4F7	1st Negative Projection Compensation Limit Offset
20ADh:9	Pn4F8	2nd Negative Projection Compensation Gain
20ADh:10	Pn4F9	2nd Negative Projection Compensation Limit Offset
20ADh:11	Pn4FA	Negative Projection Compensation Limit Change Value
20ADh:12	Pn4FB	Negative Projection Compensation Limit Clamp Value
20ADh:13	Pn4FC	Projection Compensation Timing Constant
20C0h	Pn205	Multiturn Limit Setting
20C1h	Pn20A	Number of External Scale Pitch
20C8h:1	Pn481	Magnetic Pole Detection Speed Loop Gain
20C8h:2	Pn482	Magnetic Pole Detection Speed Integral Time
20C8h:4	Pn486	Magnetic Pole Detection Command Acceleration/Deceleration Time
20C8h:5	Pn487	Magnetic Pole Detection Command Constant Speed Time
20C8h:6	Pn488	Magnetic Pole Detection Command Waiting Time
20C8h:9	Pn490	Magnetic Pole Detection Load Level
20C8h:12	Pn493	Magnetic Pole Detection Command Speed
20C8h:13	Pn494	Magnetic Pole Detection Variable Range
20C8h:14	Pn495	Magnetic Pole Detection Confirmation Torque Reference

(cont'd)

Index Number	Parameter	Name
20C8h:17	Pn498	Polarity Detection Allowable Error Range
20C8h:18	Pn499	Reserved (Do not change.)
20C8h:19	Pn49A	Reserved (Do not change.)
20D0h:1	Pn230	Number of Encoder Pulse
20D0h:2	Pn232	C-Phase Compensation Width
20D0h:3	Pn233	Magnetic Pole Origin Corrected Value
20D0h:4	Pn234	Resist Vibration for Pulse Encoder
2100h:1	Pn501	Zero Clamp Level
2100h:2	Pn502	Rotation Detection Level
2100h:3	Pn503	Speed Coincidence Signal Output Width
2102h:1	Pn51E	Excessive Position Error Warning Level
2102h:2	Pn520	Excessive Position Error Alarm Level
2102h:3	Pn522	Positioning Completed Width
2102h:4	Pn524	NEAR Signal Width
2102h:5	Pn51B	Excessive Error Level between Servomotor and Load Positions
2102h:6	Pn52A	Multiplier per One Fully-closed Rotation
2103h:1	Pn526	Excessive Position Error Alarm Level at Servo ON
2103h:2	Pn528	Excessive Position Error Warning Level at Servo ON
2103h:3	Pn529	Speed Limit Level at Servo ON
2104h:1	Pn52B	Overload Warning Level
2104h:2	Pn52C	Derating of Base Current at Detecting Overload of Motor
2110h:1	Pn50A	Input Signal Selection 1
2110h:2	Pn50B	Input Signal Selection 2
2110h:3	Pn511	Probe1, Probe2, HOME Input Signal setting
2110h:4	Pn517	OT Function
2112h:1	Pn506	Brake Reference - Servo OFF Delay Time
2112h:2	Pn507	Brake Reference Output Speed Level
2112h:4	Pn508	Waiting Time for Brake Signal When Motor Running
2114h	Pn601	DB Resistor Capacity
2116h:1	Pn550	Analog Monitor 1 Offset Voltage
2116h:2	Pn551	Analog Monitor 2 Offset Voltage
2116h:3	Pn552	Analog Monitor Magnification (×1)
2116h:4	Pn553	Analog Monitor Magnification (×2)
2118h:1	Pn630	Emergency Stop Execution Delay Time
2118h:2	Pn631	External Magnetic Contactor OFF Delay Time
2140h	Pn304	JOG Speed
2142h:1	Pn530	Program JOG Operation Related Switch
2142h:2	Pn531	Program JOG Movement Distance
2142h:3	Pn533	Program JOG Movement Speed
2142h:4	Pn534	Program JOG Acceleration/Deceleration Time
2142h:5	Pn535	Program JOG Waiting Time
2142h:6	Pn536	Number of Times of Program JOG Movement
2143h	Pn324	Moment of Inertia Calculating Start Level
2146h:4	Pn456	Sweep Torque Reference Amplitude
2148h	Pn561	Overshoot Detection Level

(cont'd)

Index Number	Parameter	Name
5C00h	Pn010	SERVOPACK Address (for USB/Local bus communication)

Index

A

Acceleration User Unit (2703h) ----- 4-14
 applicable communication standards ----- 1-5

B

base block (BB) ----- iii

C

CANopen ----- 1-2
 CiA402 drive profile ----- 1-5, 3-2
 CoE technical terms ----- 1-3
 data type ----- 1-4
 data units ----- 1-4
 Controlword (6040h) ----- 4-20
 cycle time ----- 4-11
 cyclic sync torque mode ----- 3-15
 cyclic synchronous position mode ----- 3-8, 4-34
 cyclic synchronous velocity mode ----- 3-13

D

data type ----- 1-4
 data units ----- 1-4
 DC mode ----- 2-8, 2-9
 device control ----- 3-2
 Device Control ----- 4-20
 Device Type (1000h) ----- 4-4
 digital inputs ----- 3-16, 4-40
 DINT ----- 1-4
 Disable Operation Option Code (605Ch) ----- 4-25
 distributed clocks ----- 1-5
 drive profile ----- 1-5, 3-2

E

emergency messages ----- 2-10
 Error Code (603Fh) ----- 4-20
 Error Register (1001h) ----- 4-4
 EtherCAT commands ----- 1-5
 EtherCAT communications ----- 1-5
 EtherCAT Slave Information ----- 2-3
 EtherCAT state machine ----- 2-4
 event
 cycle time ----- 4-11
 receive (SM2) event ----- 4-12
 Sync0 event ----- 2-8
 trigger events ----- 3-17

F

Fault Reaction Option Code (605Eh) ----- 4-26
 Fieldbus connection ----- 1-5
 FMMU ----- 1-5
 FMMU settings ----- 2-2
 Following Error Actual Value (60F4h) ----- 4-33
 Following Error Time Out (6066h) ----- 4-32
 Following Error Window (6065h) ----- 4-32
 free run mode ----- 2-8
 Fully-closed Control ----- 3-19

G

General Objects ----- 4-4

H

Halt Option Code (605Dh) ----- 4-26
 Hard Wire Base Block (HWBB) Function ----- 3-19
 Home Offset (607Ch) ----- 4-30
 homing ----- 3-9
 Homing Acceleration (609Ah) ----- 4-31
 Homing Method (6098h) ----- 3-9, 4-30
 homing mode ----- 4-30
 Homing Speeds (6099h) ----- 4-31

I

Identity Object (1018h) ----- 4-7
 index number ----- iv
 Index Numbers and Corresponding Parameter Numbers ----- 5-9
 INT ----- 1-4
 interpolated position mode ----- 3-7, 4-34
 interpolated positioning ----- 3-8
 interpolation ----- 3-7
 Interpolation Data Record (60C1h) ----- 4-34
 Interpolation Time Period (60C2h) ----- 4-34

L

LED indicators ----- 1-5, 1-6

M

Machine Tools Object (23C8h) ----- 4-19
 mailbox ----- 1-5
 Manufacturer Device Name (1008h) ----- 4-4
 Manufacturer Software Version (100Ah) ----- 4-4
 Manufacturer Specific Objects ----- 4-13
 Max. Profile Velocity (607Fh) ----- 4-28
 Max. Torque (6072h) ----- 4-37
 modes of operation ----- 3-4
 Modes of Operation (6060h) ----- 4-26
 Modes of Operation Display (6061h) ----- 4-27
 Motor Rated Torque (6076h) ----- 4-36

N

Negative Torque Limit Value (60E1h) ----- 4-37

O

object dictionary ----- 2-6
 object dictionary list ----- 4-2
 object list ----- 5-2
 over interpolation speed ----- 4-23

P

parameters ----- 5-8
 PDO mapping ----- 2-6, 4-8
 default PDO mappings ----- 2-7
 object dictionary ----- 2-6
 object dictionary list ----- 4-2
 setup procedure ----- 2-7
 PDO mapping objects ----- 4-8
 physical layer ----- 1-5
 Position Actual Internal Value (6063h) ----- 4-32
 Position Actual Value (6064h) ----- 4-32
 Position Control Function ----- 4-32
 Position Control Modes ----- 3-5
 Position Demand Internal Value (60FCh) ----- 4-32
 Position Demand Value (6062h) ----- 4-32
 Position User Unit (2701h) ----- 4-13
 Position Window (6067h) ----- 4-33
 Position Window Time (6068h) ----- 4-33
 Positive Torque Limit Value (60E0h) ----- 4-37
 power regeneration converter ----- iii

process data	1-5
Profile Acceleration (6083h)	4-29
Profile Deceleration (6084h)	4-29
profile position mode	3-5, 4-28
profile torque mode	3-14
Profile Torque/Cyclic Synchronous Torque Mode	4-36
Profile Velocity (6081h)	4-29
profile velocity mode	3-12
Profile Velocity/Cyclic Synchronous Velocity Mode	4-35

Q

quick stop command	4-29
Quick Stop Deceleration (6085h)	4-29
quick stop function	4-24
Quick Stop Option Code (605Ah)	4-24

R

receive (SM2) event	4-12
receive PDO mapping	4-8
Restore Default Parameters (1011h)	4-6

S

SDO abort code list	5-8
servo drive	iii
servo OFF	iii
servo ON	iii
Servomotor	iii
SERVOPACK	iii
parameters	5-8
SERVOPACK Adjusting Command (2310h)	4-17
SERVOPACK for One Axis	iii
SERVOPACK for Two Axes	iii
SERVOPACK Parameters	5-8
SERVOPACK Parameters (2000h-22FFh)	4-13
Shutdown Option Code (605Bh)	4-25
SINT	1-4
slave information IF	1-5
Software Position Limit (607Dh)	4-28
Spindle Motor	iii
state machine controlling command	3-3
Statusword (6041h)	3-3, 4-22
Store Parameters (1010h)	4-5
STRING	1-4
Supported Drive Modes (6502h)	4-27
Σ -V-SD driver	iii
Sync Error Setting (1F01h)	4-12
sync manager communication objects	4-10
Sync Manager Communication Type (1C00h)	4-10
Sync Manager PDO Assignment (1C10h to 1C13h)	4-10
sync manager settings	2-2
Sync Manager Synchronization (1C32h, 1C33h)	4-11
Sync0 event	2-8
synchronization with distributed clocks	2-8
example of PDO data exchange timing with DC mode	2-9
SyncManager	1-5

T

Target Position (607Ah)	4-28
Target Torque (6071h)	4-36
Target Velocity (60FFh)	4-35
Torque Actual Value (6077h)	4-36
Torque Demand Value (6074h)	4-36
torque limit function	3-16, 4-37
Torque Offset (60B2h)	4-34
Torque Slope (6087h)	4-36
Torque Control Modes	3-14

Touch Probe 1 Position Value (60BAh)	4-39
Touch Probe 2 Position Value (60BCh)	4-39
touch probe function	3-17, 3-18
example of handshaking procedure	3-18
Touch Probe Function (60B8h)	4-38
Touch Probe Status (60B9h)	4-39
transmit PDO mapping	4-9
trigger events	3-17

U

UDINT	1-4
UINT	1-4
User Parameter Configuration (2300h)	4-13
USINT	1-4

V

Velocity Actual Value (606Ch)	4-35
Velocity Control Modes	3-12
Velocity Demand Value (606Bh)	4-35
Velocity Offset (60B1h)	4-34
Velocity User Unit (2702h)	4-14
Velocity Window (606Dh)	4-35
Velocity Window Time (606Eh)	4-35

Revision History

The revision dates and numbers of the revised manuals are given on the bottom of the back cover.

MANUAL NO. SIEP S800000 95A

Published in Japan March 2013 13-3
└ Date of publication └ Date of original publication

Date of Publication	Rev. No.	Section	Revised Content
March 2013	—	—	First edition

AC Servo Drives Σ -V-SD Series USER'S MANUAL For Command Profile

Rotational Motor EtherCAT (CoE) Communications Reference

IRUMA BUSINESS CENTER (SOLUTION CENTER)

480, Kamifujisawa, Iruma, Saitama 358-8555, Japan
Phone 81-4-2962-5151 Fax 81-4-2962-6138

YASKAWA AMERICA, INC.

2121 Norman Drive South, Waukegan, IL 60085, U.S.A.
Phone 1-800-YASKAWA (927-5292) or 1-847-887-7000 Fax 1-847-887-7310

YASKAWA ELÉTRICO DO BRASIL LTDA.

Avenida Piraporinha 777, Diadema, São Paulo, 09950-000, Brasil
Phone 55-11-3585-1100 Fax 55-11-3585-1187

YASKAWA EUROPE GmbH

Hauptstraße 185, Eschborn 65760, Germany
Phone 49-6196-569-300 Fax 49-6196-569-398

YASKAWA ELECTRIC UK LTD.

1 Hunt Hill Orchardton Woods Cumbernauld, G68 9LF, United Kingdom
Phone 44-1236-735000 Fax 44-1236-458182

YASKAWA ELECTRIC KOREA CORPORATION

9F, Kyobo Securities Bldg. 26-4, Yeouido-dong, Yeongdeungpo-gu, Seoul, 150-737, Korea
Phone 82-2-784-7844 Fax 82-2-784-8495

YASKAWA ELECTRIC (SINGAPORE) PTE. LTD.

151 Lorong Chuan, #04-02A, New Tech Park 556741, Singapore
Phone 65-6282-3003 Fax 65-6289-3003

YASKAWA ELECTRIC (CHINA) CO., LTD.

12F, Carlton Bld., No.21 HuangHe Road, HuangPu District, Shanghai 200003, China
Phone 86-21-5385-2200 Fax 86-21-5385-3299

YASKAWA ELECTRIC (CHINA) CO., LTD. BEIJING OFFICE

Room 1011, Tower W3 Oriental Plaza, No.1 East Chang An Ave.,
Dong Cheng District, Beijing 100738, China
Phone 86-10-8518-4086 Fax 86-10-8518-4082

YASKAWA ELECTRIC TAIWAN CORPORATION

9F, 16, Nanking E. Rd., Sec. 3, Taipei 104, Taiwan
Phone 886-2-2502-5003 Fax 886-2-2505-1280



YASKAWA ELECTRIC CORPORATION

In the event that the end user of this product is to be the military and said product is to be employed in any weapons systems or the manufacture thereof, the export will fall under the relevant regulations as stipulated in the Foreign Exchange and Foreign Trade Regulations. Therefore, be sure to follow all procedures and submit all relevant documentation according to any and all rules, regulations and laws that may apply.

Specifications are subject to change without notice for ongoing product modifications and improvements.

© 2013 YASKAWA ELECTRIC CORPORATION. All rights reserved.

MANUAL NO. SIEP S800000 95A

Published in Japan March 2013 13-3

12-12-8

Original instructions