

# GPD 503 - SysBus & SysBus/2 Serial Communications

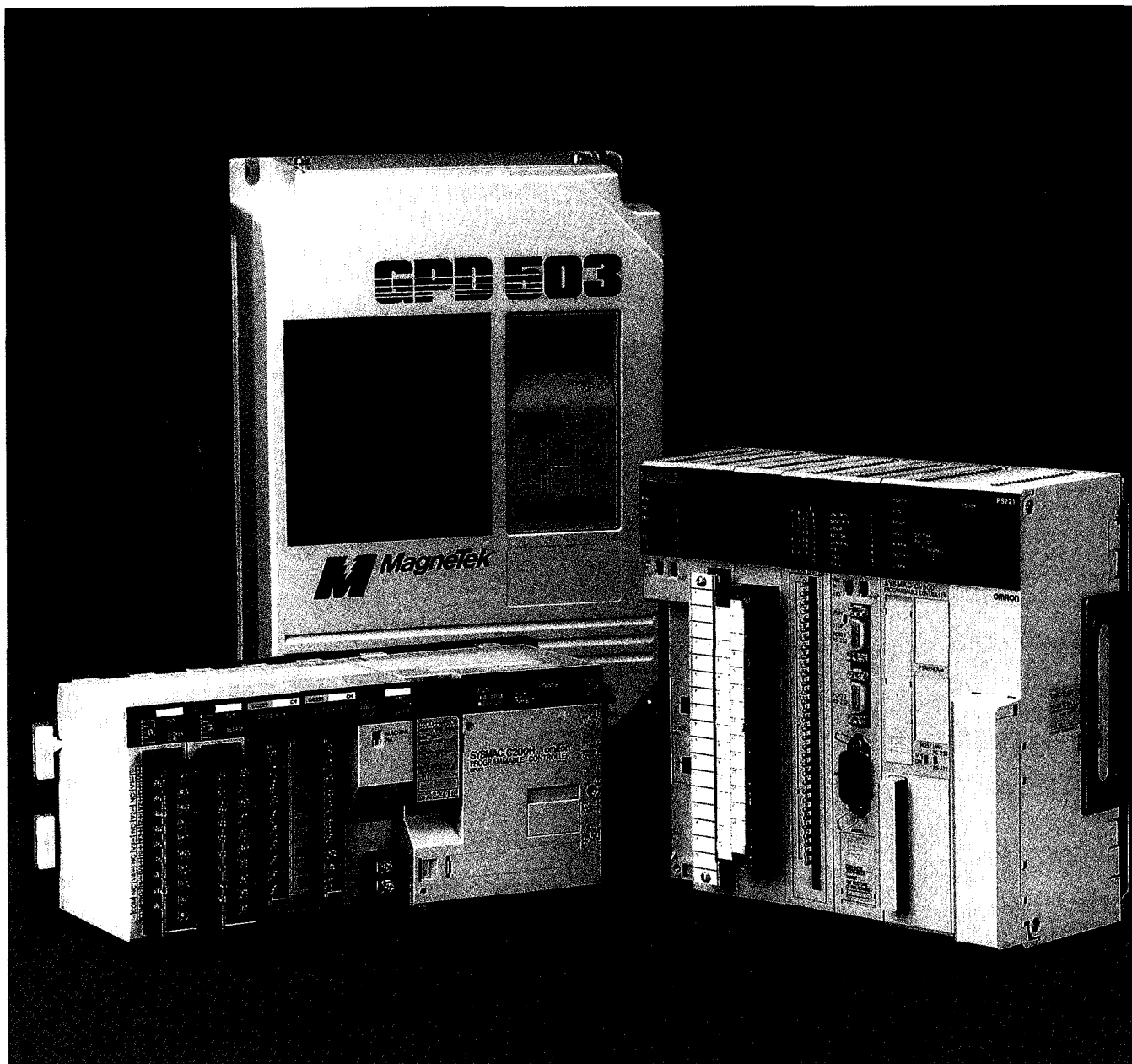

## **Addendum to TM 4024**

### **GPD 503 – SysBus & SysBus/2 Serial Communications**

On page 2 of this manual, the **Note** is changed to:

If drive EPROMs U5 and U6 are numbered in the NSG615XXX series, replace them with the EPROMs which came in this kit. Otherwise, leave the existing EPROM chips in the drive.

## **Notice:**

Magnetek products are manufactured for use according to proper procedures by a qualified operator and only for the purposes described in this manual.

The following conventions are used to indicate and classify warnings in this manual. Always heed the information provided with them.

**Caution** Indicates information that, if not heeded, could result in minor injury or damage to the product.

**DANGER!** Indicates information that, if not heeded, could result in loss of life or serious injury.

## **Visual Aids**

The following headings appear in the left column of the manual to help you locate different types of information.

**Note** Indicates information of particular interest for efficient and convenient operation of the product.

**1, 2, 3...** 1. Indicates lists of one sort or another, such as procedures, checklists, etc.

### © **MagneTek, 1993**

All rights reserved. No part of this publication may be reproduced, stored in a retrieval system, or transmitted, in any form, or by any means, mechanical, electronic, photocopying, recording, or otherwise, without the prior written permission of MagneTek.

No patent liability is assumed with respect to the use of the information contained herein. Moreover, because MagneTek is constantly striving to improve its high-quality products, the information contained in this manual is subject to change without notice. Every precaution has been taken in the preparation of this manual. Nevertheless, MagneTek assumes no responsibility for errors or omissions. Neither is any liability assumed for damages resulting from the use of the information contained in this publication.

# Record of Changes - TM 4024

1993 ..... Original Printing.  
03/07/94 ..... Added Addendum (concerning EPROM note on page 2).  
06/29/94 ..... Correction of Program Example on page 79.

# TABLE OF CONTENTS

## SECTION 1

<b>Features and System Configuration</b> .....	<b>1</b>
1-1 Features .....	3
1-2 System Configuration .....	4
1-3 Setting .....	6
1-4 Modifying Data with the Digital Operator .....	8

## SECTION 2

<b>Wired SYSMAC BUS System Setup</b> .....	<b>9</b>
2-1 Nomenclature and Settings .....	10
2-2 Setting Word Numbers .....	10
2-3 Installation and Wiring .....	15
2-4 Powering Up .....	17

## SECTION 3

<b>Optical SYSMAC BUS System/2 Setup</b> .....	<b>19</b>
3-1 Nomenclature and Settings .....	20
3-2 Setting Word Numbers .....	20
3-3 Installation and Wiring .....	22
3-4 Powering Up .....	24

## SECTION 4

<b>Data Setting and Operation</b> .....	<b>27</b>
4-1 Communicating with PLCs .....	28
4-2 Word Allocation .....	32
4-3 GPD 503 Operation Reference and External Inputs Relationship .....	37
4-4 Master Frequency References and External Inputs Relationship .....	38

## SECTION 5

<b>Communicating with PLCs</b> .....	<b>43</b>
5-1 Writing Data .....	42
5-2 Data Reading (Monitoring) .....	47
5-3 Precautions when Writing or Reading Data .....	48
5-4 Transmission Delay Time .....	49

## SECTION 6

<b>Error Processing</b> .....	<b>53</b>
6-1 Data Setting Errors .....	52
6-2 GPD 503 AC Drive Operations When Transmission Error Occurs .....	53

**SECTION 7**

**Data Code Charts ..... 57**

- 7-1 Converting Set Values to Hexidecimals ..... 56
- 7-2 System Constant Sn-\_\_ ..... 57
- 7-3 Control Constant Cn-\_\_ ..... 62
- 7-4 Frequency References An-\_\_ ..... 65
- 7-5 Changing Constants during Operation bn-\_\_ ..... 66
- 7-6 ENTER Command ..... 66
- 7-7 Frequency References ..... 67
- 7-8 Monitor Display Un-\_\_ ..... 68
- 7-9 Fault Content Monitoring ..... 69
- 7-10 Monitoring Data Link Status ..... 70

**SECTION 8**

**Program Examples ..... 73**

- 8-1 Program Example 1 ..... 72
- 8-2 Program Example 2 ..... 74

**Index ..... 83**

## ***About this Manual:***

This manual describes the installation and operation of the **GPD 503 AC Drive Interface Card** and includes the sections described below.

Please read this manual completely and be sure you understand the information provided before attempting to install and operate the **GPD 503**.

**Section 1** describes the features and system configuration of the GPD 503 AC Drive and explains the settings necessary for each system configuration.

**Section 2** describes the procedures for setting up the wired OMRON SYSMAC BUS system, setting word numbering and powering up the system.

**Section 3** describes the procedures used for setting up the Fiber-optic SYSMAC BUS system, setting word numbering and powering up the system.

**Section 4** describes the GPD 503 AC Drive's data communications features, including data setting options, multifunction command capabilities and the relationship between external inputs and both master and operation references.

**Section 5** describes how the GPD 503 AC Drive communicates with PLC's, programming to read and write data and what precautions to take when performing these operations.

**Section 6** describes the GPD 503 AC Drive unit's error processing features and how the unit operates when an error occurs.

**Section 7** provides the user with the data codes required in operating the GPD 503 AC Drive.

**Section 8** provides programming examples for the GPD 503 AC Drive. Two examples are provided, one for operation in which one code is changed and the second for cases in which two or more codes must be changed.

# SECTION 1

## Features and System Configuration

This section describes the features and system configuration of the GPD 503 AC Drive and explains the settings necessary for each system configuration.

1-1	Features .....	3
1-2	System Configuration .....	4
1-2-1	OMRON SYSMAC BUS Wired System .....	4
1-2-2	Fiber-optic OMRON SYSMAC BUS/2 System .....	5
1-3	Setting Function Additions .....	6
1-3-1	Display Function Additions .....	7
1-4	Modifying Data with the Digital Operator .....	8



## Important Points

### OMRON SYSMAC BUS, OMRON SYSMAC BUS/2 Compatibility

When using a general-purpose GPD 503 in connection with an OMRON SYSMAC BUS Wired System or an OMRON SYSMAC BUS/2 Fiber-optic System, be sure to check which GPD 503 model is being used. The only models that can be connected to OMRON SYSMAC BUS or BUS/2 by installing an SCB-BUS/2 or SCB-BUS Interface Card are versions that have U5 and U6 EPROM numbers **NSG615285H** and **NSG615285L** installed respectively.

**Note** If drive EPROMs, U5 and U6, are respectively part numbered NSG615145H and NSG615145L, or lower, replace them with the EPROMs provided with this kit. Otherwise, leave the existing EPROMs in the drive.

## Abbreviations

The following abbreviations are used in this manual.

GPD 503 AC Drive: GPD 503 General-purpose Drives with U5 and U6 EPROM numbers NSG615285H and NSG615285L.

PLC: OMRON SYSMAC C- or CV-series Programmable Controllers that can be linked with the OMRON SYSMAC BUS or SYSMAC BUS/2 Systems

SCB-BUS: OMRON SYSMAC BUS Wired Remote I/O Interface Card

SCB-BUS/2: OMRON SYSMAC BUS/2 Fiber-optic Remote I/O Interface Card

Sn-\_\_: System constant

Cn-\_\_: Control constant

An-\_\_: Frequency reference constant

bn-\_\_: Constant to change during operation

Un-\_\_: Monitor display constant

## Reference Manuals

Name	Manual No.
GPD 503 AC Drive Technical Manual	TM 4231
OMRON SYSMAC BUS Wired Remote I/O System Manual	W120
OMRON SYSMAC BUS/2 System Manual	W204

## 1-1 Features

The GPD 503 SCB-BUS (for OMRON SYSMAC BUS Wired) and the GPD 503 SCB-BUS/2 (for OMRON SYSMAC BUS/2 Fiber-optic) are dedicated communications interface cards which make it possible for the GPD 503 AC Drive to communicate with OMRON SYSMAC Programmable Controllers. Installing one of these interface cards in the GPD 503 AC Drive permits a Programmable Controller to monitor RUN/STOP and operating conditions, and to make changes in set values.

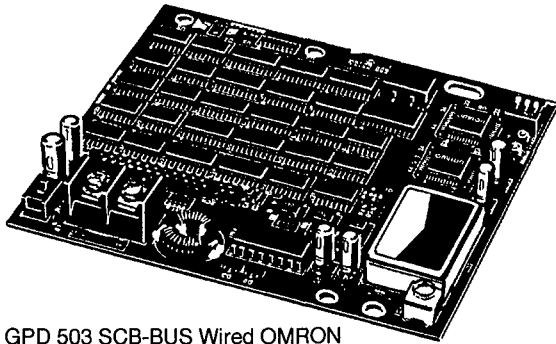

GPD 503 SCB-BUS Wired OMRON SYSMAC BUS Interface Card

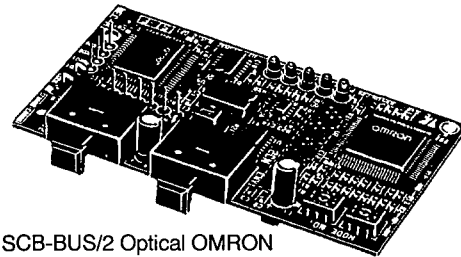

GPD 503 SCB-BUS/2 Optical OMRON SYSMAC BUS/2 Interface Card

### Choice of Communications Methods

Depending on your system requirements, you can select either a Wired OMRON SYSMAC BUS or Fiber-optic OMRON SYSMAC BUS/2 Remote I/O System for communications with OMRON SYSMAC Programmable Controllers. Wired OMRON SYSMAC BUS uses a 2-conductor cable to simplify system wiring, whereas the Fiber-optic OMRON SYSMAC BUS/2 uses fiber-optic technology to facilitate high-speed communications over extended distances.

### Program-less Data Exchange

Communications between a Programmable Controller and the GPD 503 AC Drive take place within four words of the PLC's IR area, so no special communications program is required. For data communications to be executed automatically, it is only necessary to set the data and the codes for reading and writing in the fixed data area.

### Communications with OMRON SYSMAC C/CV-series PLCs

OMRON SYSMAC BUS Wired Remote I/O Systems can be used with either OMRON SYSMAC C-series or CV-series Programmable Controllers.

C-series: C200H, C120, C500, C1000H, and C2000H

CV-series: CV500 and CV1000

OMRON SYSMAC BUS/2 Fiber-optic Remote I/O Systems can only be used with OMRON SYSMAC CV-series Programmable Controllers (CV500 and CV1000)

### Ample Monitoring Capability

Fifteen kinds of readouts, including during operation, zero speed, and up-to frequency setting, are possible for operating status monitoring. In addition, operating condition monitoring provides a picture of load shift conditions such as output frequency, output current, and output voltage. The contents of the four most recent error items are saved in memory, thus facilitating troubleshooting and correction in the event that an error should occur.

## 1-2 System Configuration

### 1-2-1 OMRON SYSMAC BUS Wired System

When a GPD 503 SCB-BUS Interface Card is installed, the GPD 503 AC Drive can communicate with Programmable Controllers through 2-wire cable.

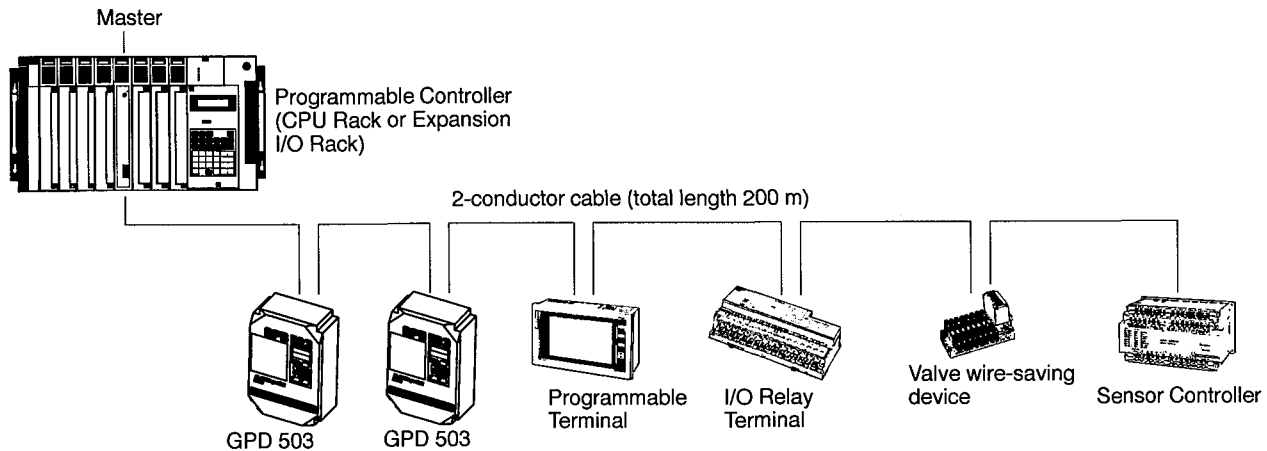

#### Number of Connectible Inverters

OMRON SYSMAC CPU Rack	Master	No. of Inverters per Master	No. of Inverters per CPU Rack	OMRON SYSMAC BUS I/O points per CPU Rack
C200H	C200H-RM201	8 max. (32 words)	8 max.	512 max. (32 words: 200 to 231)
C120	C500-RM201	4 max. (16 words)	4 max.	256 max. (16 words)
C500		8 max. (32 words)	8 max.	512 max. (32 words)
C1000H		32 max. (4 Masters)	2,048 max. (128 words)	
C2000H				
C2000		8 max.	512 max. (32 words)	
CV500				
CV1000				16 max. (2 Masters)

**Note** A single GPD 503 AC Drive uses four I/O words.

#### Communications Specifications

Item	Specifications
Transmission path	2-conductor cable (VCTF0.75 x 2C recommended)
Transmission speed	187.5 kbps
Transmission distance	200 m (total)
Communications method	Two-wire system, half duplex
Synchronization method	Start/stop synchronization

### 1-2-2 Fiber-optic OMRON SYSMAC BUS/2 System

When a GPD 503 SCB-BUS/2 Interface Card is installed, the GPD 503 AC Drive can communicate with CV500 and CV1000 Programmable Controllers at high speed over long distances, through a fiber-optic cable.

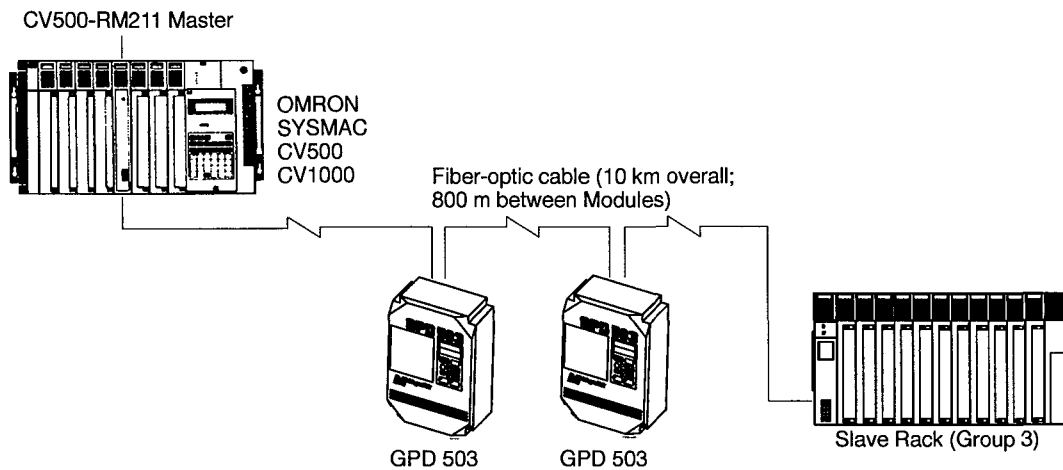

#### Number of Inverter Connections

OMRON SYSMAC CPU Rack	Master	No. of Drives per CPU Rack	No. of OMRON SYSMAC BUS/2 I/O points
CV500	CV500-RM211	16 max.	1,024 max. (64 words)
CV1000		32 max.	2,048 max. (128 words)

- Note**
1. A single GPD 503 AC Drive uses four I/O words.
  2. The GPD 503 AC Drive is treated as a Group 1 Slave.

#### Communications Specifications

Item	Specifications
Communications method	1:N polling/selection method
Synchronization method	Start/stop synchronization
Transmission method	Time-division multiple, cyclic + event method
Transmission speed	1.5 Mbps
Transmission distance	Between Modules: 800 m; overall: 10 km
Topology	Daisy chain/loop
Transmission medium	2-wire fiber-optic cable (hard plastic-clad quartz fiber)
No. of connecting nodes	32 max.
Sign method	Manchester coding
Modulation method	Base band
Error control system	CRC-CCITT
RAS function	Transmission path duplication; double address check
Transmission contents	Cyclic: 128 words max. Event: 552 bytes max.

### 1-3 Setting

The GPD 503 with OMRON communication EPROM's installed has the additional parameters shown below for OMRON SYSMAC BUS and OMRON SYSMAC BUS/2 communications. Drives other than these cannot communicate through OMRON SYSMAC BUS and OMRON SYSMAC BUS/2.

#### Setting Data Additions

Data no.	Data name	Bit no.	Setting Data	Function	Initial setting (HEX)	Reference
Sn-08	RUN Mode Selection	1st bit	0	Operates by option card frequency references (when comm card is installed).	0100 (0004)	Section 4-4
			1	Operates by inverter frequency references.		
		2nd bit	0	Operates by option card frequency references (when comm card is installed).		Section 4-3
			1	Operates by inverter frequency references.		
		3rd bit	Transmission error processing selection (when comm card is installed). 00: Ramp stop (deceleration time 1: bn-02) 01: Coasting stop 10: Ramp stop (deceleration time 2: bn-04) 11: Operation continued			Section 6-2
		4th bit				

#### Communication Command Additions

##### Frequency References

Data Code		Data						Reference
Read (HEX)	Write (HEX)	Data name	Setting unit	Setting range	Initial value	Setting range input data	Initial setting (HEX)	
65	E5	Frequency reference	0.01 Hz	0.00 to 400.00	0.00	0000 to 9C40	0000	Section 7-7
	E6	Frequency reference (width)	0.01 Hz	0.00 to 400.00	0.00	0000 to 9C40	0000	

The data code sets the frequency directly from a Programmable Controller. For writing frequency references, it is not necessary to write an ENTER command. An-\_\_ is used for multi-speed operations according to multi-step speed commands.

##### ENTER Command

Data Code		Data			Reference
Read (HEX)	Write (HEX)	Data name	Data range	Data range (HEX conversion)	
—	FD	ENTER command	0000	0000	Section 7-6 Section 5-1

When setting or modifying drive constants Sn-\_\_, Cn-\_\_, An-\_\_, and bn-\_\_ by means of write processing, be sure to add the ENTER command data at the end.

Monitoring Operations

Data Code		Data			Reference
Read (HEX)	Write (HEX)	Data name	Data range	Description	
67	—	Drive Status	16-bit data	GPD 503 operating status (operating, zero speed, etc.) can be monitored through bit ON/OFF status.	Section 7-8 Section 7-9 Section 7-10 Section 4-1
68	—	Error Content	16-bit data (4 x 4 bits)	The content of the past four GPD 503 errors (over-current, over-voltage, etc.) can be monitored.	
69	—	Data Link Status	16-bit data	The error content of communication data can be monitored through bit ON/OFF status.	

Frequency, current, etc., can be monitored by Un-\_\_.

1-3-1 Display Function Additions

Displays During Transmission Errors

If an transmission error should occur during OMRON SYSMAC BUS or OMRON SYSMAC BUS/2 communications, the display on the Digital Operator will be as shown below.

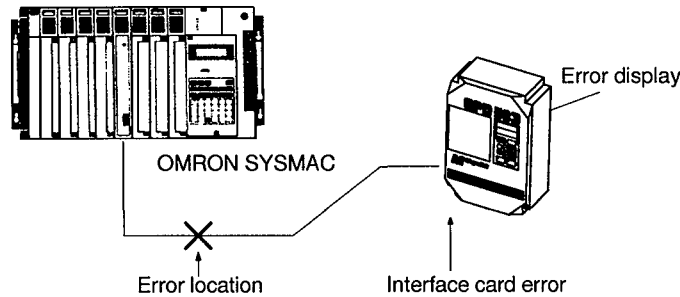

Display	Name	Contents
E-15	Transmission Path Error	There is an error in the transmission path. Check the transmission path.
E-10	Interface Card Error	There is an error in the interface card. Turn off the power to the GPD 503 AC Drive, and then turn it on again. If the error persists, replace the card.

Display While Waiting for Communication Data Code

From the time that OMRON SYSMAC BUS or OMRON SYSMAC BUS/2 communications begins until the time that the data is successfully transmitted, the display on the Digital Operator will be as shown below.

Display	Name	Contents
CALL	Communication Data Code Waiting	After the interface card has been installed and the GPD 503 AC Drive has been powered up, the GPD 503 will display "CALL" and go to waiting status if either of the following conditions applies: 1) Transmission has not occurred. 2) There is a transmission error, and the data code has not been transmitted.

- Note**
1. If Sn-08 = xx11 (operation by inverter frequency or operation reference), CALL will not be displayed.
  2. If only the operation reference bits of word *n* (bits 15 to 08) turn ON and OFF, the CALL display will not be cleared.

## 1-4 Modifying Data with the Digital Operator

It is possible to modify data with the Digital Operator when the GPD 503 AC Drive is used for OMRON SYSMAC BUS or OMRON SYSMAC BUS/2 communications.

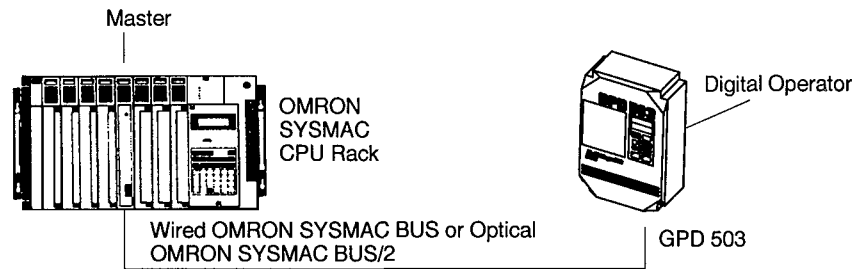

- Note**
1. Do not modify data with the Digital Operator while data is being written or read by means of communications.
  2. After modifying data with the Digital Operator, be sure to put the GPD 503 AC Drive in DRIVE Mode. It cannot operate in PRGM (Program) Mode.

# SECTION 2

## Wired SYSMAC BUS System Setup

This section describes the procedures for setting up the wired OMRON SYSMAC BUS system, setting word numbering and powering up the system.

2-1	Nomenclature and Settings .....	10
2-2	Setting Word Numbers .....	10
2-2-1	System Configuration Example .....	11
2-2-2	Switches and Words Occupied Relationship .....	11
2-2-3	Word Number Setting Example .....	13
2-3	Installation and Wiring .....	15
2-3-1	Installing and Mounting .....	15
2-3-2	Internal Wiring .....	16
2-3-3	System Wiring .....	16
2-4	Powering Up .....	17



## 2-1 Nomenclature and Settings

### Nomenclature

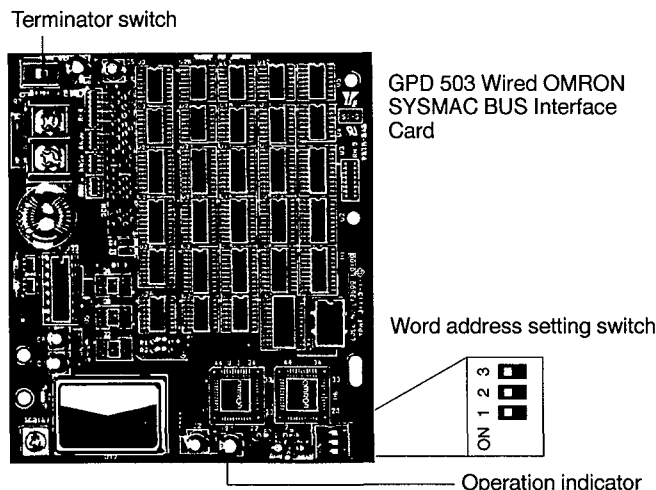

### Terminator Switch

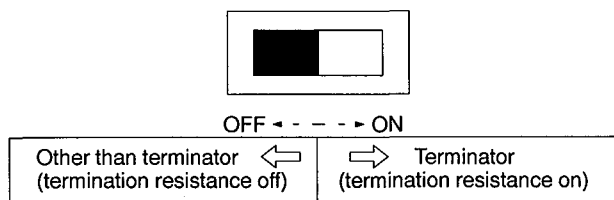

The terminator switch also serves as the termination resistance switch. Set this switch to ON for the Module connected farthest in line from the Master. (The terminator switch is factory set to OFF.)

### Operation Indicator

Display		Function
RUN (green)	Lit	Lit when power is on and PLC is in RUN or Monitor Mode.
	Not lit	Transmission error or when PLC is in Program Mode.
T/R ERR Transmitting/Error (red)	Blinking	Blinks during normal transmission.
	Lit	Lit while waiting or at time of transmission error.
	Not lit	Off at time of communications CPU error (watchdog timer monitoring error).

**Word Number Setting Switch** With the settings for switches 1 to 3, the GPD 503 AC Drive will occupy four words (from n to n+3) as a Slave.

Switch no.			Words occupied				Switch no.			Words occupied			
1 (2 <sup>0</sup> )	2 (2 <sup>1</sup> )	3 (2 <sup>2</sup> )	n	n+1	n+2	n+3	1 (2 <sup>0</sup> )	2 (2 <sup>1</sup> )	3 (2 <sup>2</sup> )	n	n+1	n+2	n+3
OFF	OFF	OFF	0	1	2	3	OFF	OFF	ON	16	17	18	19
ON	OFF	OFF	4	5	6	7	ON	OFF	ON	20	21	22	23
OFF	ON	OFF	8	9	10	11	OFF	ON	ON	24	25	26	27
ON	ON	OFF	12	13	14	15	ON	ON	ON	28	29	30	31

## 2-2 Setting Word Numbers

Each GPD 503 AC Drive occupies four Programmable Controller I/O words. Set the words with the word number setting switches on the Wired OMRON SYSMAC BUS Interface Card. Be careful not to overlap GPD 503 AC Drive word numbers with the word numbers occupied by other Slaves.

### 2-2-1 System Configuration Example

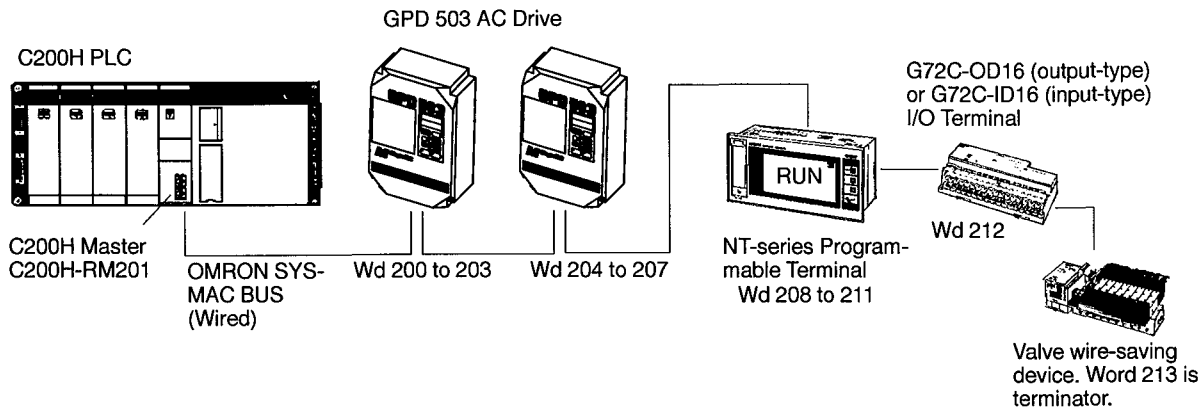

**Number of Words Occupied**

GPD 503 AC Drive:	4
Programmable Terminal:	4
I/O Terminal:	1
Valve wire-saving device:	1

### 2-2-2 Switches and Words Occupied Relationship

The correlation between switches and the words they occupy are summarized in the following tables.

#### C200H

Switch no.			Words occupied				Switch no.			Words occupied			
1	2	3	n	n+1	n+2	n+3	1	2	3	n	n+1	n+2	n+3
OFF	OFF	OFF	200	201	202	203	OFF	OFF	ON	216	217	218	219
ON	OFF	OFF	204	205	206	207	ON	OFF	ON	220	221	222	223
OFF	ON	OFF	208	209	210	211	OFF	ON	ON	224	225	226	227
ON	ON	OFF	212	213	214	215	ON	ON	ON	228	229	230	231

#### C120/C500

Switch no.			Words occupied				Switch no.			Words occupied			
1	2	3	n	n+1	n+2	n+3	1	2	3	n	n+1	n+2	n+3
OFF	OFF	OFF	0	1	2	3	OFF	OFF	ON	16	17	18	19
ON	OFF	OFF	4	5	6	7	ON	OFF	ON	20	21	22	23
OFF	ON	OFF	8	9	10	11	OFF	ON	ON	24	25	26	27
ON	ON	OFF	12	13	14	15	ON	ON	ON	28	29	30	31

C1000H/C2000(H)

Switch no.			Base no. 0				Base no. 1				Base no. 2				Base no. 3			
1	2	3	n	n+1	n+2	n+3	n	n+1	n+2	n+3	n	n+1	n+2	n+3	n	n+1	n+2	n+3
OFF	OFF	OFF	0	1	2	3	32	33	34	35	64	65	66	67	96	97	98	99
ON	OFF	OFF	4	5	6	7	36	37	38	39	68	69	70	71	100	101	102	103
OFF	ON	OFF	8	9	10	11	40	41	42	43	72	73	74	75	104	105	106	107
ON	ON	OFF	12	13	14	15	44	45	46	47	76	77	78	79	108	109	110	111
OFF	OFF	ON	16	17	18	19	48	49	50	51	80	81	82	83	112	113	114	115
ON	OFF	ON	20	21	22	23	52	53	54	55	84	85	86	87	116	117	118	119
OFF	ON	ON	24	25	26	27	56	57	58	59	88	89	90	91	120	121	122	123
ON	ON	ON	28	29	30	31	60	61	62	63	92	93	94	95	124	125	126	127

CV500/CV1000

In the OMRON SYSMAC BUS Remote I/O Relay Area of CV500 and CV1000 Programmable Controllers, each Master (#0 to #7) is allocated 32 words, beginning with word 2300, as the default (initial value).

Master address	RM0	RM1	RM2	RM3	RM4	RM5	RM6	RM7
Words allocated	2300 to 2331	2332 to 2363	2364 to 2395	2396 to 2427	2428 to 2459	2460 to 2491	2492 to 2523	2524 to 2555

Master addresses

Master addresses are assigned automatically, in the order in which the Masters are mounted (including the setting order of Rack numbers), at the time of I/O table creation or I/O table editing. For the CV500, addresses are only allocated for Masters #0 to #3 (words 2300 to 2427).

Switch no.			RM0				RM1				RM2			
1	2	3	n	n+1	n+2	n+3	n	n+1	n+2	n+3	n	n+1	n+2	n+3
OFF	OFF	OFF	2300	2301	2302	2303	2332	2333	2334	2335	2364	2365	2366	2367
ON	OFF	OFF	2304	2305	2306	2307	2336	2337	2338	2339	2368	2369	2370	2371
OFF	ON	OFF	2308	2309	2310	2311	2340	2341	2342	2343	2372	2373	2374	2375
ON	ON	OFF	2312	2313	2314	2315	2344	2345	2346	2347	2376	2377	2378	2379
OFF	OFF	ON	2316	2317	2318	2319	2348	2349	2350	2351	2380	2381	2382	2383
ON	OFF	ON	2320	2321	2322	2323	2352	2353	2354	2355	2384	2385	2386	2387
OFF	ON	ON	2324	2325	2326	2327	2356	2357	2358	2359	2388	2389	2390	2391
ON	ON	ON	2328	2329	2330	2331	2360	2361	2362	2363	2392	2393	2394	2395

Switch no.			RM3				RM4				RM5			
1	2	3	n	n+1	n+2	n+3	n	n+1	n+2	n+3	n	n+1	n+2	n+3
OFF	OFF	OFF	2396	2397	2398	2399	2428	2429	2430	2431	2460	2461	2462	2463
ON	OFF	OFF	2400	2401	2402	2403	2432	2433	2434	2435	2464	2465	2466	2467
OFF	ON	OFF	2404	2405	2406	2407	2436	2437	2438	2439	2468	2469	2470	2471
ON	ON	OFF	2408	2409	2410	2411	2440	2441	2442	2443	2472	2473	2474	2475
OFF	OFF	ON	2412	2413	2414	2415	2444	2445	2446	2447	2476	2477	2478	2479
ON	OFF	ON	2416	2417	2418	2419	2448	2449	2450	2451	2480	2481	2482	2483
OFF	ON	ON	2420	2421	2422	2423	2452	2453	2454	2455	2484	2485	2486	2487
ON	ON	ON	2424	2425	2426	2427	2456	2457	2458	2459	2488	2489	2490	2491

Switch no.			RM6				RM7			
1	2	3	n	n+1	n+2	n+3	n	n+1	n+2	n+3
OFF	OFF	OFF	2492	2493	2494	2495	2524	2525	2526	2527
ON	OFF	OFF	2496	2497	2498	2499	2528	2529	2530	2531
OFF	ON	OFF	2500	2501	2502	2503	2532	2533	2534	2535
ON	ON	OFF	2504	2505	2506	2507	2536	2537	2538	2539
OFF	OFF	ON	2508	2509	2510	2511	2540	2541	2542	2543
ON	OFF	ON	2512	2513	2514	2515	2544	2545	2546	2547
OFF	ON	ON	2516	2517	2518	2519	2548	2549	2550	2551
ON	ON	ON	2520	2521	2522	2523	2552	2553	2554	2555

### 2-2-3 Word Number Setting Example

Setting word numbers is shown in the following illustrations. Settings for the C200H, C120/C500, C1000H/C2000H, and CV500/CV1000 system configurations are provided.

#### C200H

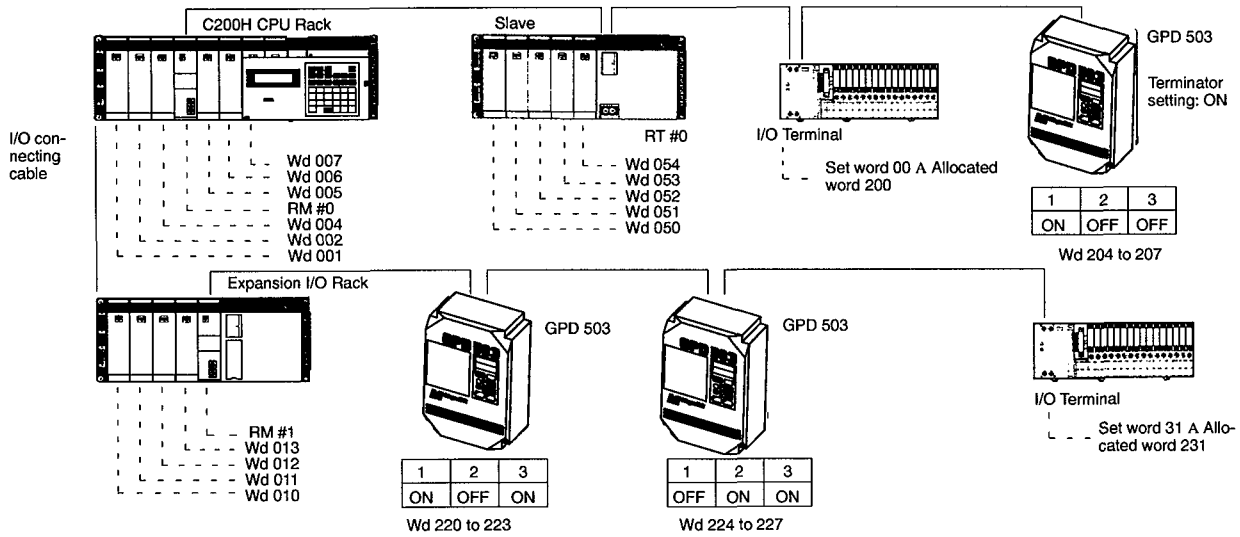

C-120/C500

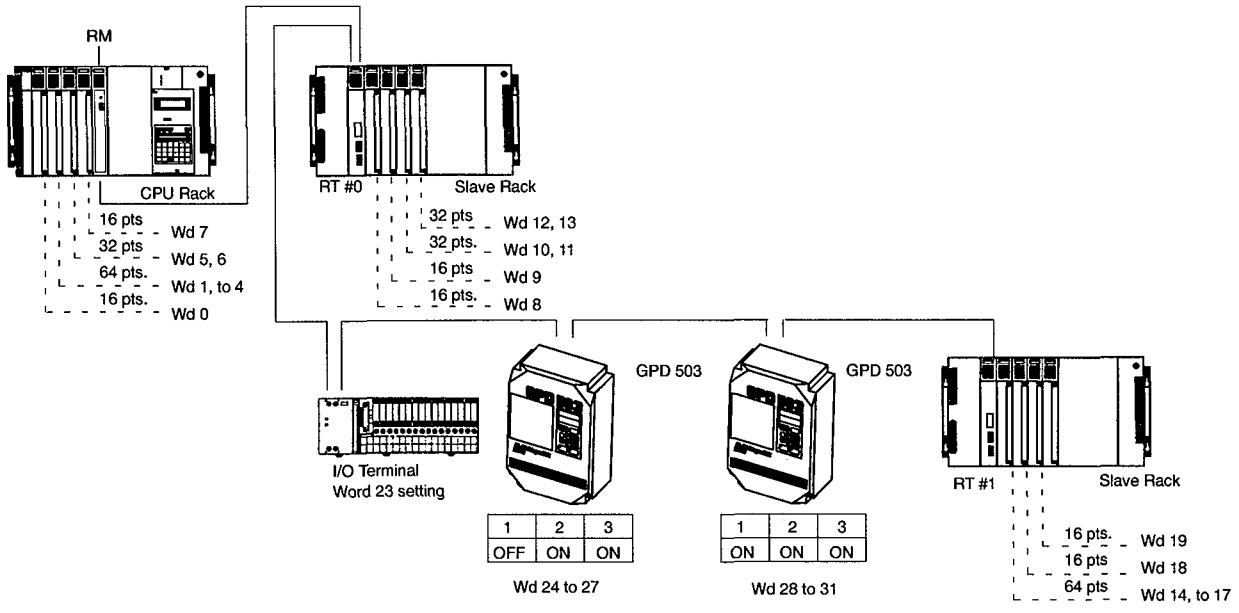

C1000H/C2000H

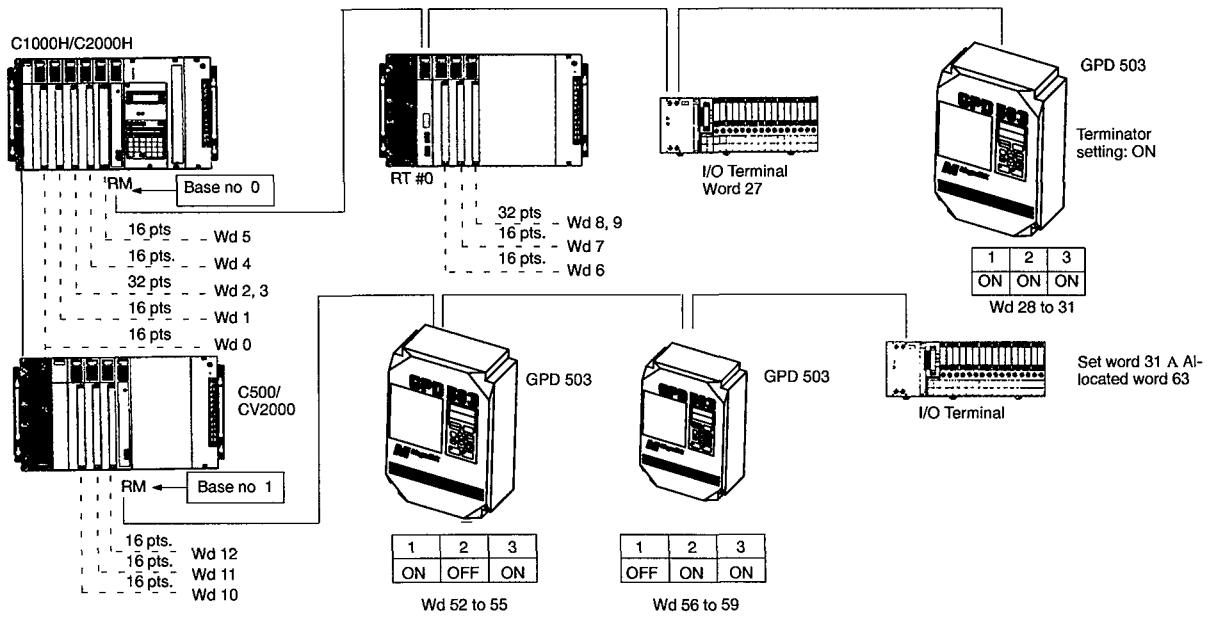

CV500/CV1000

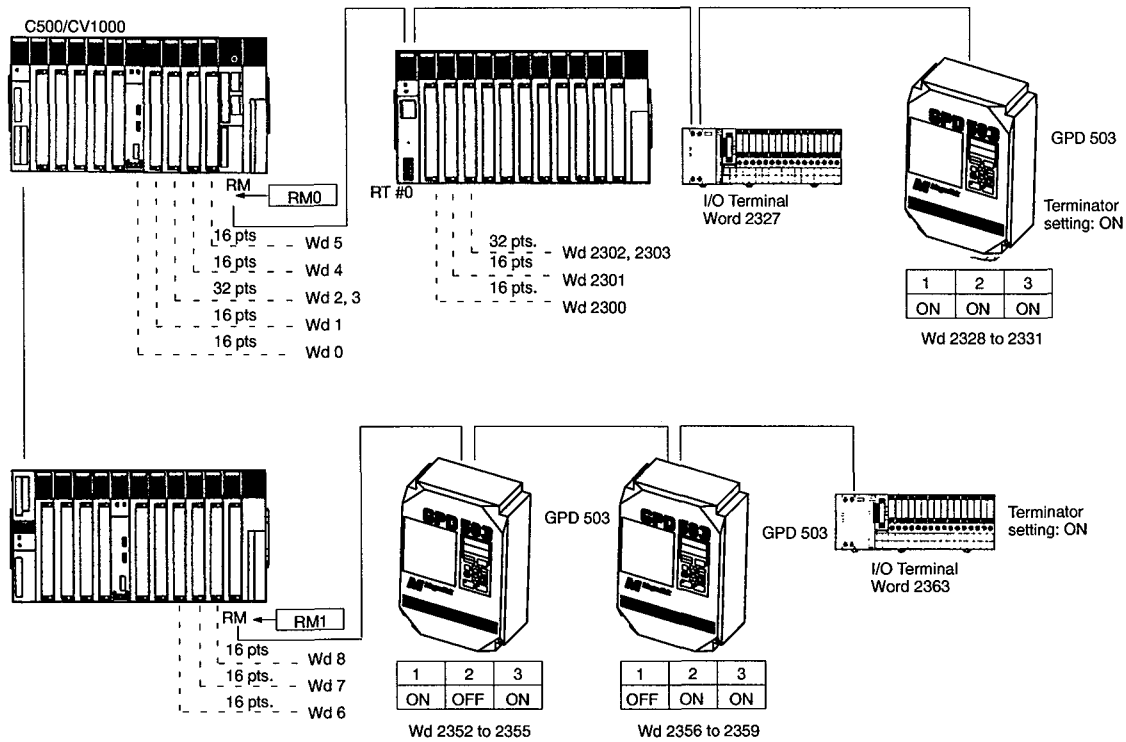

## 2-3 Installation and Wiring

When installing and wiring a OMRON SYSMAC BUS Interface Card, be sure to first turn off the power to the GPD 503 AC Drive and wait for the CHARGE lamp to turn off.

### 2-3-1 Installing and Mounting

#### Mounting Position

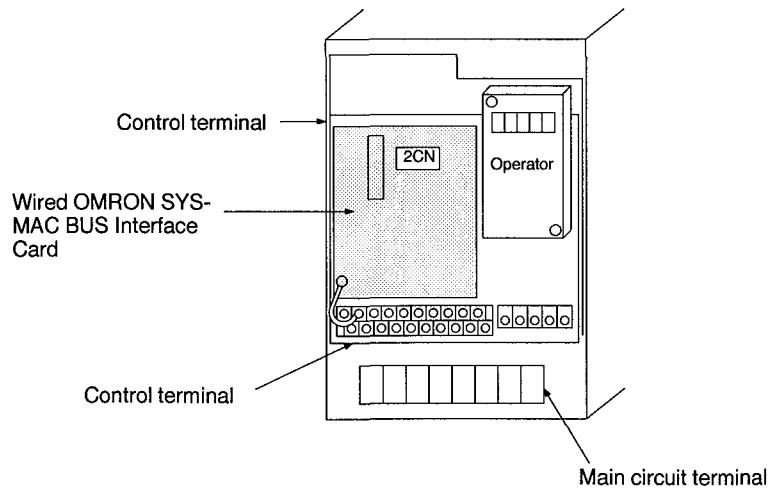

**Note** If an OMRON SYSMAC BUS Interface Card is installed, no other monitor option card can be installed. (3CN terminal slot cannot be used.)

**Mounting Method**

Mount the 2CN connector on the Interface Card to the 2CN connector (60 pins) on the GPD 503 AC Drive speed (frequency) command card. Hold the Interface Card in position over the three option card supports, and snap it securely into place.

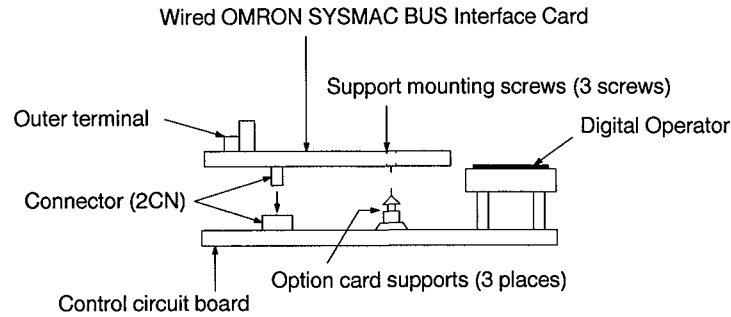

**2-3-2 Internal Wiring**

Keep the OMRON SYSMAC BUS wiring separated from the main circuit wiring as much as possible. Do not wire them together.

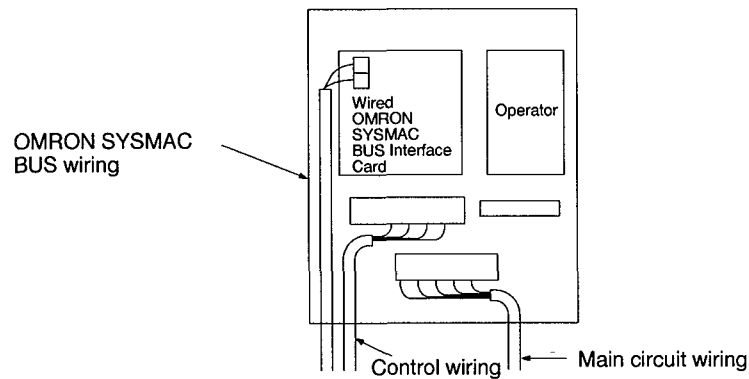

Pass the OMRON SYSMAC BUS wiring through the left side of the Interface Card.

**2-3-3 System Wiring**

When wiring a OMRON SYSMAC BUS Wired System, wire the Masters in order from the Programmable Controller with 2-conductor cable.

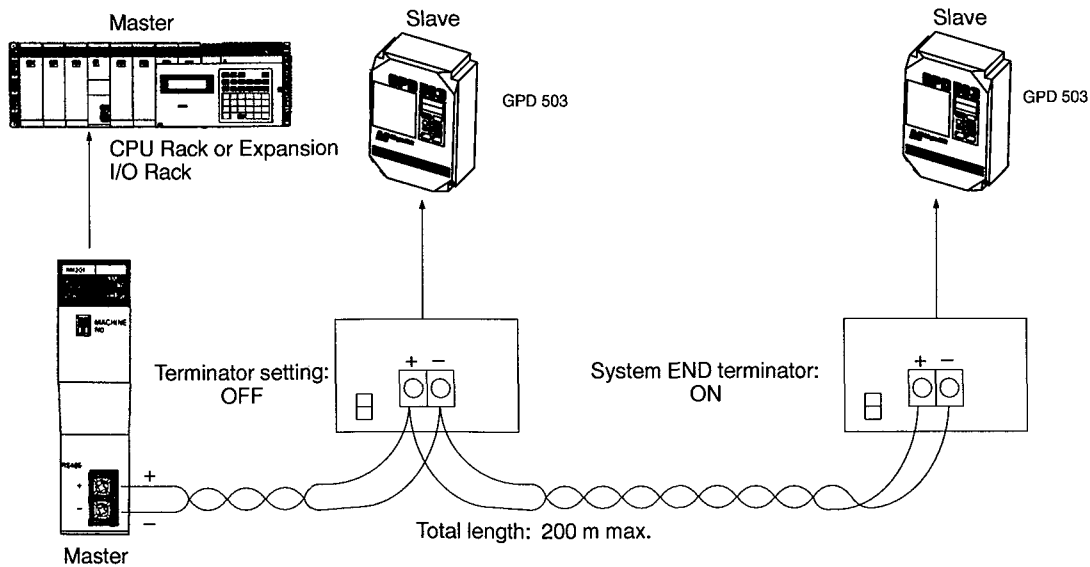

- 1, 2, 3... 1. Use 0.75 mm<sup>2</sup> x 2C VCTF (vinyl cabtire cable) for Wired OMRON SYSMAC BUS Systems.
2. When connecting terminals, be sure to connect plus to plus and minus to minus.
3. Wire the Slaves in order from the Master, and set the last one as the terminator.
4. The maximum overall cable length is 200 meters.
5. It is all right to mix ordinary I/O wiring with power lines, but do not place high-voltage lines or lines with strong current in close proximity to, or parallel with, the GPD 503 AC Drive output wiring.

**Note** Do not overlap word numbers for Slaves.

**Slave Connections**

Wire C500 and C200H Masters to Slaves as shown below.

RM: Master

RS: Slave or Slave Rack (including GPD 503 SCB-BUS Interface Card)

**Correct Connection Example**

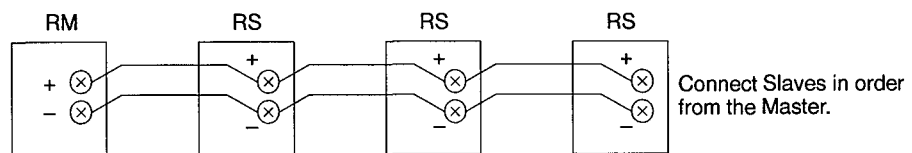

**Incorrect Connection Examples**

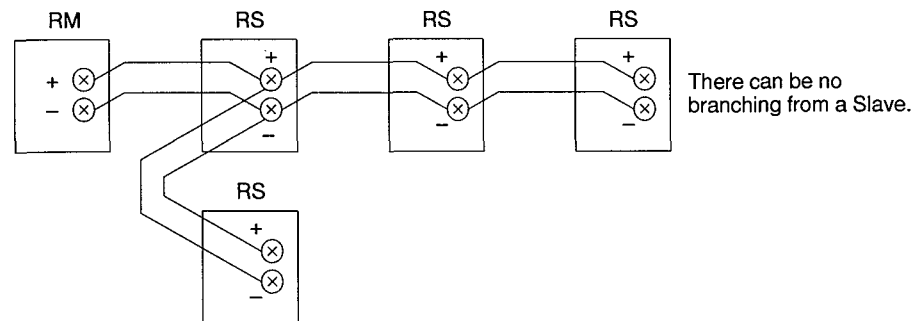
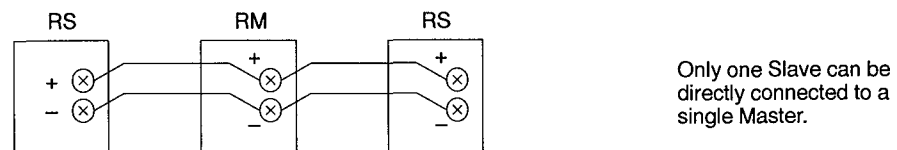

**2-4 Powering Up**

- 1, 2, 3... 1. Turn on the power to the GPD 503 AC Drive and the other Slaves.
2. Turn on the power at the CPU Rack where the Master is mounted.
3. Create the I/O table at the Programmable Controller. For C1000H and C2000(H) PLCs, set the base numbers.
4. Confirm reception.

While the GPD 503 AC Drive is waiting for Inverter data codes, the Digital Operator will display CALL.



When the data codes are successfully received, the display will change from CALL to F00.00 (frequency reference display), and the GPD 503 AC Drive will be ready for operation.

**Note** Start up the System with the GPD 503 AC Drive in DRIVE Mode. (The GPD 503 AC Drive is in DRIVE Mode when it is powered up.)

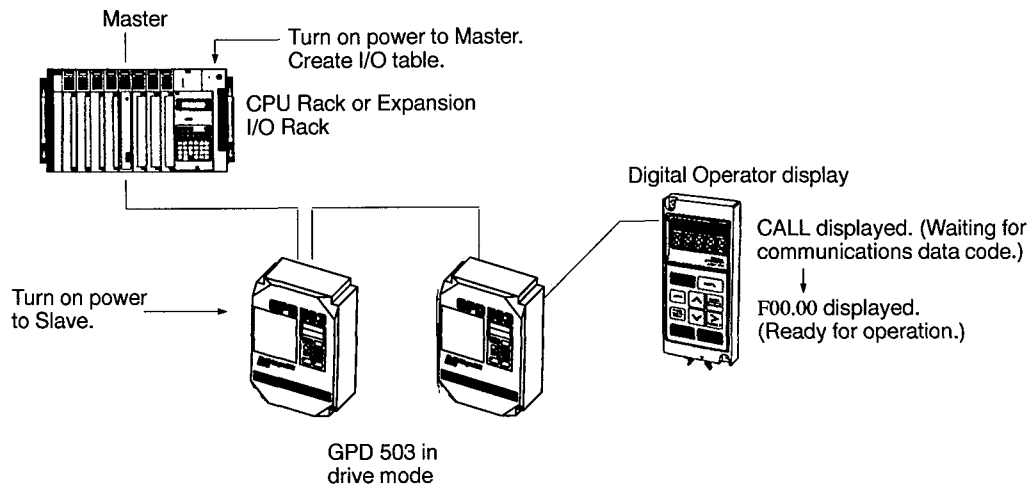

# SECTION 3

## Fiber-optic OMRON SYSMAC BUS System/2 Setup

This section describes the procedures used for setting up the OMRON SYSMAC BUS/2 Fiber-optic System, setting word numbering and powering up the system.

3-1	Nomenclature and Settings .....	20
3-2	Setting Word Numbers .....	20
3-2-1	Number of Connectable Inverters (for CV-Series) .....	20
3-2-2	CV-Series I/O Points .....	21
3-2-3	Address Numbers and Occupied Words Relationship .....	21
3-2-4	CV500/CV1000 Word Setting Example .....	22
3-3	Installation and Wiring .....	22
3-3-1	Installing .....	22
3-3-2	Internal Wiring .....	23
3-3-3	System Wiring .....	24
3-4	Powering Up .....	24

### 3-1 Nomenclature and Settings

#### Nomenclature

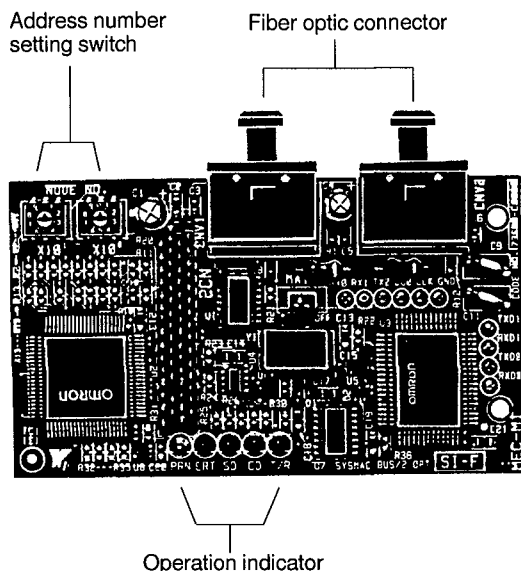

#### Operation Indicators

Indicator	Name	Status	Meaning
PRN (green)	Host User Monitor	Lit	Transmission is normal and the PLC is in RUN or Monitor Mode.
		Not lit	There is a transmission error or the PLC is in Program Mode.
ERT (red)	Transmission Error Monitor	Lit	There is a transmission error.
		Not lit	Transmission is normal.
SD (orange)	Transmit Data Monitor	Lit	Resident data is being transmitted.
		Not lit	Resident data transmission has stopped.
CD (orange)	Receive Data Monitor	Lit	Data is being received.
		Not lit	Data reception has stopped.
T/R (orange)	Data Transmission Status Monitor	Lit	Data transmission or reception is being executed.
		Not lit	Data transmission or reception is stopped or finished.

#### Address Number Setting Switch

Address numbers are set in order, from no.s 00 to 31, with a 2-digit BCD rotary switch. Set the addresses such that the numbers do not overlap.

### 3-2 Setting Word Numbers

#### 3-2-1 Number of Connectable GPD 503 Drives (for CV-Series)

In the CV500 and CV1000, I/O bits, OMRON SYSMAC BUS/2 remote I/O bits, and OMRON SYSMAC BUS remote I/O bits are all allocated independently. When both fiber-optic OMRON SYSMAC BUS/2 and Wired OMRON SYSMAC BUS communications are used simultaneously with the CV1000, the maximum total number of drives that can be connected is 48.

System Configuration

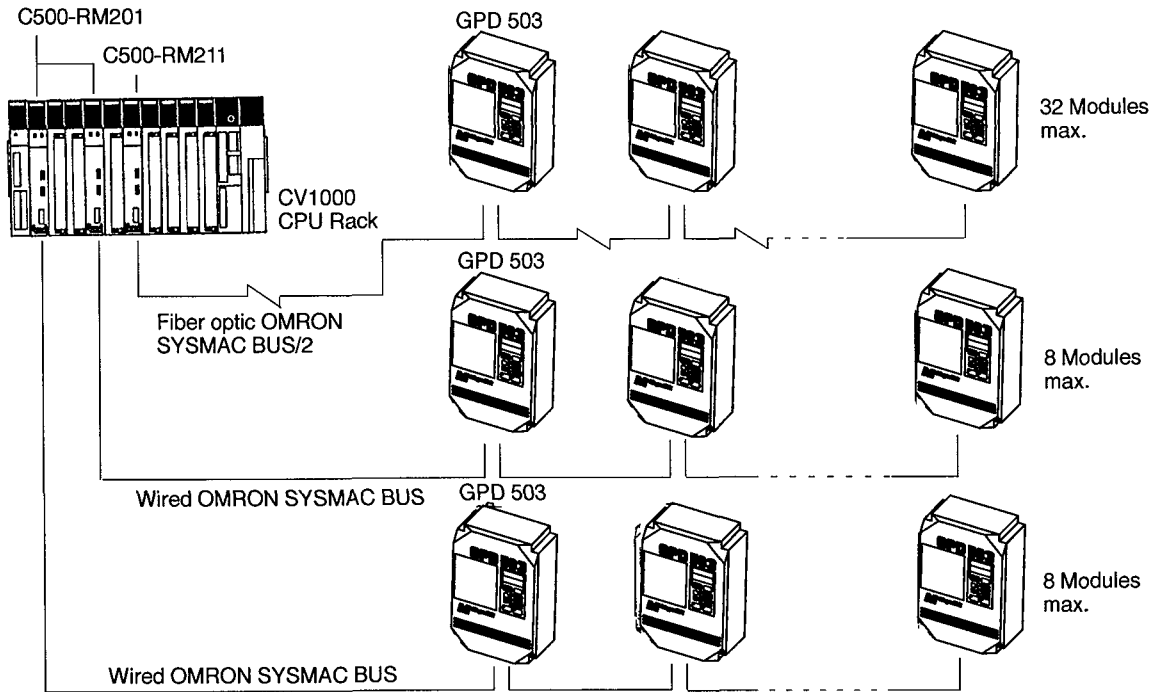

3-2-2 CV-Series I/O Points

		CPU Rack I/O Processing Points	
		CV500	CV1000
(1)	Total number of I/O points for Modules mounted to CPU Racks, Expansion CPU Racks, and Expansion I/O Racks.	512 max. (Words 0000 to 0031)	1,024 max. (Words 0000 to 0063)
(2)	Total number of I/O points for OMRON SYSMAC BUS/2 Slave Racks.	1,024 max. (Words 0200 to 0599)	2,048 max. (Words 0200 to 0999)
(3)	Total number of I/O points for OMRON SYSMAC BUS Slave Racks.	512 max. (Words 2300 to 2427)	1,024 max. (Words 2300 to 2555)

3-2-3 Address Numbers and Occupied Words Relationship

In the OMRON SYSMAC BUS/2 Remote I/O Relay Area of CV500 and CV1000 Programmable Controllers, each Master (Masters nos. 0 to 3) is allocated 200 words, beginning with word 200, as the default initial value.

Master address	Group 1	Group 2	Group 3
RM0	0200 to 0249	0250 to 0299	0300 to 0399
RM1	0400 to 0449	0450 to 0499	0500 to 0599
RM2	0600 to 0649	0650 to 0699	0700 to 0799
RM3	0800 to 0849	0850 to 0899	0900 to 0999

For the CV500, addresses are only allocated for Masters nos. 0 and 1 (words 0200 to 0599). For the CV1000, addresses are allocated for Masters nos. 0 to 3 (words 0200 to 0999).

The GPD 503 AC Drive is classified as a Group 1 Slave, and occupies four words. Master addresses are allocated automatically, at the time of I/O table

creation or I/O table editing, in the order in which the unit numbers have been set with the switches on the Masters, i.e., in order from nos. 0 to 15. Group 1 and Group 2 Slaves are allocated words in order, according to the address numbers that have been set on each Slave, beginning with the first word reserved for that group.

### 3-2-4 CV500/CV1000 Word Setting Example

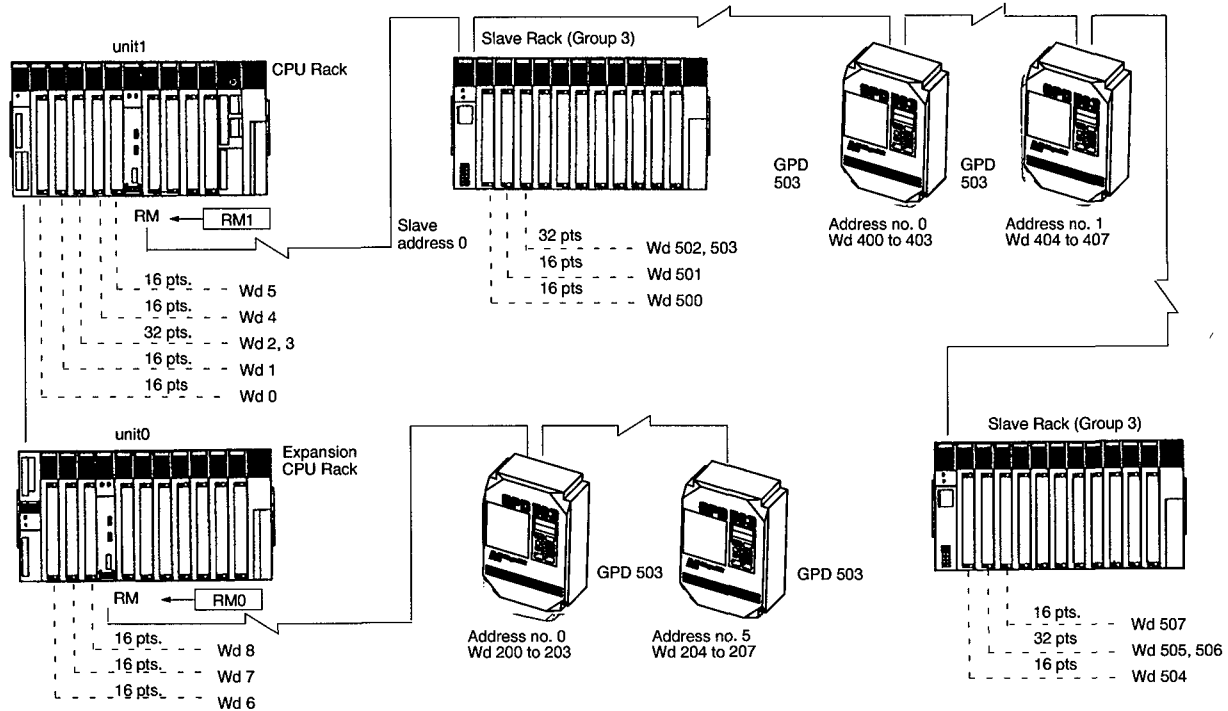

## 3-3 Installation and Wiring

When installing and wiring a OMRON SYSMAC BUS/2 Interface Card, be sure to first turn off the power to the GPD 503 AC Drive and wait for the CHARGE lamp to turn off.

### 3-3-1 Installing

#### Mounting Position

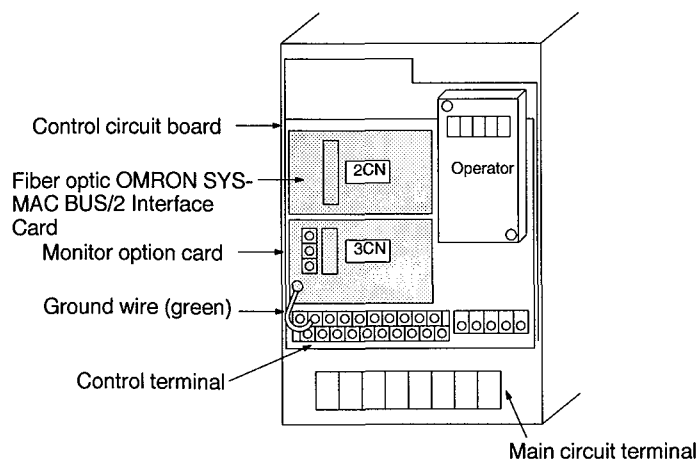

**Mounting Method**

Mount the 2CN connector on the Interface Card to the 2CN connector (60 pins) on the GPD 503 AC Drive speed (frequency) command card. Hold the Interface Card in position over the two option card supports, and snap it securely into place.

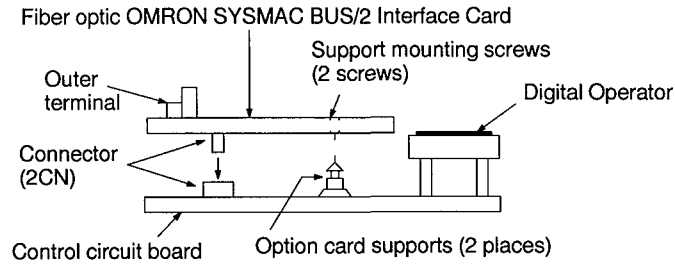

**3-3-2 Internal Wiring**

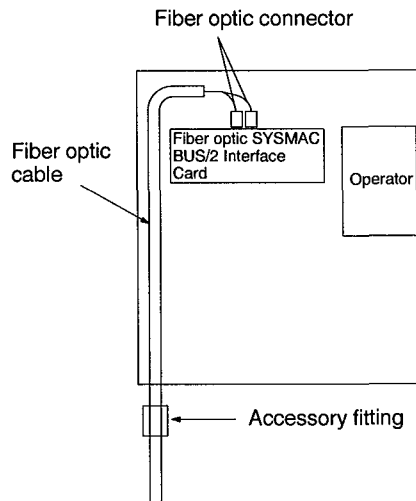

**Accessory Fittings**

Depending on your requirements, you can mount the drive in the panel or elsewhere and secure the fiber-optic cable.

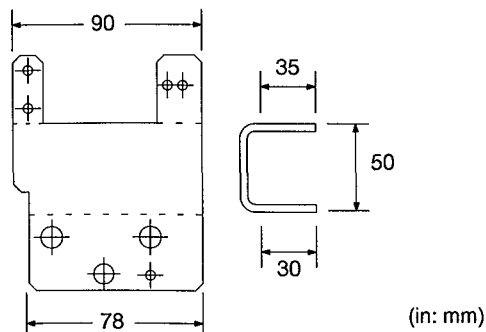

### 3-3-3 System Wiring

In a OMRON SYSMAC BUS/2 System, fiber-optic cable can be used for either a daisy chain or loop connection.

#### Daisy Chain Method

##### Normal Circuit Mode

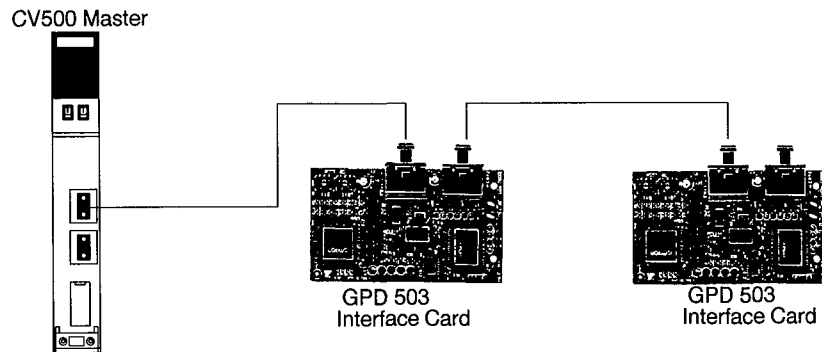

##### Sub-circuit Mode

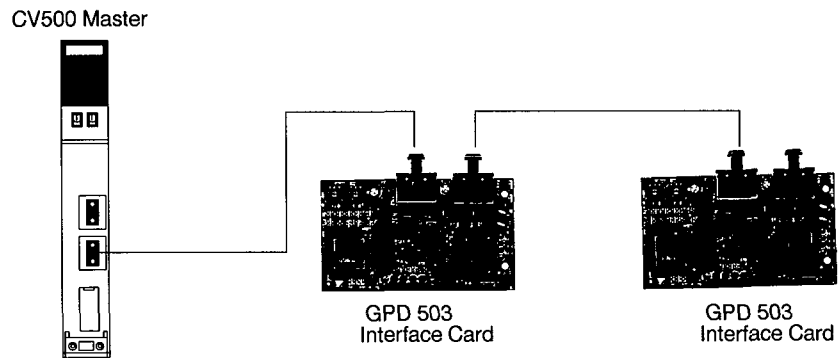

#### Loop System

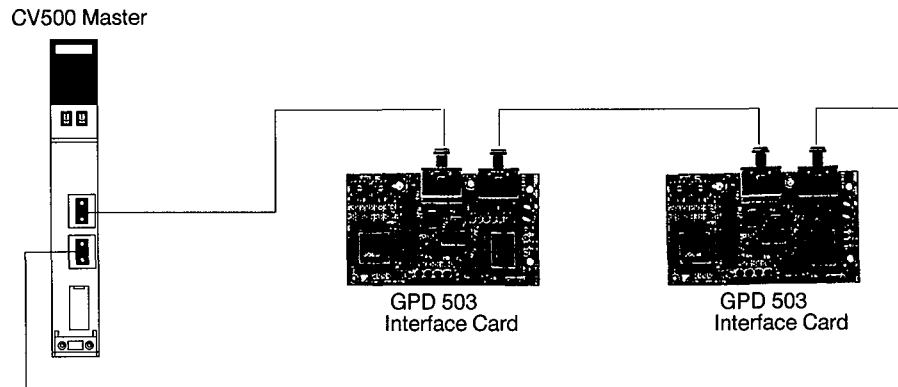

## 3-4 Powering Up

1, 2, 3...

1. Turn on the power to the GPD 503 AC Drive and the other Slaves.
2. Turn on the power at the CPU Rack where the Master is mounted.
3. Create the I/O table at the Programmable Controller.
4. Confirm reception.

While the GPD 503 AC Drive is waiting for drive data codes, the Digital Operator will display CALL.

When the data codes are successfully received, the display will change from CALL to F00.00, the frequency reference display, and the GPD 503 AC Drive will be ready for operation.

**Note** Start up the System with the GPD 503 AC Drive in DRIVE Mode. The GPD 503 AC Drive is in DRIVE Mode when it is powered up.

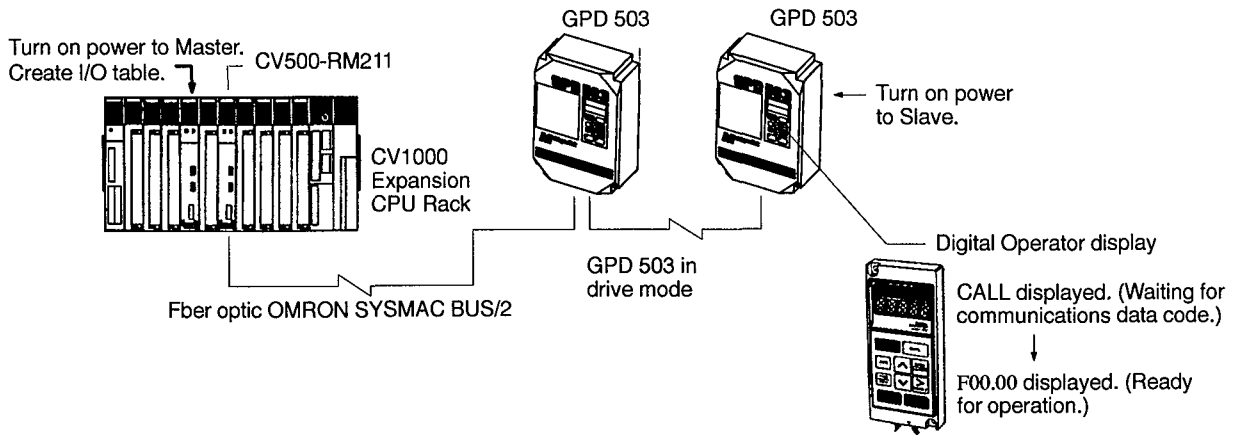





# SECTION 4

## Data Setting and Operation

This sections describes the GPD 503 AC Drive's data communications features, including data setting options, multifunction command capabilities and the relationship between external inputs and both master and operation references.

4-1	Communicating with PLCs .....	28
4-1-1	Words Occupied by GPD 503 AC Drive .....	28
4-1-2	Data Content .....	28
4-1-3	Data Writing .....	29
4-1-4	Data Reading .....	29
4-2	Word Allocation .....	32
4-2-1	Multi-function Commands (Multi-function Inputs) .....	33
4-2-2	Multi-function Outputs .....	35
4-3	Inverter Operation Reference and External Inputs Relationship .....	37
4-4	Master Frequency References and External Inputs Relationship .....	38
4-4-1	Multi-step Speed Operation .....	40

## 4-1 Communicating with PLCs

This section will provide a general outline of communications between the GPD 503 AC Drive and OMRON SYSMAC Programmable Controllers. For more detailed instructions, refer to section 5 Communicating with PLCs and section 8 Program Examples.

### 4-1-1 Words Occupied by GPD 503 AC Drive

GPD 503 AC Drives are treated as Group 1 Slaves in Wired OMRON SYSMAC BUS or fiber-optic OMRON SYSMAC BUS/2 Systems, and occupy four I/O words in the PLC.

Input/Output	Word address	Bit no.	
		08 to 15	00 to 07
Output PLC to GPD 503	n	Drive operation reference	Data code (setting)
	n+1	Write data	
Input GPD 503 to PLC	n+2	Drive status	Data code (return)
	n+3	Read data	

Words n to n+3 are set with the Word Number Setting Switch on the Interface Card.

### 4-1-2 Data Content

#### DriveOperation Reference (PLC to GPD 503)

The PLC sends commands to the GPD 503 AC Drive by turning bits ON and OFF.

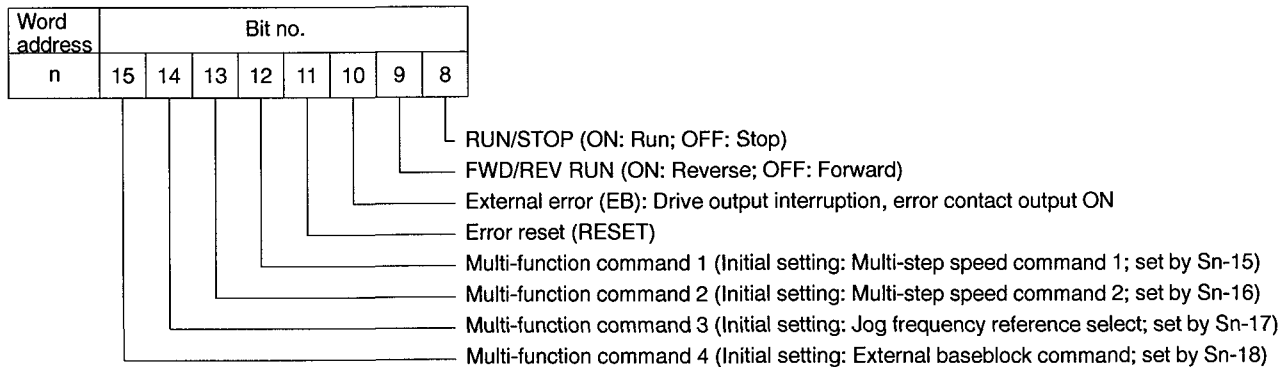

#### Drive Status (GPD 503 to PLC)

GPD 503 AC Drive operating conditions are sent to the PLC by the ON/OFF status of bits.

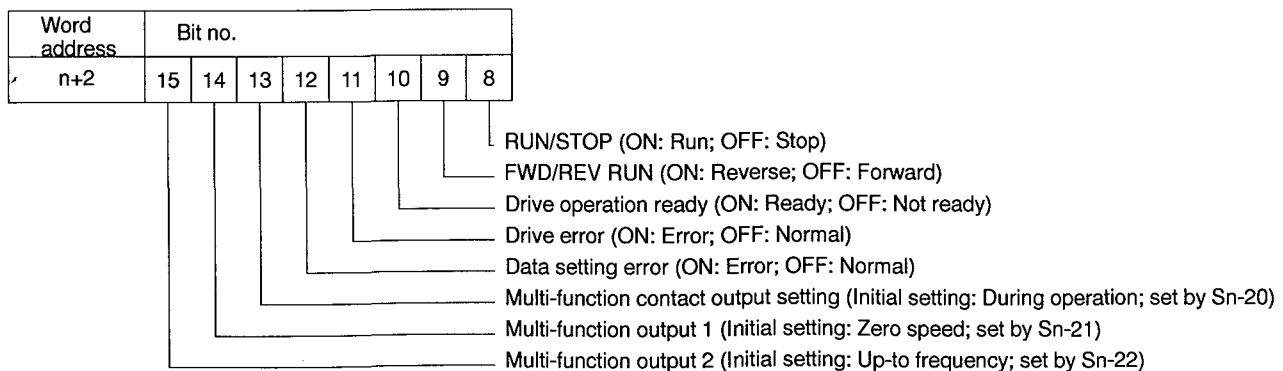

### 4-1-3 Data Writing

Set the data codes and the write data to be sent from the PLC to the GPD 503 AC Drive. The data codes and the write data are handled in hexadecimal.

Word address	Bit no.	
	08 to 15	00 to 07
n	Drive operation reference	Data code
n+1	Write data	

Example: Setting bn-01 (Acceleration Time 1) to 5.0 Seconds

Data Code			Data name	Setting unit
Read (HEX)	Write (HEX)	Data no.		
50	D0	bn-01	Acceleration Time 1	0.1 s

When 5.0 seconds is converted to hexadecimal, the setting unit is 0.1 second. Therefore,

$$5.0 \text{ s} = 50 * 0.1$$

↘  
32 (HEX) set as write data

#### Transmission Data

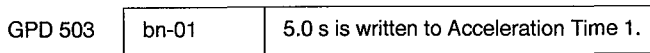
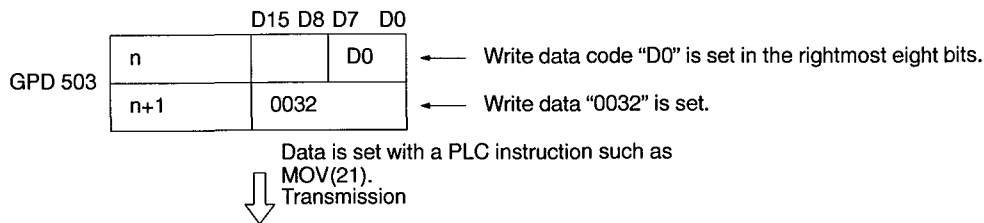

### 4-1-4 Data Reading

GPD 503 AC Drive data and operating conditions are read at the PLC. When the data code (read) allocated for monitoring is set in the PLC's word n, bits 00 to 07, the GPD 503 AC Drive data corresponding to the read data code is output to word n+3 in hexadecimal.

Example: Reading the bn-01 (Acceleration Time 1) Set Value

In this example, bn-01 data code (read) 50 is set in word n, bits 00 to 07, and the set value for bn-01 is thereby read into word n+3 in hexadecimal.

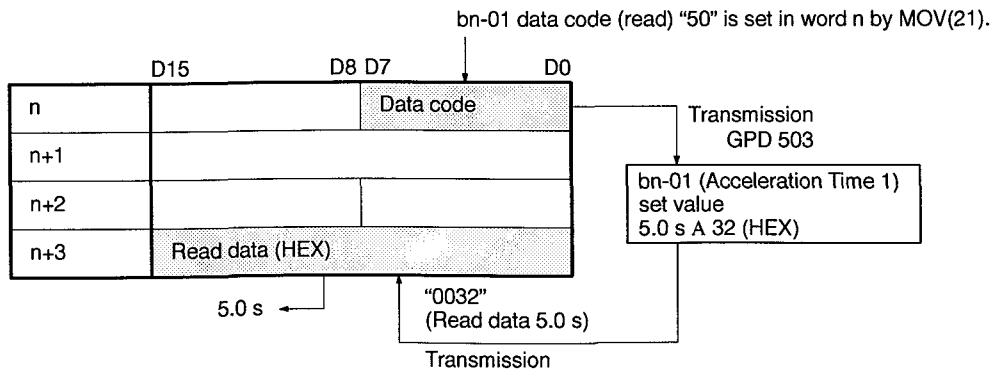

**Data Monitoring**

By setting the following data codes (read) into word n, bits 00 to 07, the corresponding data values can be monitored by word n+3 in hexadecimal.

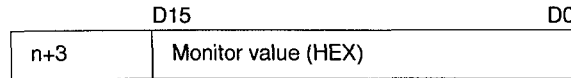

Data Code			Data name
Read (HEX)	Write (HEX)	Data no.	
5C	—	Un-01	Frequency reference
5D	—	Un-02	Output frequency
5E	—	Un-03	Output current
5F	—	Un-04	Output voltage
60	—	Un-05	DC voltage (VPN)
61	—	Un-06	Output power (+)
62	—	Un-07	Multi-function input terminal status
63	—	Un-08	Multi-function output terminal status

**Inverter Status Monitoring  
(Read Data Code 67)**

When data code 67 is set in word n, bits 00 to 07, the Drive Status Mode is read into word n+3.

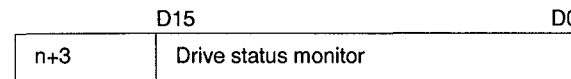

Bit no.	Function
D0	During operation
D1	Zero speed
D2	Up-to frequency setting
D3	Up-to desired frequency setting
D4	Frequency detection 1
D5	Frequency detection 2
D6	Drive operation ready
D7	During undervoltage detection
D8	During output interruption
D9	Frequency reference mode
D10	Operation reference mode
D11	Over-torque detection
D12	During frequency reference loss
D13	Control resistance deficiency
D14	Fault
D15	—

**Error Content Monitor  
(Read Data Code 68)**

When data code 68 is set in word n, bits 00 to 07, the contents of the four most recent errors are set in word n+3, in 4-bit units.

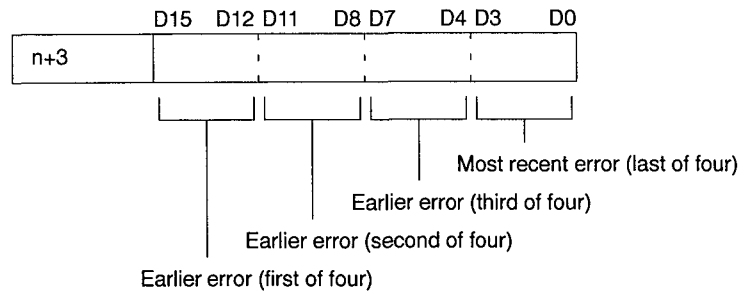

Drive Error is read when word n+2, bit 11 turns ON, and it is cleared when Error Reset is executed.

Data	Content
0000	No Fault
0001	Over-current (OC)
0010	Over-voltage (OV)
0011	Drive overload (OL2)
0100	Drive overheating (OH)
0101	—
0110	Fuse break (FU)
0111	Brake transistor fault, Resistor Overheat
1000	External fault (EFxx)
1001	Control circuit fault (CPFxx)
1010	Motor overload (OL1)
1011	—
1100	Power failure (including momentary interruptions) (UV1)
1101	—
1110	—
1111	—

**Data Link Status Monitor  
(Read Data Code 69)**

When data code 69 is set in word n, bits 00 to 07, the data link status (the content of data setting errors) is read into word n+3.

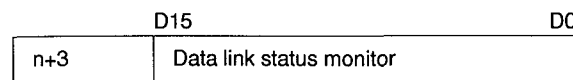

Bit no.	Function
D0	During data write processing
D1	Write mode error
D2	Data code error
D3	Setting range error A (Up/down limit error)
D4	Setting range error B (Adjustment error)
D5	NV-RAM write error
D6	ENTER command not received
D7 to D15	—

## 4-2 Word Allocation

Input/Output	Word address	Bit no.	Function
Output (PLC to GPD 503)	n	D0 to 7	Data code Sets data code for write or read data.
		D8	RUN/STOP (ON: Run; OFF: Stop)
		D9	FWD/REV RUN (ON: Reverse; OFF: Forward)
		D10	External error (EB)
		D11	Error Reset (RESET)
		D12	Multi-function command 1 (Initial setting: Multi-step speed command 1; set by Sn-15) (See note 1)
		D13	Multi-function command 2 (Initial setting: Multi-step speed command 2; set by Sn-16) (See note 1)
		D14	Multi-function command 3 (Initial setting: Jog frequency reference select; set by Sn-17) (See note 1)
		D15	Multi-function command 4 (Initial setting: External baseblock command; set by Sn-18) (See note 1)
	n+1	D0 to 15	Write data Sets write data. Setting not required for read data.
Input (GPD 503 to PLC)	n+2	D0 to 7	Data code A data code identical to that which is set in word n, bits 00 to 07, is returned to this area.
		D8	During operation (ON: Operating; OFF: Stopped)
		D9	FWD/REV RUN (ON: Reverse; OFF: Forward)
		D10	Drive operation ready (ON: Ready; OFF: Not ready) (See note 3)
		D11	Drive error (ON: Error; OFF: Normal)
		D12	Data setting error (ON: Error; OFF: Normal)
		D13	Multi-function contact output setting (Initial setting: Operating; set by Sn-20) (See note 2)
		D14	Multi-function output 1 (Initial setting: Zero speed; set by Sn-21) (See note 2)
	D15	Multi-function output 2 (Initial setting: Up-to frequency; set by Sn-22) (See note 2)	
	n+3	D0 to 15	Read data When read is executed, the data in the data code is read. When write is executed, the current write data is returned.

- Note**
1. For multi-function commands 1 to 4, the factory settings are as shown in the table. The contents of these settings can be changed by setting Sn-15 to Sn-18.
  2. For the multi-function outputs, the factory settings are as shown in the table. The contents of these settings can be changed by setting Sn-20 to Sn-22.
  3. Inverter Operation Ready (word n+2, bit 10)

The GPD 503 AC Drive uses this bit to inform the PLC of whether or not it is ready for operation. When this bit is OFF, the GPD 503 AC Drive will not operate even if it receives an operation command from the PLC. This bit is turned OFF when the GPD 503 AC Drive is placed in Program Mode by the Digital Operator, or until an ENTER command is received after write is executed for either system constant Sn or control constant Cn.

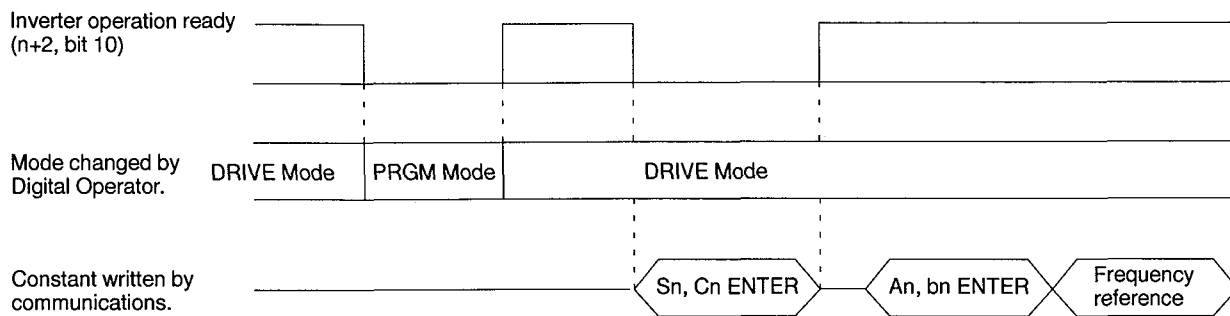

An, bn, and frequency references can be written even during operation.

### 4-2-1 Multi-function Commands (Multi-function Inputs)

For multi-function commands 1 to 4, the factory settings are as shown in the following table. The contents of these settings can be changed by setting Sn-15 to Sn-18.

Word address	Bit no.	Name	SYSDRIVE terminal nos.	Sn-__	Factory setting
n	D12	Multi-function command 1	(5) to (11)	Sn-15	0003 (Multi-step speed command 1)
	D13	Multi-function command 2	(6) to (11)	Sn-16	0004 (Multi-step speed command 2)
	D14	Multi-function command 3	(7) to (11)	Sn-17	0006 (Jog frequency reference select)
	D15	Multi-function command 4	(8) to (11)	Sn-18	0008 (NO-contact external baseblock command)

Multi-function commands 1 to 4 perform the same functions as the multi-function inputs of GPD 503 AC Drive terminals 5 to 8. There is a logical OR relationship between multi-function commands to the GPD 503 AC Drive from the PLC and multi-function input commands from the GPD 503 AC Drive terminals.

The contents of Sn-15 to Sn-18 settings can be changed by the Digital Operator or by data transmission from the PLC. They cannot be changed, however, while the GPD 503 AC Drive is being operated.

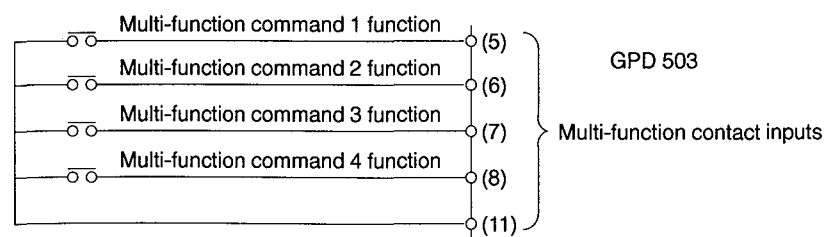

- Note**
- Sn-15 to Sn-18 settings are subject to the following constraints.  
Be sure to make the settings in order, from the smallest set value to the largest, for Sn-15 to Sn-18.
  - If there is a mistake in a setting, OPE3 (setting defect) will be generated.



Functions that Can be Set for Multi-function Commands

Set value	Function	Signal level	Remarks
0000	FWD/REV RUN select	OFF: Forward run; ON: Reverse run 3-wire sequence mode (00 set in Sn-15 ) Terminal 1: Run; 2: Stop; 5: FWD/REV selection	Enabled only when operated by external terminals.
0001	Operation signal select	OFF: Operated according to setting of digits 1 and 2 of Sn-04. ON: Operated by run/stop signal from keypad.	Enabled only when operated by Drive.
0002	Option/Inverter reference select	OFF: Operated by frequency or operation reference from option card. ON: Operated by frequency or operation reference from Inverter.	—
0003	Multi-step speed command 1	Frequency reference switchover	With these four signals, operation is possible with up to nine levels of speed.
0004	Multi-step speed command 2		
0005	Multi-step speed command 3		
0006	Jog frequency reference select		
0007	Accel/decel time select	OFF: Accelerates/decelerates with bn-01 and bn-02. ON: Accelerates/decelerates with bn-03 and bn-04.	—
0008	External baseblock (NO-contact input)	ON: Drive output is shut off. (Frequency reference is held.)	Coasts to stop during input.
0009	External baseblock (NC-contact input)	OFF: Drive output is shut off. (Frequency reference is held.)	
000A	Not used	—	—
000B			
000C	Multi-function analog input enabled	ON: Multi-function analog input enabled (terminal 16) OFF: Multi-function analog input disabled (terminal 16)	—
000D to 001F	Not used	—	—
0020 to 002F	External fault 1	Fault signal input from outside	Only "error stop" or "alarm message" can be selected.
0030 to 003F	External fault 2		
0040 to 004F	Not used	—	—
0050 to 005F			
0060			
0061	Search 1	ON: Search from maximum frequency.	Used for application power supply and switchover operations.
0062	Not used	—	—
0063	Energy-saving operation	ON: Energy-saving	Output voltage reduced to % of bn-08 set value.
0064 to 006F	Not used	—	—

## 4-2-2 Multi-function Outputs

The multi-function contact output and multi-function outputs 1 and 2 are factory set to during operation, zero speed, and up-to frequency, respectively. The output contents can be changed by settings in Sn-20 to Sn-22.

Word address	Bit no.	Name	SYSDRIVE terminal nos.		Sn-__	Factory setting
n+2	D13	Multi-function contact output	(9) to (10)	Contact output	Sn-21	0000 (During operation)
	D14	Multi-function output 1	(25) to (27)	Open-collector output	Sn-22	0001 (Zero-speed signal)
	D15	Multi-function output 2	(26) to (27)		Sn-20	0002 (Up-to frequency)

The contents of the multi-function contact output and multi-function outputs 1 and 2 are the same as that of the GPD 503 AC Drive multi-function outputs 9 to 10 and 25 to 27.

The settings of Sn-20 to Sn-22 can be changed by data communications from the Digital Operator or the PLC. Changes cannot be made, however, during GPD 503 AC Drive operation.

Multi-function output contents (set values 0000 to 000F) can all be read with the data read function. When reading data, use data code (read) 67 drive status for monitoring.

## Functions that Can be Set for Multi-function Outputs

Set value	Description		Remarks
	Name	Signal level	
0000	During operation	ON: During operation	Same as "during operation" of word n+2, bit 8.
0001	Zero speed	ON: Zero speed	On when output frequency is 0 Hz.
0002	Up-to frequency setting	ON: $(\text{Frequency ref} - \text{Cn-22}) \leq \text{Output frequency} \leq (\text{Frequency ref} + \text{Cn-22})$	Cn-21: Up-to frequency (speed) point Cn-22: The output signals shown in the illustration below are output according to the up-to frequency (speed) detection width setting.
0003	Up-to desired frequency setting	ON: Up-to speed status of set value 2 $(\text{Cn-21} - \text{Cn-22}) \leq \text{Output frequency} \leq (\text{Cn-21} + \text{Cn-22})$	
0004	Frequency detection 1	ON: Output frequency $\leq \text{Cn-21}$	
0005	Frequency detection 2	ON: Output frequency $\geq \text{Cn-21}$	
0006	Drive operation ready	ON: Drive operation ready	Same as "Drive operation ready" of word n+2, bit 10.
0007	During undervoltage detection	ON: During undervoltage detection	Operator display: UV
0008	During baseblock	ON: During Drive output baseblock	ON when there is no output to motor.
0009	Frequency reference mode	OFF: During operation by frequency reference from communications (when Interface Card is installed). ON: During operation by frequency reference from Drive.	When no Interface Card is installed OFF: During operation by frequency reference from external terminals. ON: During operation by frequency reference from operator.
000A	Operation reference mode	OFF: During operation by operation reference from communications (when Interface Card is installed). ON: During operation by operation reference from Drive.	When no Interface Card is installed OFF: During operation by operation reference from external terminals. ON: During operation by operation reference from operator.
000B	Over-torque detection	ON: During over-torque detection	Sn-07 setting required. Operator display: OL3.
000C	Not used	—	—
000D	Braking resistor fault	ON: During braking resistor overheating or braking resistor fault.	Operator display: rH
000E	Fault	ON: Fault (except CPF00, CPF01)	Same as "Drive fault" of word n+2, bit 11.
000F	Not used		

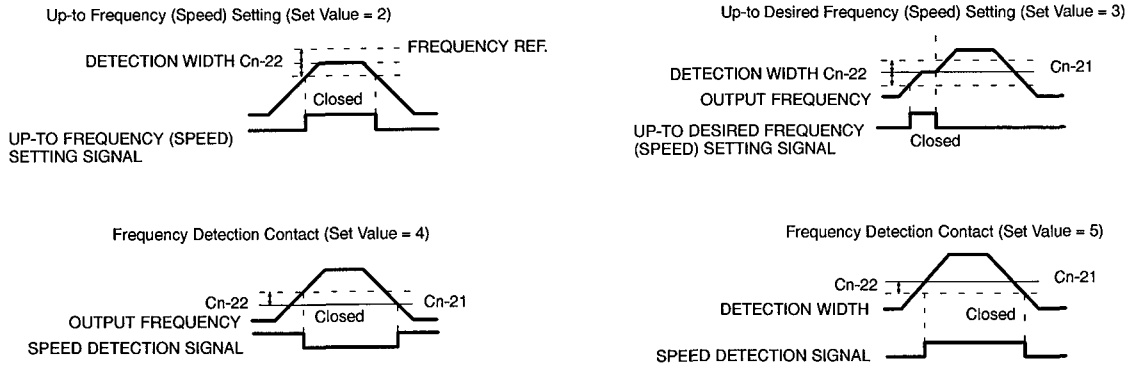

### 4-3 GPD 503 Operation Reference and External Inputs Relationship

This section will explain the order of priority when a GPD 503 AC Drive operation reference is executed by the Digital Monitor or by external input terminals other than communications, and will also describe how to change set values.

#### Operation Reference Priorities

The GPD 503 AC Drive is factory set for priority to be given to communication from the PLC regarding operation references, as opposed to operation references by either the Digital Monitor or external inputs. You can change the priority to either the Digital Monitor or external inputs by setting the second digits in Sn-08 and Sn-04.

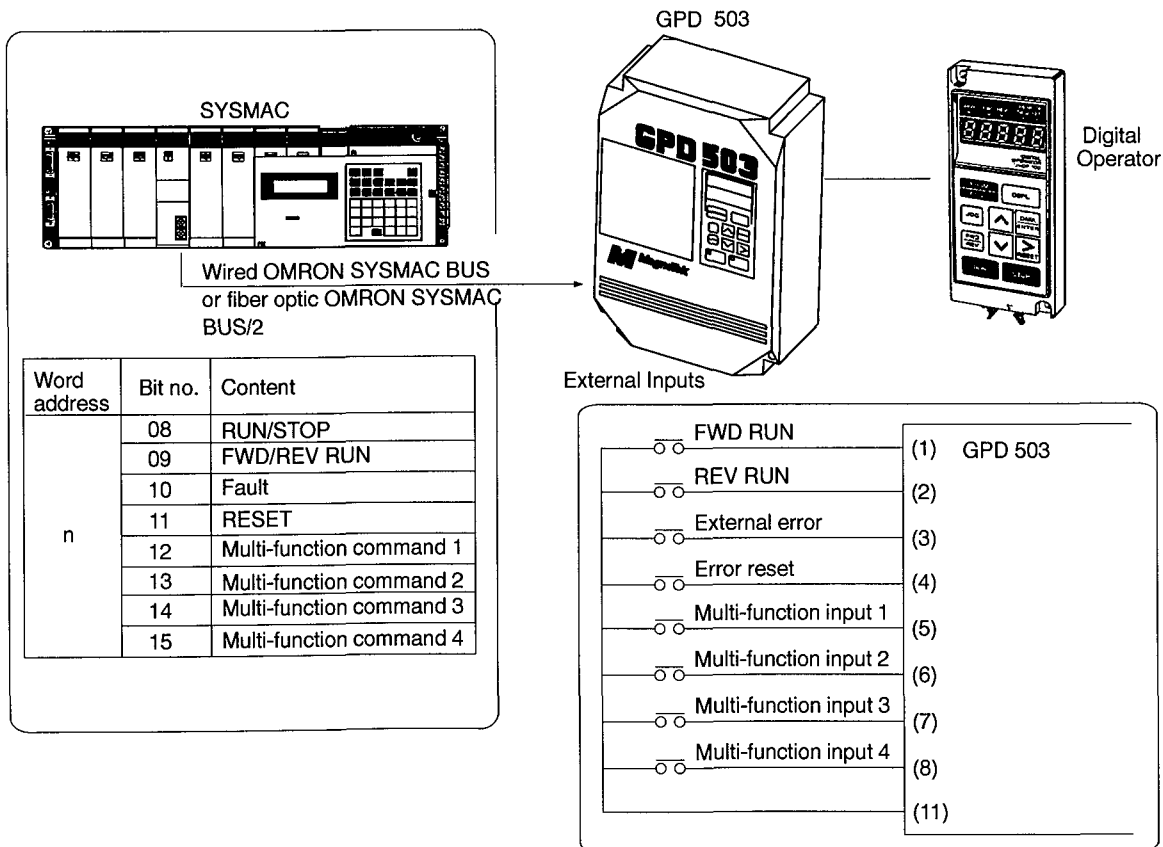

- Select source of drive operation command (START/STOP, FWD/REV, etc.)

Sn-04 2nd digit=0: Drive operation command input from the external terminals.  
 Sn-04 2nd digit=1: Drive operation command input from the Digital Operator.  
 Sn-08 2nd digit=0: Drive operation command received from the PLC. Digital Operator REMOTE SEQ LED lights. Sn-04 2nd digit setting does not matter.  
 Sn-08 2nd digit=1: Drive operation command from the drive, according to Sn-04 2nd digit.

Relation Between Operation References/External Inputs and System Constants

Operation reference		System constant setting				
		Sn-08 --0- (Factory setting)	Sn-08 --1-			
			Sn-04 --0-	Sn-04 --1-		
Operation references from PLC communications (word n+2, bits 08 to 15)	D8	RUN/STOP	Enabled**	Disabled	Disabled	
	D9	FWD/REV RUN	Enabled**	Disabled	Disabled	
	D10	Fault*	Enabled**	Disabled	Disabled	
	D11	RESET*	Enabled	Enabled	Enabled	
	D12	Multi-function command 1*	Enabled	Enabled	Enabled	
	D13	Multi-function command 2*	Enabled	Enabled	Enabled	
	D14	Multi-function command 3*	Enabled	Enabled	Enabled	
	D15	Multi-function command 4*	Enabled	Enabled	Enabled	
Operation references from Inverter	External terminal inputs	(1)	FWD/STOP	Disabled	Enabled**	Disabled
		(2)	REV/STOP	Disabled	Enabled**	Disabled
		(3)	External error*	Enabled	Enabled	Enabled
		(4)	Error reset*	Enabled	Enabled	Enabled
		(5)	Multi-function input 1*	Enabled	Enabled	Enabled
		(6)	Multi-function input 2*	Enabled	Enabled	Enabled
		(7)	Multi-function input 3*	Enabled	Enabled	Enabled
		(8)	Multi-function input 4*	Enabled	Enabled	Enabled
	Digital Operator	RUN		Disabled	Disabled	Enabled**
		STOP		Enabled	Enabled	Enabled
		RESET		Enabled	Enabled	Enabled

- Note**
- \*For fault, RESET, and the four multi-function command inputs, there is a logical OR relationship between commands from PLC communications and external terminals.
  - \*\*Can be toggled between enabled and disabled by changes in Sn-08 and Sn-04.

## 4-4 Master Frequency References and External Inputs Relationship

This section will describe operation at frequencies set by external analog inputs or multi-step speeds (9 steps).

**Changing Master Frequency Reference Reception**

The GPD 503 AC Drive is factory set to receive master frequency references via communications (data codes E5, E6) from the PLC. If you wish, you can change the setting to either Digital Operator or external inputs by setting the first digits in Sn-08 and Sn-04.

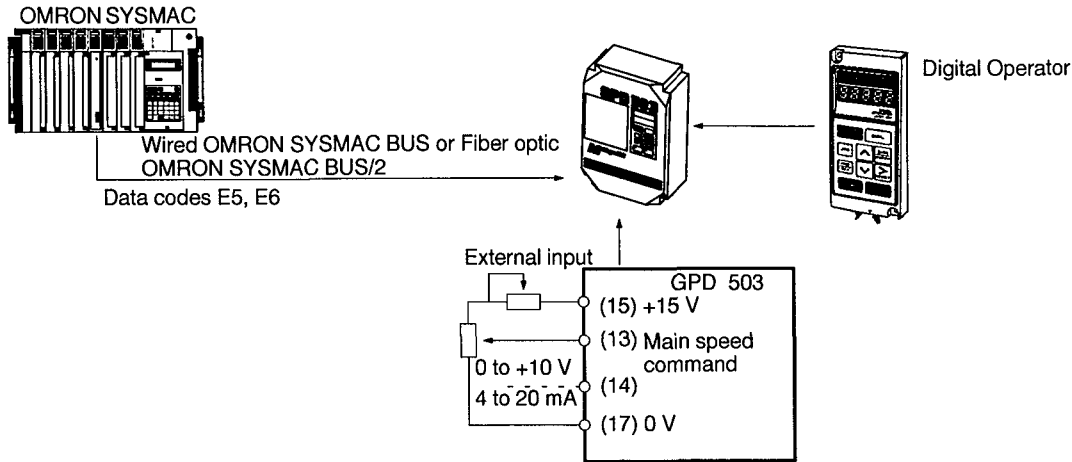

**• Select frequency reference source**

- Sn-04 1st digit=0: Drive frequency reference is analog input from external terminal 13 (0-10 Vdc) or 14 (4-20mA).
- Sn-04 1st digit=1: Drive frequency reference input from the Digital Operator.
- Sn-08 1st digit=0: Drive frequency reference received from the PLC. Digital Operator REMOTE REF LED lights. Sn-04 1st digit setting does not matter.
- Sn-08 1st digit=1: Drive frequency reference from the GPD 503, according to Sn-04 1st digit. Sn-04 setting determines if the reference comes from the Digital Operator or analog reference.

**Relation Between Frequency References/External Inputs and System Constants**

Constant setting		Master frequency references
Sn-08 —0- (Factory setting)		Frequency references from PLC communications (data code E5, E6)
Sn-08 —1	Sn-04 —0	Frequency references from analog inputs (terminals 13, 14)
	Sn-04 —1	Frequency references from Digital Operator

### 4-4-1 Multi-step Speed Operation

By means of frequency references from the PLC, any frequency can be set during GPD 503 AC Drive operation. In addition, multi-step speed operation with up to nine steps is possible through the multi-step speed commands and jog frequency reference selections in multi-function commands (inputs) 1 to 4.

Relation Between Frequency Reference Inputs and Set Output Frequencies

Set output frequency	Multi-step speed command 1 (5)	Multi-step speed command 2 (6)	Multi-step speed command 3 (7)	Jog frequency reference select (8)
Master frequency reference Frequency reference data codes E5 and E6, by PLC communication (see note 1)	OFF	OFF	OFF	OFF
Aux. frequency reference (An-02) (see note 2)	ON	OFF	OFF	OFF
Frequency reference 3 (An-03)	OFF	ON	OFF	OFF
Frequency reference 4 (An-04)	ON	ON	OFF	OFF
Frequency reference 5 (An-05)	OFF	OFF	ON	OFF
Frequency reference 6 (An-06)	ON	OFF	ON	OFF
Frequency reference 7 (An-07)	OFF	ON	ON	OFF
Frequency reference 8 (An-08)	ON	ON	ON	OFF
Jog frequency reference (An-09)	ON or OFF	ON or OFF	ON or OFF	ON

Multi-step speed commands 1 to 3 and jog frequency reference can be selected with Multi-function command inputs. Commands not selected will be treated as being OFF.

- Note**
1. By setting the first digits of Sn-08 and Sn-04, you can select whether master frequency references will come from PLC communications, the Digital Operation keyboard, or external command inputs.
  2. The auxiliary frequency reference is factory set to frequency reference 2. By setting Sn-19, it can be changed as shown below.

System constant	Auxiliary frequency reference
Sn-19 = 0000	Multi-function analog input terminals 16: Frequency can be changed by external volume.
Sn-19 = 0001 to 000F (Factory set to 000F.)	Frequency reference 2: Frequency can be changed by Digital Operator.

An-01 to An-09 frequency setting data can also be set by communications from the PLC.

# SECTION 5

## Communicating with PLCs

This section describes how the GPD 503 unit communicates with PLC's, programming to read and write data and what precautions to take when performing these operations.

5-1	Writing Data .....	42
5-1-1	Converting Write Data to Hexadecimal .....	42
5-1-2	Write Procedure .....	42
5-1-3	Processing when ENTER Command is Received .....	43
5-1-4	ENTER Command Not Received Error .....	44
5-1-5	Memory Data Backup .....	44
5-1-6	Data Write Program .....	45
5-2	Data Reading (Monitoring) .....	47
5-3	Precautions when Writing or Reading Data .....	48
5-3-1	Data Writing and Reading Conditions .....	48
5-3-2	Transmitting INITIALIZE DATA .....	48
5-4	Transmission Delay Time .....	49
5-4-1	Configuration Example .....	49
5-4-2	GPD 503 Internal Processing Time .....	49
5-4-3	Response Time for Wired OMRON SYSMAC BUS System .....	50
5-4-4	Response Time for fiber optic OMRON SYSMAC BUS/2 System .....	50



## 5-1 Writing Data

This section describes how to transmit data from the PLC to the GPD 503 AC Drive and how to set system constants (Sn-\_\_), control constants (Cn-\_\_), frequency reference constants (An-\_\_), constant to change during operation (bn-\_\_), and the frequency references, write data codes E5 and E6.

### Transmitting Data

	D15	D8 D7	D0	
n	Drive operation reference	Data code (write)		- - - Data code corresponding to data is set.
n+1	Write data			- - - Write data is set with hexadecimal.

### 5-1-1 Converting Write Data to Hexadecimal

#### Sn-\_\_ Set Values and Write Data Relation

System constant (Sn-\_\_) functions can be selected by setting the bits in the four digits to ON and OFF. The data is converted to hexadecimal as shown in the following table.

Set value				Write data setting
4th digit	3rd digit	2nd digit	1st digit	
0	0	0	0	0000
0	0	0	1	0001
0	0	1	0	0002
0	0	1	1	0003
0	1	0	0	0004
0	1	0	1	0005
0	1	1	0	0006
0	1	1	1	0007
1	0	0	0	0008
1	0	0	1	0009
1	0	1	0	000A
1	0	1	1	000B
1	1	0	0	000C
1	1	0	1	000D
1	1	1	0	000E
1	1	1	1	000F

**Note** Transmit Sn-02 and Sn-15 to Sn-22 set values as write data just as they are.

#### Write Data and Cn, An, bn, and Frequency Reference Set Values Relation

Set values for control constants (Cn-\_\_), frequency reference constants (An-\_\_), constant to change during operation (bn-\_\_), and frequency references are expressed in setting units, and those values are converted to hexadecimal.

Example: 120.0 Hz (Setting Module: 0.1 Hz) Set for Cn-02 (Max. Frequency)

$$120.0 \text{ Hz} = \boxed{1200} \times 0.1 \text{ Hz (Setting unit)}$$

↓  
Converted to hexadecimal.

→  $\boxed{04B0}$  - - - Set as write data.

### 5-1-2 Write Procedure

GPD 503 AC Drive data is set simply by setting the data codes (write) allocated for each data item, and the write data, in words n (bits 00 to 07) and n+1 in the PLC. In order to establish the timing (handshake) with the PLC for transmitting data to the GPD 503 AC Drive, use the following procedure for writing.

**Data Code (Write) and Write Data Transmission**

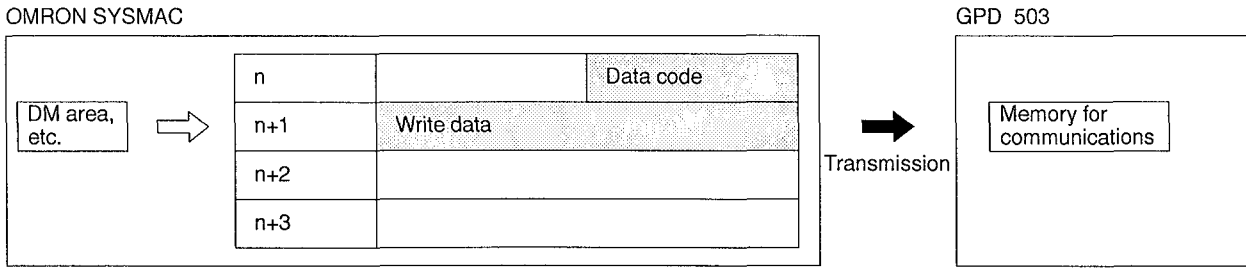

When data codes (write) and write data are transferred, by MOV(21) or other means, to words n (bits 00 to 07) and n+1 respectively, the data will then be sent to the GPD 503 AC Drive.

**Response from GPD 503**

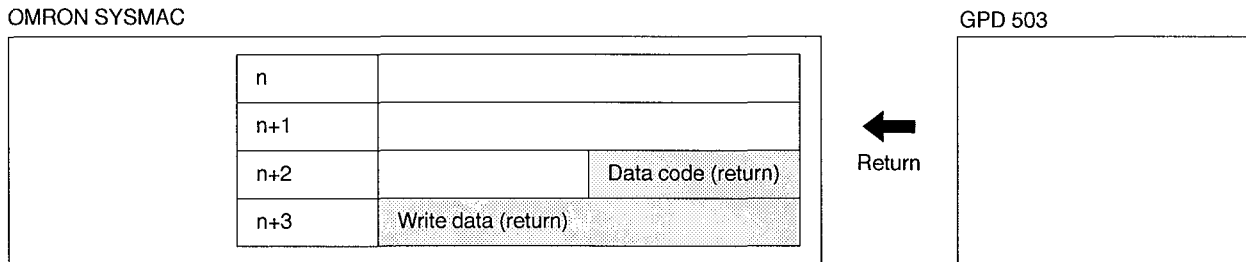

When the GPD 503 AC Drive receives the data, it will return the data code (return) and write data (return) that it received to words n+2 (bits 00 to 07) and n+3 respectively.

**Confirmation of Transmission Completion**

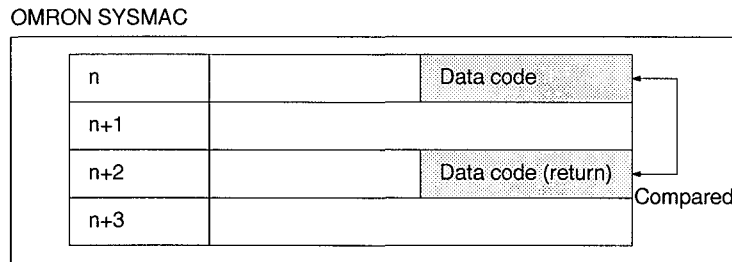

The PLC compares the data code that was sent, word n, bits 00 to 07, with the data code that was received, word n+2, bits 00 to 07, and checks whether or not they are identical. If they match, it determines that transmission processing is complete. In order to make the comparison, a program using instructions such as CMP(20) is required.

**Transmission of ENTER Command**

If the transmission is complete, then the next data can be transmitted. When transmission of all the necessary data has been completed, then the ENTER command, data code FD, write data 0000, will be transmitted. When the GPD 503 AC Drive receives the ENTER command, it takes in as data for operations that data which was previously sent by the PLC.

**5-1-3 Processing when ENTER Command is Received**

When the GPD 503 AC Drive receives the ENTER command, it transfers Sn-\_\_\_, Cn-\_\_\_, An-\_\_\_, and bn-\_\_\_ write data from its communications memory to its operations memory.

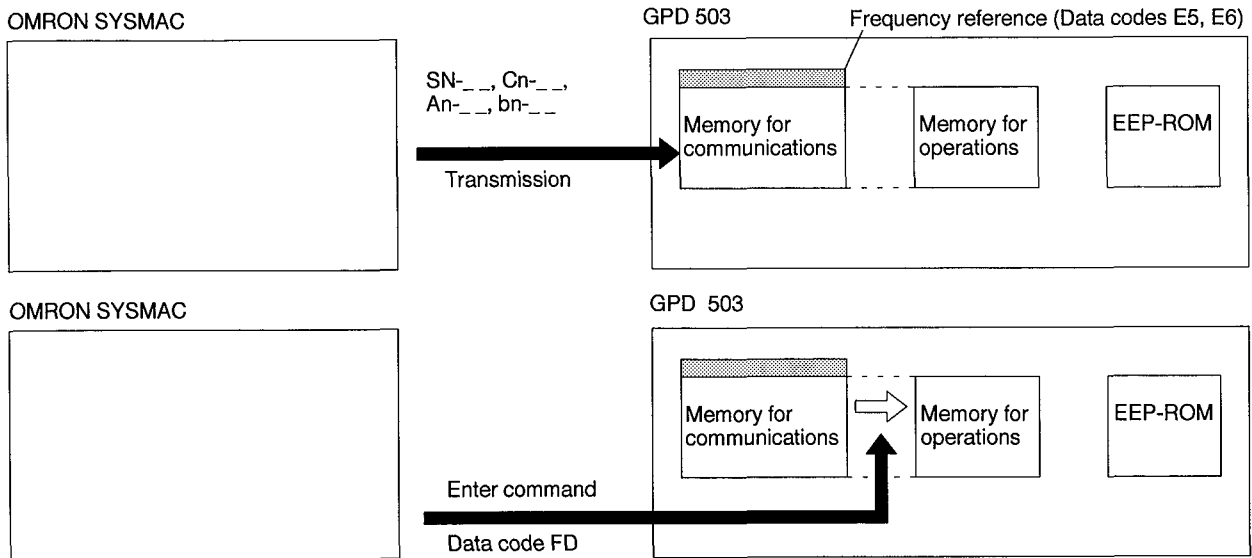

The ENTER command is not required for frequency references, data codes E5 and E6, set by PLC communications. It is necessary, however, for An-01 to An-09 frequency references.

### 5-1-4 ENTER Command Not Received Error

If the ENTER command is not received within five seconds after Sn-\_\_\_, Cn-\_\_\_, An-\_\_\_, or bn-\_\_\_ is written, an “ENTER command not received error” will be generated. At that time, the data setting error flag, word n+2, bit 12, will turn ON to advise that the ENTER command has not been input. If the ENTER command is received after that, the flag will turn OFF. Verification that an error has occurred is made by setting read data code 69 in word n, bits 00 to 07, and reading the data link status monitor into word n+3, and monitoring the ON status of the 6th bit, ENTER command not received error.

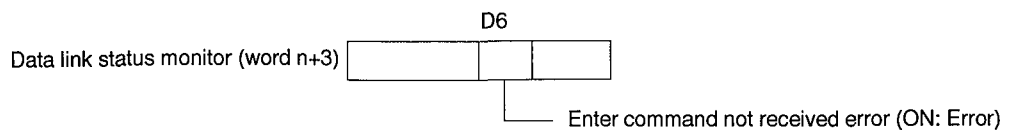
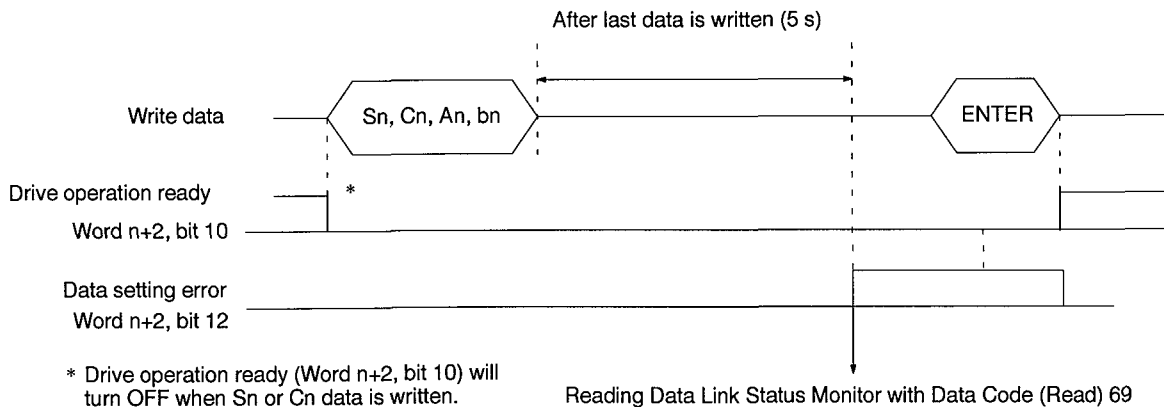

### 5-1-5 Memory Data Backup

GPD 503 AC Drive data is backed up by EEPROM in NV-RAM. Data is written from the operations memory to EEPROM whenever data is modified or power is turned off to the GPD 503 AC Drive.

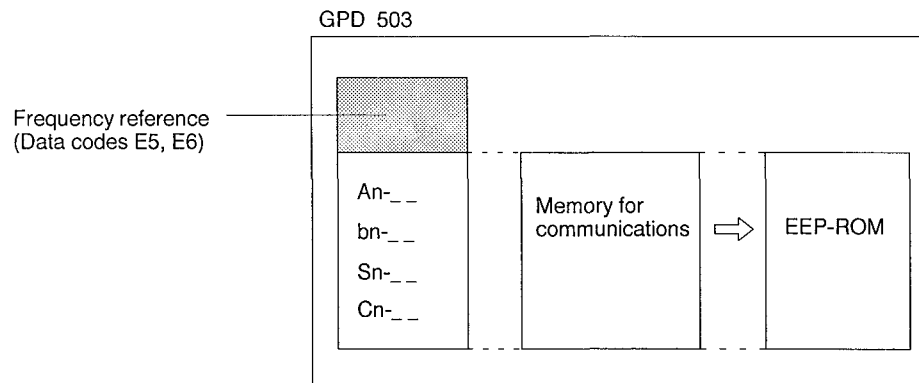

Data can be written to EEPROM a maximum of 100,000 times. Frequency references, data codes E5 and E6, cannot be saved to EPROM. The frequency will be 0 Hz when the power is turned on, so be sure to set these frequency references when powering up.

### 5-1-6 Data Write Program

The following example shows the basic procedure for writing data. When actually creating a program, refer to section 8 Program Examples.

#### Program Example

This is a program to change the frequency to 100.0 Hz during operation. When comparison output B turns ON, transmission is determined to be complete. (This program applies to C200H, C1000H, and C2000(H) Programmable Controllers.)

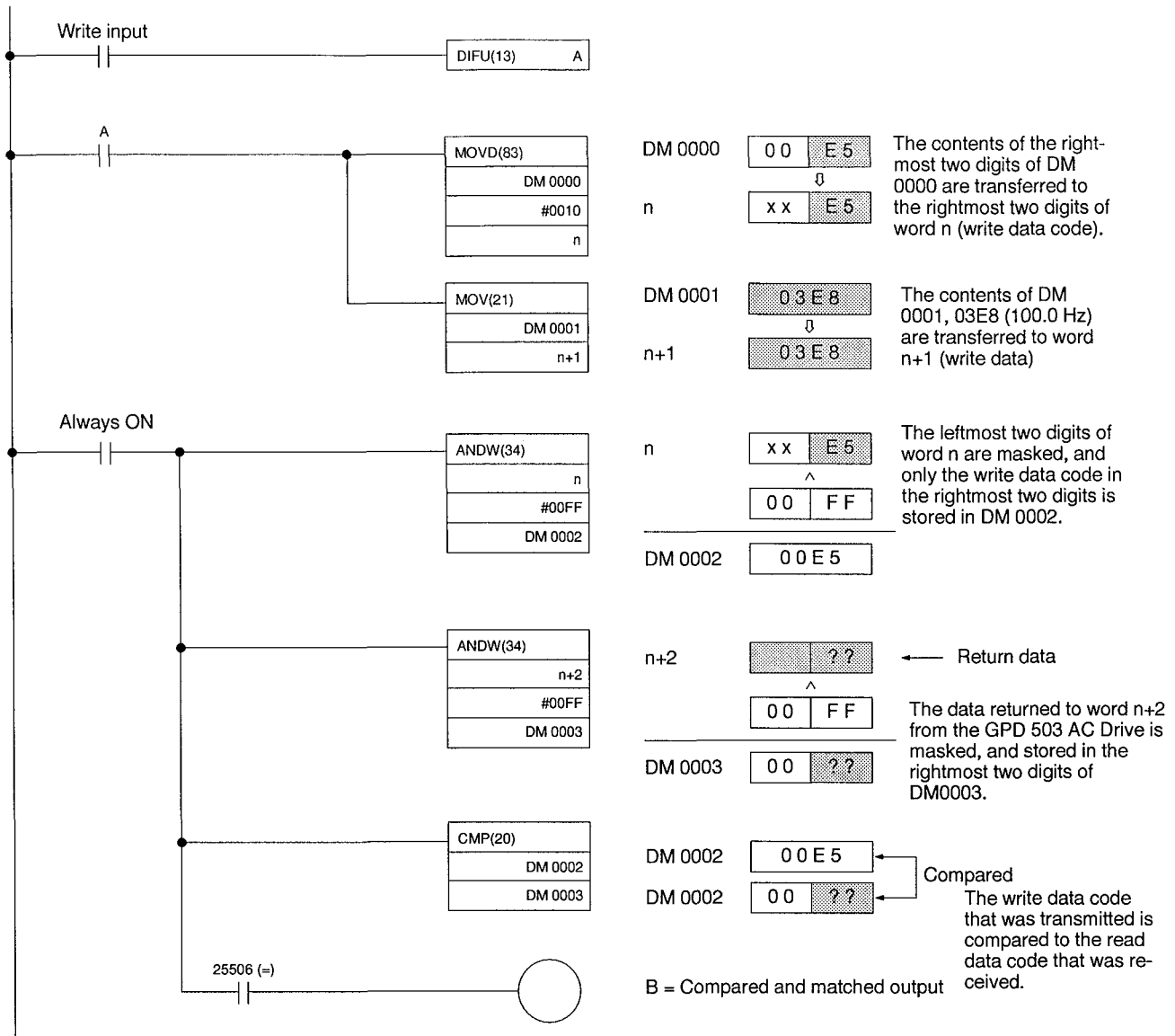

**Data Memory Contents**

DM 0000	00E5	Frequency reference write data code is set.
DM 0001	03E8	100.0 Hz (1000) is converted to hexadecimal and set.
DM 0002	00E5	Only the data code (write) to be transmitted (rightmost two digits) is stored.
DM 0003	00XX	The data code (write) return data (rightmost two digits) is stored.

**Transmitting the ENTER Command**

After the comparison output has been turned ON, the ENTER command data code FD must be transferred to word n, bits 07 to 00, and the ENTER command must be sent to the GPD 503 AC Drive.

## 5-2 Data Reading (Monitoring)

All GPD 503 AC Drive data, operating conditions, and error contents are read by the PLC.

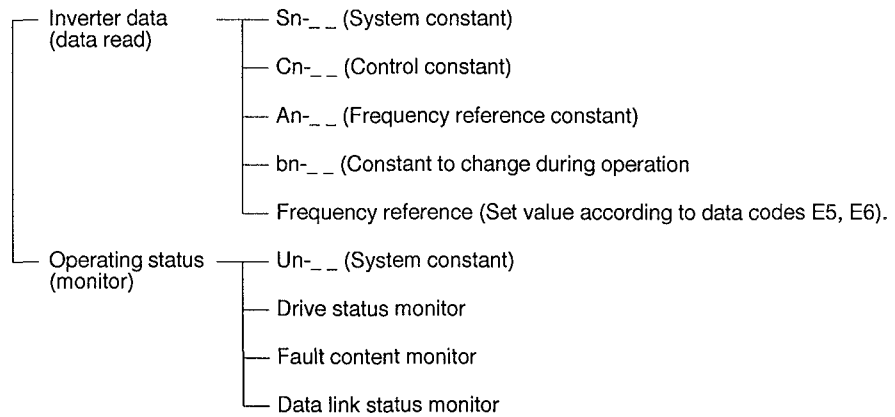

### Read (Monitor) Procedure

When the GPD 503 AC Drive receives from the PLC the data codes, read, allocated for all data, it will return the set values or monitor values to the PLC. The procedure for reading and monitoring this data is shown below.

#### Data Code Transmission

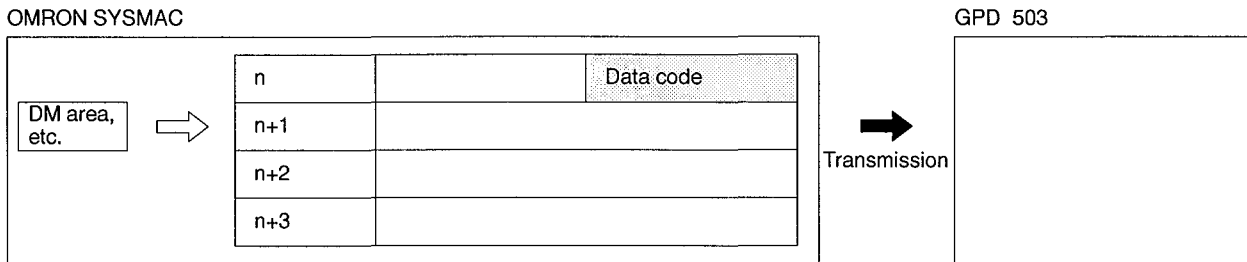

The data codes are transmitted to the GPD 503 AC Drive by transferring them to word n, bits 00 to 07, with MOV(21).

#### GPD 503 AC Drive Response

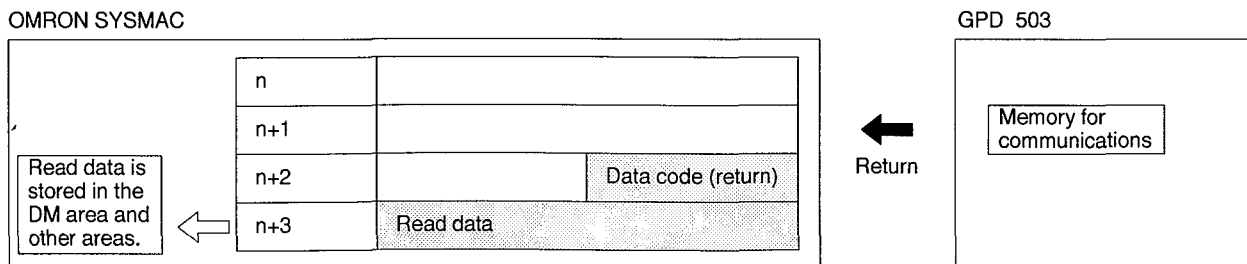

When the GPD 503 AC Drive receives the data codes, it transmits the corresponding set values and monitor values to word n+3 and the data codes to word n+2, bits 00 to 07.

PLC Reception Complete Confirmation

OMRON SYSMAC

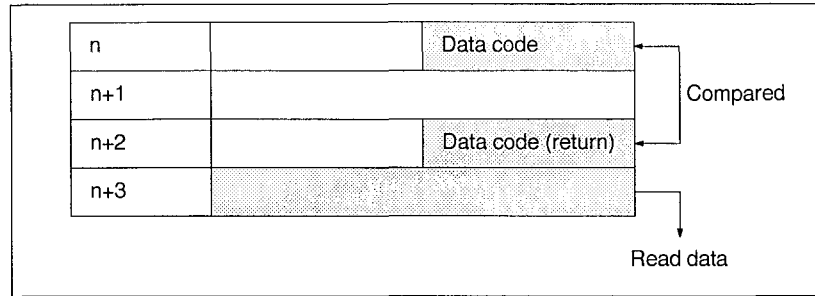

The PLC compares the data codes that were originally sent to word n, bits 00 to 07, with the data codes received back from the GPD 503 AC Drive and stored in word n+2, bits 00 to 07, and it determines whether or not the read operation is complete. If the result of the comparison shows that the data codes match, then the contents of word n+3 will be treated as read data.

In order to make the comparison, a program using instructions such as CMP(20) is required. If there is more data to be read, this process must be repeated from the beginning.

### 5-3 Precautions when Writing or Reading Data

#### 5-3-1 Data Writing and Reading Conditions

PLC writing and reading of data is restricted by GPD 503 AC Drive operating conditions. Frequency references and acceleration/deceleration times (bn-\_\_ ) can be changed even during operation.

	Data	Write	Read	ENTER
Set data	Sn-__: System constant	Possible only when GPD 503 AC Drive is stopped.	Possible during GPD 503 AC Drive operation.	Required for write. Not required for read.
	Cn-__: Control constant			
	An-__: Frequency reference constant	Possible during GPD 503 AC Drive operation.		
	bn-__: Constant to change during operation			
	Frequency reference (Enabled only during communications.)			Not required.
Status monitor	Un-__: Monitor display constant	—	Possible during GPD 503 AC Drive operation.	Not required.
	Inverter status			
	Error content monitor			
	Data link status			

#### 5-3-2 Transmitting INITIALIZE DATA

Follow the procedure shown below to first transmit INITIALIZE DATA (Sn-03 = 1110 or 1111), and then refresh the data after it has been initialized.

Refresh Procedure

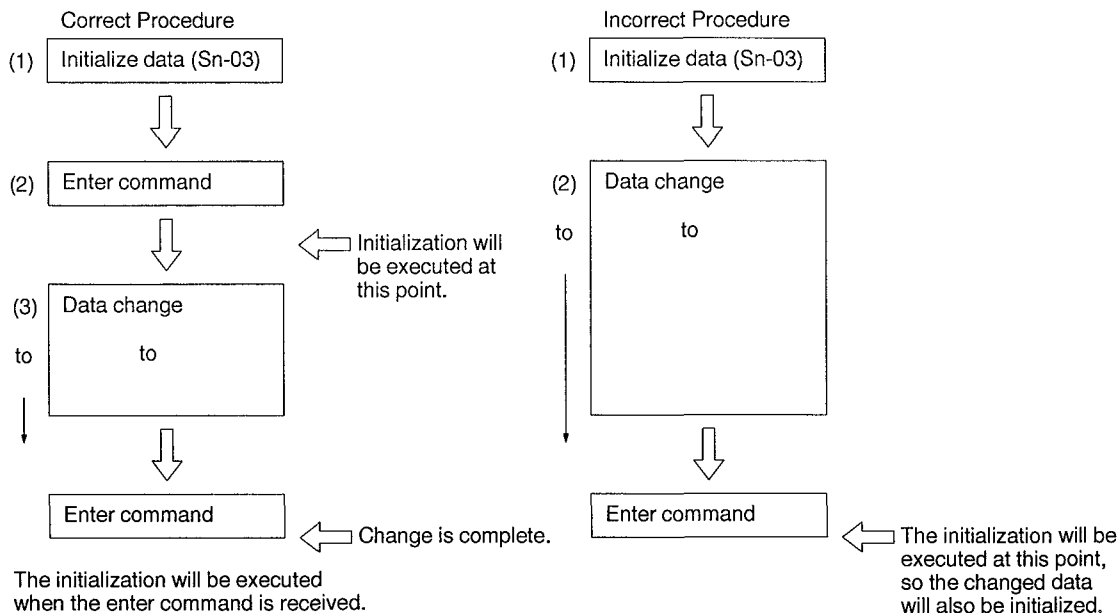

## 5-4 Transmission Delay Time

### 5-4-1 Configuration Example

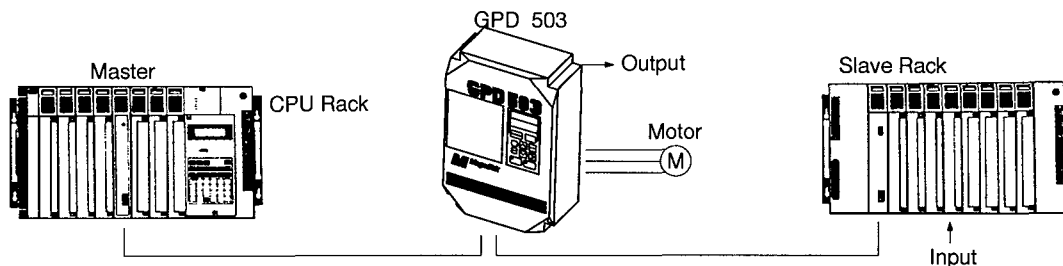

### Circuit Example

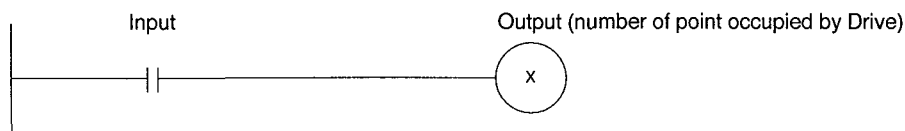

Transmission time to the Drive is the same for contact output by Drive commands or data code transfer by MOV(21). The calculation of the response time from the time the input turns ON at the Slave to the time the Drive output changes is shown below.

### 5-4-2 Inverter Internal Processing Time

The time required for the to process data after it has been sent via OMRON SYSMAC BUS or OMRON SYSMAC BUS/2 is as follows:

- Minimum response time: 5 ms
- Maximum response time: 25 ms

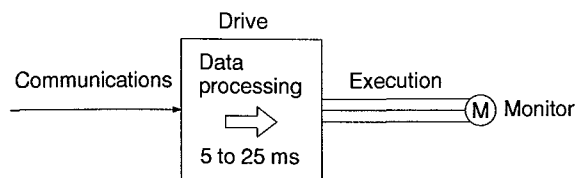



## 5-4-3 Response Time for Wired OMRON SYSMAC BUS System

CPU Rack	Minimum response time	Maximum response time
C1000H/C2000H/ C2000	Input ON response time + (cycle time x 2) + $T_{RM}$ + Drive output minimum response time (5 ms)	Input ON response time + (cycle time x 3) + ( $T_{RM} \times 2$ ) + (1/2 $T_{RT}$ + 1/2 $T_{TT}$ ) + Drive output maximum response time (25 ms)
C500/C120	Input ON response time + cycle time + $T_{RM}$ + Drive output minimum response time (5 ms)	Input ON response time + (cycle time x 2) + ( $T_{RM} \times 2$ ) + (1/2 $T_{RT}$ + 1/2 $T_{TT}$ ) + Drive output maximum response time (25 ms)
C200H	Input ON response time + (cycle time x 3) + Drive output minimum response time (5 ms) (Given that the remote transmission time is less than the scan time.)	Input ON response time + (cycle time x 4) + Drive output maximum response time (25 ms) (Given that the remote transmission time is less than the scan time.)
CV500/CV1000 (Asynchronous processing)	Input ON response time + 5N + $T_{RM}$ + Drive output minimum response time (5 ms) (N: Number of Masters on OMRON SYSMAC BUS)	Input ON response time + (cycle time + 5N) + ( $T_{RM} \times 2$ ) + (1/2 $T_{RT}$ + 1/2 $T_{TT}$ ) + Drive output maximum response time (25 ms) (N: Number of Masters on OMRON SYSMAC BUS)
CV500/CV1000 (Synchronous processing)	Input ON response time + cycle time + $T_{RT}$ + $T_{TT}$ + Drive output minimum response time (5 ms)	Input ON response time + (cycle time x 2) + ( $T_{RM} \times 2$ ) + $T_{RT}$ + $T_{TT}$ + Drive output maximum response time (25 ms)

$T_{RM}$  = Total Slave transmission time per Master (communications cycle time) =  $\Sigma T_{RT} + T_{TT}$   
 $T_{RT}$  = Transmission time per Slave (RI) = 1.4 ms + (0.2 ms x n)  
 $T_{TT}$  = Transmission time per Drive = 4 ms  
(m: Total number of words for transmission I/O)  
(n: Total number of words for relevant Slave I/O)

## 5-4-4 Response Time for fiber optic OMRON SYSMAC BUS/2 System

CPU Rack	Minimum response time	Maximum response time
CV500/CV1000 (Asynchronous processing)	Input ON response time + ( $T_{RM} \times 6$ ) + Remote refresh time + Drive output minimum response time (5 ms)	Input ON response time + ( $T_{RM} \times 8$ ) + Cycle time + Remote refresh time + 15 ms + Drive output maximum response time (25 ms)
CV500/CV1000 (Synchronous processing)	Input ON response time + ( $T_{RM} \times 5$ ) + (cycle time x 2) + Drive output minimum response time (5 ms)	Input ON response time + ( $T_{RM} \times 7$ ) + (cycle time x 3) + 10 ms + Drive output maximum response time (25 ms)

Remote refresh time = 2.0 ms + (number of words refreshed x 0.001 ms)  
 $T_{RM}$  = Total Slave transmission time per Master (communications cycle time)

## Transmission Time per Slave

		Fiber-optic
Group 1 Slave (Drives, etc.)		0.32 ms/Slave
Group 2 Slave		0.47 ms/Slave
Group 3 Slave	58 M	1.89 ms/Slave
	54 MH	4.5 ms/Slave
	122 M	4.5 ms/Slave

**Note** If the total communications time is 5 ms or less, it will be considered as 5 ms.

The communications cycle time may also be set by OMRON SYSMAC BUS/2 system settings. For details, refer to your *OMRON SYSMAC BUS/2 System Manual*, as listed on page 2.

# SECTION 6

## Error Processing

This section describes the GPD 503 AC Drive's error processing features and how it operates when an error occurs.

6-1	Data Setting Errors .....	54
6-2	GPD 503 AC Drive's Operations When Transmission Error Occurs .....	55

# 6-1 Data Setting Errors

If a data setting error should occur when writing or reading data from the PLC to the GPD 503 AC Drive, the Drive Status Data Setting Error Flag, n+2, bit 12 will turn ON. For write mode errors, data code errors, or setting range error-A (up/down limit errors), error code FF will be returned to word n+2, bits 00 to 07, and the data link status will be returned to word n+3.

## When a Data Setting Error Occurs

Word address	Bit no.															
	15	14	13	12	11	10	09	08	07	06	05	04	03	02	01	00
n																
n+1																
n+2				1					F				F			
n+3	Data link status (data setting error contents)															

## GPD 503 AC Drive Set Data Check Processing

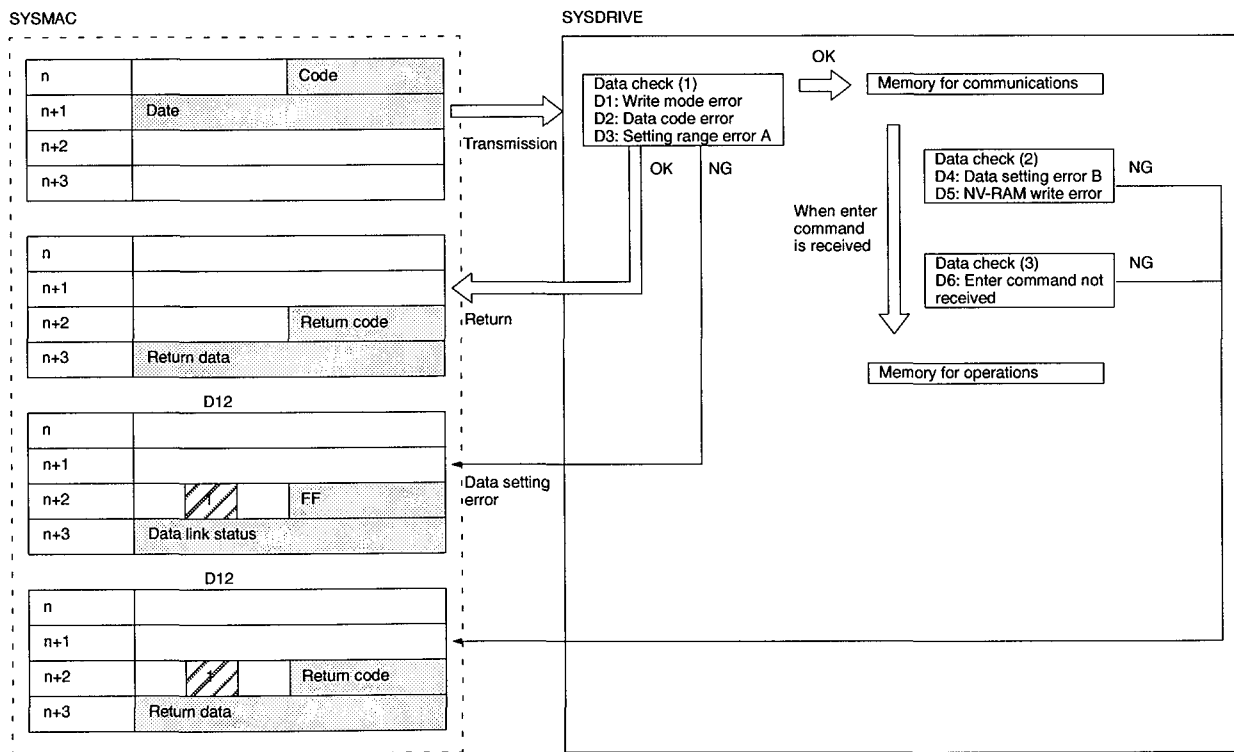

## Data Setting Errors

n			8*	4*	--- : Sn-04 data code
n+1	0	1	0	5	--- : Abnormal data setting (Sn-04 setting range 0000 to 00FF)
n+2			F*	F*	
n+3	0	0	0	8	--- : Data link status: abnormal Sn-04 setting limits

\*The data in word n (bits 00 to 07) and n+2 bits 00 to 07, does not match, so processing cannot proceed to the next data.

If error bits D1 to D6 for the data link status, n+3, turn ON, the Data Setting Error Flag, n+2, bit 12, will turn ON.

Data Code		Data		
Read (HEX)	Write (HEX)	Data name	Data range	Data range (HEX conversion)
69	—	Data link status	16-bit data	0000 to _ _ _ _

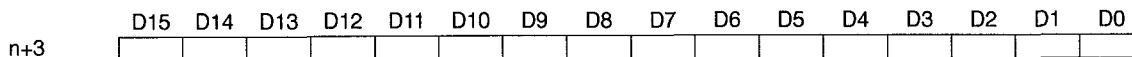

Bit no.	Item	Error content
D0	During data write processing	Data being received.
D1	Write mode error	Sn or Cn write data code was received during Drive operation.
D2	Data code error	An unregistered data code was received.
D3	Setting range error A (Up/down limit error)	Write data was received outside of the setting range.
D4	Setting range error B (Adjustment error)	Write data was received without adjustment (V/f setting, etc.)
D5	NV-RAM write error	NV-RAM writing defect (BCC error)
D6	ENTER command not received	ENTER command was not received after change in constant settings.

## 6-2 GPD 503 AC Drive Operations When Transmission Error Occurs

If OMRON SYSMAC BUS or OMRON SYSMAC BUS/2 communications are stopped during operation due to a break in the transmission path or a transmission error, the GPD 503 AC Drive will coast to a stop, as factory set. If you wish to change the factory setting, you can set the third and fourth digits of Sn-08 to select another error processing method.

Data Code			Data			
Read (HEX)	Write (HEX)	Data no.	Data name	Digit	Set data	Operation
08	88	Sn-08	RUN Mode Select 5 (Transmission error processing)	3 digits	Processing when transmission error is detected: 00: Deceleration stop (Deceleration time 1: bn-02) 01: Coasting stop (Factory setting) 10: Deceleration stop (Deceleration time 2: bn-04) 11: Continuous operation	
				4 digits		

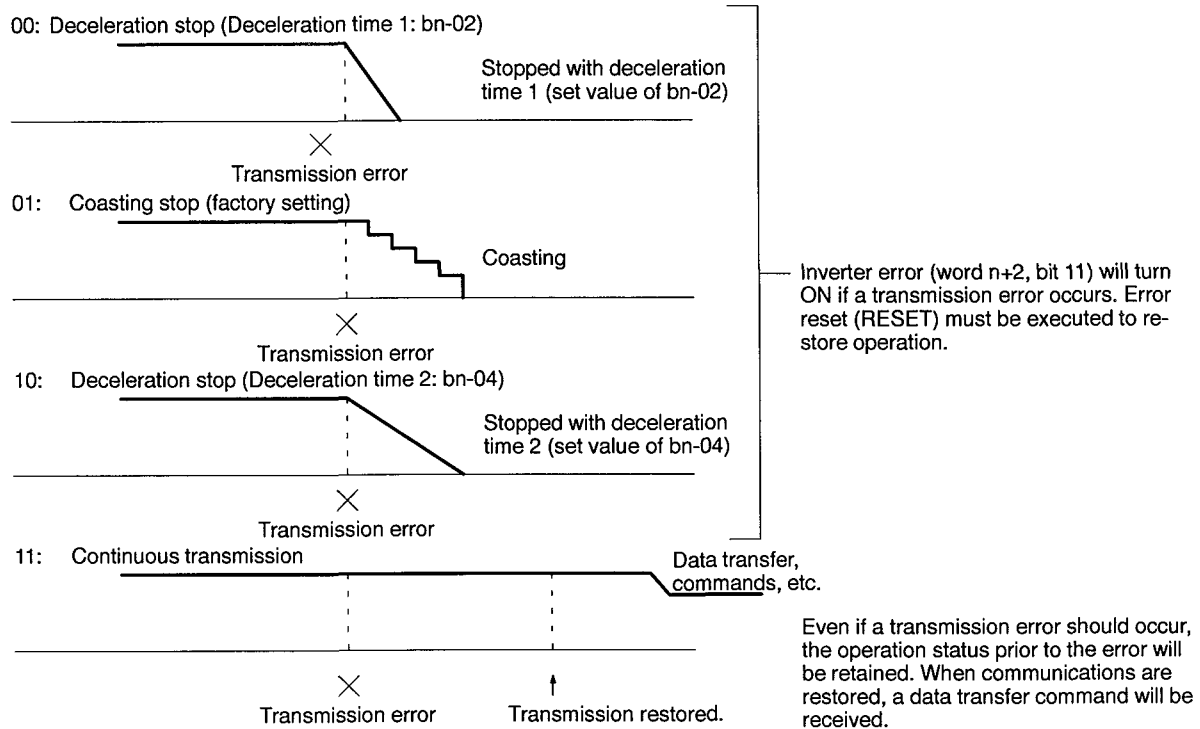
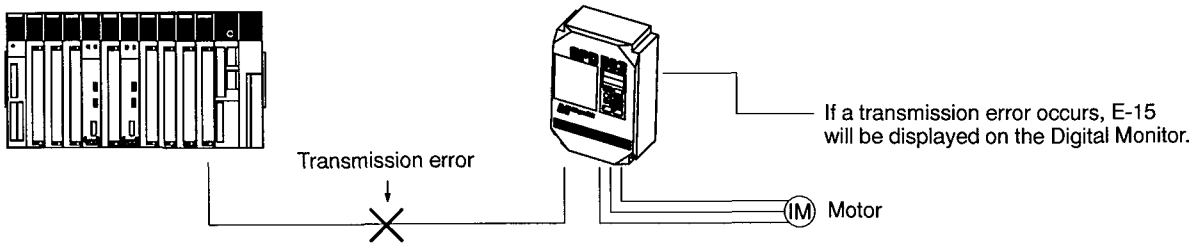

# SECTION 7

## Data Code Charts

This section provides the user with the data codes required in operating the GPD 503 AC Drive.

7-1	Converting Set Values to Hexidecimals .....	56
7-2	System Constant Sn-__ .....	57
7-3	Control Constant Cn-__ .....	62
7-4	Frequency References An-__ .....	65
7-5	Changing Constants during Operation bn-__ .....	66
7-6	ENTER Command .....	66
7-7	Frequency References .....	67
7-8	Monitor Display Un-__ .....	68
7-8-1	Monitor Data .....	68
7-8-2	Drive Status .....	68
7-9	Fault Content Monitoring .....	69
7-10	Monitoring Data Link Status .....	70

## 7-1 Converting Set Values to Hexidecimals

The set value data is converted to hexadecimal as shown in the following table. Use this table to convert the set values indicated in the following sections.

Set value				Write data setting
4th bit	3rd bit	2nd bit	1st bit	
0	0	0	0	0000
0	0	0	1	0001
0	0	1	0	0002
0	0	1	1	0003
0	1	0	0	0004
0	1	0	1	0005
0	1	1	0	0006
0	1	1	1	0007
1	0	0	0	0008
1	0	0	1	0009
1	0	1	0	000A
1	0	1	1	000B
1	1	0	0	000C
1	1	0	1	000D
1	1	1	0	000E
1	1	1	1	000F

**Note** Transmit Sn-02 and Sn-15 to Sn-22 set values as write data just as they are.

## 7-2 System Constant Sn-\_\_

Data Code			Data					Set value	Set value (HEX)
Read (HEX)	Write (HEX)	Data no.	Data name	Bit no.	Setting Data	Function	Initial setting (HEX)		
—	—	Sn-01	Drive capacity	—		Drive capacity selected			
02	82	Sn-02	V/f pattern	—		V/f pattern selected	000F*		
03	83	Sn-03	Operator Status	Write Prohibit Setting		0000: Setting and reading of An-__, bn-__, Sn-__, Cn-__ enabled. 0101: Setting and reading of An-__; reading of bn-__, Sn-__, Cn-__ enabled.	0000 (0000)		
				Constants Initialization		1110: NVRAM initialization (Equivalent to 2-wire sequence.) 1111: NVRAM initialization (Equivalent to 3-wire sequence.)			
04	84	Sn-04	Operation Mode Select 1	Operation Method Select	1st bit	0	Master frequency reference by analog input of external terminals (13), (14).	0011 (0003)	
						1	Master frequency reference by frequency reference 1 (An-01).		
					2nd bit	0	External terminal operation reference effective.		
						1	Keypad operation reference effective.		
Stopping Method Select	3rd bit	00: Deceleration stop 01: Coasting to stop 10: Full-range DC stop							
	4th bit	11: Coasting stop (Can be restarted after time set by bn-02.)							

MagneTek recommends setting this value = 0000 during initial start up.



Data Code			Data					Set value	Set value (HEX)
Read (HEX)	Write (HEX)	Data no.	Data name	Bit no.	Setting Data	Function	Initial setting (HEX)		
05	85	Sn-05	Operation Mode Select 2	1st bit	0	Keypad STOP Key enabled during operation from external terminals (communications function).	0000 (0000)		
					1	Keypad STOP Key disabled during operation from external terminals (communications function).			
				2nd bit	0	Reverse operation possible.			
					1	Reverse operation not possible.			
				3rd bit	0	Not used			
					1	Not used			
				4th bit	0	Analog monitor output (terminals 21 and 22) is output frequency.			
					1	Analog monitor output (terminals 21 and 22) is output current.			
06	86	Sn-06	Operation Mode Select 3	1st bit	00: S-curve: 0.2 s		0000 (0000)		
					01: No S-curve				
				2nd bit	10: S-curve: 0.5 s				
					11: S-curve: 1.0 s				
				3rd bit	0	Not used			
					1	Not used			
4th bit	0	Not used							
	1	Not used							
07	87	Sn-07	Operation Mode Select 4 (Over-torque Detection)	1st bit	0	Over-torque detection not enabled.	0000 (0000)		
					1	Over-torque detection enabled.			
				2nd bit	0	Enabled only if at set speed.			
					1	Enabled during operation (including acceleration).			
				3rd bit	0	Operation continued after over-torque is detected.			
					1	Coasts to stop if over-torque is detected.			
4th bit		—							

Data Code			Data					Set value	Set value (HEX)							
Read (HEX)	Write (HEX)	Data no.	Data name	Bit no.	Setting Data	Function	Initial setting (HEX)									
08	88	Sn-08	Operation Mode Select 5 (Command Select) (Transmission error processing)	1st bit	0	Operates by option card frequency references (when comm card is installed).	0100 (0004)									
					1	Operates by drive frequency references.										
				2nd bit	0	Operates by option card frequency references (when comm card is installed).										
					1	Operates by drive frequency references.										
				3rd bit	Operation when transmission error is detected (when comm card is installed): 00: Deceleration stop (Deceleration time 1: bn-02)											
				4th bit	01: Coast to stop 10: Deceleration stop (Deceleration time 2: bn-04) 11: Continuous operation											
				09	89	Sn-09				Not used			Not used	0000 (0000)		
				0A	8A	Sn-10				Protective Characteristics Select 1 (Stall Prevention)	1st bit	0	Stall prevention during acceleration enabled.	0000 (0000)		
1	Stall prevention during acceleration not enabled.															
2nd bit	0	Stall prevention during deceleration enabled.														
	1	Stall prevention during deceleration not enabled.														
3rd bit	0	Stall prevention during operation enabled.														
	1	Stall prevention during operation not enabled.														
4th bit	0	Not used														
	1	Not used														

Data Code			Data					Set value	Set value (HEX)
Read (HEX)	Write (HEX)	Data no.	Data name	Bit no.	Setting Data	Function	Initial setting (HEX)		
0B	8B	Sn-11	Protective Characteristics Select 2	1st bit	0	No built-in braking resistance (overheating protection not enabled).	0000 (0000)		
					1	Built-in braking resistance (overheating protection enabled).			
				2nd bit	0	Fault contact is not energized during auto reset/restart operation.			
					1	Fault contact is energized during auto reset/restart operation.			
				3rd bit	0	Operation stopped by momentary power loss detection.			
					1	Operation continues after momentary power loss detection.			
				4th bit		—			
0C	8C	Sn-12	Protective Characteristics Select 3 (External Fault Signal Input Terminal 3)	1st bit	0	External fault input: NO-contact input	0100 (0004)		
					1	External fault input: NC-contact input			
				2nd bit	0	External fault signal is always detected.			
					1	External fault signal is detected only during operation.			
				3rd bit	Operation when transmission error is detected: 00: Deceleration stop (Deceleration time 1: bn-02)				
				4th bit	01: Coast to stop 10: Deceleration stop (Deceleration time 2: bn-04) 11: Continuous operation				
0D	8D	Sn-13	Protective Characteristics Select 4	Not used			0000 (0000)		

Data Code			Data					Set value	Set value (HEX)
Read (HEX)	Write (HEX)	Data no.	Data name	Bit no.	Setting Data	Function	Initial setting (HEX)		
0E	8E	Sn-14	Protective Characteristics Select 5 (Motor Protection)	1st bit	0	Electronic thermal motor protection effective.	0000 (0000)		
					1	Electronic thermal motor protection not effective.			
				2nd bit	0	Electronic thermal characteristics are in accordance with variable torque operation.			
					1	Electronic thermal characteristics are in accordance with constant torque operation.			
				3rd, 4th bits	—				
0F	8F	Sn-15	Terminal 5 Function	—	00 to FF	Selects input terminal (5) function. (Factory set for multi-step speed reference 1.)	0003		
10	90	Sn-16	Terminal 6 Function	—	00 to FF	Selects input terminal (6) function. (Factory set for multi-step speed reference 2.)	0004		
11	91	Sn-17	Terminal 7 Function	—	00 to FF	Selects input terminal (7) function. (Factory set for jog frequency reference.)	0006		
12	92	Sn-18	Terminal 8 Function	—	00 to FF	Selects input terminal (8) function. (Factory set for external base-block.)	0008		
13	93	Sn-19	Auxiliary Analog Reference Input (AUX) Function	—	00 to 0F	Selects multi-function analog input (terminal 16) function.	000F		
14	94	Sn-20	Multi-function Output 1 Function	—	00 to F	Selects multi-function contact output (terminals 9 and 10) function.	0000		
15	95	Sn-21	Multi-function Output 2 Function	—	00 to F	Selects multi-function PHC (terminal 25) function.	0001		
16	96	Sn-22	Multi-function Output 3 Function	—	00 to F	Selects multi-function PHC (terminal 26) function.	0002		
—	—	Sn-23	—	—	—	—	—		
—	—	Sn-24	—	—	—	—	—		
—	—	Sn-27	Pulse Monitor Card* (P036F) (No. of pulse monitor output pulses)	1st bit	0000: 1 x output frequency (1F) 0010: 6 x output frequency (6F)	0010 (0002)			
				2nd bit	0100: 10 x output frequency (10F)				
				3rd bit	0110: 12 x output frequency (12F)				
				4th bit	1000: 36 x output frequency (36F)				

Data Code			Data					Set value	Set value (HEX)
Read (HEX)	Write (HEX)	Data no.	Data name	Bit no.	Setting Data	Function	Initial setting (HEX)		
—	—	Sn-28	Analog* Monitor Card (A08, PA012)	Wd 1	1st bit	00: Output frequency (max. frequency/100%) 01: Output current (rated current/100%) 10: Voltage reference (input voltage/100%) 11: DC voltage (400 V/100% for 200 V class)	0100 (0004)		
					2nd bit				
				Wd 2	3rd bit				
					4th bit				

These option cards can only be installed and used when the SCB-BUS/2 communication board is installed.

### 7-3 Control Constant Cn-\_\_

Data Code			Data						Set value	Set value (HEX)
Read (HEX)	Write (HEX)	Data no.	Data name	Setting unit	Setting range	Initial value	Setting range input data	Initial setting (HEX)		
1D	9D	Cn-01	Input voltage	0.1 V	0.0 to 255.0 (200 V) 0.0 to 510.0 (400 V)	200.0 (200 V) 400.0 (400 V) (see note 4)	0000 to 09F6 (200 V) 0000 to 13EC (400 V)	07D0 (200 V) 0FA0 (400 V)		
1E	9E	Cn-02	Max. frequency	0.1 Hz	50.0 to 400.0	(see note 2)	01F4 to 0FA0	(see note 2)		
1F	9F	Cn-03	Max. voltage	0.1 V	0.0 to 255.0 (200 V) 0.0 to 510.0 (400 V)	(see note 2)	0000 to 09F6 (200 V) 0000 to 13EC (400 V)	(see note 2)		
20	A0	Cn-04	Max. voltage frequency	0.1 Hz	0.0 to 400.0	(see note 2)	0000 to 0FA0	(see note 2)		
21	A1	Cn-05	Mid. output frequency	0.1 Hz	0.0 to 400.0	(see note 2)	0000 to 0FA0	(see note 2)		
22	A2	Cn-06	Mid. output frequency voltage	0.1 V	0.0 to 255.0 (200 V) 0.0 to 510.0 (400 V)	(see note 2)	0000 to 09F6 (200 V) 0000 to 13EC (400 V)	(see note 2)		
23	A3	Cn-07	Min. output frequency	0.1 Hz	0.0 to 400.0	(see note 2)	0000 to 0FA0	(see note 2)		
24	A4	Cn-08	Min. output frequency voltage	0.1 V	0.0 to 255.0 (200 V) 0.0 to 510.0 (400 V)	(see note 2)	0000 to 09F6 (200 V) 0000 to 13EC (400 V)	(see note 2)		
25	A5	Cn-09	Motor rated current	0.1 A	(see note 3)	(see note 1)	(see note 3)	(see note 1)		
26	A6	Cn-10	DC braking start frequency	0.1 Hz	0.0 to 10.0	(see note 2)	0000 to 0064	(see note 2)		
27	A7	Cn-11	DC braking current	1%	0 to 100	50	0000 to 0064	0032		
28	A8	Cn-12	DC braking time at stop	0.1 s	0.0 to 25.5	0.5	0000 to 00FF	0005		

Data Code			Data						Set value	Set value (HEX)
Read (HEX)	Write (HEX)	Data no.	Data name	Setting unit	Setting range	Initial value	Setting range input data	Initial setting (HEX)		
29	A9	Cn-13	DC braking time at start	0.1 s	0.0 to 25.5	0.0	0000 to 00FF	0000		
2A	AA	Cn-14	Frequency reference upper limit	1%	0 to 109	100	0000 to 006D	0064		
2B	AB	Cn-15	Frequency reference lower limit	1%	0 to 109	0	0000 to 006D	0000		
2C	AC	Cn-16	Setting prohibit frequency 1	0.1 Hz	0.0 to 400.0	0.0	0000 to 0FA0	0000		
2F	AF	Cn-19	Setting prohibit frequency range	0.1 Hz	0.0 to 25.5	1.0	0000 to 00FF	000A		
30	B0	Cn-20	Operator display mode	1	0 to 39999	0	0000 to 9C3F	0000		
31	B1	Cn-21	Up-to desired frequency level	0.1 Hz	0.0 to 400.0	0.0	0000 to 0FA0	0000		
32	B2	Cn-22	Up-to frequency setting detection width	0.1 Hz	0.0 to 25.5	2.0	0000 to 00FF	0014		
33	B3	Cn-23	Carrier frequency upper limit	0.1 kHz	0.4 to 15.0	15.0	0004 to 0096	0096		
34	B4	Cn-24	Carrier frequency lower limit	0.1 kHz	0.4 to 15.0	15.0	0004 to 0096	0096		
35	B5	Cn-25	Carrier frequency proportion gain	1	0 to 99	0	0000 to 0063	0000		
36	B6	Cn-26	Over-torque detection level	1%	30 to 200	160	001E to 00C8	00A0		
37	B7	Cn-27	Over-torque detection time	0.1 s	0.0 to 25.5	0.1	0000 to 00FF	0001		
38	B8	Cn-28	Stall prevention level during acceleration	1%	30 to 200	170	001E to 00C8	00AA		
39	B9	Cn-29	Stall prevention timing during acceleration	1%	30 to 200	50	001E to 00C8	0032		
3A	BA	Cn-30	Stall prevention level during deceleration	1%	30 to 200	160	001E to 00C8	00A0		
40	C0	Cn-36	Number of auto restart attempts	1	0 to 10	0	0000 to 000A	0000		
41	C1	Cn-37	Power loss ride-through deactivation time	0.1 s	0.0 to 2.0	(see note 1)	0000 to 0014	(see note 1)		

Data Code			Data						Set value	Set value (HEX)
Read (HEX)	Write (HEX)	Data no.	Data name	Setting unit	Setting range	Initial value	Setting range input data	Initial setting (HEX)		
42	C2	Cn-38	Speed search level	1%	0 to 200	150	0000 to 00C8	0096		
43	C3	Cn-39	Speed search time	0.1 s	0.0 to 25.5	2.0	0000 to 00FF	0014		

- Note**
1. The initial value will vary according to the Drive capacity, i.e., the set value of Sn-01.
  2. The initial value will vary according to the V/f, i.e., the set value of Sn-02.
  3. The setting range will be 30% to 200% of the Drive's rated current.
  4. Cn-01 must be set to 230.0 for a 230V input drive. Cn-01 must be set to 460.0 for a 460V input drive.

## 7-4 Frequency References An-\_\_

These references are used during multi-speed operation. An-\_\_ set values can be written during operation. The factory setting is for the master frequency setting to be made by frequency reference command, data codes E5 and E6.

Data Code			Data						Set value	Set value (HEX)
Read (HEX)	Write (HEX)	Data no.	Data name	Setting unit	Setting range	Initial value	Setting range input data	Initial setting (HEX)		
47	C7	An-01	Frequency reference 1	0.01 Hz	0.00 to 400.0	0.00	0000 to 9C40	0000		
48	C8	An-02	Frequency reference 2	0.01 Hz	0.00 to 400.0	0.00	0000 to 9C40	0000		
49	C9	An-03	Frequency reference 3	0.01 Hz	0.00 to 400.0	0.00	0000 to 9C40	0000		
4A	CA	An-04	Frequency reference 4	0.01 Hz	0.00 to 400.0	0.00	0000 to 9C40	0000		
4B	CB	An-05	Frequency reference 5	0.01 Hz	0.00 to 400.0	0.00	0000 to 9C40	0000		
4C	CC	An-06	Frequency reference 6	0.01 Hz	0.00 to 400.0	0.00	0000 to 9C40	0000		
4D	CD	An-07	Frequency reference 7	0.01 Hz	0.00 to 400.0	0.00	0000 to 9C40	0000		
4E	CE	An-08	Frequency reference 8	0.01 Hz	0.00 to 400.0	0.00	0000 to 9C40	0000		
4F	CF	An-09	Jog frequency reference	0.01 Hz	0.00 to 400.0	6.00	0000 to 9C40	0258		

**Note** An-\_\_ setting/reading units differ according to the set values of the Operator display mode (Cn-20). The factory setting is for units of 0.01 Hz.



## 7-5 Changing Constants during Operation bn-\_\_

Set values of bn-\_\_ can be written during operation.

Data Code			Data						Set value	Set value (HEX)
Read (HEX)	Write (HEX)	Data no.	Data name	Setting unit	Setting range	Initial value	Setting range input data	Initial setting (HEX)		
50	D0	bn-01	Acceleration time 1	0.1 sec	0.0 to 6000.0	10.0	0000 to EA60	0064		
51	D1	bn-02	Deceleration time 1	0.1 sec	0.0 to 6000.0	10.0	0000 to EA60	0064		
52	D2	bn-03	Acceleration time 2	0.1 sec	0.0 to 6000.0	10.0	0000 to EA60	0064		
53	D3	bn-04	Deceleration time 2	0.1 sec	0.0 to 6000.0	10.0	0000 to EA60	0064		
54	D4	bn-05	Frequency reference gain	0.1 %	0.0 to 1000.0	100.0 (10 V = 100.0%)	0000 to 2710	03E8		
55	D5	bn-06	Frequency reference bias	1%	-100 to 100	0	009C to 0064	0000		
56	D6	bn-07	Torque compensation gain	0.1	0.0 to 9.9	1.0	0000 to 0063	000A		
57	D7	bn-08	Motor rated slip	0.1%	0.0 to 9.9	0.0	0000 to 0063	0000		
58	D8	bn-09	Energy-saving level gain	1%	0 to 200	80	0000 to 00C8	0050		
59	D9	bn-10	Monitor no. after turning on power supply	1	1 to 3	1	0001 to 0003	0001		
5A	DA	bn-11	Analog Reference Card gain	0.01	0.00 to 2.55	1.00	0000 to 00FF	0064		
5B	DB	bn-12	Analog Reference Card gain	0.01	0.00 to 2.55	0.50	0000 to 00FF	0032		

## 7-6 ENTER Command

After any of the Drive constants (Sn-\_\_, Cn-\_\_, An-\_\_, or bn-\_\_) have been set or modified by write processing from the PLC, the ENTER command must be added at the end. Set "0000" for the write data.

Data Code		Data		
Read (HEX)	Write (HEX)	Data name	Data range	Data range (HEX conversion)
—	FD	ENTER command	0000	0000

# 7-7 Frequency References

Data Code		Data						Set value	Set value (HEX)
Read (HEX)	Write (HEX)	Data name	Setting unit	Setting range	Initial value	Setting range input data	Initial setting (HEX)		
65	E5	Frequency Reference	0.01 Hz	0.00 to 400.00	0.00	0000 to 9C40	0000		
	E6	Frequency Reference (Width)	0.01 Hz	0.00 to 400.00	0.00	0000 to 9C40	0000		

**Note** For writing frequency references, it is not necessary to write an ENTER command.

Frequency Reference, E5, and Frequency Reference (Width), E6 Data codes (write) E5 and E6 are codes for directly specifying the frequency for the GPD 503 AC Drive. Both of these data codes have the same function.

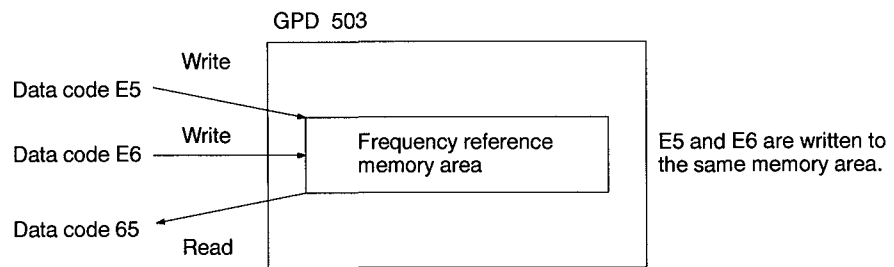

The reason for having two data codes is that if the same data code is used when frequency changes are made continuously, a determination that the transfer is complete cannot be made with a comparison command.

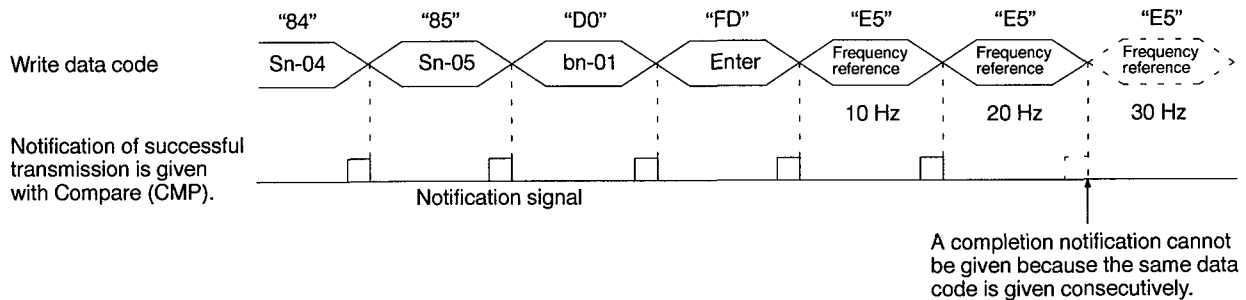

In order to establish the timing (handshaking) for writing data while changing frequencies in order, frequency reference data codes (write) E5 and E6 must be transmitted alternately.

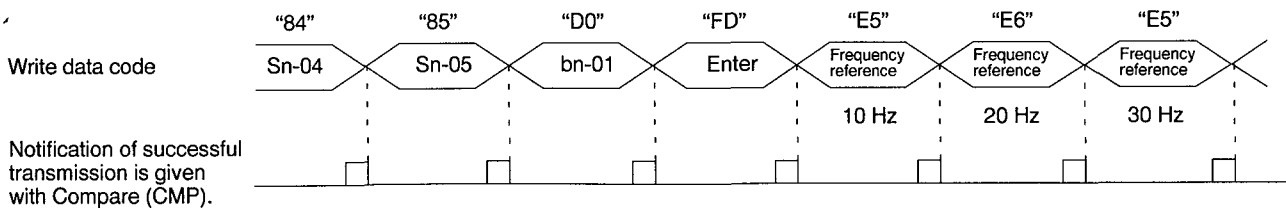

If handshaking is not executed, it is not necessary to alternate E5 and E6. For details, refer to Section 8 Program Examples, program Example 1.

## 7-8 Monitor Display Un-\_\_

Monitor data and Drive status are set using the following data.

### 7-8-1 Monitor Data

Data Code		Data				
Read (HEX)	Write (HEX)	Data no.	Data name	Setting unit	Data range	Data range (HEX conversion)
5C	—	Un-01	Frequency reference	0.01 Hz	0.00 to 400.00	0000 to 9C40
5D	—	Un-02	Output frequency	0.01 Hz	0.00 to 400.00	0000 to 9C40
5E	—	Un-03	Output current	0.1 A	0.0 to 200.0	0000 to 07D0
5F	—	Un-04	Voltage reference	1 V	0 to 500	0000 to 01F4
60	—	Un-05	DC voltage (VPN)	1 V	0 to 800	0000 to 0320
61	—	Un-06	Output power (+ display)	0.1 kW	-100.0 to +100.0	FC18 to 03E8
62	—	Un-07	Input terminal status	—	(Bit signal) 0 to 225	(Bit signal) 0000 to 00FF
63	—	Un-08	Output terminal status	—	(Bit signal) 0 to 7	(Bit signal) 0000 to 0007

### 7-8-2 Drive Status

Data Code		Data		
Read (HEX)	Write (HEX)	Data name	Data range	Data range (HEX conversion)
67	—	Drive status	16-bit data	0000 to ____

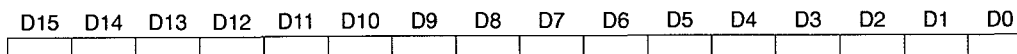

1: ON  
0: OFF

Bit no.	Function	Content
D0	During operation	ON: During operation
D1	Zero speed	ON: Zero speed
D2	Up-to frequency setting	ON: (Frequency ref – Cn-22) ≤ Output frequency ≤ (Frequency ref + Cn-22)
D3	Up-to desired frequency setting	ON: Up-to frequency status (Cn-21 – Cn-22) ≤ Output frequency ≤ (Cn-21 + Cn-22)
D4	Frequency detection 1	ON: Output frequency ≤ Cn-21
D5	Frequency detection 2	ON: Output frequency ≥ Cn-21
D6	Inverter operation ready	ON: Drive operation ready
D7	During undervoltage detection	ON: During undervoltage detection
D8	During output cutoff	ON: During Drive output baseblock
D9	Frequency reference mode	OFF: During operation by frequency reference from communications (when option card is installed). ON: During operation by frequency reference from Drive .
D10	Operation reference mode	OFF: During operation by operation reference from option (when option card is installed). ON: During operation by operation reference from Drive .
D11	Over-torque detection	ON: During over-torque detection
D12	—	—
D13	Braking resistor fault	ON: During braking resistor overheating or braking resistor fault.
D14	Fault	ON: Fault (except CPF00, CPF01)
D15	Not used	0 is output.

## 7-9 Fault Content Monitoring

Data Code		Data		
Read (HEX)	Write (HEX)	Data name	Data range	Data range (HEX conversion)
68	—	Fault content (4 errors)	16-bit data (4 x 4 bits)	0000 to _ _ _ _

### Data Format Example: Order of Error Occurrence

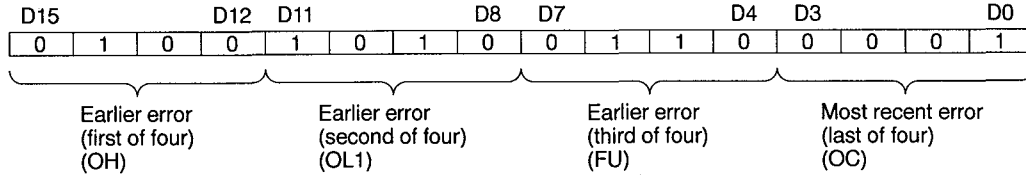

### Fault Contents

Bit no.	Content
0000	No Fault
0001	Over-current (OC)
0010	Over-voltage (OV)
0011	Inverter overload (OL2)
0100	Inverter overheating (OH)
0101	Not used
0110	Fuse break (FU)
0111	Brake transistor fault, Resistor Overheat
1000	External fault (EFxx)
1001	Control circuit fault (CPFxx)
1010	Motor overload (OL1)
1011	Not used
1100	Power failure (including momentary interruptions) (UV1)
1101	Not used
1110	
1111	

Fault contents are cleared (0000) by error reset or power supply reset.

## 7-10 Monitoring Data Link Status

Data Code		Data		
Read (HEX)	Write (HEX)	Data name	Data range	Data range (HEX conversion)
69	—	Data link status	16-bit data	0000 to _ _ _ _

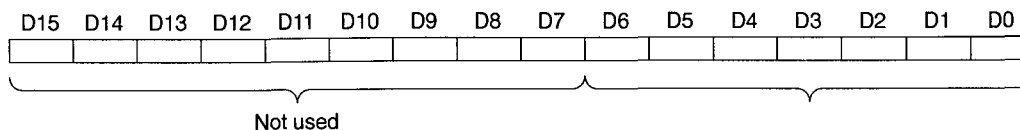

Bit no.	Item	Error content
D0	During data write processing	Data being received.
D1	Write mode error	Wrong data code was received during Inverter operation.
D2	Data code error	An unregistered data code was received.
D3	Setting range error A (Up/down limit error)	Write data was received outside of the setting range.
D4	Setting range error B (Adjustment error)	Write data was received without adjustment (V/f setting, etc.)
D5	NV-RAM write error	NV-RAM writing defect (BCC error)
D6	ENTER command not received	ENTER command was not received after change in constant settings.
D7 to D15	Not used	0 is output.

# SECTION 8

## Program Examples

This program provides programming examples for the GPD 503. Two examples are provided, one for operations in which one code is changed and the second for cases in which two or more codes must be changed.

8-1	Program Example 1 .....	72
8-2	Program Example 2 .....	74

# 8-1 Program Example 1

This is a program for executing only Drive operation references and frequency references.

## System Configuration

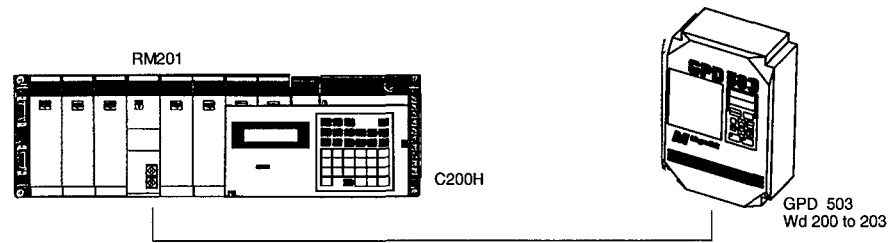

## Operation Pattern

Inputs from contacts (0) to (6) yield the operation pattern shown below.

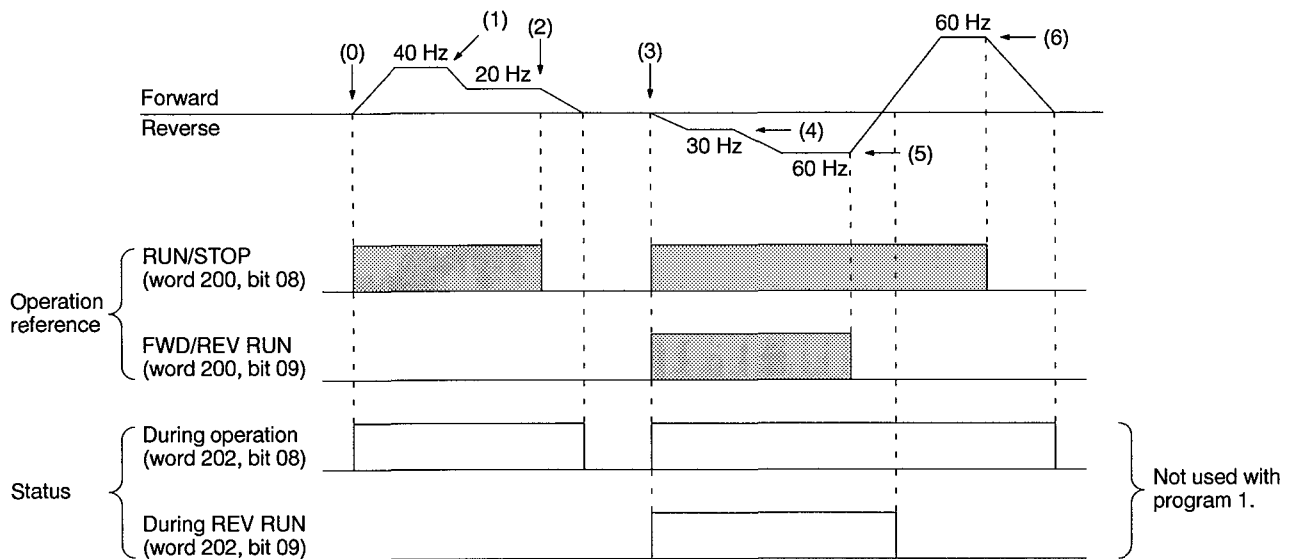

## Program Example

When only the frequency reference is changed by the data code (write), only one data code, E5, is used and there is thus no need to follow a special procedure for handshaking. This makes the program quite simple. When two or more data codes are used, as in the example program shown here, it is necessary to establish the handshake. Refer to *Section 8-2, Program Example 2* for details. This program can be used when performing the following operations.

- 1, 2, 3... 1. Changing two or more data items.
- 2. Changing frequency reference, acceleration time (bn-01), etc.
- 3. Changing data and monitoring.
- 4. Monitoring output frequency and output current values, changing frequency, etc.

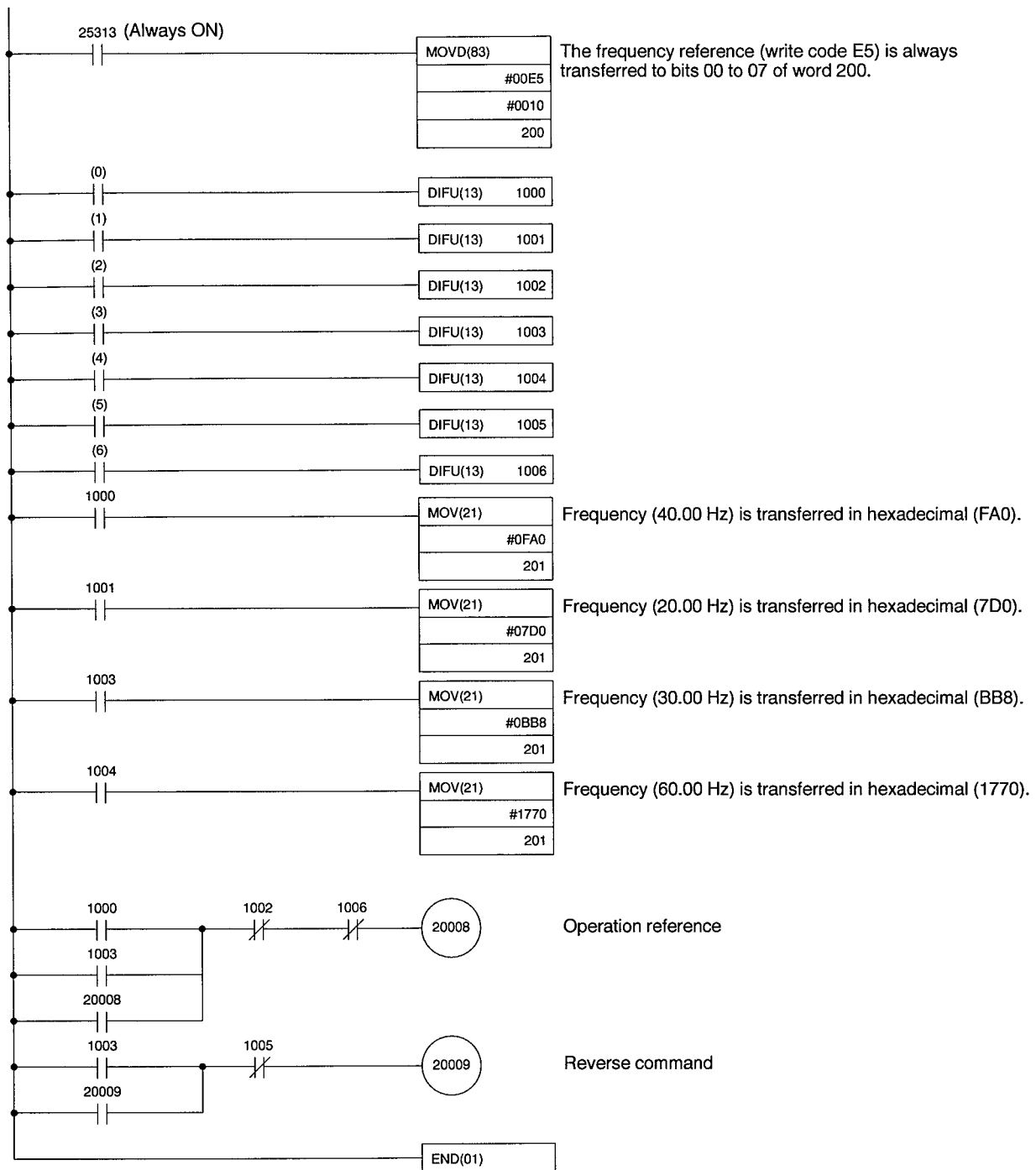



## 8-2 Program Example 2

This is a program for monitoring Sn and Cn data changes, acceleration/deceleration times, and frequency changes, as well as output current (Un-03) and output frequency references (Un-02).

### System Configuration

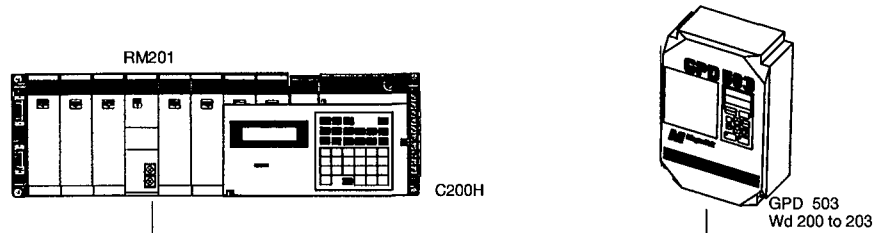

### Operation Pattern

Inputs from contacts (0) to (6) yield the operation pattern shown below.

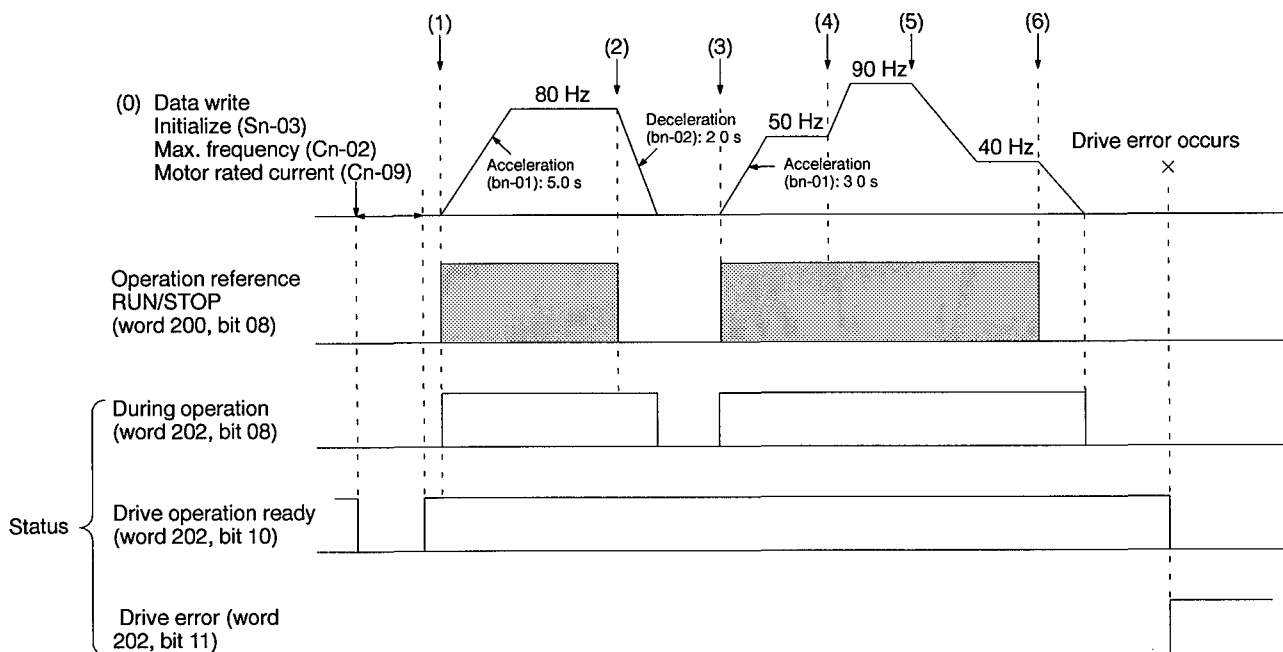

### Program Example

- 1, 2, 3... 1. By turning contact (0) ON and OFF, the seven data items shown below are written from DM 520.

Operation Reference and Write Data

No.	Setting contents	Write data code (HEX)	Write data (HEX)
1	INITIALIZE (Sn-03) = 1110 (000E)	83	000E
2	ENTER command	FD	0000
3	Max. frequency (Cn-02) = 90.0 Hz	9E	0384
4	Motor rated current (Cn-09) = 2.2 A	A5	0016
5	Acceleration time (bn-01) = 5.0 s	D0	0032
6	Frequency reference = 80.00 Hz	E5	1F40
7	ENTER command	FD	0000

2. By turning contact (1) ON and OFF, the operation reference turns ON. The GPD 503 AC Drive will operate with an acceleration speed of 5.0 seconds and a frequency reference of 80.00 Hz.

- By turning contact (2) ON and OFF, the deceleration time data is written from DM 534, and at the same time the operation reference turns OFF.

Deceleration time (bn-02) = 2.0 s      D1      0014  
 ENTER command      FD      0000

- By turning contact (3) ON and OFF, the three data items shown below are written from DM 538, and at the same time the operation reference turns ON.

Acceleration time (bn-01) = 3.0 s      D0      001E  
 Frequency reference = 50.00 Hz      E5      1388  
 ENTER command      FD      0000

- By turning contact (4) ON and OFF, the frequency reference is written from DM 544.

Frequency reference = 90.00 Hz      E5      2328

- By turning contact (5) ON and OFF, the frequency reference is written from DM 546. In this case, there is a possibility that data code E5 (from the frequency reference in the previous step) and the data code in this step will be written consecutively. Therefore data code E6 is used here.

Frequency reference = 40.00 Hz      E6      0FA0

- By turning contact (6) ON and OFF, the operation reference turns OFF and the GPD 503 AC Drive makes a deceleration stop.

**Monitoring**

No.	Monitor contents	Read data code	Remarks
1	Output frequency (Un-02)	5D	Always executed.
2	Output current (Un-03)	5E	
3	Error contents	68	Executed only when an error occurs.

**DM Area Contents**

DM500	Transmitted data code
DM501	Returned data code
DM502	Lead DM no. of write data
DM503	No. of write data items
DM504	Output frequency monitor
DM505	Output frequency monitor
DM506	Output current monitor
DM507	Error content monitor
DM508	Output frequency (HEX)
DM509	0000
DM510	Output current (HEX)

**DM Area Contents**

DM520	0083
DM521	000E
DM522	00FD
DM523	0000
DM524	009E
DM525	0384
DM526	00A5
DM527	0016
DM528	00D0
DM529	0032
DM530	00E5
DM531	1F40
DM532	00FD
DM533	0000
DM534	00D1
DM535	0014
DM536	00FD
DM537	0000
DM538	00D0
DM539	001E
DM540	00E5
DM541	1388
DM542	00FD
DM543	0000
DM544	00E5
DM545	2328
DM546	00E6
DM547	0FA0

Program Diagram

The program will appear as the following:

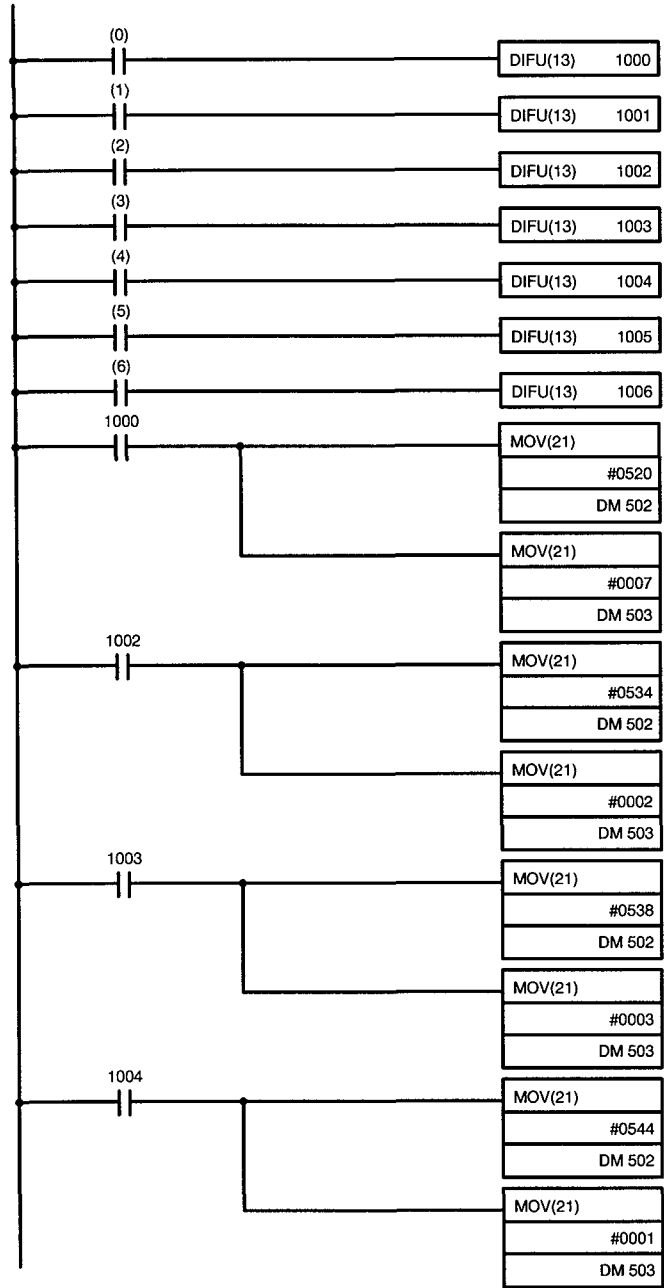

Program Diagram (continued)

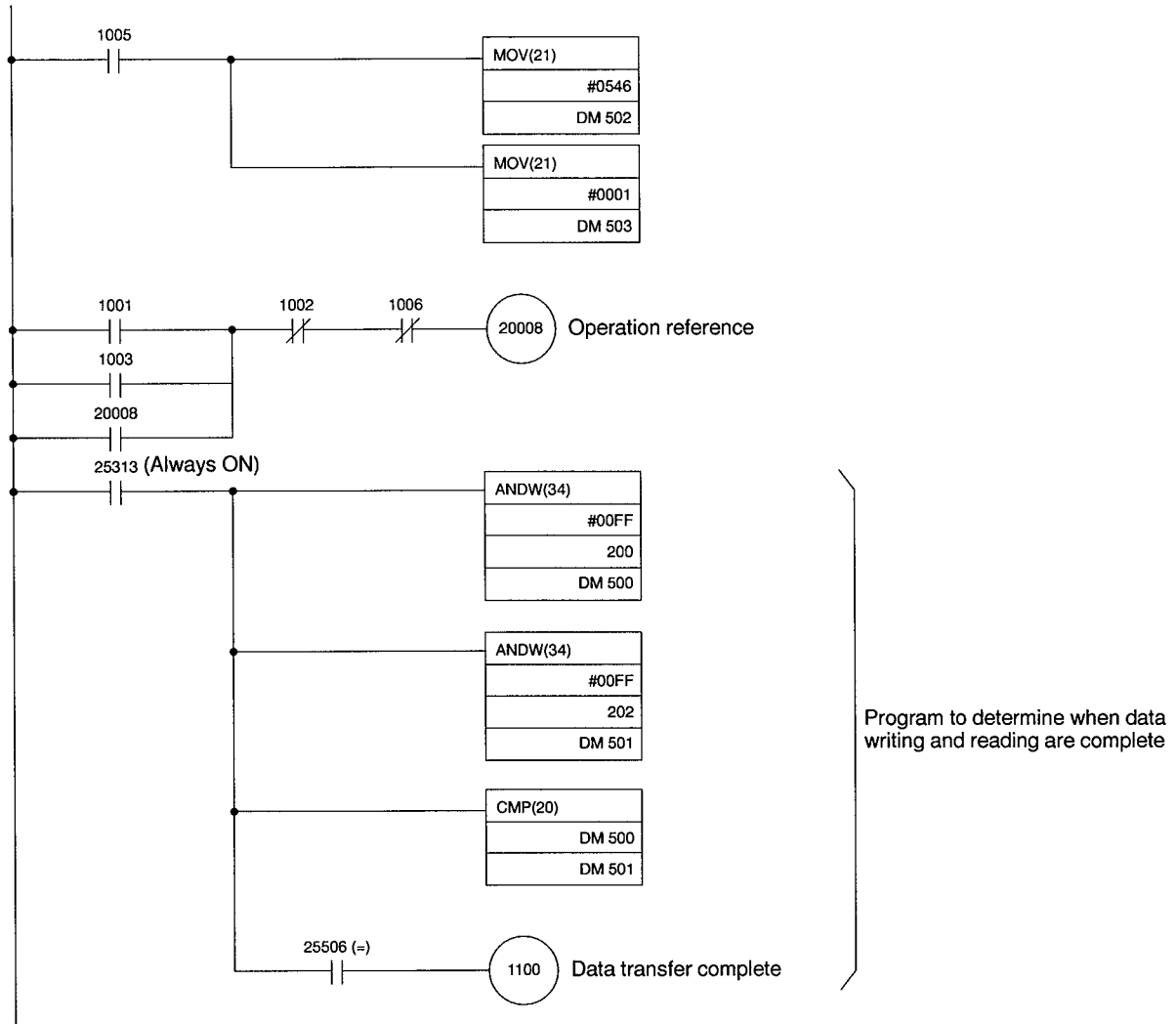

Program Diagram (continued)

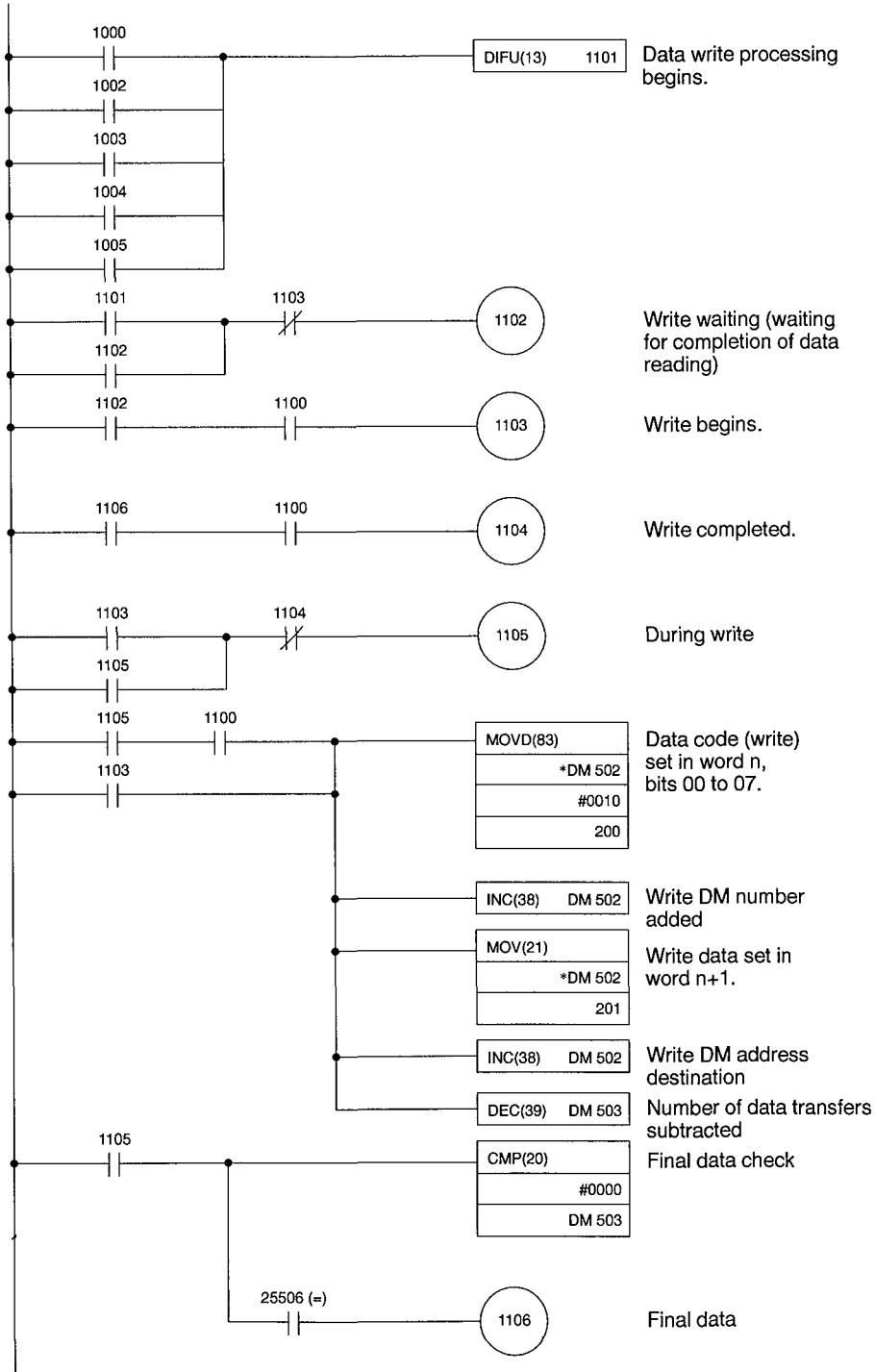

Program for data writing

First DM number of write data is set in DM 502.

The number of write data operations is set in DM 503. When contact 1101 turns ON, the data write processing is executed.

Program Diagram (continued)

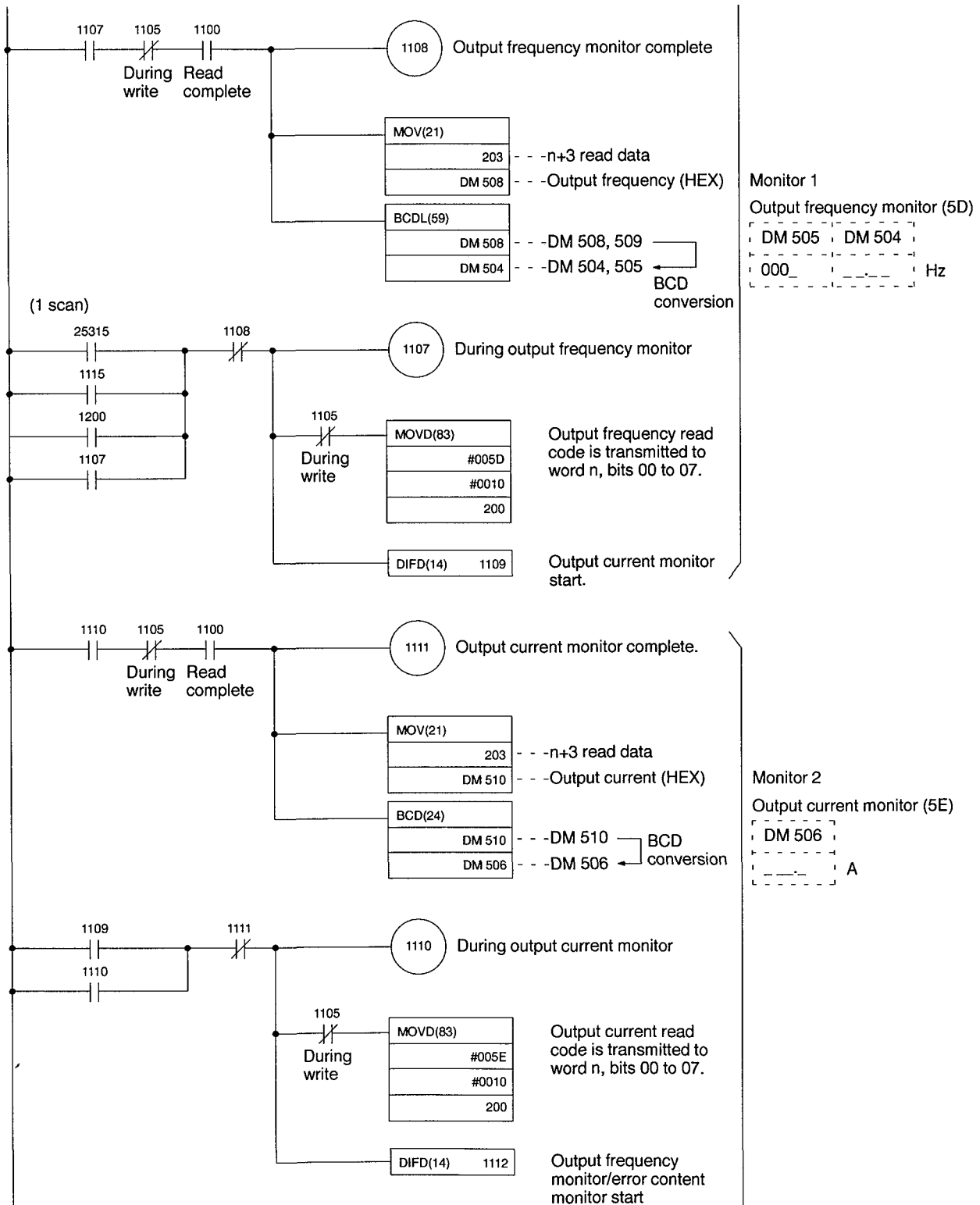

Program Diagram (continued)

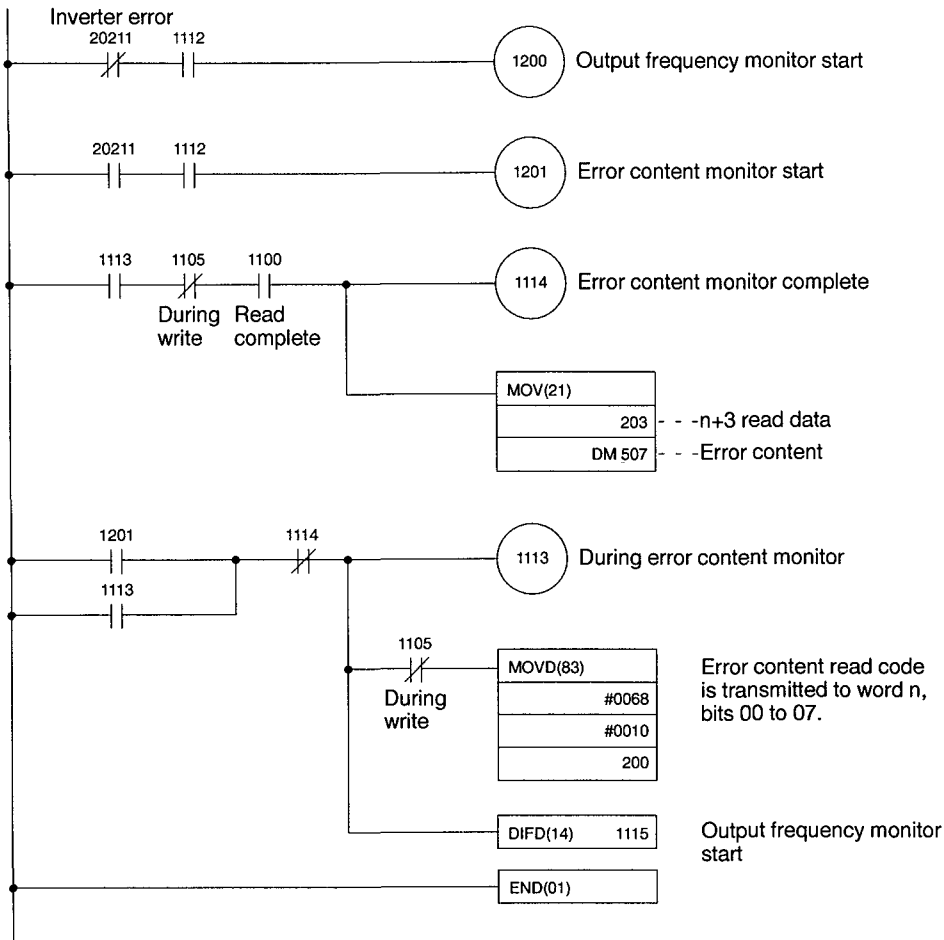

Monitor 3

Error content monitor (58)  
Monitoring only executed  
when drive error (word  
n+2, bit 11) is ON.

Reference the contents of  
DM 503 when contact  
1114 turns ON.



# Index

## A-C

- abbreviations, 2
- changing constants during operations, settings chart, 66
- communication command, additions, 6
- communications
  - methods
    - optical, 3
    - wired, 3
  - pc to drive Unit, 42
  - specifications
    - optical system, 5
    - wired system, 4
- communications priority
  - changing settings, 37
  - system constant settings, 38
- configuration
  - optical system, 5
  - wired system, 4
- connecting drives
  - number per optical system, 5
  - number per wired system, 4
- constants
  - changing during operations, 2
  - control, 2
  - frequency reference, 2
  - monitor display, 2
  - system, 2
- control constant, 2
  - coding chart, 62

## D

- data configuration
  - contents, 28
  - converting bases, 42
  - memory backup, 44
  - monitoring, 30
  - reading, 29
    - monitoring, 47
  - writing, 29
    - procedures, 42
  - writing data and constants, 42
- data exchange, features, 3
- data link status, monitoring, 70
- data setting errors, 52

## E

- ENTER command

- for constants, 66
- processing and constants, 43
- reception error, 44

## F

- fault content monitoring, 69
- frequency reference constant, 2
  - multi-speed chart, 65
- frequency references, 6, 67

## G-L

- I/O points, CV-series, 21
- installation and wiring
  - optical system, 22, 24
  - internal wiring, 23
  - wired system, 15, 16
  - internal wiring, 16
- interface card
  - optical, 2
  - wired, 2
- drives, compatibility with SYSMAC series PCs, 2

## M-N

- master frequency references, external inputs, 38
- modifying data, digital operator, 8
- monitor display constant, 68
  - Unit status, 68
- monitoring
  - capabilities, 3
  - data link status, 31
  - error content, 31
  - drive status, 30
- mult-function commands
  - inputs, 33
  - outputs, 35

## O

occupied words  
  address numbers, relationship, 21  
  number per system, 28  
  switches, relationship, 11  
optical systems, nomenclature and settings, 20

## P-Q

PCs, communicating with, 28  
powering up  
  optical system, 24  
  wired system, 17  
program examples, 72, 74

## R

reading data, precautions, 48  
response time  
  optical system, 50  
  wired system, 50

## S

setting data, additions, 6  
setting switches  
  address number, 20  
  word number, 10  
speed operations, multi-step, 40  
system configuration

optical system, example, 21  
wired system, example, 11

system constant, 2  
  coding chart, 56  
  converting, 62  
system constants, operational references and external inputs, 38

## T

transmission error, Unit operation during, 53  
transmission errors, displays, 7

## U-V

Unit, internal processing time, 49

## W-Z

wired systems, nomenclature and settings, 10  
word allocation, tables, 32  
word numbers, setting  
  example, 13  
  optical system, 20  
  wired system, 10  
word setting, example, 22  
writing data  
  delay time, 49  
  INITIALIZE DATA command, 48  
  precautions, 48  
  program example, 45

# GPD 503 / Sysbus & Sysbus/2

---

Data subject to change without notice GPD is a trademark of MagneTek, Inc SysBus & SysBus/2 are trademarks of Omron.

MagneTek  
16555 W. Ryerson Road  
New Berlin, WI 53151  
(800) 541-0939, (414) 782-0200, FAX (414) 782-3418

