

CNC SYSTEM FOR TURNING APPLICATIONS YASNAC J300L OPERATING MANUAL

Upon receipt of the product and prior to initial operation, read these instructions thoroughly, and retain for future reference.

REFERENCE

YASNAC J300L PROGRAMMING MANUAL TOE-C843-13.21



CONTENTS

FOREWORD	i
NOTES FOR SAFE OPERATION	iii
KEY TO WARNING LABELS	iv

1. OUTLINE OF THE PRODUCT

1.1 OUTLINE OF YASNAC SYSTEM	1 - 2
1.1.1 System Configuration	1 - 2
1.1.2 Environmental Requirements	1 - 4
1.1.3 Machine Operation Panel	1 - 6
1.1.4 General Specifications	1 - 7
1.2 PROTECTIVE FUNCTIONS	1 - 12
1.2.1 Emergency Stop	1 - 12
1.2.2 Overtravel	1 - 12
1.2.3 Stored Stroke Limit	1 - 13
1.2.4 Interlock Inputs	1 - 15

2. BASIC OPERATION OF YASNAC

2.1 GENERAL FLOW OF OPERATION	2 - 3
2.2 INSPECTION BEFORE TURNING THE POWER ON	2 - 4
2.2.1 Inspection of the NC Unit	2 - 6
2.2.2 Inspection of the Tape Reader	2 - 7
2.2.3 Preparation before Turning the Power ON	2 - 8
2.3 TURNING THE POWER ON AND INSPECTION AFTER POWER ON	2 - 9
2.3.1 Procedure for Turning the Power ON	2 - 9
2.3.2 Checking the Motors for Abnormalities	2 - 10
2.3.3 Procedure for Turning the Power OFF	2 - 11
2.3.4 Inspection of the Battery	2 - 12
2.4 MANUAL OPERATION (1)	2 - 15
2.4.1 Manual Rapid Traverse (RAPID)	2 - 15
2.4.2 Jog Feed (JOG)	2 - 16
2.4.3 Step Feed (STEP)	2 - 16
2.4.4 Handle Feed (HANDLE) *	2 - 17

2.5	MANUAL OPERATION (2)	2 - 18
2.5.1	Simultaneous 3-axis Handle Feed *	2 - 18
2.5.2	Manual Reference Point Return	2 - 19
2.5.3	Manual Reference Point Return to the Second Reference Point *	2 - 22
2.5.4	1-line MDI	2 - 23
2.6	AUTOMATIC OPERATION (1)	2 - 24
2.6.1	Preparation of Automatic Operation	2 - 24
2.6.2	Memory Operation	2 - 26
2.6.3	MDI Operation	2 - 27
2.6.4	Feed Hold	2 - 28
2.6.5	Override	2 - 29
2.7	AUTOMATIC OPERATION (2)	2 - 31
2.7.1	Optional Stop	2 - 31
2.7.2	Optional Block Skip	2 - 31
2.7.3	Dry Run	2 - 32
2.7.4	Machine Lock	2 - 33
2.7.5	Auxiliary Function Lock	2 - 33
2.7.6	Feed Hold in Thread Cutting *	2 - 34
2.8	OPERATION INTERVENTION DURING AUTOMATIC OPERATION	2 - 35
2.8.1	Manual Operation Intervention during Automatic Operation	2 - 35
2.8.2	MDI Operation Intervention during Automatic Operation	2 - 36
2.8.3	Automatic Handle Mode Offset *	2 - 37
2.8.4	Manual Absolute	2 - 38
2.9	AUTOMATIC OPERATIONS AT ENHANCED LEVEL	2 - 40
2.9.1	Return to the Setup Point	2 - 40
2.9.2	Return to the Operation Interrupted Point *	2 - 40
2.9.3	Saving the Present Position Data	2 - 42
2.9.4	Program Restart *	2 - 43
3.	BASICS OF DISPLAY AND WRITING OPERATION	
3.1	BASICS OF TERMS RELATED TO OPERATION	3 - 2
3.1.1	Process Screens	3 - 3
3.1.2	Jobs and Functions	3 - 3
3.1.3	YASNAC J300L Function Structure	3 - 4

3.2	NC OPERATION PANEL	3 - 8
3.2.1	Keys and Display Screen on NC Operation Panel	3 - 8
3.2.2	Normal Display on CRT Screen	3 - 15
3.2.3	Pop-up Menu	3 - 20
3.2.4	Key Buffer Edit Function	3 - 21
3.2.5	Buzzer Function	3 - 22

4. EDIT PROCESS OPERATION

4.1	PART PROGRAM EDIT JOB	4 - 3
4.1.1	Calling a Part Program	4 - 4
4.1.2	Editing a Part Program	4 - 7
4.1.3	Saving a Part Program after Editing	4 - 22
4.1.4	Deleting a Part Program	4 - 23
4.2	PART PROGRAM DIRECTORY JOB	4 - 26
4.2.1	Display of the Directory of Part Programs	4 - 26
4.2.2	Calling a Part Program	4 - 33
4.2.3	Deleting a Part Program	4 - 35
4.2.4	Renaming a Part Program	4 - 37
4.2.5	Copying a Part Program	4 - 39
4.3	PART PROGRAM INPUT/OUTPUT AND VERIFY JOB	4 - 40
4.3.1	Inputting a Part Program	4 - 40
4.3.2	Outputting a Part Program	4 - 44
4.3.3	Verifying the Part Programs	4 - 51
4.3.4	Setting the Communication Conditions	4 - 55
4.3.5	Other Function	4 - 60

5. SETUP PROCESS OPERATION

5.1	SETUP JOB	5 - 2
5.1.1	Writing the Tool Offset Data	5 - 2
5.1.2	Clearing the Offset Data	5 - 4
5.2	WORKPIECE COORDINATE SYSTEM SHIFT JOB	5 - 5
5.2.1	Writing the Workpiece Coordinate System Shift Amount	5 - 5
5.2.2	Clearing the Workpiece Coordinate System Shift Amount	5 - 6

5.3	TOOL LIFE CONTROL JOB	5 - 7
5.3.1	Writing the Tool Life Control Data	5 - 7
5.3.2	Displaying the Tool Life Control Data	5 - 7
5.3.3	Setting the Tool Life Control Data	5 - 8
5.3.4	Erasing the Tool Life Control Data	5 - 10

6. RUN PROCESS

6.1	PROGRAM JOB	6 - 3
6.1.1	Program Information Displayed on Screen	6 - 3
6.1.2	Program Number Search	6 - 4
6.1.3	Address Search	6 - 6
6.1.4	Editing the Part Program Stored in Memory	6 - 7
6.1.5	Execution of a Part Program	6 - 9
6.1.6	Display of Subprogram Nesting Information	6 - 10
6.2	MDI OPERATION JOB	6 - 11
6.2.1	Entry of an MDI Program	6 - 11
6.2.2	Editing an MDI Program	6 - 11
6.2.3	Execution of an MDI Program	6 - 12
6.2.4	Deleting an MDI Program	6 - 13
6.2.5	Storing an MDI Program	6 - 13
6.3	COMMAND VALUE DISPLAY JOB	6 - 14
6.3.1	Collective Display of Command Values	6 - 14
6.4	SETTING JOB	6 - 15
6.4.1	Internal Switch Function *	6 - 15
6.4.2	Software Switch Function *	6 - 16
6.4.3	Macro Variable Function	6 - 17
6.4.4	Setting Function	6 - 19

7. COMMON PROCESS OPERATION

7.1	PRESENT POSITION DATA CONTROL JOB	7 - 2
7.1.1	Collective Display of Present Position Data	7 - 2
7.1.2	Display of Present Position Data in the Workpiece Coordinate System	7 - 4
7.1.3	Display of Present Position Data in the External Coordinate Values	7 - 5
7.1.4	Display of Remaining Distance	7 - 6
7.1.5	Setting the Coordinate Systems	7 - 7
7.1.6	Error Pulse Display Function	7 - 9

7.2	ALARM DISPLAY JOB	7 - 10
7.2.1	Alarm Function	7 - 10
7.2.2	Servo Alarm Function	7 - 11
7.2.3	User's Message Function	7 - 12
7.3	TIME CONTROL JOB	7 - 13
7.3.1	Calendar Function	7 - 14
7.3.2	Operating Time Function	7 - 15

8. MAINTENANCE PROCESS

8.1	PARAMETER JOB	8 - 3
8.1.1	Parameter Function	8 - 3
8.1.2	Setting Function	8 - 6
8.1.3	Sequence Parameter Function	8 - 7
8.1.4	Pitch Error Function *	8 - 7
8.2	I/O MONITORING JOB	8 - 8
8.2.1	Displaying the ON/OFF Status of the I/O Signals	8 - 8
8.2.2	Displaying the ON/OFF Status of the Selected I/O Signals	8 - 9
8.2.3	Turning ON/OFF I/O Signals Forcibly	8 - 11
8.3	INPUT/OUTPUT AND VERIFY JOB	8 - 12
8.3.1	Input/output and Verify Function	8 - 12
8.3.2	Reset Function	8 - 14
8.3.3	I/O Device Setting Function	8 - 14
8.4	INTERNAL INFORMATION JOB	8 - 15
8.4.1	Version Number Function	8 - 15
8.4.2	Memory Dump Function	8 - 16
8.4.3	Key Memory Function	8 - 16

9. MAINTENANCE

9.1	MAINTENANCE DATA	9 - 2
9.1.1	Checking the Status of Troubles	9 - 2
9.1.2	Checking the NC Information	9 - 3
9.1.3	Display of Alarm Information	9 - 5
9.1.4	Cause of Alarm and Corrective Action	9 - 6
9.1.5	Troubleshooting (1)	9 - 7
9.1.6	Troubleshooting (2)	9 - 17
9.1.7	Alarms Not Indicated by Alarm Numbers	9 - 23

APPENDIX 1 LIST OF NC INPUT/OUTPUT SIGNALS

APPENDIX 1.1 INPUT SIGNALS (PLC → NC)	A1 - 2
1.1.1 Operation Mode Control	A1 - 2
1.1.2 CNC Part Program Execution Control	A1 - 4
1.1.3 Servo Axis Control	A1 - 5
1.1.4 No. 1 Spindle Control	A1 - 7
1.1.5 No. 2 Spindle Control	A1 - 8
1.1.6 YENET1200 Compatible Inverter Control	A1 - 9
APPENDIX 1.2 OUTPUT SIGNALS (NC → PLC)	A1 - 10
1.2.1 Operation Mode Control	A1 - 10
1.2.2 NC Part Program Execution Control	A1 - 12
1.2.3 Servo Axis Control	A1 - 14
1.2.4 No. 1 Spindle Control	A1 - 17
1.2.5 No. 2 Spindle Control	A1 - 18
1.2.6 YENET1200 Compatible Inverter Control	A1 - 19
1.2.7 Axis Variable Data	A1 - 20

APPENDIX 2 PARAMETER TABLE

APPENDIX 2.1 CLASSIFICATION OF THE PARAMETERS	A2 - 2
APPENDIX 2.2 PARAMETER TABLE	A2 - 3

APPENDIX 3 ALARM TABLE

APPENDIX 3.1 CLASSIFICATION OF ALARMS	A3 - 2
APPENDIX 3.2 ALARM TABLE	A3 - 3

APPENDIX 4 INDEX

FOREWORD

This manual describes cautionary items that must be taken into consideration when operating the YASNAC J300L (with basic NC operation panel, 9-inch CRT) as well as the basic configuration and operation procedure of it.



Some information is presented in tables in the Appendix so that readers can easily find the necessary information. In the specification table, section numbers are given for each specification to allow quick access to a detailed explanation if necessary.

The YASNAC J300L comes with a programming manual in addition to this operating manual. Use these manuals in conjunction with each other to ensure productive operation.

CAUTIONS

This manual describes all the option functions (identified by the “*” symbol) but some of these may not be available with your YASNAC J300M. To determine the option functions installed in your NC, refer to the specification document or manuals published by the machine tool builder.

Unless otherwise specified, the following conditions apply in programming explanations and programming examples.

- Metric system for input and metric system for output/movement
-  : Zero point in the base coordinate system
-  : Reference point

Yaskawa has made every effort to describe individual functions and their relationships to other functions as accurately as possible. However, there are many things that cannot or must not be performed and it is not possible to describe all of these. Accordingly, readers are requested to understand that unless it is specifically stated that something can be performed, it should be assumed that it cannot be performed.

Also bear in mind that the performance and functions of an NC machine tool are not determined solely by the NC unit. The entire control system consists of the mechanical system, the machine operation panel and other machine related equipment in addition to the NC. Therefore, read the manuals published by the machine tool builder for detailed information relating to the machine.

General Precautions

- Some drawings in this manual are shown with the protective cover or shields removed, in order to describe the detail with more clarity. Make sure all covers and shields are replaced before operating this product, and operate it in accordance with the directions in the manual.
- The figures and photographs in this manual show a representative product for reference purposes and may differ from the product actually delivered to you.
- This manual may be modified when necessary because of improvement of the product, modification, or changes in specifications.
Such modification is made as a revision by renewing the manual No.
- To order a copy of this manual, if your copy has been damaged or lost, contact your Yaskawa representative listed on the last page stating the manual No. on the front page.
- If any of the nameplates affixed to the product become damaged or illegible, please send these nameplates to your Yaskawa representative.
- Yaskawa is not responsible for any modification of the product made by the user since that will void our guarantee.

NOTES FOR SAFE OPERATION

Read this operating manual thoroughly before installation, operation , maintenance or inspection of the YASNAC J300L. In this manual, the NOTES FOR SAFE OPERATION are classified as “WARNING” or “CAUTION”.



Indicates a potentially hazardous situation which, if not avoided, could result in death or serious injury to personnel.



Indicates a potentially hazardous situation which, if not avoided, may result in minor or moderate injury to personnel and damage to equipment.

It may also be used to alert against unsafe practice.

Even items described in  may result in a vital accident in some situations. In either case, follow these important items.

KEY TO WARNING LABELS

The following warning labels are used with the YASNAC J300M.



:



Electric shock hazard
Do not touch the terminals while the power is on, and for 5 minutes after switching off the power supply!

Location of label

NC unit

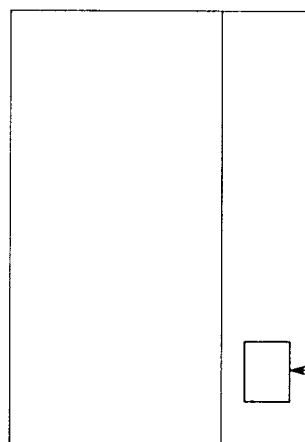

Warning label



Grounding wires must be connected to the unit's grounding terminals.

Location of label

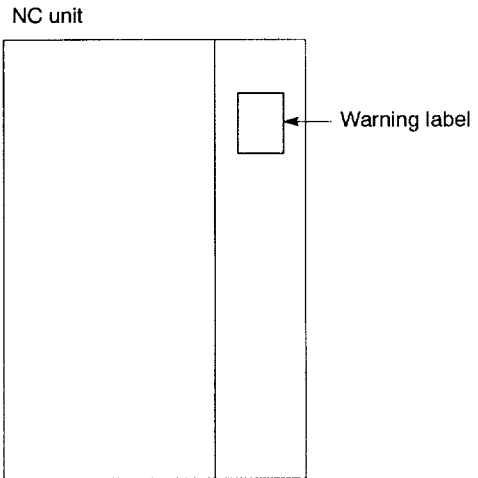

Electric shock hazard
Do not touch inside.

Location of label

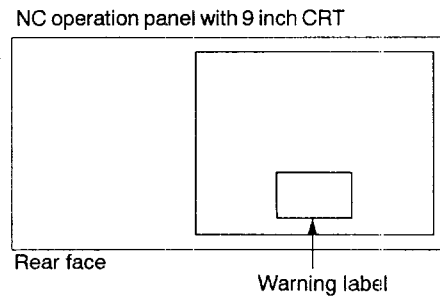

1 STORAGE PRECAUTIONS

 CAUTION	Page
<ul style="list-style-type: none"> Do not store the product in locations subject to rain, water droplets, or harmful gases or liquids. Failure to observe this caution may result in product failure. 	1 - 4
<ul style="list-style-type: none"> Select a storage area indoors that is clean and meets the following temperature and humidity requirements. Failure to observe this caution may result in product failure. Ambient temperature : -20°C to 60°C Relative humidity : 10% to 90% 	1 - 4

2 CAUTIONS ON USE AND OPERATION

 WARNING	Page
<ul style="list-style-type: none"> Do not touch any unit, terminals, etc., while the power is ON. Failure to observe this warning may lead to electric shock or device malfunction. 	2 - 5
<ul style="list-style-type: none"> Immediately after switching the power OFF, the product retains some electric charge. Do not touch any parts which are live when the power is ON for 5 minutes after switching the power OFF. Failure to observe this warning may lead to electric shock or device malfunction. 	2 - 5
<ul style="list-style-type: none"> Do not damage cables, subject them to excessive stress, or pinch them. Excessive load on cables may cause electric shock. 	2 - 5
<ul style="list-style-type: none"> When the unit is turned ON, never touch its rotating parts. Failure to observe this warning may result in personal injury. 	2 - 5
<ul style="list-style-type: none"> Never modify the product. Failure to observe this warning may result in electric shock, fire, or product failure. 	2 - 5

 CAUTION

Page

- | | |
|--|---------------|
| <ul style="list-style-type: none"> • Use the product in an environment with the following characteristics.
Using it in an environment in which it is subject to high temperatures, high humidity, dust, corrosive gases, vibration or impacts may cause fire, electric shock or malfunction. <ul style="list-style-type: none"> · Free from gases or vapors that create a potentially explosive atmosphere. · Free from oil, organic solvents, etc. · Relative humidity in the range 10 to 90% RH, with no condensation. · Ambient temperature in the 0°C to 45°C with no freezing.
(Installation site must not be exposed to direct sunlight, must be distanced from heat generating devices, and must be indoors.) · Vibration not exceeding 4.9 m/s² (0.5 G). | <p>1 - 4</p> |
| <ul style="list-style-type: none"> • Do not let foreign matter such as electric wire scrap enter the unit. Failure to observe this caution may result in fire, product failure or malfunction. | <p>2 - 6</p> |
| <ul style="list-style-type: none"> • Do not restart automatic operation after stopping automatic operation and then performing “tool selection” in manual operation or “1 line MDI” operation.
The reason for this is that the “tool selection” operation may cause the coordinate system to be changed, leading to unexpected operation if automatic operation were restarted. This could cause tool damage due to interference, and resulting accidents involving injuries to personnel.
Reset the NC after any manual intervention. | <p>2 - 37</p> |
| <ul style="list-style-type: none"> • After stopping automatic operation and performing a manual intervention, do not restart automatic operation without resetting first. If automatic operation is started with the “mirror image” or “manual absolute” function in effect, unexpected operation may be performed. This could cause tool damage due to interference, and resulting accidents involving injuries to personnel.
Reset the NC after any manual intervention. | <p>2 - 37</p> |





CAUTION

Page

- | | |
|--|--------|
| <ul style="list-style-type: none">• Before carrying out cutting operation with a new program, confirm safety by performing single block operation and dry run operation. If this check operation is not performed, unexpected operation may be performed due to mis-setting of the amount of offset, leading to tool damage due to interference, and resulting accidents involving injuries to personnel. | 2 - 25 |
| <ul style="list-style-type: none">• The end user must not change parameters relating to machine accuracy, travel axis control and spindle axis control.
The NC parameters are set to the optimum values for each machine, and changing them could therefore result in unexpected operation. This could cause tool damage due to interference, and resulting accidents involving injuries to personnel.
Reset the NC after any manual intervention. | 8 - 3 |
| <ul style="list-style-type: none">• Strictly observe the cautions in the user's manual when using programming functions.
Ignoring these cautions could lead to accidents involving injuries to personnel and malfunctions. | 2 - 25 |
| <ul style="list-style-type: none">• Use the product with the "System Number Switch" of the CPU set to "0".
Use while set to another number may lead to malfunction. | 2 - 10 |
| <ul style="list-style-type: none">• Wait at least 2 seconds after turning the power OFF before turning it ON again.
Failure to observe this caution may lead to malfunction. | 2 - 10 |

3 PRECAUTIONS RELATING TO MAINTENANCE AND INSPECTION

 WARNING	Page
<ul style="list-style-type: none"> • Always turn the power OFF (including the primary power supply) before carrying out daily inspection. Carrying out the inspection with the power ON may lead to electric shock. 	2 - 5
<ul style="list-style-type: none"> • Wait 5 minutes after turning the power (including the primary power supply) OFF before removing or replacing any unit or part. Failure to observe this warning may lead to electric shock and product failure. 	2 - 5
<ul style="list-style-type: none"> • Be sure to turn the power OFF before replacing the battery. Failure to observe this warning may lead to electric shock and product failure. 	2 - 10

 CAUTION	Page
<ul style="list-style-type: none"> • To prevent personnel other than those involved in maintenance and inspection work from turning ON the power while maintenance and inspection is in progress, place signs stating “Do not turn the power on” or words to that effect at the primary power supplies of related control panels and other relevant locations. Failure to observe this caution may lead to electric shock. 	2 - 6
<ul style="list-style-type: none"> • Replace fuses and batteries with the designated products. Failure to observe this caution may result in fire or product failure. 	2 - 10
<ul style="list-style-type: none"> • Electronic devices such as C MOS ICs are used on the control boards. If you touch them with your bare fingers the static electrical charge in your body could destroy them; care must be taken when handling these devices. Before handling these devices for maintenance purposes, first discharge the static electricity in your body by touching a grounded metal device. Failure to observe this caution could lead to injuries and product failure. 	2 - 6
<ul style="list-style-type: none"> • Do not install or remove boards, wiring, connectors, etc., while the power is ON. Failure to observe this caution could lead to electric shock, product failure, and malfunction. 	2 - 6



CAUTION

Page

<ul style="list-style-type: none">• When an alarm occurs, eliminate its cause and confirm safety before resetting it. Failure to observe this caution could result in malfunction.	9 - 2
<ul style="list-style-type: none">• Be sure to check the following points on completing maintenance and inspection work.<ul style="list-style-type: none">• Check that all fastening bolts are tightened.• Check that no tools or other objects have been left inside the control panel.• Check that the control panel door is closed properly.Failure to carry out these checks may lead to electric shock, injuries, fire, and malfunction.	2 - 6
<ul style="list-style-type: none">• For details on trouble relating to the machine-related sequence, refer to the manual issued by the machine tool builder.	9 - 2
<ul style="list-style-type: none">• Never attempt to disassemble or modify units or devices inside the NC unit. Failure to observe this caution may lead to fire, product failure, or malfunction.	2 - 6
<ul style="list-style-type: none">• Do not change the set values of the devices, variable resistors, etc., in the control panel. Failure to observe this caution may lead to fire, product failure, and malfunction.	2 - 6

1

OUTLINE OF THE PRODUCT

Chapter 1 describes the outline of the product and the protective functions that should be thoroughly understood for safe and efficient operation of the YASNAC J300L.

1.1	OUTLINE OF YASNAC SYSTEM	1 - 2
1.1.1	System Configuration	1 - 2
1.1.2	Environmental Requirements	1 - 4
1.1.3	Machine Operation Panel	1 - 6
1.1.4	General Specifications	1 - 7
1.2	PROTECTIVE FUNCTIONS	1 - 12
1.2.1	Emergency Stop	1 - 12
1.2.2	Overtravel	1 - 12
1.2.3	Stored Stroke Limit	1 - 13
1.2.4	Interlock Inputs	1 - 15

1.1 OUTLINE OF YASNAC SYSTEM

1.1.1 System Configuration

The configuration of the YASNAC system and the list of components are described below.

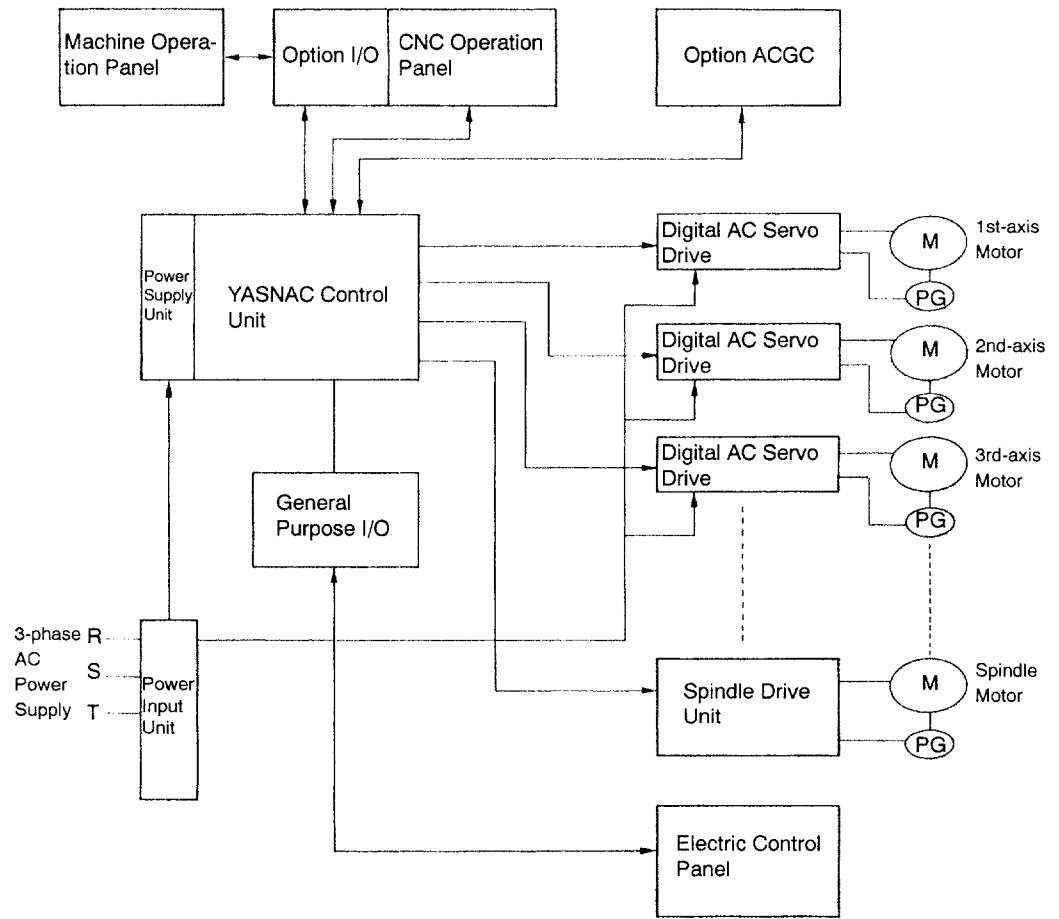

Fig. 1.1 Standard Configuration of YASNAC System

Table 1.1 List of YASNAC System Components

Component Name	Model Name
CPU rack	JZNC-JRK□□
NC operation panel	JZNC-JOP□□
ACGC	JZNC-JOP□□
SERVOPACK	CACR-IR□□
Spindle drive	CIMR-M5
Servomotor	SGMG-□□
Spindle motor	UAASKA-□□
Tape reader	MODEL 2801E
Manual pulse generator	PREH-2E5T/100-M

(3) Vibration

During operation: Max. 4.9 m/s^2 (0.5 G)

(4) Atmosphere

Avoid the following locations:

- Dusty places
- Places where concentration of coolant and/or organic solvent mist is extremely high.

(5) Power Source

Input voltage: AC (single-phase) 200/220/230 V -15 to $+10\%$

Frequency: 50/60 Hz -2 to $+2$ Hz

1.1.3 Machine Operation Panel

An example of machine operation panel is indicated below. Arrangement and names of switches and indicator lamps vary according to the machine model. For details, refer to the manuals published by the machine tool builder.

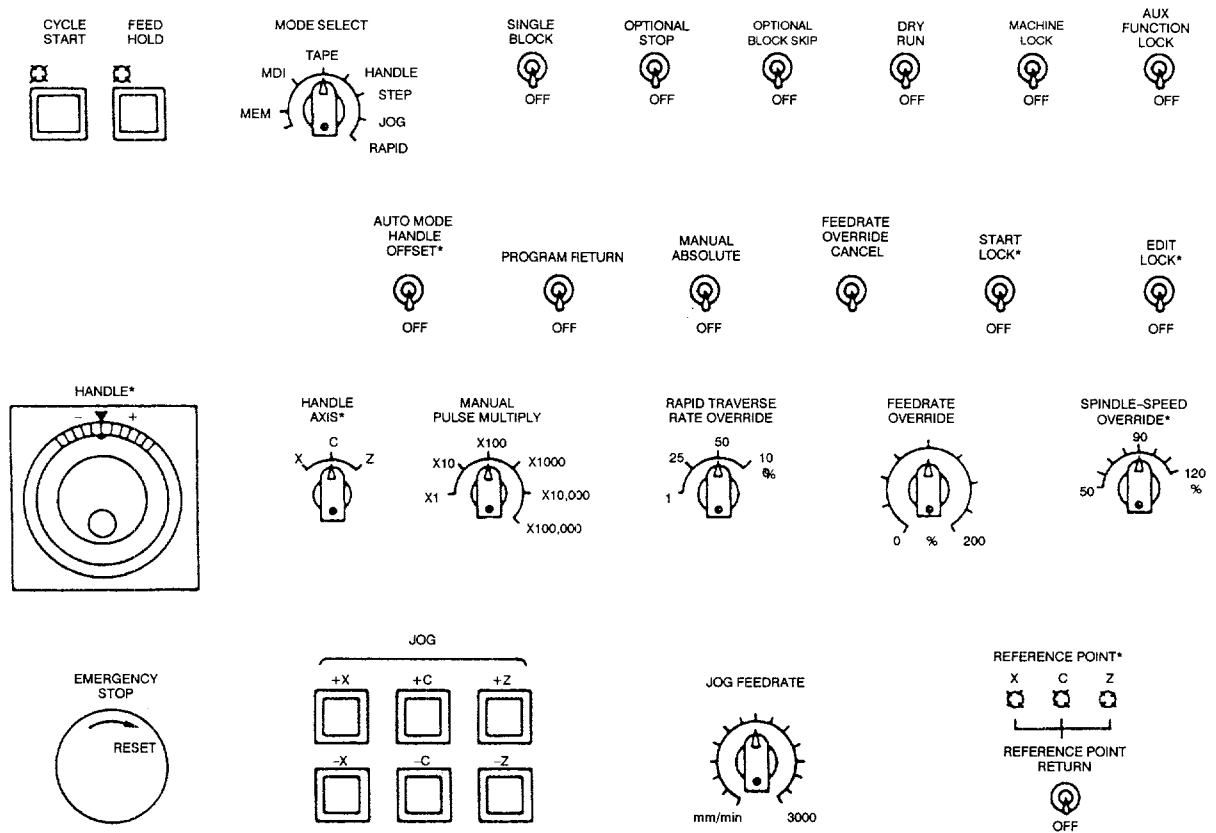

Fig. 1.2 Example of Machine Operation Panel

1.1.4 General Specifications

1

(1) Standard Specifications

Category	Item and Function	Operation Manual	Programming Manual	Section No.
Controlled axes	Controlled axes		✓	1.1.1
	Number of simultaneously controllable axes		✓	1.1.1
Input command	Least input increment		✓	1.1.2
	Least output increment		✓	1.1.2
	Maximum programmable value		✓	1.1.3
	Absolute/incremental programming		✓	3.2.1
	Decimal point input		✓	1.1.5
	Input unit 10 times		✓	1.1.5
	Tape code		✓	1.1.4
	NC tape		✓	1.1.4
	Input format		✓	1.1.5
	Buffer register		✓	1.1.7
Interpolation	Positioning		✓	2.1.1
	Linear interpolation		✓	2.1.2
	Circular interpolation		✓	2.1.3
Feed	Rapid traverse		✓	1.2.1
	Cutting feed		✓	1.2.2
	Dwell		✓	3.3.1
	Changing feed mode – feed per minute and feed per revolution	✓		1.2.5
	Thread cutting	✓		2.2
	Precision thread cutting	✓		2.2.1
	Continuous thread cutting	✓		2.2.1
	Incremental feed	✓		2.3.3
	Automatic acceleration and deceleration		✓	1.2.6
	Rapid feed override		✓	1.2.1
	Cutting feed override		✓	1.2.2
	Override cancel		✓	1.2.7

1

Category	Item and Function	Operation Manual	Programming Manual	Section No.
Storage and editing of program	Program storage capacity	✓		4.1
	Number of programs		✓	1.1.5
	Program editing	✓		4.1.2
	Program number search	✓		6.1.2
	Sequence number search	✓		6.1.2
	Address search	✓		6.1.3
	MDI editing	✓		6.2
Operation and display	Operation panel	✓		3.2.1
	Display function	✓		3.2.1
	Display language	✓		3.2.1
	MDI function	✓		6.2
	1-line MDI	✓		2.4.4
	Operation time display	✓		7.3.2
	Calendar display	✓		7.3.1
	Pop-up menu	✓		3.1.2
	Buzzer function	✓		3.2.3
Input/output function	Input/output interface	✓		8.3.3
Spindle, tool and miscellaneous functions	Spindle function		✓	3.5.1
	Tool function		✓	3.5.2
	Miscellaneous function		✓	3.5.3
Tool offset	Tool position offset		✓	3.4.3
	Number of tool offset data sets		✓	3.4.1
Coordinate system	Manual return to reference point	✓		2.4.2
	Automatic return to reference point		✓	2.2.1
	Automatic return to second reference point		✓	2.2.4
	Reference point return check		✓	2.2.2
	Return from reference point		✓	2.2.3
	Base coordinate system setting		✓	3.1.1

Category	Item and Function	Operation Manual	Programming Manual	Section No.
Operation support function	Label skip		✓	1.1.4
	Single block	✓		2.5.2
	Optional stop	✓		2.6.1
	Optional block skip	✓		1.1.6, 2.6.2
	Dry run	✓		2.6.3
	Machine lock	✓		2.6.4
	Miscellaneous function lock	✓		2.6.5
	Display lock	✓		2.6.4
	Manual absolute	✓		2.7.4
	Numerical value set-up	✓		7.1.5
	Break-point function		✓	4.2.5
	Operation mode	✓		2.3, 2.5
	Feed hold	✓		2.5.4
	Program- ming support function	Canned cycle		✓
Subprogram			✓	4.2.1
Safety and maintenance	Emergency stop input	✓		1.2.1
	Overtravel	✓		1.2.2
	Axis interlock	✓		1.2.4
	Stored stroke limit	✓		1.2.3
	Self-diagnostics (always displayed)	✓		3.2.2
Environment requirements	Power supply	✓		1.1.2
	Ambient temperature	✓		1.1.2
	Humidity	✓		1.1.2

(2) Option Specifications

Category	Item and Function	Operation Manual	Programming Manual	Section No.
Controlled axes	Number of controlled axes		✓	1.1.1
	Rotary axis control		✓	1.1.1
Input command	Least input/output increment of rotary axis		✓	1.1.2
	Inch/metric switching		✓	3.2.2
	Multi-active registers		✓	1.1.7
Interpolation	Polar coordinate interpolation		✓	2.1.7
	Cylindrical interpolation		✓	2.1.6
Feed	Variable lead thread cutting		✓	2.2.3
	Multiple-thread cutting		✓	2.2.2
	Simultaneous 1-axis handle feed	✓		2.3.4
	Simultaneous 3-axis handle feed	✓		2.4.1
Operation and display	Internal toggle switch	✓		6.4.1
	Comment display function		✓	4.2.4
Input/output function and device	Tape reader without take-up reels	✓		1.2.2
	Tape reader with take-up reels	✓		1.2.2
	RS-232C interface	✓		8.3.3
Spindle, tool, and miscellaneous function	Constant surface speed control		✓	3.5.3
	Multiple M codes in a block		✓	3.7.3
Tool offset	Tool radius offset		✓	3.4.4
	Addition of tool offset data sets		✓	3.4.1
	Nose R offset		✓	3.4.3
Coordinate system	Second to fourth reference point return	✓		2.4.3
	Workpiece coordinate system setting		✓	3.1.2
Operation support function	Optional block skip B	✓		2.6.2
	Automatic mode handle offset	✓		2.7.3
	Feed hold in thread cutting		✓	4.1.1
	Return to operation interrupted point	✓		2.8.2

Category	Item and Function	Operation Manual	Programming Manual	Section No.
Program- ming support function	Circular interpolation by R command		✓	2.2.3
	Corner rounding by R command		✓	2.1.4
	Multiple-repetitive cycle		✓	4.1.2
	Hole-machining canned cycle		✓	4.1.5
	Macroprogram		✓	4.4.1
	Programmable mirror image		✓	4.2.4
	Programmable data input		✓	4.2.1
Automation support function	Skip function		✓	4.3.1
	Tool life control function		✓	4.3.2
Safety and maintenance	Stored stroke limit B		✓	4.2.3
	Stored stroke limit C		✓	4.2.3

1.2 PROTECTIVE FUNCTIONS

1.2.1 Emergency Stop

Press the emergency stop button immediately if a problem occurs with the NC or system. The execution of all commands stops instantaneously when the emergency stop button is pressed. Servo power supply of the NC is shut OFF and dynamic brake is applied to stop all mechanical movement. In the emergency stop state, the NC is in the alarm state "3002". In the state the emergency stop signal input (CN02-19 pin on JANCD-JCP03 board) is "opened", the NC stops the entire operation, and turns OFF SVMX (CN2-17 pin on JANCD-JCP03 board) and BKX (CN-18 pin on JANCD-JCP03 board).

1.2.2 Overtravel

The overtravel function stops axis feed operation when an axis reaches the travel limit; for the detection of travel limit, a limit switch and a dog are used and if an axis reaches the travel limit, the limit switch outputs a signal and the function stops axis feed operation in response to this input. The axis reached and stopped at the travel limit can be moved manually into the axis movable range.

When the overtravel input is "opened", axis move is stopped in the manner as indicated in Table 1.1. In response to this input, the alarm output (ALM) is "closed" and the corresponding alarm message is displayed on the screen.

Table 1.2 Axis Stop Direction with Overtravel Input "Opened"

	Manual Operation Mode	Automatic Operation Mode
*+X to *+5 input is "opened"	Movement in the *+X to *+5 direction is stopped.	Movement of all axes is stopped in all directions.
*-X to *-5 input is "opened"	Movement in the *-X to *-5 direction is stopped.	

* Normally closed contact

If the overtravel input is "opened", select the manual mode (jog, pulse handle) and move the axis in the direction opposite to the direction for which the overtravel input is "opened" to "close" the input. After that press the [RESET] key on the NC operation panel, and the alarm output and display are canceled.

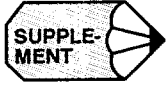

1. After the occurrence of an alarm due to the “open” of the overtravel input, the M, S, and T code read output signals (MF, SF, and TF) are not turned OFF.
2. If it is necessary to interrupt the operation called by M, S, and/or T code, set the interlock by an external sequence.
3. The alarm numbers at the occurrence of overtravel are 2001 to 2005. If the overtravel alarm occurs, axis move is stopped. Note that the servo is not turned OFF.

1

1.2.3 Stored Stroke Limit

To ensure improved safety in operation, the function prevents axes from entering the preset entry prohibited areas both in manual and automatic operation.

(1) Stored Stroke Limit A

The area either inside or outside the boundary specified by parameters or either G36 or G38 is defined as the entry prohibited area. If an axis enters the defined entry prohibited area, an alarm (“2011” to “2015”) occurs. By the setting of “pm5000 D6 = 1”, the entry of an axis into the entry prohibited area does not cause an alarm and only the stroke check monitor output signal (#3640, #3641) is output.

(a) Entry prohibited area

The area outside the boundary set by the parameters for entry prohibited area No. 1 (stored stroke limit A) is defined as the entry prohibited area. Generally, this is used instead of overtravel limit. The parameters set the upper limit point A1 and lower limit point B1.

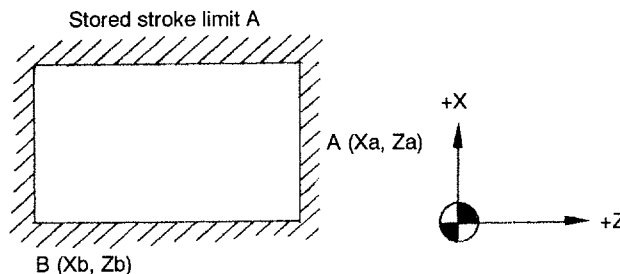

Fig. 1.3 Stored Stroke Limit A

(b) Setting the stored stroke limit A check

Whether or not the stored stroke limit A is made valid is set for the individual axes using the following parameters.

Table 1.3 Valid/Invalid of Stored Stroke Limit A Check

Axis	1st Axis	2nd Axis	3rd Axis	4th Axis	5th Axis
Parameter	pm 6002 D0	pm 6002 D1	pm 6002 D2	pm 6002 D3	pm 6002 D4
Bit Setting	0: Executes stored stroke limit check.				
	1: Does not execute stored stroke limit check.				

(c) Parameters for specifying the boundary of stored stroke limit A

Table 1.4 Parameters for Specifying the Boundary of Stored Stroke Limit A

Axis Name	1st Axis	2nd Axis	3rd Axis	4th Axis	5th Axis
Boundary (+): Point A	pm 6901	pm 6902	pm 6903	pm 6904	pm 6905
Boundary (-): Point B	pm 6911	pm 6912	pm 6913	pm 6914	pm 6915

(2) Stored Stroke Limit B (G36 to G39) *

The area either outside or inside the boundary set by parameters or by the commands in a program is established as the entry prohibited area. The boundary is set with the coordinate values in the machine coordinate system. Whether the entry prohibited area is established outside or inside the boundary can be determined by the setting for a parameter. The function is made valid upon completion of the reference point return after turning ON the power.

Table 1.5 G Code Used to Turn ON/OFF the Stored Stroke Limit B Function

G Code	Function	Group
G36	Turning ON the stored stroke limit B, C (entry prohibited areas No. 2 to No. 5)	07
G37	Turning OFF the stored stroke limit B, C (entry prohibited areas No. 2 to No. 5)	07
G38	Turning ON the stored stroke limit C (entry prohibited area No. 3)	08
G39	Turning OFF the stored stroke limit C (entry prohibited area No. 3)	08

- In addition to the stored stroke limit A, stored stroke limits B and C can be added.
- With the stored stroke limits B and C, set the boundary of the area and inside or outside the boundary by parameters.
- According to the setting for the parameter, either of stored stroke limits B and C can be made valid.
- For details of the stored stroke limit B, refer to 4.2.3 “Subprogram Call Up Function (M98, M99)” in the PROGRAMMING MANUAL.

1.2.4 Interlock Inputs

The interlock input is the signal used to disable axis movement, and is provided for each axis.

- When an axis is interlocked during movement, it is stopped after deceleration.
- When the interlock is released, the axis continues moving to complete the remaining commands. Upon completion of the commands, the program advances to the next block.
- For simultaneous three axis interpolation commands, interpolation operation is disabled if one of these two or three axes is interlocked.

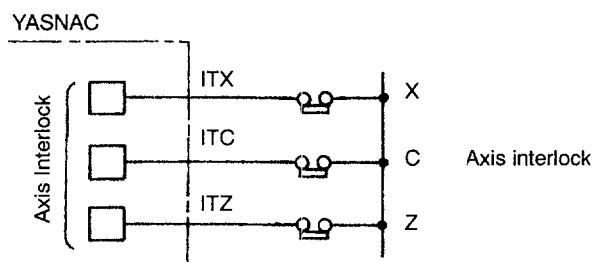

Fig. 1.4 Interlock Inputs

2

BASIC OPERATION OF YASNAC

2

Chapter 2 describes various kinds of operations including power ON procedure, manual operation, and automatic operation.

2.1	GENERAL FLOW OF OPERATION	2 - 3
2.2	INSPECTION BEFORE TURNING THE POWER ON	2 - 4
2.2.1	Inspection of the NC Unit	2 - 6
2.2.2	Inspection of the Tape Reader	2 - 7
2.2.3	Preparation before Turning the Power ON	2 - 8
2.3	TURNING THE POWER ON AND INSPECTION AFTER POWER ON	2 - 9
2.3.1	Procedure for Turning the Power ON	2 - 9
2.3.2	Checking the Motors for Abnormalities	2 - 10
2.3.3	Procedure for Turning the Power OFF	2 - 11
2.3.4	Inspection of the Battery	2 - 12
2.4	MANUAL OPERATION (1)	2 - 15
2.4.1	Manual Rapid Traverse (RAPID)	2 - 15
2.4.2	Jog Feed (JOG)	2 - 16
2.4.3	Step Feed (STEP)	2 - 16
2.4.4	Handle Feed (HANDLE)*	2 - 17

- 2.5 MANUAL OPERATION (2) 2 - 18
 - 2.5.1 Simultaneous 3-axis Handle Feed * 2 - 18
 - 2.5.2 Manual Reference Point Return 2 - 19
 - 2.5.3 Manual Reference Point Return
to the Second Reference Point * 2 - 22
 - 2.5.4 1-line MDI 2 - 23
- 2.6 AUTOMATIC OPERATION (1) 2 - 24
 - 2.6.1 Preparation of Automatic Operation 2 - 24
 - 2.6.2 Memory Operation 2 - 26
 - 2.6.3 MDI Operation 2 - 27
 - 2.6.4 Feed Hold 2 - 28
 - 2.6.5 Override 2 - 29
- 2.7 AUTOMATIC OPERATION (2) 2 - 31
 - 2.7.1 Optional Stop 2 - 31
 - 2.7.2 Optional Block Skip 2 - 31
 - 2.7.3 Dry Run 2 - 32
 - 2.7.4 Machine Lock 2 - 33
 - 2.7.5 Auxiliary Function Lock 2 - 33
 - 2.7.6 Feed Hold in Thread Cutting * 2 - 34
- 2.8 OPERATION INTERVENTION
DURING AUTOMATIC OPERATION ... 2 - 35
 - 2.8.1 Manual Operation Intervention
during Automatic Operation 2 - 35
 - 2.8.2 MDI Operation Intervention
during Automatic Operation 2 - 36
 - 2.8.3 Automatic Handle Mode Offset * 2 - 37
 - 2.8.4 Manual Absolute 2 - 38
- 2.9 AUTOMATIC OPERATIONS
AT ENHANCED LEVEL 2 - 40
 - 2.9.1 Return to Setup Point 2 - 40
 - 2.9.2 Return to the Operation Interrupted Point * . 2 - 40
 - 2.9.3 Saving the Present Position Data 2 - 42
 - 2.9.4 Program Restart * 2 - 43

2.1 GENERAL FLOW OF OPERATION

The operation procedure usually followed for daily operation is indicated in Fig. 2.1. This Chapter gives explanation on these operation items.

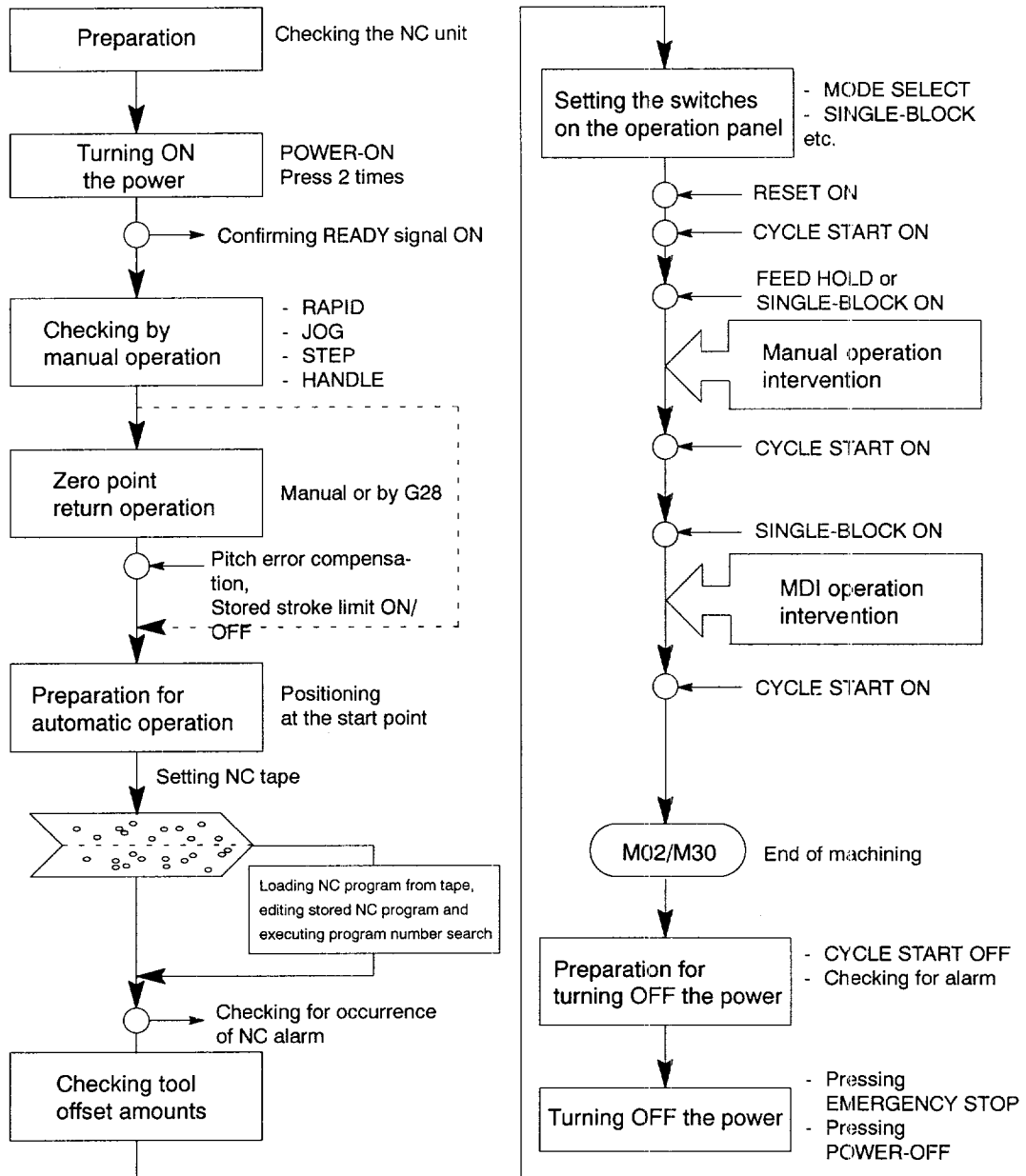

2

Fig. 2.1 Operation Procedure

2.2 INSPECTION BEFORE TURNING THE POWER ON

Before turning the power ON for YASNAC J300, it is necessary to carry out inspection to ensure safety. If the power is turned ON while the system has troubles, it could cause malfunctioning of the system itself as well as hazards to the operators. Make sure to carry out daily inspection before turning the power ON.



WARNING

- Always turn the power OFF (including the primary power supply) before carrying out daily inspection.
Carrying out the inspection with the power ON may lead to electric shock.
- Wait 5 minutes after turning the power (including the primary power supply) OFF before removing or replacing any unit or part.
Failure to observe this warning may lead to electric shock and product failure.
- Do not touch any unit, terminals, etc., while the power is ON.
Failure to observe this warning may lead to electric shock or device malfunction.
- Immediately after switching the power OFF, the product retains some electric charge. Do not touch any parts which are live when the power is ON for 5 minutes after switching the power OFF.
Failure to observe this warning may lead to electric shock or device malfunction.
- Do not damage cables, subject them to excessive stress, or pinch them.
Excessive load on cables may cause electric shock.
- When the unit is turned ON, never touch its rotating parts.
Failure to observe this warning may result in personal injury.
- Never modify the product.
Failure to observe this warning may result in electric shock, fire, or product failure.

 **CAUTION**

- To prevent personnel other than those involved in maintenance and inspection work from turning ON the power while maintenance and inspection is in progress, place signs stating “Do not turn the power on” or words to that effect at the primary power supplies of related control panels and other relevant locations. Failure to observe this caution may lead to electric shock.
- Electronic devices such as C MOS ICs are used on the control boards. If you touch them with your bare fingers the static electrical charge in your body could destroy them; care must be taken when handling these devices. Before handling these devices for maintenance purposes, first discharge the static electricity in your body by touching a grounded metal device. Failure to observe this caution could lead to injuries and product failure.
- Do not install or remove boards, wiring, connectors, etc., while the power is ON. Failure to observe this caution could lead to electric shock, product failure, and malfunction.
- Do not let foreign matter such as electric wire scrap enter the unit. Failure to observe this caution may result in fire, product failure or malfunction.
- Be sure to check the following points on completing maintenance and inspection work.
 - Check that all fastening bolts are tightened.
 - Check that no tools or other objects have been left inside the control panel.
 - Check that the control panel door is closed properly.Failure to carry out these checks may lead to electric shock, injuries, fire, and malfunction.
- Never attempt to disassemble or modify units or devices inside the NC unit. Failure to observe this caution may lead to fire, product failure, or malfunction.
- Do not change the set values of the devices, variable resistors, etc., in the control panel. Failure to observe this caution may lead to fire, product failure, and malfunction.

2.2.1 Inspection of the NC Unit

In this subsection, the items to be inspected before turning ON the power are indicated for the standard NC box supplied by Yaskawa. For the control box specific to the machine tool, refer to the manuals published by the machine tool builder.

(1) Inspecting the Doors

Make sure that the doors are securely closed before turning the power ON.

The NC box is completely shielded to keep outside air out to protect the precision devices in the NC box from oil mist or other airborne foreign matter. The doors of the NC box must always be kept closed.

(2) Inspecting the Shielding Parts

Inspect the shielding parts in the NC box every month for gaps and/or damages.

- ① Open the doors and check the packings which are installed around the door for damage.
- ② Inspect the inside of the NC box for abnormal contamination. If the inside is abnormally dirty, clean it immediately after locating the cause of contamination.
- ③ Lock the doors securely and inspect the doors to make sure that there are no gaps.

By carrying out the inspection indicated above at regular intervals, performance of YASNAC J300 can be maintained for a long period.

2.2.2 Inspection of the Tape Reader

If the tape reader is dirty or does not operate smoothly, it could cause malfunctioning of the NC. Inspect and clean the tape reader from time to time.

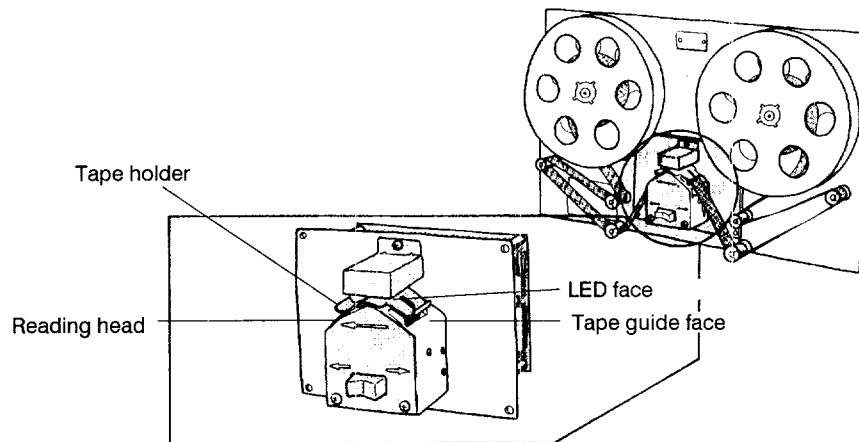

2

Fig. 2.2 Tape Reader

- ① Clean the glass in the reading head by removing tape chips and dust with a soft brush. If oily stain is found, wipe it off with clean gauze or soft cloth soaked with absolute alcohol. Clean both the tape guide face and tape holder at the same time.
- ② If dust is found on the LED face in the upper light source, clean it with soft brush.
- ③ For the tape reader equipped with 6-inch or 8-inch tape take-up reels, if tension arm movement seems to be heavy, apply a small amount of machine oil to the shaft base portion.

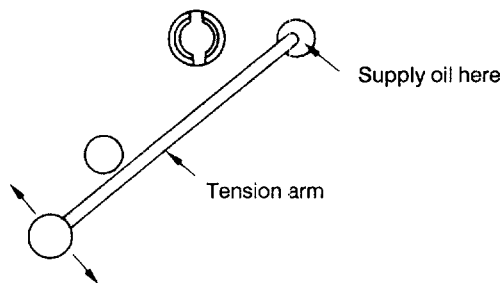
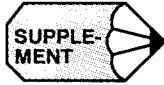

Fig. 2.3 8-inch Take-up Reel



If a problem occurs with tape winding or tape feed operation with the tape reader equipped with 8-inch tape reels, open the front door, and clean the area around the photocoupler located near the reel drive motor.

2

2.2.3 Preparation before Turning the Power ON

Before turning the power ON, confirm the following items.

- Make sure that both the front and rear sides of the NC unit are closed. If the door is open or if there is a gap between the door and the box panels, securely close the door using the door lock.
- Carry out the inspection for the machine and machine related controllers according to the instructions given in the manuals published by the machine tool builder.

2.3 TURNING THE POWER ON AND INSPECTION AFTER POWER ON

In this section, the procedure to be used for turning the power ON is explained. Inspection that must be conducted after turning the power ON is also described.



WARNING

- Be sure to turn the power OFF before replacing the battery.
Failure to observe this warning may lead to electric shock and product failure.



CAUTION

- Replace fuses and batteries with the designated products.
Failure to observe this caution may result in fire or product failure.
- Use the product with the "System Number Switch" of the CPU set to "0".
Use while set to another number may lead to malfunction.
- Wait at least 2 seconds after turning the power OFF before turning it ON again.
Failure to observe this caution may lead to malfunction.

2

2.3.1 Procedure for Turning the Power ON

Turn the power ON in the following procedure.

- ① Make sure that the power is supplied to the NC unit from an external power source.
- ② Press the POWER ON button on the NC operation panel. Control power is turned ON and the cooling fan starts rotating.
- ③ Make sure that air is flowing out at the upper part on the side of the NC unit.
 - In approximately 20 seconds, the control is ready for turning ON the servo power (alarm code 3000).
- ④ Press the POWER ON button once again.
 - The servo power is turned ON. When the machine is ready for operation, the NC enters the ready state.
 - When the power is correctly turned ON to the NC unit, the NRD (NC ready) signal is output.

- When the power is turned ON at the machine side in response to the NRD signal, the MRD (machine ready) signal will be returned to the NC. The READY lamp goes on when the MRD signal is returned. Note that the READY lamp is not used with some types of machines.
 - When the NC unit enters the ready state, the alarm message displayed on the screen will go off.
- ⑤ If the NC unit fails to enter the ready state, locate the cause by referring to Section 7.2, “ALARM DISPLAY JOB”, and take appropriate measures. For turning the power ON, there are items that must be inspected at the machine side in addition to the NC unit related items. For such items, refer to the manuals published by the machine tool builder.

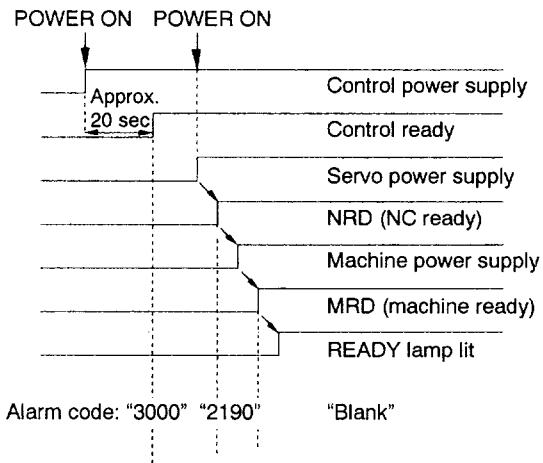

Fig. 2.4 Power ON Sequence

2.3.2 Checking the Motors for Abnormalities

Check the motors for their operation. If abnormal vibration or noise is found, turn OFF the power and contact the maintenance personnel.

2.3.3 Procedure for Turning the Power OFF

Turn the power OFF in the following procedure.

- ① Make sure that the CYCLE START lamp on the machine operation panel is OFF with the machine stopped.
- ② Make sure that there is no alarm message displayed on the CRT screen. If an alarm message is displayed, locate the cause by referring to Section 7.2, “ALARM DISPLAY JOB” and take appropriate measures to clear it.
- ③ Carry out inspection necessary for turning the power OFF at the machine side. For details, refer to the manuals published by the machine tool builder.
- ④ Press the EMERGENCY STOP button on the machine operation panel to turn OFF the servo power.
- ⑤ Press the POWER OFF button on the NC operation panel to shut off the power to the control panel.
- ⑥ Turn the power supply to the NC OFF by turning OFF such as a circuit breaker.

2

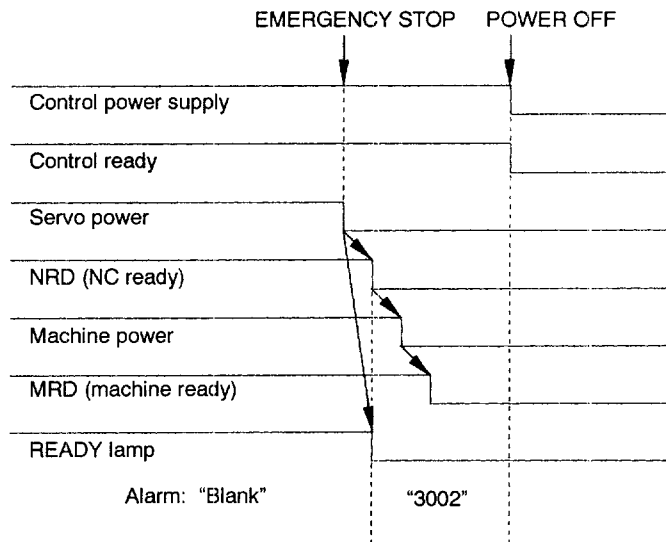
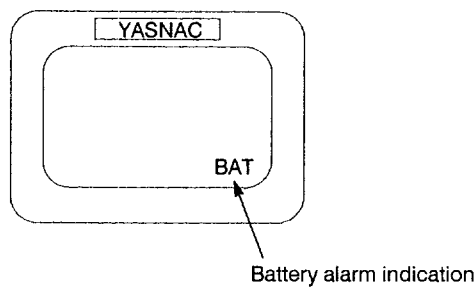

Fig. 2.5 Power OFF Sequence

2.3.4 Inspection of the Battery

After turning the power ON, check the CRT screen if "BAT" message is blinking at the lower right area. If it is displayed, it indicates that the battery is weakening. The battery must be replaced within one month. If the display of "BAT" message is given, make sure to leave the NC unit power ON at least one hour every three days.



Standard batteries cannot be used. For a spare battery, contact your Yaskawa representative. Battery type: ER6VC3, Parts code: BA507

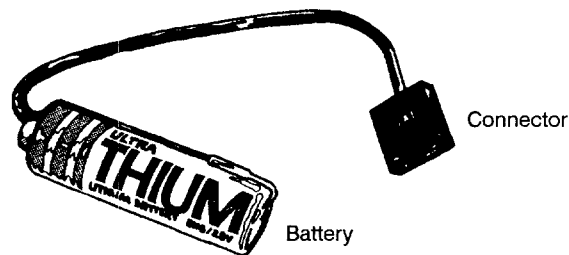

The location of battery and related indicator (LED) is shown in Fig. 2.5.

(1) Checking the Battery Which Needs Replacing

Follow the procedure indicated below to check whether or not battery must be replaced.

- ① Press the POWER OFF button.
- ② If a door interlock switch is installed, place the door interlock key in the OFF position. This makes power ON possible with the door opened.
- ③ Open the door so that the front part of the NC unit is visible.
- ④ Press the POWER ON button once again.
- ⑤ Check the red LED on the JCP01 board. If it is lit, the battery must be replaced.

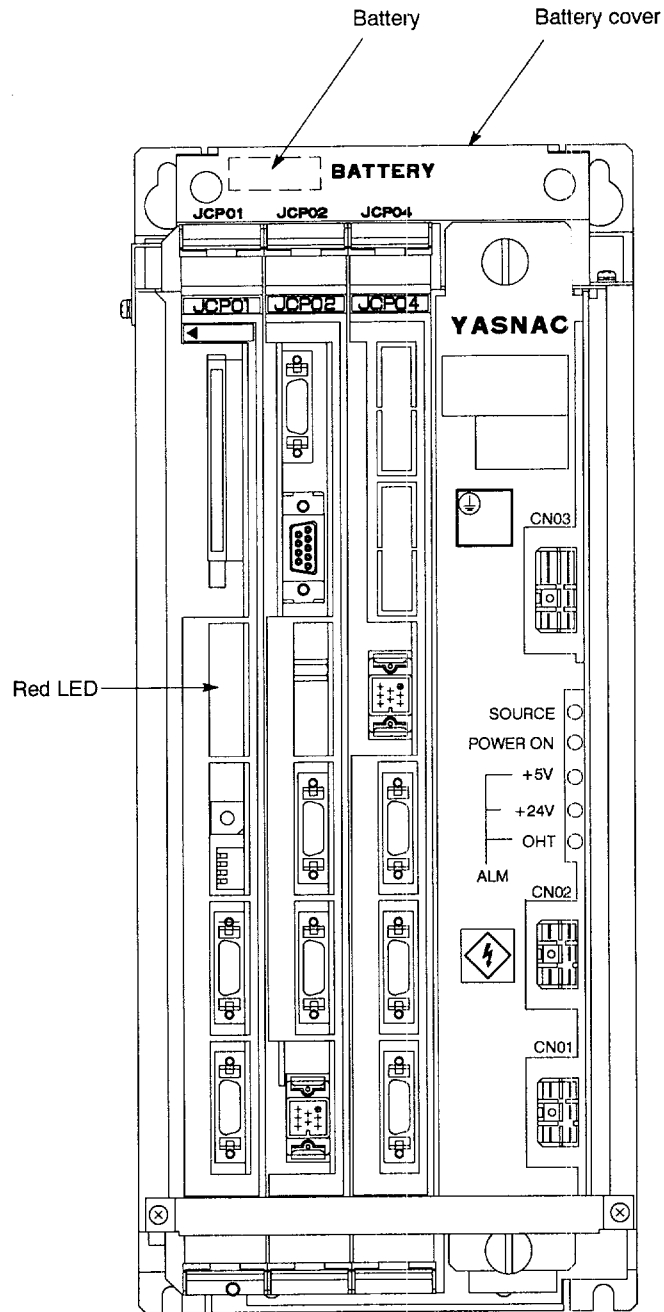

2

Fig. 2.6 Arrangement of Battery and Indicator Lamp (LED)

(2) Replacing the Battery

Replace the battery quickly in the following procedure.

- ① Turn the power OFF.
- ② Remove the battery cover by prying it up with a screwdriver. Then, remove the battery from the holder.
- ③ Fit the new battery in the holder and insert the connector. Although the connector may be inserted in either direction, it must be securely inserted. Otherwise, the power will not be supplied by the battery. (See Fig. 2.7.)

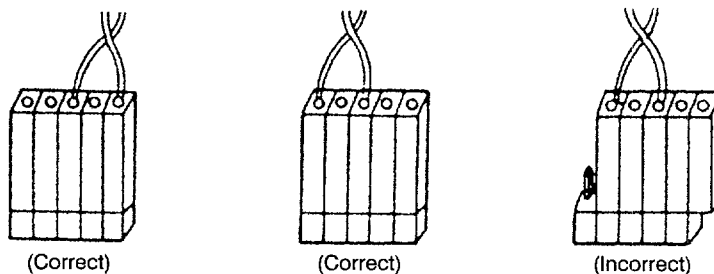

Fig. 2.7 Connecting the Battery Connector

- ④ Turn the power ON.
- ⑤ Make sure that “BAT” is not blinking on the CRT screen and that the red LED in the board is OFF.



1. If the red LED remains lit after replacing the battery, the connector might be inserted incorrectly or the battery might be faulty.
2. Power OFF operation is allowed a few seconds after turning the power ON.
3. After turning the power OFF, replace the battery quickly. If the NC unit is left with the battery removed, the data stored in the memory could be lost.
4. If the NC unit has two battery packs, replace both of battery packs at the same time. Note that the date of manufacture of the battery packs to be installed newly should be as close to each other as possible. If the battery packs manufactured in different years are used, the service lives of them will be shortened and in the worst case, the life will be that of a single pack.

2.4 MANUAL OPERATION (1)

This section describes general explanation on manual operation. To move an axis manually, select the operation mode of RAPID, JOG, STEP or HANDLE with the MODE SELECT switch on the machine operation panel.

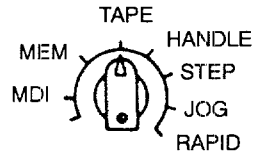

2

2.4.1 Manual Rapid Traverse (RAPID)

An axis can be moved at a rapid traverse rate. Follow the procedure indicated below.

- ① Select the rapid mode by placing the MODE SELECT switch on the machine operation panel in the RAPID position.
- ② Select the feedrate to be used for axis feed operation by the RAPID TRAVERSE RATE OVERRIDE switch on the machine operation panel.
 - Override setting is possible in four steps of 100%, 50%, 25%, and F_0 . The feedrate corresponding to the setting at 100%, 50%, and 25% is set for parameters pm2801 to pm2805. For the setting at F_0 , feedrate set for parameter pm2447 is used.
 - Optionally, F_1 and F_2 positions are selectable. Feedrate to be selected according to the switch setting at F_1 and F_2 is set for parameters pm2448 and pm2449.
- ③ On the machine operation panel, press the JOG button that corresponds to the axis and the direction in which the axis should move. The axis moves at a rapid traverse rate while the button is held pressed.

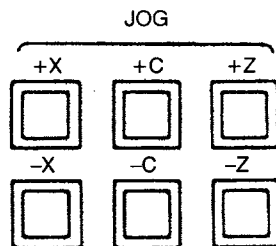

2.4.2 Jog Feed (JOG)

It is possible to move an axis in the jog feed mode. Follow the procedure indicated below.

- ① Select the jog mode by placing the MODE SELECT switch on the machine operation panel in the JOG position.
- ② Select the feedrate with the JOG FEEDRATE switch on the machine operation panel.
 - Feedrate can be selected from 32 steps, with actual feedrates of individual setting positions set for parameters pm2400 to pm2431. The actual number of steps and feedrates selectable by the JOG FEEDRATE switch vary depending on the machine model. For details, refer to the manuals published by the machine tool builder.
- ③ Press the JOG switch corresponding to the axis to be moved and the required axis move direction.
- ④ The axis moves at the selected feedrate while the JOG switch is held pressed.

2.4.3 Step Feed (STEP)

Manual step feed operation is possible. Follow the procedure indicated below.

- ① Select the step mode by placing the MODE SELECT switch on the machine operation panel in the STEP position.
- ② Select the feed distance per step with the MANUAL PULSE MULTIPLY switch on the machine operation panel.
 - Metric system : 0.001, 0.01, 0.1, 1.0, 10.0, 100.0 mm (per step)
 - Inch system : 0.0001, 0.001, 0.01, 0.1, 1.0, 10.0 inch (per step)
- ③ Press the JOG switch corresponding to the axis to be moved and the required axis move direction.
- ④ Each time the JOG switch is pressed, the selected axis moves in the selected direction by the set feed distance per step.

2.4.4 Handle Feed (HANDLE) *

When the NC is equipped with a manual pulse generator, pulse handle feed operation is possible. Follow the procedure indicated below.

- ① Select the handle mode by placing the MODE SELECT switch on the machine operation panel in the HANDLE position.
- ② Select the axis to be moved by the HANDLE AXIS selection switch on the machine operation panel.
- ③ With the MANUAL PULSE MULTIPLY switch on the machine operation panel, select the axis feed distance per pulse (one division of the pulse handle).
Clockwise rotation: In the positive direction
Counterclockwise direction: In the negative direction
Metric system : 0.001, 0.01, 0.1 mm (per division)
Inch system : 0.0001, 0.001, 0.01 inch (per division)
- ④ Turn the pulse handle. The axis moves in the positive or negative direction according to the direction in which the pulse handle is turned.

2.5 MANUAL OPERATION (2)

This section describes manual operations carried out in daily production using the manual operation functions explained in 2.4 "MANUAL OPERATION (1)".

2.5.1 Simultaneous 3-axis Handle Feed *

By installing the pulse handle for the individual axes, it is possible to move three axes among the X-, Z-, and C-axis simultaneously. Follow the procedure indicated below.

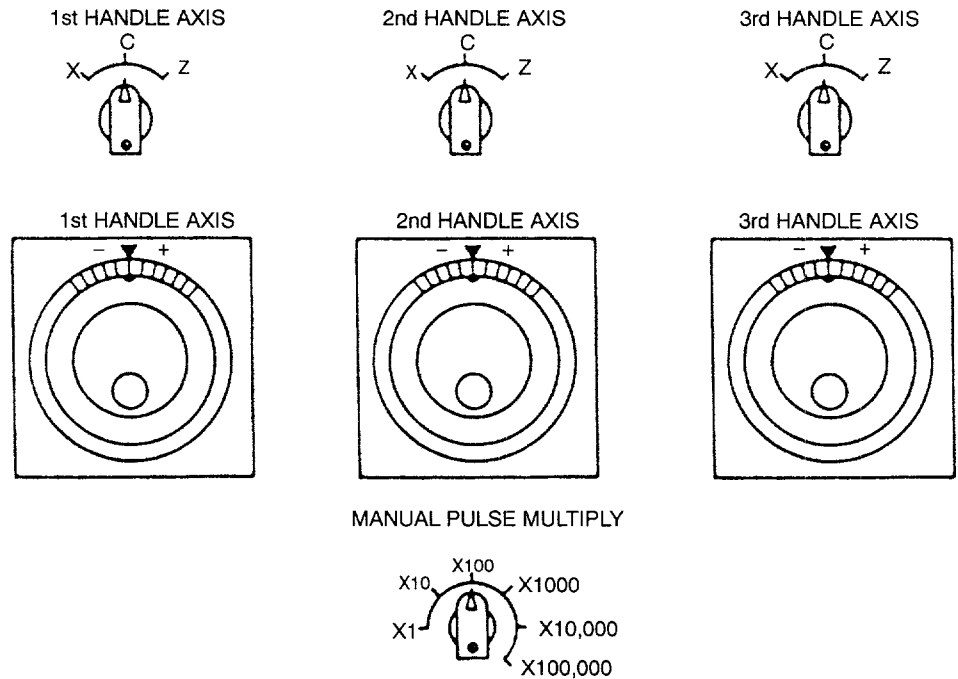

Fig. 2.8 Simultaneous 3-axis Pulse Handle Feed

- ① Select the handle mode by placing the MODE SELECT switch on the machine operation panel in the HANDLE position.
- ② Select the axis feed distance per graduation of the pulse handle with the MANUAL PULSE MULTIPLY switch on the machine operation panel. This switch is used in common for the three pulse handles.
- ③ Turn the pulse handle. The selected axis is moved in the positive or negative direction according to the handle turning direction.

2.5.2 Manual Reference Point Return

Axes can be returned to the reference point in manual operation. Follow the procedure indicated below.

- ① Select the rapid or jog mode by placing the MODE SELECT switch on the machine operation panel in the RAPID or JOG position.
- ② Move an axis manually (manual rapid traverse or jog feed) to a position away from the reference point (within the reference point return enabled area). When an axis is located in range A in Fig. 2.9, reference point return can be executed correctly.
- ③ Turn ON the REFERENCE POINT RETURN switch.
- ④ Keep the JOG switch pressed corresponding to the axis to be returned to the reference point and in the return direction. When the JOG switch is held pressed, the corresponding axis starts moving in the same manner as ordinary manual axis feed operation. When the axis reaches the deceleration point, feedrate is decelerated to a low feedrate and the axis stops automatically at the reference point.
- ⑤ Upon completion of the reference point return, the REFERENCE POINT lamp of that axis lights.

2

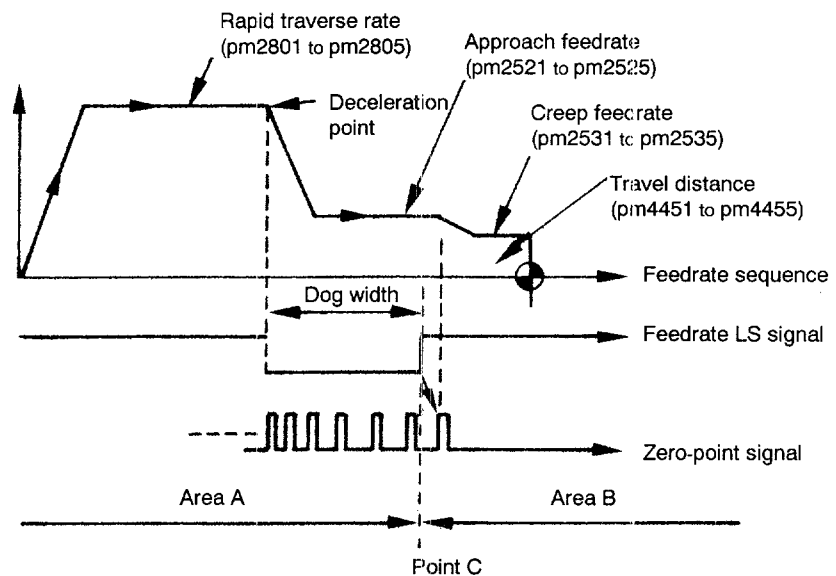

Fig. 2.9 Manual Reference Point Return



◆ Reference Point

A specific position in the machine coordinate system. It is also called the machine zero point or the machine reference point.



2

-
1. Once the reference point return is completed, point C indicated in Fig. 2.9 is stored to the NC. Therefore, if reference point return is attempted while an axis is in area B, an error occurs. In this case, the axis should first be returned to area A and then the reference point return should be executed.
 2. The axis for which reference point return has been completed can be moved in the reference point return direction manually only if the reference point return switch is turned OFF.
 3. If commands have been read to the buffer area during automatic operation, manual reference point return must not be executed. If manual return operation is executed, the data in the buffer area is cleared.
-

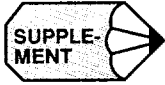

1. Immediately after the power is turned ON, the axes start manual or automatic reference point return operation independent of the present axis position. However, reference point return cannot be executed correctly if the axis is located in area B. In this case, the axis must be returned to area A before executing reference point return.
2. If the MODE SELECT switch setting is changed while an axis is moving automatically to the reference point, an alarm (alarm 2141 to 2145 reference point return interruption error) occurs.
3. Reference point return cannot be executed when the MACHINE LOCK switch is ON.
4. With a rotary axis, it is possible to execute automatic reference point return as with a linear axis. With a rotary axis, if it has been moved by more than $\pm 360.000^\circ$ from the reference point established first, reference point return is executed to the closest reference point in the preset direction of reference point return.

The illustration below shows how the reference point return is executed from points A and B. (The reference point return direction is determined by the setting for pm4002 D3 and D4.)

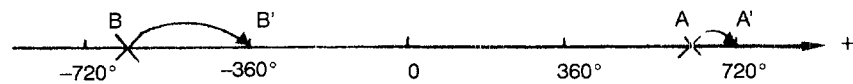

5. Once the reference point return is completed, second and later reference point return is executed at a high-speed mode. This is called "high-speed reference point return". However, if the setting is so made to execute the reference point return at a low speed (pm4003 D6 = 1), second and later reference point return is executed at a low speed.

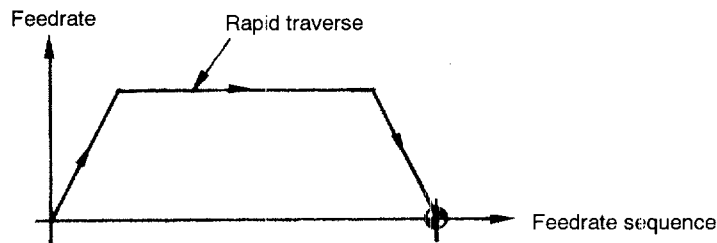

2.5.3 Manual Reference Point Return to the Second Reference Point *

The axes are automatically positioned at the second reference point. This operation allows positioning at the second reference point independent of the present axis position, whether it is in the negative side or positive side from the second reference position. Follow the procedure indicated below.

- ① Select the jog or rapid mode by placing the MODE SELECT switch in the JOG or RAPID position.
- ② Turn ON the ZRN2 (second zero point return request) switch on the machine operation panel.
- ③ Keep the JOG switch corresponding to the axis and direction of reference point return. The corresponding axis is positioned at the second zero point at the jog feedrate or rapid traverse rate according to the selected mode.
 - If the ZRN2 switch is turned OFF while an axis is moving to the second reference point, the axis stops moving. To restart the second reference point return operation, turn ON the ZRN2 switch and turn OFF the JOG switch having been pressed once, then press it once again.
 - If the JOG switch is pressed again to be turned OFF while the X-axis is moving to the second zero point, the axis stops moving. In this case, press the JOG switch again to turn it ON, and the X-axis restarts moving to the second zero point. With the Y- and Z-axis, this is also applied.



1. If the JOG switches of [+] and [-] are pressed at the same time, the corresponding axis stops moving since this operation is assumed to have turned OFF the JOG switch.
2. It is not allowed to use the first zero point return mode and the second reference point return mode at the same time. If both input signals are ON at the same time, both of the modes are invalid and neither jog nor rapid feed is executed. This feature is provided to ensure safety.
3. If the NC is in either the machine lock state (including the machine lock for individual axes) or the Z-axis command disregard state, the second zero point return operation cannot be executed. When a JOG switch is pressed under such state, normal jog operation is performed.
4. With the axis for which second zero point return has been completed, manual axis move operation is allowed only after the ZRN2 (second reference point return) switch is turned OFF.

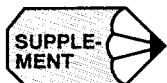

1. If the second zero point return input signal is turned ON in the state that the first zero point return has not been completed, the input is invalid and the second reference point return mode cannot be set.
2. In the second reference point return mode, input from the JOG switch [-X] ([-Z], [-C]) is valid. If the mode is changed, the ZRN2 switch is assumed to have been turned OFF.

2.5.4 1-line MDI

During the execution of manual operation, it is possible to execute one block of a part program by directly entering it to the CRT screen. For this type of operation, a maximum of 40 characters can be written and the function codes that are allowed are M, S, T, F, and E codes. However, M00, M01, M02, M30, M90 to M99, and M190 to M199 cannot be specified. An offset command with a T command is also disregarded. With the system that carries out set-up by using a T command, a T command must not be specified for this 1-line MDI operation. Follow the procedure indicated below.

- ① Select the manual mode with the MODE SELECT switch on the machine operation panel. 1-line MDI operation is not possible in the automatic or edit mode.
- ② Enter the program from the operation panel and press the [EOB] (carrier return) key.
- ③ Press the CYCLE START switch on the machine operation panel, and the entered program is executed. When the execution of the program is completed, the program displayed in the key entry display area is cleared.
 - If the mode is changed while the program is executed (waiting for FIN), the FIN is not returned forcibly and the NC remains in the state waiting for the input of FIN.

2.6 AUTOMATIC OPERATION (1)

This section describes basic information necessary for performing automatic operation.

CAUTION

- Before carrying out cutting operation with a new program, confirm safety by performing single block operation and dry run operation.
If this check operation is not performed, unexpected operation may be performed due to mis-setting of the amount of offset, leading to tool damage due to interference, and resulting accidents involving injuries to personnel.
- Strictly observe the cautions in the user's manual when using programming functions.
Ignoring these cautions could lead to accidents involving injuries to personnel and malfunctions.

2

2.6.1 Preparation of Automatic Operation

After turning ON the power, the axes must be positioned at the start point defined in a program before starting automatic operation. Set the coordinate system to be used for machining either manually or by specifying appropriate commands in a program. Several examples are given below to explain how the the coordinate system should be set. For details, refer to the manuals published by the machine tool builder.

(1) Setting the Coordinate System

The origin of the coordinate system to be used for executing the commands should be set.

(a) When G50 is not specified in the program

The coordinate system for which the origin is set at other than the reference point for the program not containing the coordinate system setting command (G50) is called a coordinate system for machining. The procedure for setting a coordinate system for machining is indicated below.

- ① Return the axes to the reference point by following the manual reference point return procedure (see 2.4.2.).
- ② Select the MDI mode by placing the MODE SELECT switch on the machine operation panel in the MDI position.

- ③ Write the program for setting the coordinate system.

For example,

```
G50 X ··· Z ··· * C ··· ;
```

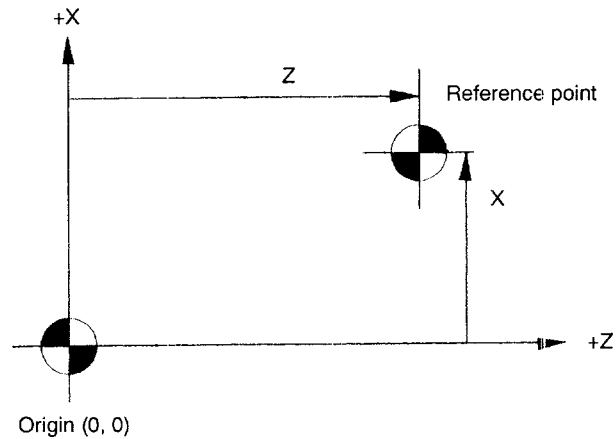

Fig. 2.10 Coordinate System for Machining

- ④ Execute the program by pressing the CYCLE START switch on the machine operation panel.

- (b) When G50 is specified in the program

Return the axes to the reference point by manual reference point return operation.

Example of Programming

```
EOR;
N1 G50X ··· Z ··· * C ··· ;
```

- (c) When G28 (automatic reference point return) and G92 are specified in the program

Move the axes manually to a position (in the area where reference point return operation is allowed) away from the reference point.

Example of Programming

```
EOR;
N1 G28 ··· Z ··· * C ··· ;
N2 G50X ··· Z ··· * C ··· ;
```

(2) Start Lock

Keep the machine in the start lock state until it is confirmed that machine operation is permitted. Follow the procedure indicated below.

- ① Before starting machine operation, turn the START LOCK switch on the machine operation panel ON.
- ② After safety is confirmed, turn the START LOCK switch OFF.

2.6.2 Memory Operation

Memory mode operation is used to carry out automatic operation by using programs stored in the NC memory. Follow the procedure indicated below.

- ① Make sure that the alarm indicating lamp on the machine operation panel is not lit. Note that with some types of machines, the alarm indicating lamp is not provided on the machine operation panel. If the alarm indication is given, locate the cause by referring to 9.1.4, “Cause of Alarm and Corrective Action” and take appropriate measures to clear it.
- ② Check the tool offset amounts and correct them if necessary, then position the axes at the start point. For details of tool offset, refer to 5.3, “TOOL DATA CONTROL JOB”.
- ③ Carry out necessary settings with the switches on the machine operation panel.
 - Select the memory mode by placing the MODE SELECT switch in the MEM position.
 - Set the SINGLE-BLOCK switch ON or OFF. To execute the program block-by-block, set it ON.
 - Set the rapid traverse rate with the RAPID TRAVERSE RATE OVERRIDE switch.
 - Set the MANUAL ABSOLUTE switch ON or OFF. Set the switch ON to return the tool by manual operation intervention to the previously located position.
 - Set the OPTIONAL BLOCK SKIP switch ON or OFF. Set the switch ON to disregard the blocks that include the “/” (slash) code.
 - Set the OPTIONAL STOP switch ON or OFF. To execute the optional stop function (M01), set the switch ON.
 - Set the DRY RUN switch ON or OFF. Set the switch ON when checking the program.

- With the FEEDRATE OVERRIDE and JOG FEEDRATE switches, set the feed-rate.
- ④ Press the [RESET] key on the NC operation panel. The program is rewound to the beginning and “LSK” (label skip) message is displayed on the CRT screen.
- ⑤ Press the CYCLE START switch on the machine operation panel to start automatic operation.
- ⑥ To suspend operation temporarily, press the FEED HOLD switch on the machine operation panel.

2



1. In case of emergency, press the EMERGENCY STOP button on the machine operation panel to stop the machine immediately.
2. It is possible to start a program half way in the memory mode operation. Locate the cursor at the required start block by using the address search operation, and press the CYCLE START switch. For this operation, however, the modal G codes must be set before starting the program.
3. In the memory mode, address search must always be executed by specifying “address + numeral”.

2.6.3 MDI Operation

Automatic operation is possible by inputting a program in the MDI mode. Follow the procedure indicated below.

- ① Select the MDI mode with the MODE SELECT switch on the machine operation panel.
- ② Enter the block of commands from the keyboard. For details of program entry operation in the MDI mode, refer to 6.2, “MDI OPERATION JOB”.
- ③ Press the CYCLE START switch on the machine operation panel and the execution of the entered program is started.

2.6.4 Feed Hold

The feed hold function suspends automatic operation temporarily. Follow the procedure indicated below.

2

- ① When the FEED HOLD switch on the machine operation panel is pressed while an axis is moving, it stops after deceleration. The CYCLE START lamp on the machine operation panel goes OFF and the FEED HOLD lamp lights.
- ② After the completion of axis movement, the indicating lamp goes OFF.

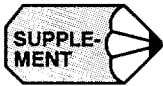

-
1. If the execution of a drilling canned cycle is stopped halfway due to the single-block function, the FEED HOLD lamp automatically goes ON to indicate that the operation is suspended during the execution of a drilling canned cycle.
 2. The setting of the FEED HOLD switch is disregarded while a tapping cycle is executed in the G84 mode.
 3. If the FEED HOLD switch is turned ON while M, S, or T function not associated with axis movements is executed, the function is continuously executed to be completed although the FEED HOLD lamp lights immediately. After the completion of the function, the FEED HOLD lamp goes OFF and operation stops.
-

2.6.5 Override

The following gives a general description of the override function. For details of override, refer to the manuals published by the machine tool builder.

(1) Feedrate Override

In the automatic mode (TAPE, MEM, MDI), feedrate specified by an F code can be overridden in 21 steps in the range from 0 to 200% in increments of 10%, using the FEEDRATE OVERRIDE switch on the machine operation panel. During the execution of a tapping cycle (G74, G84), the setting is disregarded and the tapping cycle is executed in the feedrate specified by the program. If the OVERRIDE CANCEL switch is ON, the setting of the FEEDRATE OVERRIDE switch is disregarded and the axes are moved at the feedrate specified by the F (or E) codes in a program.

Table 2.1 Feedrate Override Steps

STEP	%	STEP	%
0	0	11	110
1	10	12	120
2	20	13	130
3	30	14	140
4	40	15	150
5	50	16	160
6	60	17	170
7	70	18	180
8	80	19	190
9	90	20	200
10	100	-	-

2



Optionally, feedrate override range can be expanded to 0 to 540% (32 steps). In this case, override increments are 10% in the range from 0 to 200%, 20% in the range from 220 to 300%, and 40% in the range from 340 to 540%.

(2) Rapid Traverse Override

For the G00 mode operation in automatic mode and for the rapid mode operation in manual mode, the switch can be installed to adjust rapid traverse rate in 4 steps (100%, 50%, 25%, F_0) in the range from 0 to 100%, using the RAPID TRAVERSE OVERRIDE switch on the machine operation panel. For F_0 , actual override value is set for parameter (pm2447).

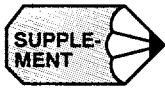

Optionally, override setting is possible in 6 steps as 100%, 50%, 25%, F_0 , F_1 , and F_2 . The feedrates called by the selection of F_1 and F_2 are set for parameters (pm2448 and pm2449). For details, refer to the manuals published by the machine tool builder.

2.7 AUTOMATIC OPERATION (2)

This section describes the switches used for automatic operation.

2.7.1 Optional Stop

The OPTIONAL STOP switch is used to select whether or not the M01 (optional stop) command should be executed in the automatic mode (TAPE, MEM, MDI).

(1) OPTIONAL STOP Switch ON

When the OPTIONAL STOP switch is ON, the machine stops operating with the CYCLE START lamp on the machine operation panel lit after the execution of the block that includes M01. The CYCLE START lamp goes OFF if the FIN signal is returned. The operation restarts when the CYCLE START switch is pressed.

(2) OPTIONAL STOP Switch OFF

The M01 command is disregarded. If the OPTIONAL STOP switch setting is changed during the execution of an automatic operation, it is disregarded for the block presently executed. The new setting becomes valid from the block which is read after the switch setting has been changed.

2.7.2 Optional Block Skip

The OPTIONAL BLOCK SKIP switch is used to set whether or not the data in the block which includes the “/” (slash) code should be disregarded in automatic operation. Note that if the switch setting is changed during operation, the new setting is not valid for the blocks having been read to buffer area.

(1) OPTIONAL BLOCK SKIP Switch ON

When the OPTIONAL BLOCK SKIP switch is ON, the commands specified after the “/” (slash) code are disregarded (up to the end of the block). For the blocks in which the “/” code is specified, the commands specified preceding the “/” code are executed.

(2) OPTIONAL BLOCK SKIP Switch OFF

The blocks which include the “/” (slash) code are executed. If the OPTIONAL BLOCK SKIP switch setting is changed during the execution of an automatic operation, it is disregarded for the block presently executed and also for the blocks having been read to the buffer area. The new setting becomes valid from the block which is read after the switch setting has been changed.

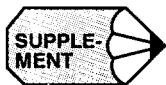

1. Specification of “/” is equivalent to “/1”.
2. When the optional block skip B function is selected, the switches are provided corresponding to “/2” to “/9” individually and by using these switches, it is possible to turn ON and OFF the block skip function for the individual designation of “/2” to “/9”.

2

2.7.3 Dry Run

When automatic mode operation (TAPE, MEM, MDI) is executed with the DRY RUN switch set ON, feedrates specified in a program are disregarded and axis move commands are executed at the feedrate set with the JOG FEEDRATE switch. Since the F code specified in a program is displayed during the execution of a program, the program can be checked efficiently by using this function.

Feedrate to be used in positioning (G00) can be selected from the rapid traverse rate or jog feedrate according to the setting for parameter pm2000 D0 as indicated in Table 2.2.

Table 2.2 Rapid Traverse in Dry Run

Parameter pm2000 D0	G00 in Dry Run
“0”	Rapid traverse rate
“1”	Jog feedrate set with JOG FEEDRATE switch



1. When the setting of the DRY RUN switch is changed during automatic operation, the new setting becomes valid immediately. However, if it is changed while axis movement is controlled in the “mm/rev” mode* or during the execution of a tapping cycle, the new setting becomes valid after the completion of the presently executed block.
2. In the dry run mode, the setting of the RAPID TRAVERSE RATE OVERRIDE switch is valid for rapid traverse operation.

2.7.4 Machine Lock

The MACHINE LOCK switch allows the program to be executed in the following manner – to operate the machine with the present position data fixed, or to execute the program to update the present position data without actually operating the machine. The switch can be operated only while the operation is stopped in the block stop or feed hold state.

2

(1) MACHINE LOCK Switch ON

As the program commands are executed manually or automatically, the position data are updated according to the execution of the commands while the machine is not actually operated. With this setting, the M, S, and T functions are executed normally. This are used for manually presetting the display or for checking the tape. Note that the reference point return operation is not executed if the switch is placed in the MACHINE LOCK position.

(2) MACHINE LOCK Switch OFF

Select this position for normal manual or automatic operation. Both the machine and the position data are operated and updated according to the execution of the commands in the program.

2.7.5 Auxiliary Function Lock

The AUX FUNCTION LOCK switch on the machine operation panel is used to check the NC tape in combination with the MACHINE LOCK function. When the switch is ON, the M, S, and T function commands are disregarded. When the switch is turned ON during automatic operation, the function becomes valid from the block next to the presently executed block.



1. The M00, M01, M02, and M03 codes are processed normally.
2. Both the decode signal and BCD code are output. However, BCD code is not output with M90 to M99 (internally processed M codes); BCD code is not output inherently with these M codes.
3. The AUX FUNCTION LOCK switch setting is invalid for the S5-digit commands.

2.7.6 Feed Hold in Thread Cutting *

When the FEED HOLD button on the machine operation panel is pressed during the execution of a thread cutting canned cycle, with this option selected, chamfering is executed immediately and the thread cutting tool returns to the start point A. If parameter setting is “pm4011 D2 = 1”, the cutting tool stops at the end point of chamfering (point B). In this case, the cutting tool returns to the start point A when the CYCLE START button is pressed while the cutting tool stays at point B.

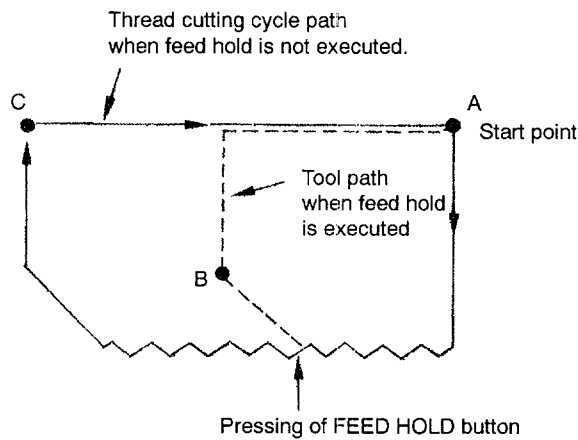

Fig. 2.11 Feed Hold in Thread Cutting Cycle

Without this option, pressing of the FEED HOLD button during thread cutting canned cycle cannot interrupt the cycle. Even when the FEED HOLD button is pressed, the cycle is continued and it stops when the thread cutting tool reaches point C where the retraction movement is finished.

2.8 OPERATION INTERVENTION DURING AUTOMATIC OPERATION

This section describes the procedure used for manual and MDI operation intervention during automatic operation.

CAUTION

- Do not restart automatic operation after stopping automatic operation and then performing “tool selection” in manual operation or “1 line MDI” operation. The reason for this is that the “tool selection” operation may cause the coordinate system to be changed, leading to unexpected operation if automatic operation were restarted. This could cause tool damage due to interference, and resulting accidents involving injuries to personnel.
Reset the NC after any manual intervention.
- After stopping automatic operation and performing a manual intervention, do not restart automatic operation without resetting first. If automatic operation is started with the “mirror image” or “manual absolute” function in effect, unexpected operation may be performed. This could cause tool damage due to interference, and resulting accidents involving injuries to personnel.
Reset the NC after any manual intervention.

2

2.8.1 Manual Operation Intervention during Automatic Operation

To carry out a manual operation during automatic operation, follow the steps indicated below.

- ① Interrupt the operation by using the FEED HOLD or SINGLE-BLOCK switch on the machine operation panel.
- ② Record the position where the operation has been interrupted after displaying the present position data by pressing the [EXTERN] (F3) key of the POS. job at the COMN screen.
- ③ Select the manual mode (RAPID, JOG, STEP or HANDLE) with the MODE SELECT switch on the machine operation panel.
- ④ Return the axes to the position where manual operation (see 2.3 “MANUAL OPERATION (1)”.) has been started (the position recorded in step ②).
- ⑤ Return the MODE SELECT switch to the operation mode (MEM or MDI) position selected before manual operation intervention.
- ⑥ Press the CYCLE START switch on the machine operation panel to restart the interrupted automatic operation.

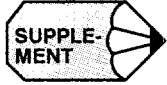

1. If the operation mode is changed from automatic to manual without stopping the operation, the axes are decelerated and stopped immediately. When the operation mode is changed from one automatic mode to another automatic mode, operation stops at the block end.
2. If automatic operation is restarted without returning the axes to the previously located position after manual operation intervention, how the tool paths to be generated after the restart of automatic operation differs depending on the setting of the MANUAL ABSOLUTE switch on the machine operation panel. For details of the switch, refer to 2.8.4, "Manual Absolute".
3. In the manual mode, 1-line MDI operation is possible. For details of the operation, refer to 2.5.4, "1-line MDI".

2.8.2 MDI Operation Intervention during Automatic Operation

To carry out an MDI operation during automatic operation, follow the steps indicated below.

- ① Interrupt the automatic operation by turning the SINGLE-BLOCK switch on the machine operation panel ON. The machine stops after the completion of the block being executed when the switch is turned ON. In this case, several blocks of commands might have been read into the buffer area.
- ② Place the MODE SELECT switch on the machine operation panel in the MDI position.
- ③ Enter the necessary commands.
- ④ Press the CYCLE START switch to execute the entered commands.
- ⑤ Return the MODE SELECT switch to the mode previously selected (TAPE or MEM).
- ⑥ Turn OFF the SINGLE-BLOCK switch.
- ⑦ Press the CYCLE START switch to restart the interrupted automatic operation.

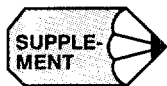

Do not attempt MDI operation intervention in a canned cycle mode (G73, G74, G76, G77, G81 to G89) or during reference point return. Interrupted canned cycle or reference point return could not be completed correctly.

2.8.3 Automatic Handle Mode Offset *

During automatic operation (TAPE, MDI, MEM), distance of axis shift carried out by using the pulse handle can be added by this function. This function allows compensation for errors in mounting workpieces, etc. Follow the procedure indicated below.

- ① Turn ON the AUTO MODE HANDLE OFFSET switch on the machine operation panel.
- ② Select the axis to be moved with the HANDLE AXIS switch on the machine operation panel. If the simultaneous 3-axis control by using the pulse handles is selected optionally, simultaneous 3-axis operation is allowed.
- ③ Select the axis feed distance per graduation of the pulse handle by placing the MANUAL PULSE MULTIPLY switch on the machine operation panel at an appropriate position. By this switch, it is possible to select 1, 10, or 100 pulses per graduation of the manual pulse generator.
- ④ When the pulse handle is turned during the execution of automatic operation, movement of the axis which is selected in step ② above is added to the axis move distance specified in the program. When the pulse handle is turned in the clockwise direction, the selected axis moves in the positive direction and when it is turned in the counterclockwise direction, the axis moves in the negative direction.
- ⑤ Restart the automatic operation after turning the AUTO MODE HANDLE OFFSET switch OFF. Succeeding operation is executed with the axis shifted by the pulse handle operation. When the coordinate system set-up command (G92, etc.) is executed after that, the shift amount is not included but the coordinate system is set according to the specified values.

2

Table 2.3 Setting Valid/Invalid for AUTO MODE HANDLE OFFSET

Axis	Parameter		Valid/Invalid
	No.	Setting	
1st-axis (X-axis)	pm2002 D0	1 0	Valid Invalid
2nd-axis (Z-axis)	pm2002 D1	1 0	Valid Invalid
3rd-axis (C-axis)	pm2002 D2	1 0	Valid Invalid

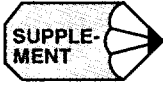

1. If the NC is in an alarm state or the interlock input (see 1.2.4.) is ON, it is not possible to move an axis by using the automatic mode handle offset function.
2. With parameter pm2003 D1, the condition necessary for moving an axis by using the automatic mode handle offset function can be set.

pm2003 D1 = 0	Enabled during both rapid traverse and interpolation operation
pm2003 D1 = 1	Enabled only during interpolation operation

3. The manual absolute function cannot be used in this function.

2.8.4 Manual Absolute

If a cutting tool is moved manually by interrupting automatic operation, how the manually moved distance should be treated when restarting automatic operation can be determined by the setting of the MANUAL ABSOLUTE switch on the machine operation panel.

(1) MANUAL ABSOLUTE Switch ON

After the intervention of manual operation, the program coordinate system is not changed. Subsequently, the remaining commands in the interrupted block are executed by shifting from the programmed path when automatic operation is restarted. When the block appearing next to the operation restarted block is the circular interpolation block (G02, G03), circular interpolation is executed with the paths shifted from the programmed paths. When the G00 or G01 mode commands are given, the shift distance is canceled, and the paths return to the programmed paths.

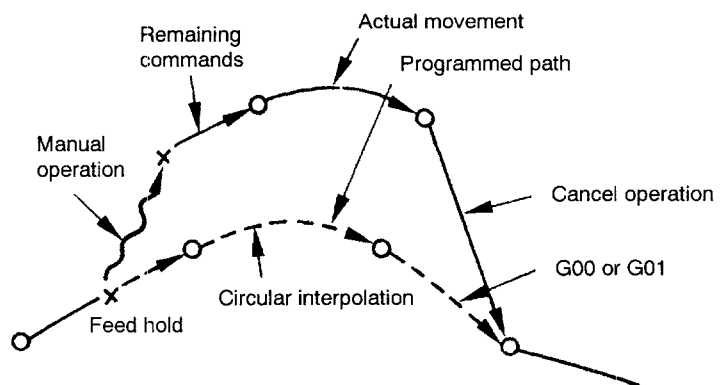

Fig. 2.12 Operation with MANUAL ABSOLUTE Switch ON

(2) MANUAL ABSOLUTE Switch OFF

If manual operation is executed by interrupting automatic operation, the program coordinate system is shifted by the manually shifted distance. Accordingly, when automatic operation is restarted, the program is executed in the shifted coordinate system.

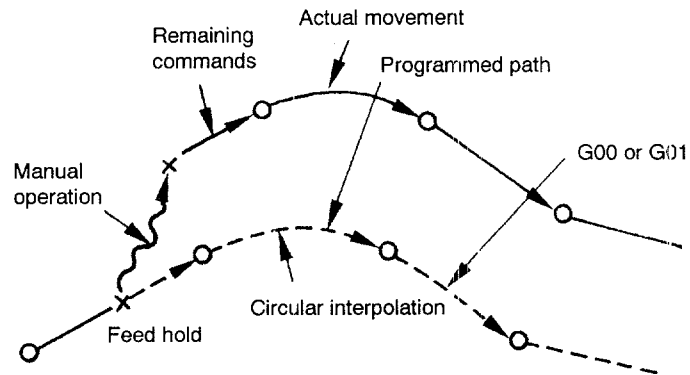

Fig. 2.13 Operation with MANUAL ABSOLUTE Switch OFF

The manually shifted amount is canceled by the following commands or operation in which the commands in the program are changed so that they agree with the present values.

- Manual or automatic reference point return
- Setting the base coordinate system
- Execution of skip (G31)
- Reset operation

2.9 AUTOMATIC OPERATIONS AT ENHANCED LEVEL

In this section, enhanced level functions of YASNAC J300 are described.

2.9.1 Return to the Setup Point

The function executes positioning at a jog feedrate at the position where the coordinate system has been established (setup point). If the SRN input signal is “closed”, axis movement at a jog feedrate stops after the completion of positioning at the setup point. Further jog feed is not possible unless the SRN input signal is “opened”.

2

2.9.2 Return to the Operation Interrupted Point *

The “return to operation interrupted point” function is provided to return the axes to the previously located position where automatic operation has been interrupted to carry out manual operation for measuring the machined dimensions or removing chips.

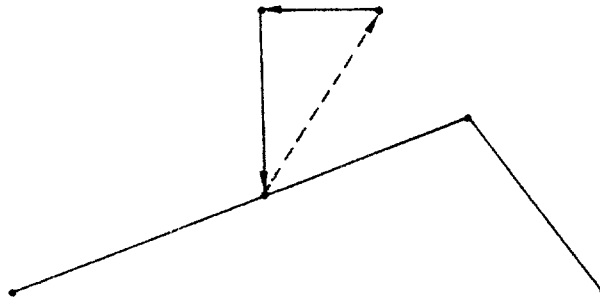

Fig. 2.14 Return to Operation Interrupted Point

The operation procedure is explained below.

- ① Interrupt the automatic operation by pressing the SINGLE-BLOCK or FEED HOLD switch on the machine operation panel.
- ② Select a manual mode by placing the MODE SELECT switch on the machine operation panel in the JOG, RAPID, HANDLE, or STEP position.
- ③ Move an axis in the manual mode to retract the cutting tool appropriately.
- ④ Carry out required operation such as measuring the workpiece, removal of chips, etc.
- ⑤ Turn ON the INTERRUPTION POINT RETURN switch on the machine operation panel.

- ⑥ Press the MANUAL PULSE MULTIPLY switch on the machine operation panel corresponding to the direction to the machining interrupted point (the point where the operation mode has been changed from automatic to manual). The axis moves to the machining interrupted point at the selected feedrate and it stops moving when it reaches the machining interrupted point.
- ⑦ Turn OFF the INTERRUPTION POINT RETURN switch on the machine operation panel.
- ⑧ Return the operation mode to an automatic mode and press the CYCLE START switch on the machine operation panel. The automatic operation restarts.

2

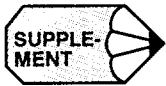

1. If the axes are positioned on the machining interrupted point, turn OFF the INTERRUPTION POINT RETURN switch. Otherwise, jog feed of such axes is not possible.
2. If the NC is reset after changing the operation mode from automatic to manual, the present position is taken as the machining interrupted point. This means that the axes are positioned on the machining interrupted point and, subsequently, jog feed operation is not allowed unless the INTERRUPTION POINT RETURN switch is turned OFF.
3. If automatic operation is interrupted by manual operation for a second time after the automatic operation was once interrupted by manual operation and then the automatic operation was recovered, the point where the operation mode was last changed from automatic to manual is taken as the machining interrupted point.
4. If the REFERENCE POINT RETURN switch or the second reference point return switch is ON, the machining interrupted point return operation is not executed but the reference point return or the second reference point return operation is executed.

2.9.3 Saving the Present Position Data

The signal to save the present position data is provided. When the PST input signal is “opened”, the NC saves the present position data to the internal memory at the timing the signal is opened. Then, it executes the following operation using the offset data written in the MDI operation to store the result of operation to the offset data memory.

$$\begin{aligned} &\text{Value to be written into the offset data memory} \\ &= (\text{Value input in the MDI operation}) - (\text{Present position value saved in the NC memory}) \end{aligned}$$

The present position data is cleared and the LED stops blinking by the reset operation (pressing the [RESET] key on the NC operation panel or “opening” the external reset input signal).



The position at which the present position data is read to be saved, position data saving operation, and the operation to calculate the value which is written to the offset data memory could differ depending on the machine tool specifications.

2.9.4 Program Restart *

By using the program restart function, it is possible to restart an interrupted operation in such cases where execution is interrupted due to breakage of a cutting tool or to restart the program continuously from the block where the operation was stopped the previous day. By designating a sequence number of the block, the function allows the program to be restated from the specified block.

2

(1) Operation

- ① Turn ON the PROGRAM RETURN (program restart) switch on the machine operation panel.
- ② After placing the MODE SELECT switch on the machine operation panel in the MEM position.
- ③ Rewind the program to the beginning. For details of this operation, refer to the explanation given in 6.1, “PROGRAM JOB”.
- ④ Press the [RESTART] (f3) function soft-key on the PROGRAM JOB screen of the RUN process. The message requesting the input of the program restart position information is displayed.
- ⑤ The message “ENTER SEQUENCE NUMBER” is displayed. Enter the sequence number and press the [WR] key.
- ⑥ The message “ENTER THE OCCURRENCE NUMBER” is displayed. If the same sequence number appears more than one time, enter the position of the objective sequence number and press the [WR] key. If designation of the position of the objective sequence number is not necessary, press the [WR] key only.
- ⑦ Press the [WR] key again. Sequence number search starts from the present cursor position.
 - During the execution of the search, the message “PREPARING TO RESTART” is displayed on the screen, and, at the same time, the program restart message “PRS” blinks on and off on the screen. The “PRS” is cleared when the positioning of the axes at the restart position is completed.
 - Upon completion of the search, the program restart information is displayed on the screen.
- ⑧ If the searched sequence number is the objective block, turn OFF the PROGRAM RETURN switch. If it is not the objective block, execute the program restart request again.

- ⑨ If there are M, S, and/or T codes that are necessary for restarting the program, specify one on the program restart information screen. Select the manual mode for this operation.
- ⑩ Enter the necessary M, S, and/or T code and execute it by pressing the CYCLE START switch on the machine operation panel (execution of M, S, and/or T code using the 1-line MDI function).
- ⑪ Return the mode to the memory mode.
- ⑫ Restart the program by pressing the CYCLE START button. When the CYCLE START switch is pressed, the axes move to the operation restart point one by one in the order of X-axis, Z-axis, and C-axis. After that the automatic operation restarts from the block next to the specified sequence number.

(2) Precautions on Operation

- While the “PREPARING TO RESTART” message is displayed, no key operation is accepted except the [RESET] key on the NC operation panel. The G and M code display in the program job of the operation process is not changed.
- After the “PREPARING TO RESTART” message is cleared, it is possible to change the display in the lower half area of the screen to “G/M code information”, “Subprogram nesting information”, or “Program restart information” by pressing the page keys.
- While “PRS” is displayed, it is not allowed to call and edit the program stored in memory.
- The [RESTART] (f3) function soft-key is displayed only when the PROGRAM RETURN switch on the machine operation panel is ON and the NC is in the label skip status.
- The program restart request can be executed without using the PROGRAM RETURN switch.

pm4015 D0 = 0	PROGRAM RETURN switch necessary
pm4015 D0 = 1	PROGRAM RETURN switch not necessary

- When the parameter setting is made so that the PROGRAM RETURN switch is not necessary for the program restart request, the program restart mode ON/OFF is changed by the [RESTART] (f3) soft-key. In this case, operation step ⑧ explained in item (1) above is not necessary.

(3) Remarks on Program Restart and Related Functions

The program restart function establishes various conditions during the execution of sequence number search so that the conditions at the restart will be the same as those when the program was interrupted. However, some program commands require extra care. These are indicated below.

(a) Program restart position

The position for the restart of program is generated in the NC. Therefore, the axes are regarded to move as programmed during the search for the program restart position. If the function is executed in the mode called by the following G codes, the point specified in a program and actual positioning point differ from each other and in such modes, the point specified in the program is regarded as the end point: automatic reference point return (G28), reference point return check (G27), return from reference point (G29), second - fourth reference point return (G30), and machine coordinate system (G53).

(b) Input signal

There are commands that perform different operations depending on the input signals. With one type of signal, the status at the start of search for the program restart is retained, and with another type of signal, they are completely disregarded.

- The signals that retain the status at the start of search:
Mirror image (M95, M94), block delete, machine lock, and F1-digit selection
- The signals that are disregarded:
Feed hold, single-block, auxiliary function lock, skip, program interrupt (M91, M90), and optional stop
- The distance which the axes were moved before cycle start is cancelled disregarding of the ON/OFF status of the manual absolute signal and the commands are executed in the workpiece coordinate system called at the completion of search.

(c) Using a macroprogram

When a macroprogram is used, care must be paid on system variables.

- All interface input/output signals (#1000 - #1031, #1032, #1100 - #1131, and #1132) are processed as “0”. Therefore, correct results cannot be expected.
- Although the clock (#3001, #3002) is read and written normally, the time count at the restart of the program is not guaranteed.
- The control of single-block stop and wait for the completion of auxiliary function (#3003) is disregarded and the specification of control is made invalid.
- The control for feed hold, feedrate override, and exact stop (#3004) is disregarded and the specification of control is made invalid.
- Although the position data (#5000 -) is read normally, the data generated in the NC is used for the operation. For the servo error data (#5101 - #5105), “0” is read.
- Concerning the RS-232C data output 2 (BPRNT, DPRNT), if the program is restarted at the RS-232C open command, an alarm occurs at the execution of the RS-232C output command.

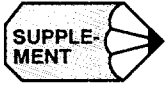

1. When moving the axes to the program restart position by pressing the CYCLE START switch, if interference occurs between the axes and the workpiece or fixture, move the axes to the same position manually.
2. If the CYCLE START switch is pressed while the PROGRAM RETURN switch is ON, the warning message "RESTARTING PROG!" is displayed.
3. After the completion of search for program restart, operation intervention is not allowed in other than manual mode until program restart is executed. If the CYCLE START switch is pressed in the MDI, TAPE or MEM mode, alarm "0292" occurs and the message "IMPOSSIBLE TO START THE COMMAND WHEN RESTARTING PROGRAM" is displayed.
4. If the PROGRAM RETURN switch is ON, it is not possible to move an axis manually. Operation of jog switches and manual pulse generator is disregarded.
5. When requesting the program restart, conditions such as the input signals and tool offset must be the same as those at the interruption of the program. Otherwise, correct restart position and conditions cannot be established. Manual operation that is carried out in the program restart operation is allowed only with the MANUAL ABSOLUTE switch set ON.
6. During the search for program restart, the FEED HOLD switch and the SINGLE-BLOCK switch are disregarded. If the NC is reset during the search, the search is interrupted immediately. If this occurs, it is necessary to request the program to restart once again.
7. This function executes processing on the assumption that the coordinate system has been established correctly before the restart of operation. Therefore, if the restart request is given without executing the reference point return after turning the power ON, alarm "0411" to "0415" occurs and the message "REFERENCE POINT RETURN NOT COMPLETED" is displayed. With the incremental command program, if the coordinate system setting command is not given at the beginning of the program, the restart position cannot be generated correctly.
8. If the sequence number given with the restart request is not found, alarm "0290" occurs and the message "PROGRAM RESTART SEQUENCE NUMBER NOT FOUND" is displayed.
9. Upon completion of the search, if reference point return is executed by changing the mode to manual, or if manual coordinate system setting is executed, alarm "0291" occurs and the alarm message "COORDINATE SYSTEM SHIFTED AFTER PROGRAM RESTART" is displayed.
10. Program restart is impossible for DNC operation, tape operation, and high-speed cutting mode operation.

3

BASICS OF DISPLAY AND WRITING OPERATION

3

Chapter 3 describes the basic terms related to operation and the NC operation panel.

3.1	BASICS OF TERMS RELATED TO OPERATION	3 - 2
3.1.1	Process Screens	3 - 3
3.1.2	Jobs and Functions	3 - 3
3.1.3	YASNAC J300L Function Structure	3 - 4
3.2	NC OPERATION PANEL	3 - 8
3.2.1	Keys and Display Screen on NC Operation Panel	3 - 8
3.2.2	Normal Display on CRT Screen	3 - 15
3.2.3	Pop-up Menu	3 - 20
3.2.4	Key Buffer Edit Function	3 - 21
3.2.5	Buzzer Function	3 - 22

3.1 BASICS OF TERMS RELATED TO OPERATION

This section describes the functions of the keys on the operation panel and guide messages displayed on the screen for each of the operation steps according to the actual operation flow.

3

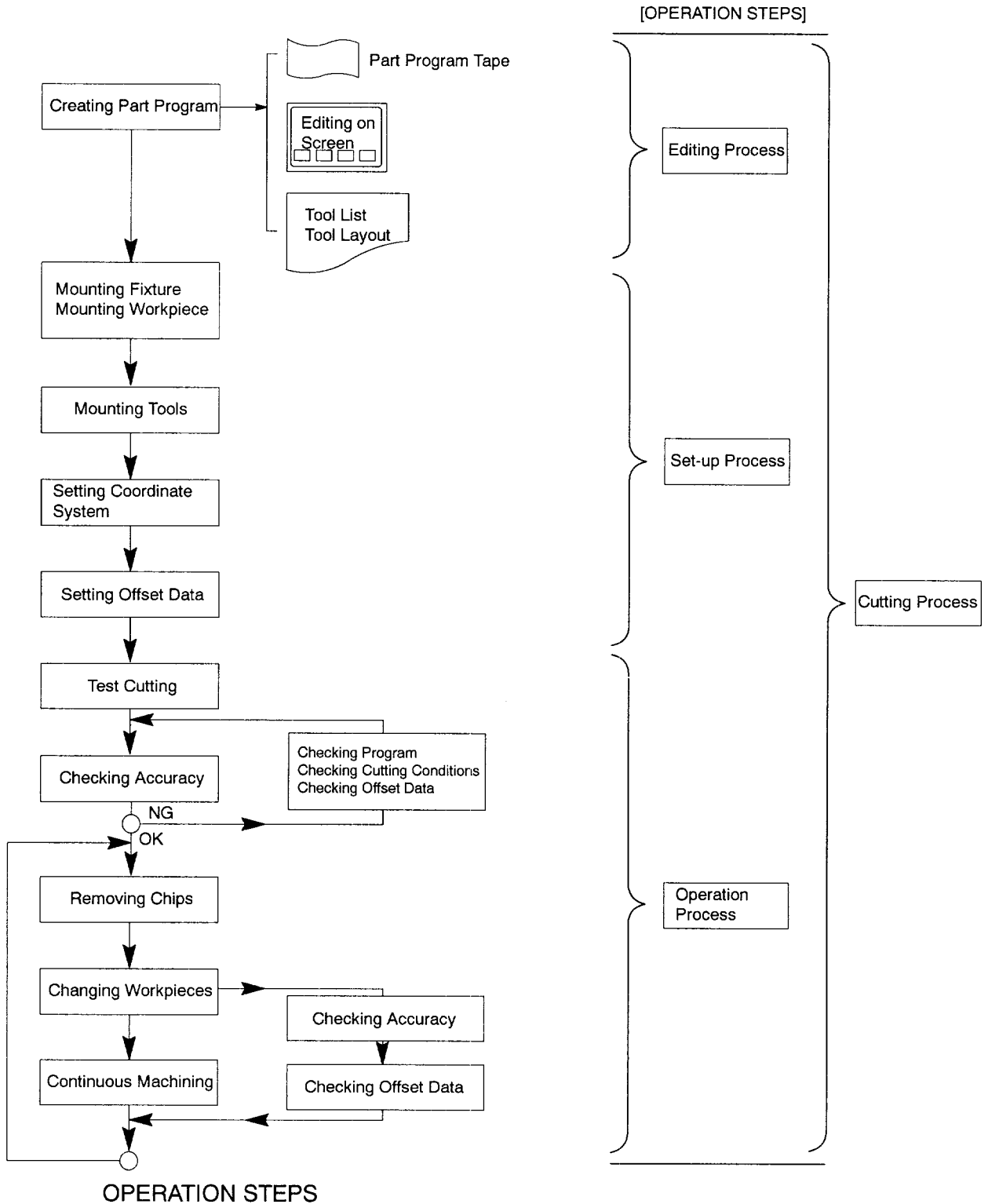

3.1.1 Process Screens

YASNAC J300 provides a variety of display screens and these display screens are largely classified into six blocks according to the processes: edit, set-up, operation (run), maintenance, common, and AUX1.

Process screens directly related to cutting	Edit process screen, set-up process screen, run process screen, AUX1 screen
Process screen related to NC maintenance	Maintenance process screen
Process screen used in common for four cutting related processes	Common process screen

3

At each screen, keys used to control the display are arranged on the NC operation panel (four cutting process keys, maintenance process key, and common process key). By using these keys, the required process screen can be quickly displayed for each machining process.

3.1.2 Jobs and Functions

Each process consists of jobs and each job has functions. One process has a maximum of five jobs, and for each of the jobs there are no restrictions in the number of functions. After selecting a process, the jobs and functions are selected by using soft-keys. Tree structure of the process, jobs, and functions is indicated in Fig. 3.1.

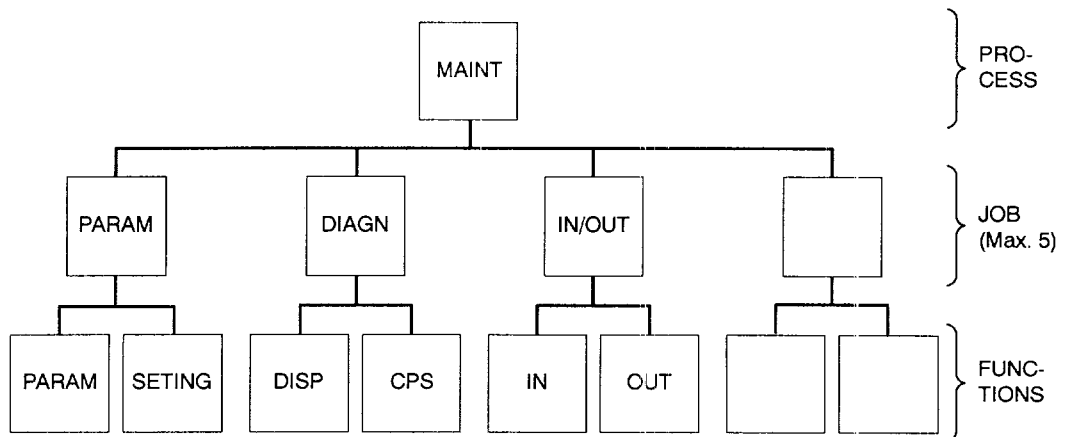
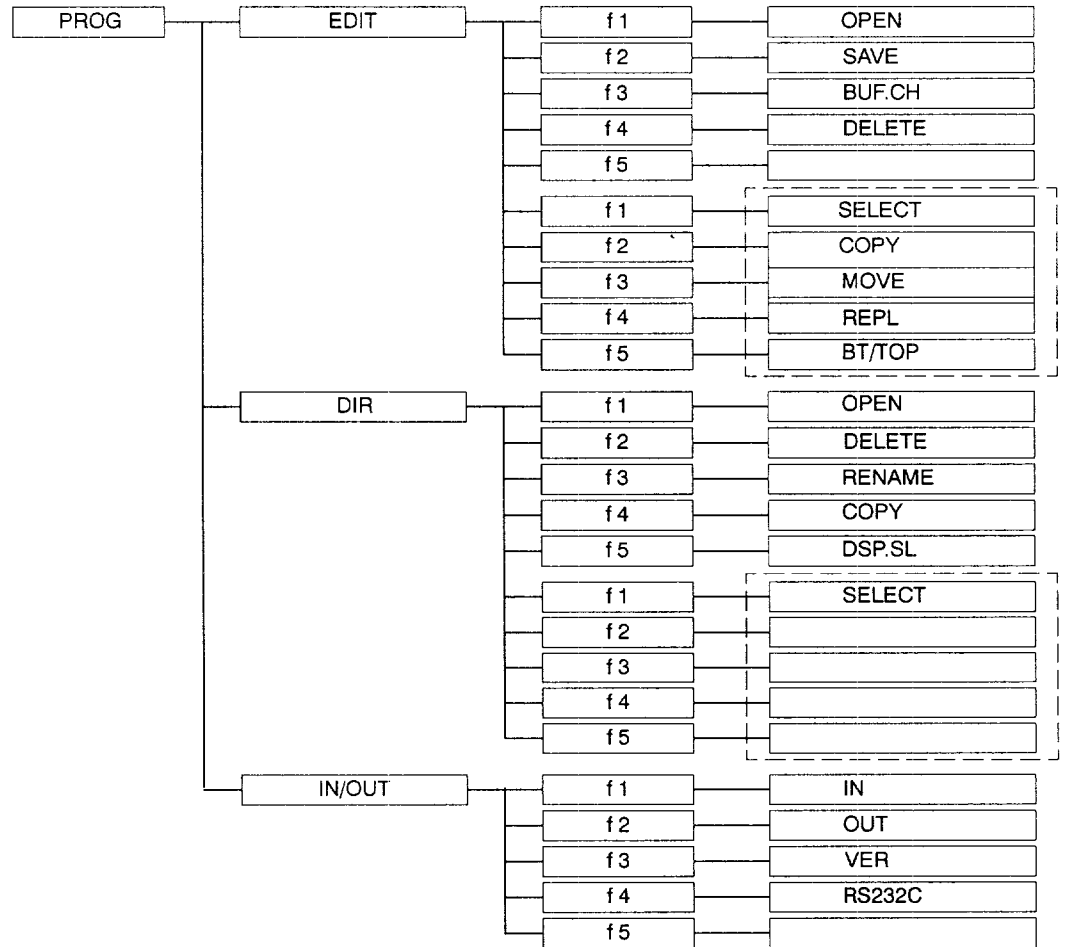

Fig. 3.1 Example of Structure

3.1.3 YASNAC J300L Function Structure

The structure of processes, jobs, and functions is indicated below.



3

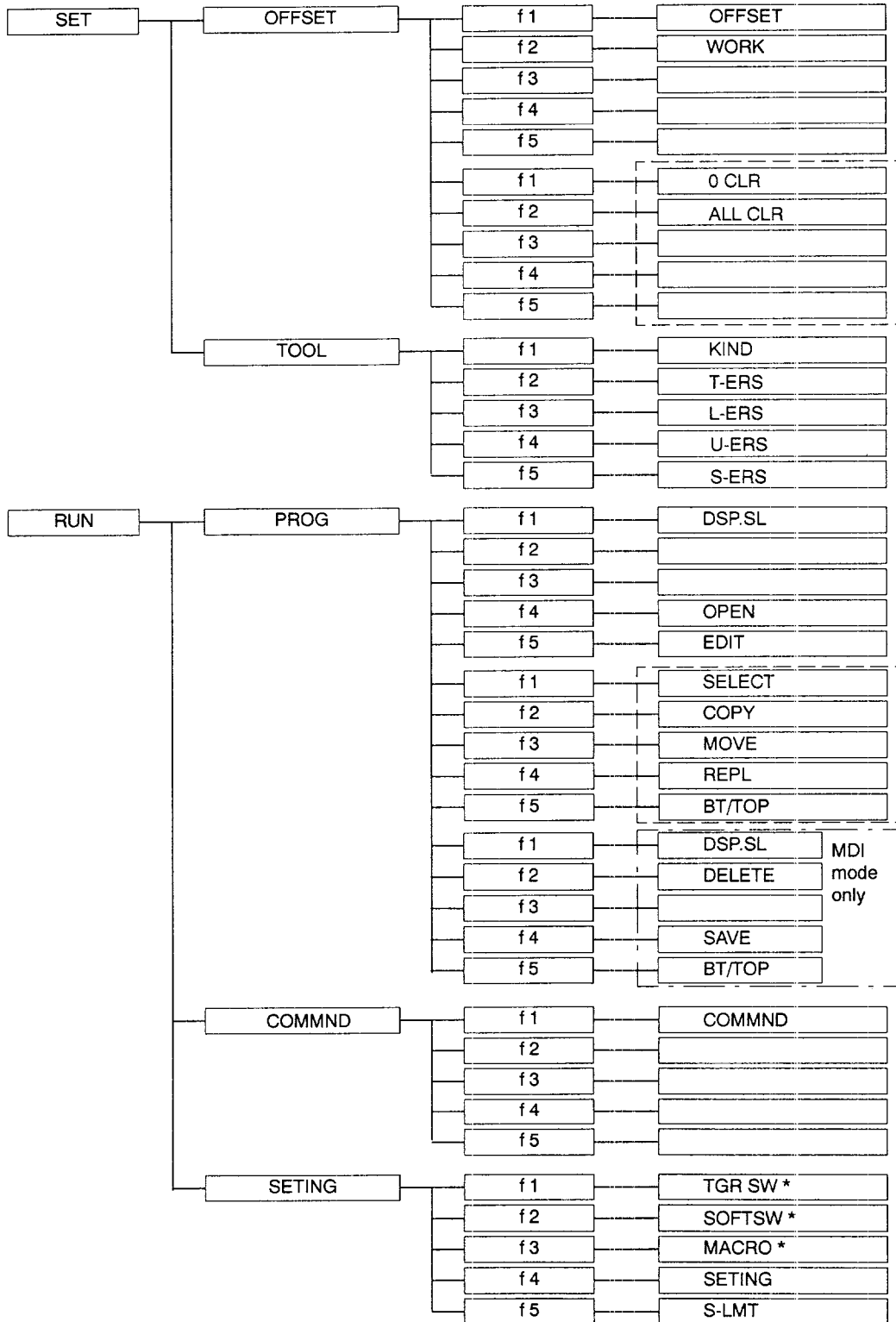

3

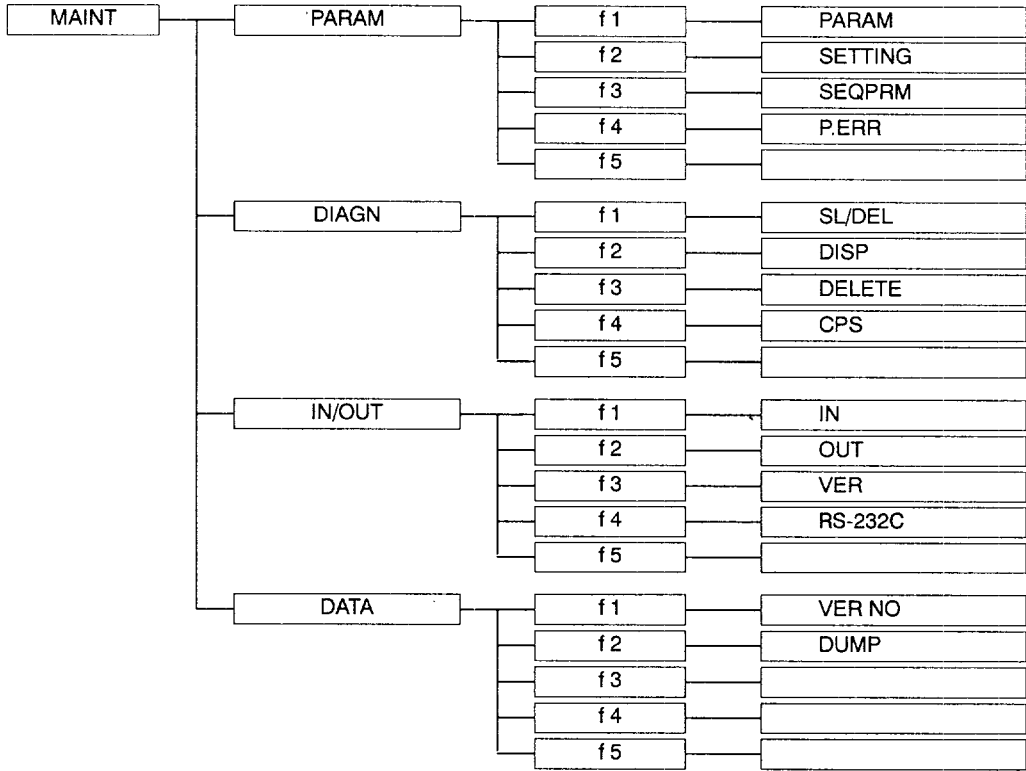

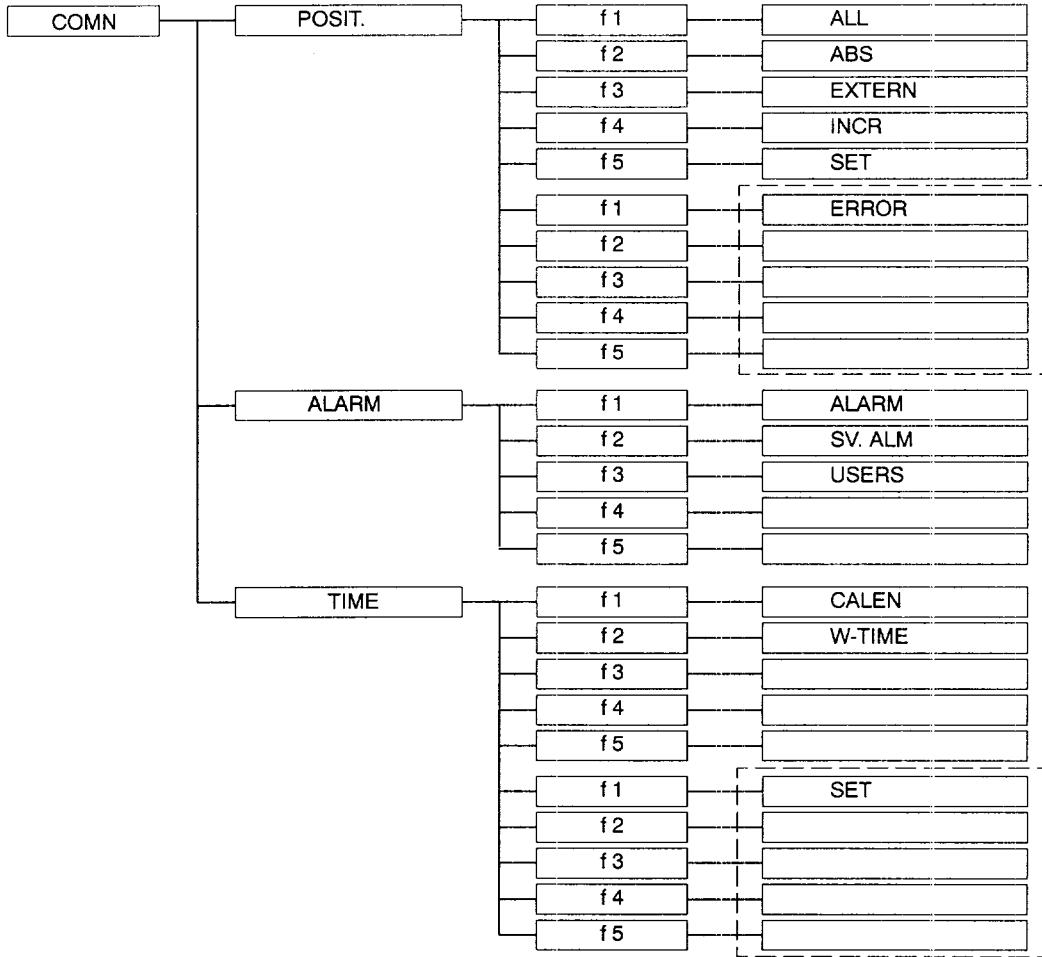

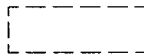
 : Functions displayed by pressing the FUNCTION SELECTION key

3.2 NC OPERATION PANEL

This section describes the configuration of the NC operation panel and the editing function.

3.2.1 Keys and Display Screen on NC Operation Panel

NC operation panel of YASNAC J300 series is shown in Fig. 3.2.

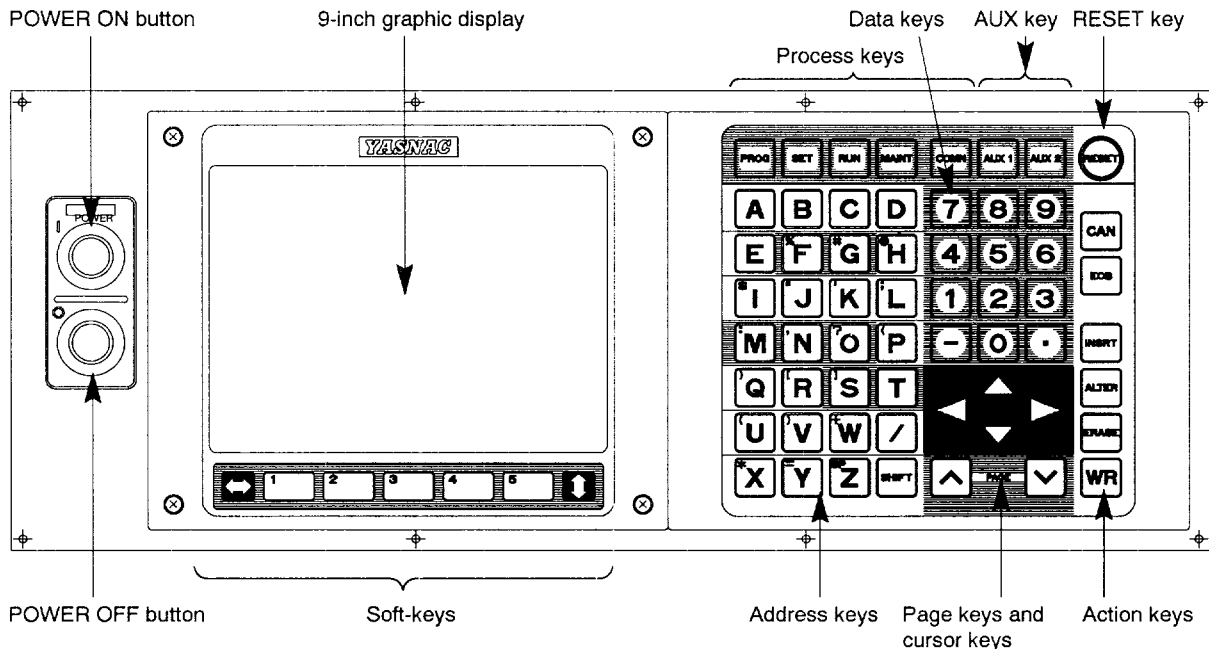

Fig. 3.2 Operation Panel

(1) POWER ON/OFF Buttons

(a) POWER ON button (Turning ON the power to the NC unit)

Power is supplied in two steps of operation. In the first, pressing of the POWER ON button, power is supplied to the control unit, and power is supplied to the servo the second time the POWER ON button is pressed. With some models of machines, power will be supplied to the servo in the first pressing of the POWER ON button. For details, refer to the manuals published by the machine tool builder. To turn ON the servo power after emergency stop or other similar operation, this button is also used.

(b) POWER OFF button (Shutting OFF the power to the NC unit)

The power is supplied to the control unit and servo is shut OFF by pressing the POWER OFF button.

(2) 9-inch Graphic Display (CRT)

Data are displayed in different sizes of characters in the range from 1×1 to 3×3 magnification.

Maximum number of characters	40 characters \times 20 lines (25 lines) = 800 characters (or 1000 characters) [in 1×1 scale]
Displayed characters	Numerals (0 to 9, -, .) Alphabets (A to Z) Special codes [/ (slash), EOB, +, #, SP, =, etc.]
Graphic display	640 \times 400 dots (high resolution type)

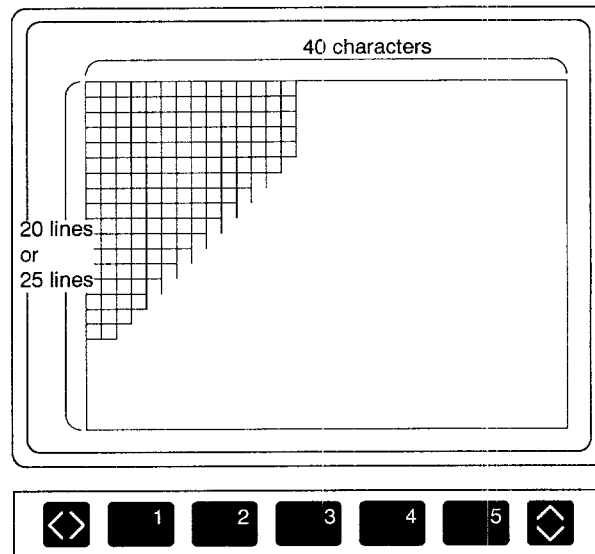

Fig. 3.3 9-inch Graphic Display

(3) Process Keys

The process keys are used to select the process. The following five process keys are provided and by pressing one of these keys, the corresponding process is selected.

- [PROG] Edit key : Selects the editing process.
- [SET] Set-up key : Selects the set-up process.
- [RUN] Operation key : Selects the operating process.
- [MAINT] Maintenance key : Selects the maintenance process.
- [COMN] Common key : Selects the common display or returns to each process.

(4) Soft-keys

The soft-keys are selection keys related to display and writing. The soft-keys are displayed in two rows (upper and lower) as shown in Fig. 3.4. The upper soft-keys are used to select jobs and the lower ones to select functions. By pressing the UP/DOWN SELECT key, the selection mode can be changed between the job selection mode and the function selection mode. The presently selected mode can be found from the UP/DOWN SELECT indicator on the CRT and also from the soft-keys.

In the job selection mode, selection of job soft-keys is possible and in the function selection mode, selection of function soft-keys is possible. If more than five functions are provided in the selected job, the next set of functions are displayed by pressing the FUNCTION SELECT key. The selected job or function is highlighted.

3

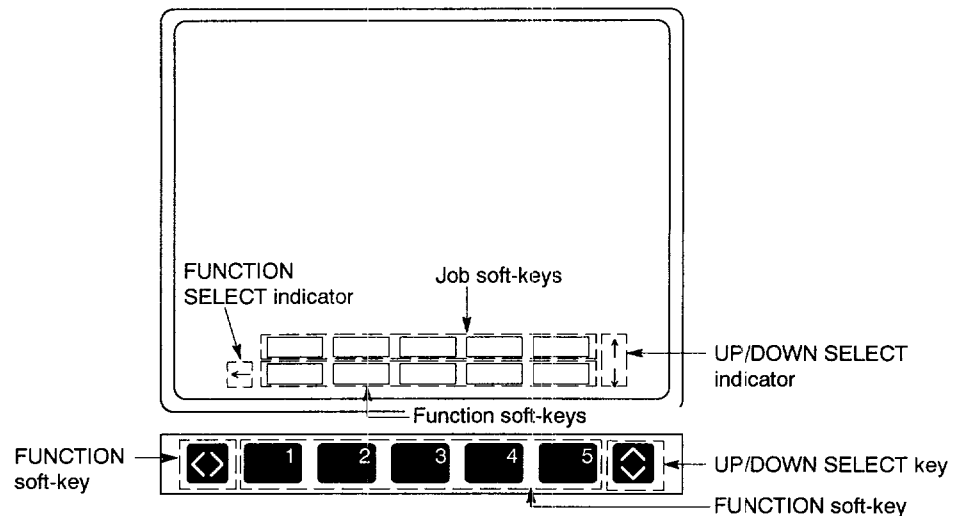
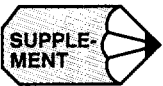

Fig. 3.4 Soft-keys



When there are more than five function soft-keys, the FUNCTION SELECT indicator is displayed as shown in Fig. 3.4.

When the UP/DOWN SELECT indicator is moved, the box moves up or down.

When the box is in the upper position, it indicates the job selection mode and if it is in the lower position, it indicates the function selection mode.



◆ Soft-key

The soft-keys indicate the menu frames displayed at the lower part of the CRT. Selection of menu is accomplished by pressing the key located at the corresponding position.

(5) Address Keys

The address keys are used to specify the addresses when writing data.

- [/] Slash key : The slash key is used to indicate the optional skip command.
- [SHIFT] Shift key : To display special characters such as “%” and “#”, press the address keys of F to Z on which the corresponding special character is indicated while pressing the [SHIFT] key.

(6) Data Keys

The data keys are used to write numerical values such as command values, tool offset amounts, and settings for parameters.

- [0] - [9] Numeric keys : Used to enter numerals.
- [-] Minus key : Used to enter a minus sign.
- [.] Decimal : Used to enter a decimal point.
 point key

(7) Page Keys

Display given on the screen is assumed as “page”, and these keys are used to change the display page to the previous or next page.

- [^] page up key : Used to display the previous page.
- [v] page down key : Used to display the next page.

When a page key is held pressed, the display page changes continuously.

(8) Cursor Keys

The cursor keys are used to move the cursor on the screen up/down and right/left. When the cursor is positioned at a certain position on the screen, that position is highlighted. In this manual, the position displayed in highlighted block is called the cursor.

(a) Moving the cursor up/down

When a set of parameter data is displayed with parameters selected, the up/down cursor keys are used to move the cursor to the required parameter position.

[▲] cursor up key : Used to move the cursor up.

[▼] cursor down key : Used to move the cursor down.

When the cursor up or down key is held pressed, the cursor moves continuously.

It is also possible to move the cursor to the required position by specifying the required number; enter the required number and press the cursor up or down key, and the cursor moves to the specified position.

(b) Moving the cursor right/left

[◀] cursor left key : Used to move the cursor left.

[▶] cursor right key : Used to move the cursor right.

(9) Action Keys

The action keys are used for various applications. When an action key is pressed, display on the screen will be changed by such as entered data.

[CAN]	Cancel key	: Used to cancel typing error of numerals or address data.
[EOB]	End of block key	: Used to indicate the end of a block. “;”(semicolon)is displayed on the screen instead of EOB.
[INSRT]	Insert key	: Used to insert data to the memory.
[ALTER]	Alter key	: Used to correct data in the memory
[ERASE]	Erase key	: Used to erase data in the memory
[WR]	Write key	: Used to store address data (=word) keyed in by using the address keys and data keys

(10) RESET Key

The RESET key is used to reset the internal state of the NC unit. When the RESET key is pressed, the following items are executed.

- Cancels the move commands.
- Clears the buffer area.
- Resets the alarm (after removing the cause).
- Cancels the tool offset.
- Cancels the miscellaneous function.
- Turns ON the label skip function.
- Rewinds the memory. (Returns the program execution pointer to the beginning of the program.)

Whether or not the memory rewind is executed is determined by the setting for the parameter.

pm4008 D0 = 0	Memory rewind is executed.
pm4008 D0 = 1	Memory rewind is not executed.

If “pm4008 D0 = 0”, memory rewind is executed by pressing the [SRCH] soft-key.

- Sends the reset signal.
- Resets the G code.
- Clears the key buffer area.

Note that the following items are not influenced by the reset operation.

- Present position data of the axes
- F command
- S and T commands
- Tool offset amounts, setting data, and parameter data

(11) AUX Key

The AUX key is used for the future expansion of the functions.

[AUX1], [AUX2] keys: Used for optional functions.

3.2.2 Normal Display on CRT Screen

Independent of the selected process, job, and function, the following information is always displayed at the top line and the lower five lines as shown in Fig. 3.5.

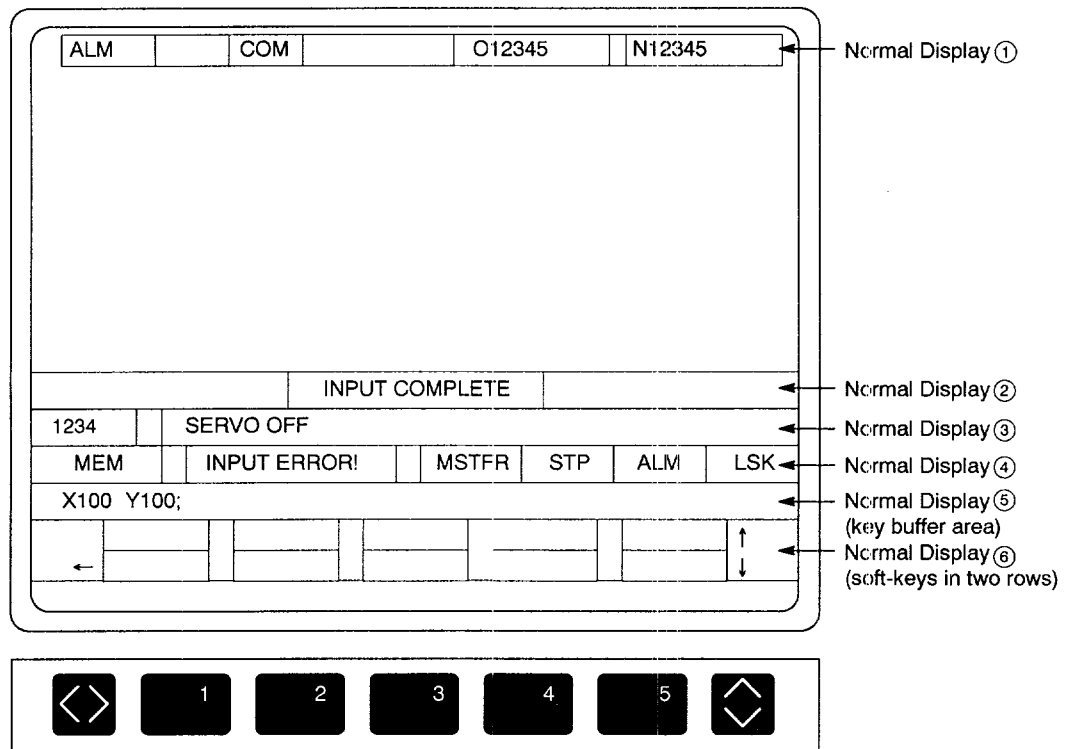

3

Fig. 3.5 Normal Display on the Screen

Contents of normal display are indicated in Table 3.1.

Table 3.1 Contents of Normal Display

Normal Display	Item	Message	Meaning
①	Screen title display	ALM OFFSET ... etc.	Job name of the selected screen is displayed as the title.
	Process display	EDT AUX1 SET AUX2 MNT COM	The selected process name is displayed.
	Display of selected system	TOOL REST 1 TOOL REST 2	The name of the selected system. This display is not given for the NC unit that has only one control system. Selection from seven patterns is possible by the setting for parameter pm3105.
	Program number display	O***** O00001 - O99999	The number of the program operating in the selected series is displayed. O***** indicates that program number is not selected.
	Sequence number display	N00000 - N99999	The present sequence number of the selected series is displayed.
②	Display of operation results and guide messages	INPUT? (Y/N) INPUTTING INPUT STOPPED INPUT COMPLETE OUTPUT? (Y/N) OUTPUTTING OUTPUT STOPPED OUTPUT COMPLETE VERIFY? (Y/N) VERIFYING VERIFICATION STOPPED VERIFICATION COMPLETE CREATE ? (Y/N) CREATION COMPLETE COPY? (Y/N) COPY COMPLETE RENAME ? (Y/N) RENAMING COMPLETE DELETE ? (Y/N) DELETION COMPLETE SELECT OTHER JOB PUSH EXEC TO CONTINUE EXECUTING STOP?(Y/N) SEARCH COMPLETE	Result of key operation and the NC execution state are displayed.

Table 3.1 Contents of Normal Display (cont'd)

Normal Display	Item	Message	Meaning
②	Display of operation results and guide messages	INPUT O NO. INPUT COMMENT SAVING COMPLETE TRANSFER PARM ? TRANSFERRING PARM TRANSFER COMPLT INPUT O NO. SAVING SEARCHING INPUT? (PUSH Y) OUTPUT? (PUSH Y) VERIFY? (PUSH Y) OK? (Y/N) MODE IS UNSUITABLE SEARCH STOPPED INPUT O NO. (DELETE) DELETE ALL? (Y/N) INPUT OLD O NO. INPUT ORIGINAL O NO. INPUT NEW O NO. INPUT O NO. (COPY) CLEAR ALL OFFSETS? (Y/N) SEARCH COMPLETE INPUT OLD STRING INPUT NEW STRING (Yes/No/All) ?	Result of key operation and the NC execution state are displayed.
③	Alarm number display	0001 - 9999	The top priority alarm occurring in the selected series is displayed. If there is no alarm in the selected series, the top priority alarm of the other series is displayed.
	Alarm message display	TH error Character cannot be used External data input error etc.	The message of the top priority alarm occurring in the selected series. If there is no alarm in the selected series, the alarm message of the top priority of the other series is displayed.
	Display of system involved with alarm	TOOL REST 1 TOOL REST 2	If an alarm message is displayed, this indicates the control system involved with the alarm.
④	Operation mode	Edit Memory MDI Communication Step Handle Jog Rapid feed	The operation mode of the selected series is displayed.

Table 3.1 Contents of Normal Display (cont'd)

Normal Display	Item	Message	Meaning
④	Warning display	INPUT ERROR ! O NO. NOT FOUND ! NOT FOUND ! ALREADY IN ! OVER MEM CAP ! TOO MANY PROGS ! VERIFY ERROR ! MACRO LOCK ! LINE LOCK ! RUNNING PROGRAM ! NC RUNNING ! FORMAT ERROR ! EDIT LOCK ! NOT FOUND ! ALREADY EDIT ! SELECT MODE ERR ! COPY MODE ERROR ! MOVE MODE ERROR ! PRM SETTING ERROR ! CAN'T SET COORD ! OVER MDI BUFFER ! PRM SETTING ERR ! READING PROGRAM ! EDITING PROGRAM ! IMPOSS COLLECT ! EDIT LOCK ! OFFSET ERROR ! OVER MEM CAP ! RUNNING PROGRAM ! TOO LARGE AREA ! ALREADY IN ! NC RUNNING ! BREAK POINT ! SYSTEM NO.1 ! CAN'T WRITE! ADDRESSING ER! AXIS MOVING! RESTARTING PROG! CAN'T SET COORD!	Warning indicates lower priority error, which does not cause operation stop. Reset the error by key input, mode change, screen switching.

Table 3.1 Contents of Normal Display (cont'd)

Normal Display	Item	Message	Meaning
④	Operation status	M/S/T/F/R DWELL	Indicates the status of the selected series. M, S, T: Waiting for the completion of the specified code. F: During cutting, R: During rapid traverse, DWELL: During dwell.
			Indicates the status of the selected series.
		STP	Indicates that the NC stopped.
		RST	Indicates that the NC is in reset status.
		BUFn	Indicates that the NC is in the n-block buffering status.
	Alarm status		Indicates the status of the selected series.
		ALM	Indicates that an alarm has occurred.
		BAT	Indicates that the battery alarm has occurred.
		A/B	Indicates that both an alarm and a battery alarm have occurred.
		BGA	Indicates that a background alarm has occurred.
		B/B	Indicates that both a background alarm and a battery alarm have occurred.
	Label skip	LSK	Displayed when label skip is ON.
	⑤	Key buffer	
⑥	Soft-key		Selection key for display and writing (in two rows - up and down)

3.2.3 Pop-up Menu

The pop-up menu is used to select a menu item in the selected function. Usually, there is only a single menu item in a function. The pop-up menu is used to select the menu if there is more than one menu item in the selected function. The soft-keys that support the pop-up menu are distinguished by the soft-key frame with a double-line at the left side.

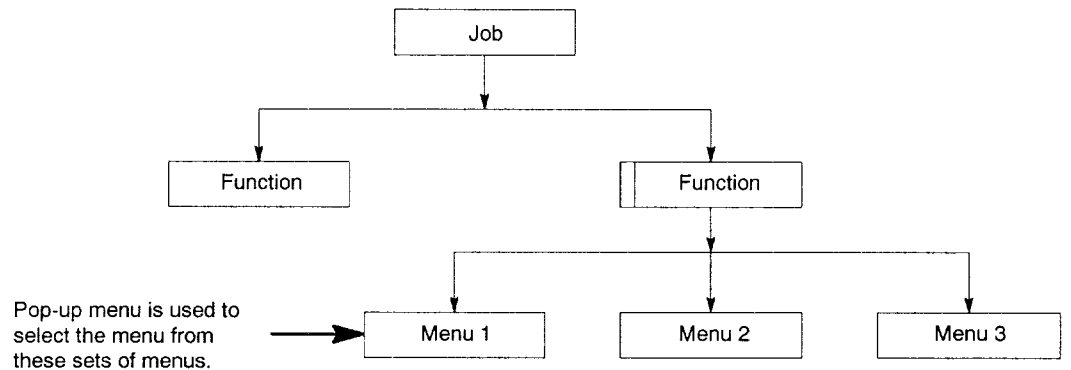

If the [DELETE] soft-key is pressed, the pop-up menu is displayed. Selection by the pop-up menu is made by using the UP/DOWN SELECT key and the [WR] key. The pop-up menu is cleared when the selection is finished.

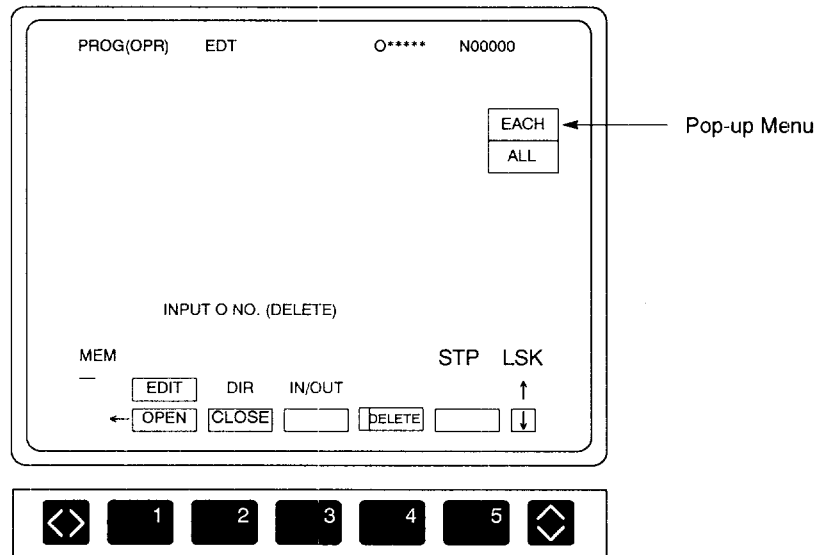

Fig. 3.6 Pop-up Menu for DELETE Function

3.2.4 Key Buffer Edit Function

For the data keyed in by key operation and displayed at the key buffer area on the CRT screen, insertion and deletion of characters are allowed. This key buffer area edit function is helpful to correct the entered data in the following cases.

- The user finds an error immediately after keying in the data.
- The keyed in data could not be entered with the “INPUT ERROR!” warning message displayed even when the [WR] key was pressed.

(1) Key Buffer Cursor

The underline cursor “ ” blinks at the beginning of the key buffer area. This underlined cursor is the key buffer cursor. It moves to the right as characters are keyed in and is displayed after the last character.

(2) Moving the Key Buffer Cursor

With characters keyed in to the key buffer area, the underlined cursor moves in response to the operation with the cursor right/left keys. The underlined cursor is valid in the key buffer area but not for the contents displayed on the screen. However, if there are no characters keyed in to the key buffer, the underline cursor is valid for the contents displayed on the screen. Examples of the key buffer edit operation are explained below.

(a) Deletion

G00 X100.Z100.;

To delete “X100.” while the data indicated above are keyed in to the key buffer area.

- ① Move the key buffer cursor back to “Z” by pressing the cursor left key.

G00 X100. Z100.;

- ② Press the [CAN] key five times to delete “X100.”.

G00 Z100.;

When the [CAN] key is pressed, the last character before the key buffer cursor is deleted. If the key buffer cursor is at the beginning of the key buffer area, pressing the [CAN] key has no effect and no characters are deleted.

(b) Insertion

X100.Z100.; __

To insert “G00” before “X100.” while the data indicated above are keyed in to the key buffer area.

- ① Move the key buffer cursor back to “X” by pressing the cursor left key.

X100. Z100.;

- ② Key in “G00”. The keyed in characters are inserted before the key buffer cursor.

G00 X100. Z100.;

3.2.5 Buzzer Function

It is possible to sound the buzzer for each key operation at the NC operation panel. Whether the buzzer should be sounded or not can be selected by the setting for the parameter.

pm0007 D7 = 0	No buzzer sound
pm0007 D7 = 1	With buzzer sound

4

EDIT PROCESS OPERATION

Chapter 4 describes the operation carried out by using the edit process keys. In the edit process a part program is created using the edit job, part program directory job, part program input/output and verify job.

Job selection is possible by using either the [EDIT] job soft-key or the [PROG] process selection key.

The operation indicated above can be executed any time independent of the NC operation mode even while automatic operation is being executed.

4

4.1	PART PROGRAM EDIT JOB	4 - 3
4.1.1	Calling a Part Program	4 - 4
4.1.2	Editing a Part Program	4 - 7
4.1.3	Saving a Part Program after Editing	4 - 22
4.1.4	Deleting a Part Program	4 - 23
4.2	PART PROGRAM DIRECTORY JOB	4 - 26
4.2.1	Display of the Directory of Part Programs	4 - 26
4.2.2	Calling a Part Program	4 - 33
4.2.3	Deleting a Part Program	4 - 35
4.2.4	Renaming a Part Program	4 - 37
4.2.5	Copying a Part Program	4 - 39

4.3 PART PROGRAM INPUT/OUTPUT
AND VERIFY JOB 4 - 40

- 4.3.1 Inputting a Part Program 4 - 40
- 4.3.2 Outputting a Part Program 4 - 44
- 4.3.3 Verifying the Part Programs 4 - 51
- 4.3.4 Setting the Communication Conditions 4 - 55
- 4.3.5 Other Function 4 - 60

4.1 PART PROGRAM EDIT JOB

To select the part program edit job, press the [EDIT] (f1) job soft-key. In the part program edit job, the following functions are provided.

- Calling a part program
- Editing a part program
- Saving a part program
- Deleting a part program

Optionally, editing up to three part programs is simultaneously possible. The standard program storage capacity is 16 KB (40 cm in tape length) and this capacity can be optionally expanded to 32 KB, 64 KB, 128 KB, 256 KB, 512 KB, 1024 KB, or 2048 KB.

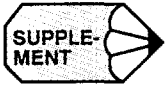

1. If a process key other than [PROG] is pressed while editing a part program, the part program is temporarily saved. The interrupted editing can be continued after pressing the [PROG] key.
2. Do not turn OFF the power during editing. Before turning OFF the power, the part program(s) must be saved.

4.1.1 Calling a Part Program

Call the program to be edited. To call a program not existing in the memory, create it before calling.

(1) Using the [EDIT] (f1) Job Soft-key

Basic and optional operation is possible by using the [EDIT] (f1) job soft-key.

(a) Basic operation

Carry out the basic operation in the following procedure.

- ① Press the [EDIT] (f1) job soft-key.
- ② Press the [OPEN] (f1) function soft-key. (This step can be skipped.)
- ③ Key in the program number of the program to be called by using the address and data keys (O111, for example). If a new program number is keyed in and the [WR] key is pressed in this step, it is registered as a program and can be called in later operation.
- ④ Key in a comment with the address keys and press the [WR] key. (This operation is necessary even when a comment is not entered.)

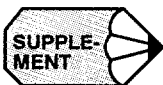

-
1. In the edit lock state, it is not allowed to create a new program number. Reset the edit lock state before creating a new program number.
 2. The program presently executed can also be called. However, it is not allowed to edit such a program after calling it to the screen.
 3. While the EDIT LOCK switch is ON, the edit function keys ([INSRT], [ALTER], and [ERASE]) and NC tape loading operation are invalid.
 4. If program editing is attempted with the EDIT LOCK switch ON, the warning message "EDIT LOCK !" is displayed.
-

The contents of the called part program are displayed as indicated below.

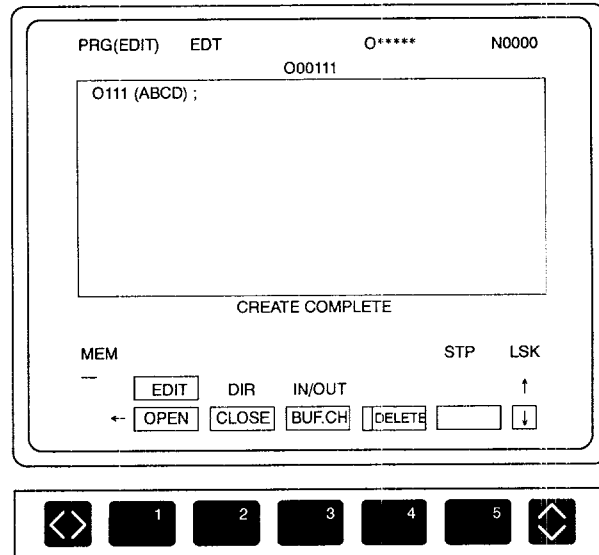

Fig. 4.1 Contents of the Called Part Program

4

(b) Option operation

Optionally, up to three part programs can be called at the same time. To call another program, press the [OPEN] (f1) function soft-key. The message "INPUT O NO." is displayed. Execute steps ③ and ④ in (a). Examples of screens where two or three part programs are called are shown in Figs. 4.2 and 4.3.

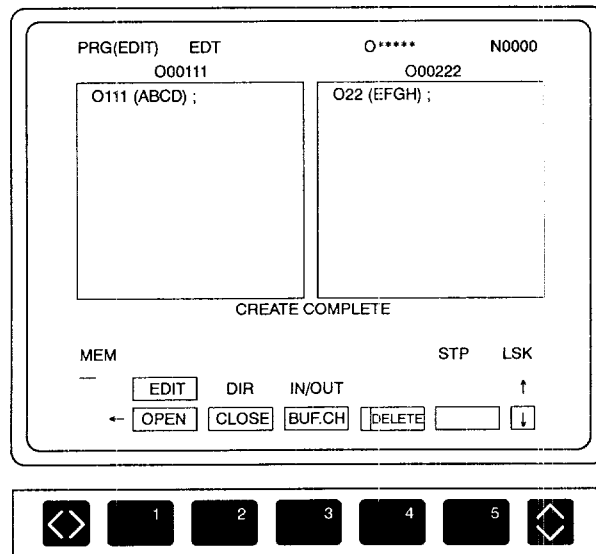

Fig. 4.2 Display Screen with Two Part Programs

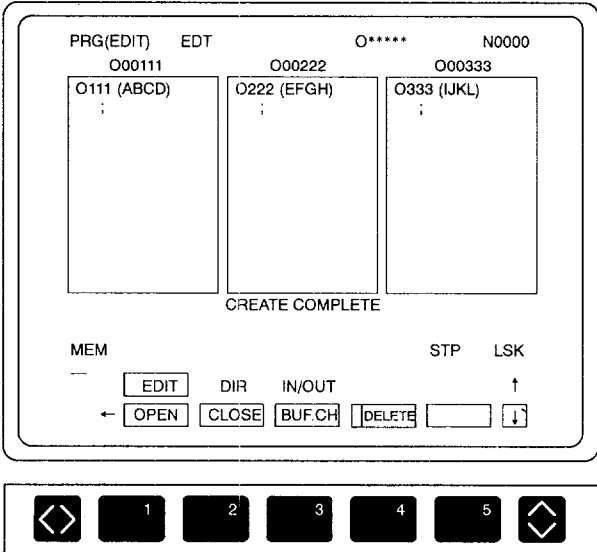

Fig. 4.3 Display Screen with Three Part Programs

(2) Using the [BUF. CH] (f3) Soft-key

If the part program to be called is within the allowable range of program call, the specified program can be called. However, if calling a new part program causes the allowable range of program call to be exceeded, the program selected by the [BUF. CH] (f3) function soft-key is saved automatically before calling the specified program.

A part program can be called without using the [OPEN] (f1) function soft-key. Follow the procedure indicated below.

- ① After keying in the program number of the program to be called, press the [WR] key. When the existing program number is entered, the specified program is called. If a program number not existing in the memory is entered, the message "INPUT COMMENT" is displayed indicating that the specified program number is a new program number.
- ② Key in a comment and press the [WR] key.

4.1.2 Editing a Part Program

The procedure for editing the part program called to the screen is explained below. Optionally, the expansion editing functions (copy, move, and alter and erase with range specification) can be used. Select the part program to be edited in the following procedure.

- ① If more than one program has been called, press the [BUF. CH] (f3) soft-key several times until the cursor moves to the program number of the program to be edited.

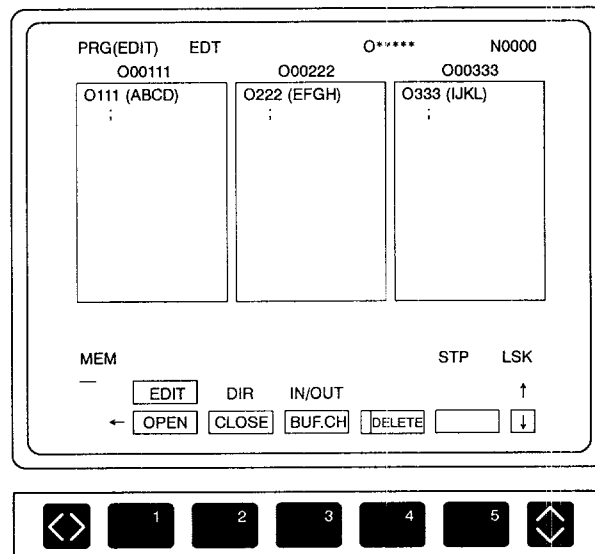

Fig. 4.4 Part Program Editing Screen

- ② For editing a part program, the following keys are used: function soft-keys ([SELECT] (f1), [COPY] (f2), [MOVE] (f3), [REPL] (f4), and [BT/TOP] (f5)), function keys ([INSRT], [ALTER], and [ERASE]), cursor keys (up/down, right/left), page keys, etc.

(1) Inserting a Word

By pressing the [INSRT] key, new data can be inserted immediately after the word specified by the cursor. Follow the procedure indicated below.

- ① Move the cursor to the word immediately before the position where a new word should be inserted (for example, “;”).

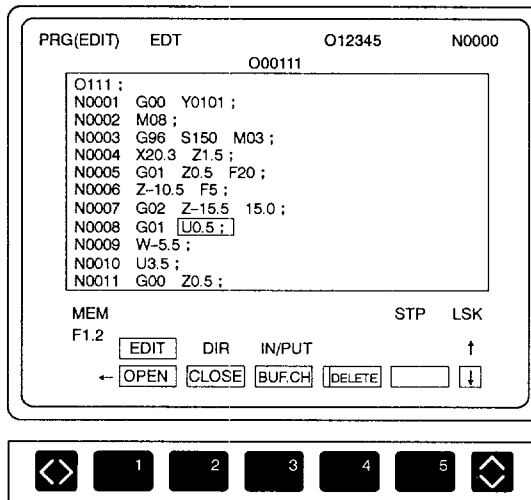

Fig. 4.5 Screen before Word Insertion

- ② Key in the word to be inserted (“F1.2”, for example) by using the address and data keys and press the [INSRT] key.

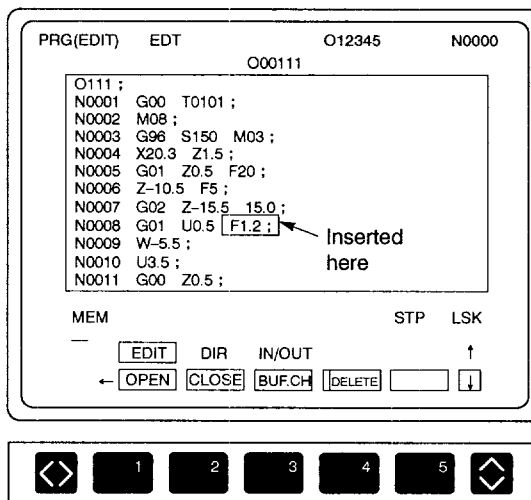
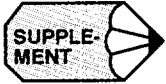

Fig. 4.6 Screen after Word Insertion



After inserting a word, the cursor indicates the word entered last. The insertion operation allows more than one word (within 40 characters) to be inserted at a time.

(2) Altering a Word

By pressing the [ALTER] key, the word specified by the cursor is erased and replaced with a new word. Follow the procedure indicated below.

- ① Move the cursor to the word to be altered (for example, "X20.3").

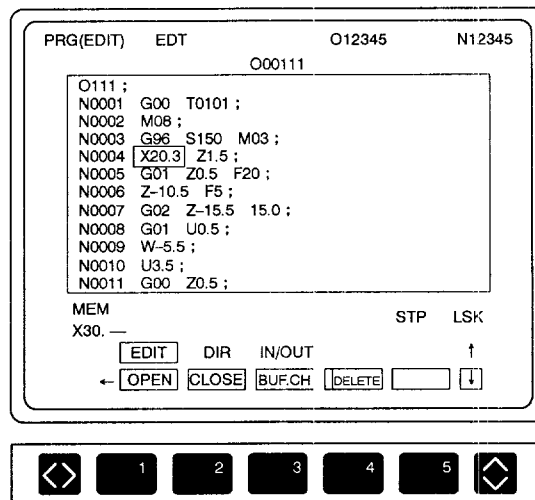

Fig. 4.7 Screen before Alter

- ② Key in the word (“X30.”, for example) that replaces the cursor specified word by using the address and data keys and press the [ALTER] key. The word specified by the cursor is erased and replaced with the keyed in new word.

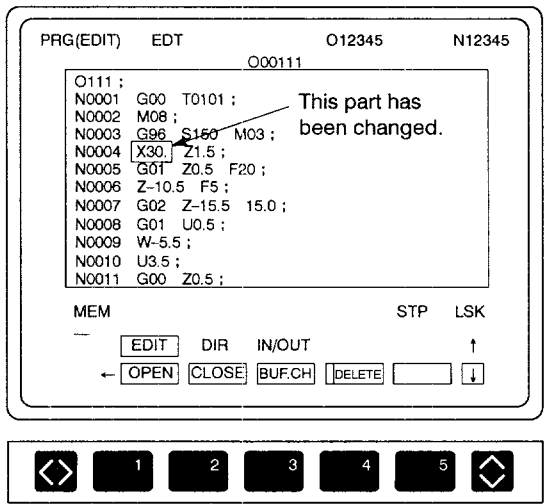

Fig. 4.8 Screen after Alter



In this operation, if more than one word (within 40 characters) is keyed in, the specified word/words are replaced with keyed in words.

(3) Erasing a Word

By pressing the [ERASE] key, the word specified by the cursor is erased. Follow the procedure indicated below.

- ① Move the cursor to the word to be erased (for example, "F20").

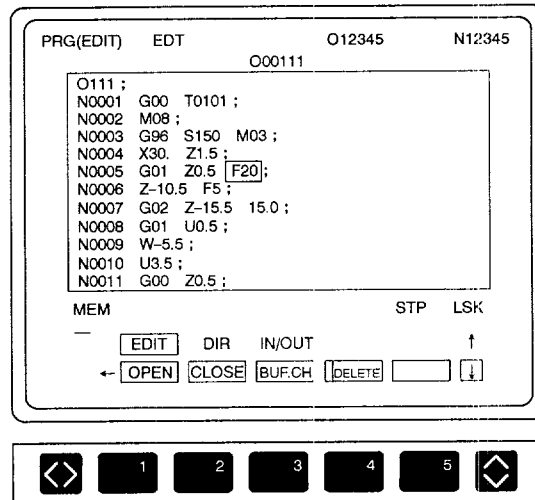

Fig. 4.9 Screen before Erasing

- ② Press the [ERASE] key. Only the specified word is erased.

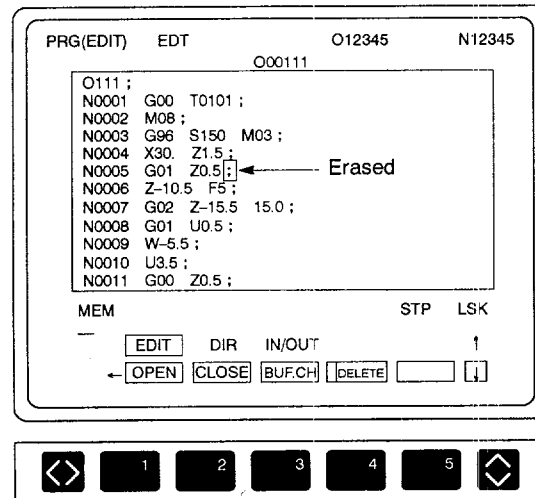

Fig. 4.10 Screen after Erasing

(4) Search and Erase Function

The search and erase function erases the characters in the specified range, from the present cursor position to the specified character-string. Follow the procedure indicated below.

- ① Move the cursor to the first character of the character-string to be erased (for example, “N0007”).

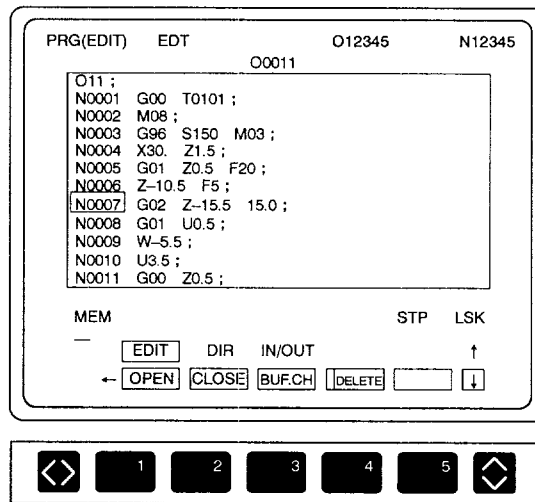

Fig. 4.11 Specifying the First Character in the Character-string to be Erased

- ② Key in the last word of the range to be erased (for example, “Y0” if the part program should be erased up to “U0.5” in the “N0008 G01 U0.5;” block) and press the [ERASE] key. The specified range is highlighted. At the same time, the message “DELETE OK ? (Y/N) ?” is also highlighted.

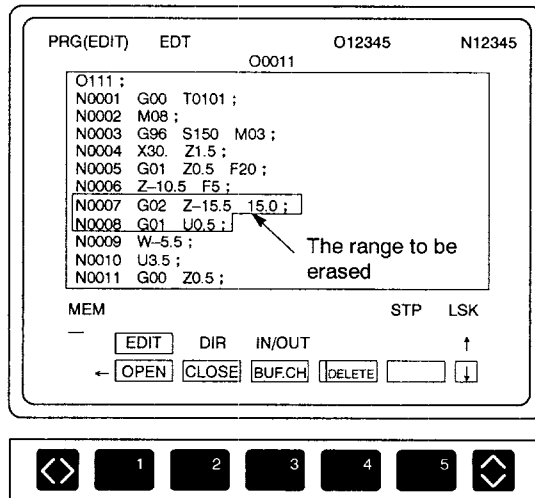

Fig. 4.12 Screen for Specifying the Range to be Erased

- If the specified word is not found in the part program, the warning message “NOT FOUND !” is displayed.
 - While the message “DELETE OK? (Y/N)” is displayed on the screen, word insertion, alter, and erase operation are not allowed. If any of the soft-keys calling such functions is pressed, the search and erase function is canceled.
 - To cancel the search and erase function, press the [RESET] key, [CAN] key, or address key [N]. After the pressing of the [RESET] or [CAN] key, the cursor moves to the position where it was located before the specification of the range. In the case of the address key [N], the cursor is located at the position where it was located after the specification of the range.
- ③ After confirming the range to be erased, press the [Y] key and the character-string in the highlighted range is erased.

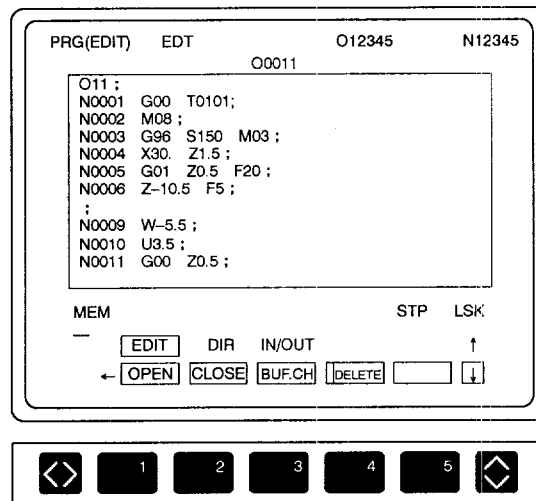

Fig. 4.13 Screen after Erasing the Range to be Erased



If the first character of the character-string specified for erasing, an O number is erased. This is not the search and erase function. For the search of character-string, binary search is used (leading zeros can be omitted).

(5) Moving the Cursor

- When the cursor up/down keys are pressed, the cursor moves up or down in units of the part program blocks. The cursor always moves to the beginning of the next or previous block.
- When the cursor right/left keys are pressed, the cursor moves right or left in units of words.
- When page keys are pressed, the part program display screen is scrolled up or down in units of pages.

(6) Address Search Function

Follow the procedure indicated below to execute the address search function.

- ① Key in the character-string to be searched for.
- ② When the cursor down key is pressed, the search is made from the present cursor position to the end of the program. When the cursor up key is pressed, the search is made from the present cursor position to the beginning of the program. During search operation, the "SEARCHING" message is displayed on the screen.
- ③ Upon completion of the search, the message is cleared and the cursor is positioned at the found word.
- ④ If the specified word is not found, the warning message "NOT FOUND!" is displayed.
- ⑤ To search the same character-string continuously, press the cursor up or down key while holding down the [SHIFT] key. This executes the search operation again. Once the character-string to be searched is keyed in, the same character-string can be searched as many times as required unless another character-string is specified

(7) Copy Function

By pressing the [COPY] key, the registered character-string can be copied to the specified area.

Limit of character-string length: 1024 characters

Follow the procedure indicated below to executed the copy function.

- ① Move the cursor to the first character of the character-string to be copied (for example, “N0003”).

- ② Press the [SELECT] (f1) function soft-key.

The function name “SELECT” is highlighted indicating that the selection mode is selected. If the [SELECT] (f1) function soft-key is pressed while it is highlighted, the selection mode is canceled.

- ③ Move the cursor to the last character of the character-string to be copied. The specified character-string are displayed highlighted.

- ④ When the [COPY] (f2) function soft-key is pressed, the selected character-string is saved and, at the same time, “*” symbol appears at the start of the [COPY] (f2) function soft-key. Display of the character-string returns to the normal mode.

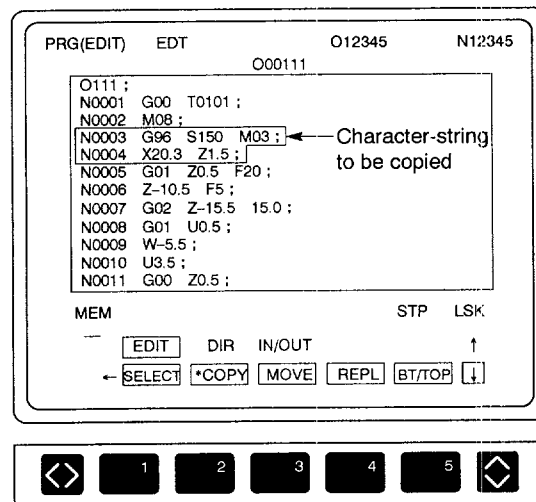

Fig. 4.14 Screen for Specifying the Character-string to be Copied

- ⑤ Move the cursor to the position where the specified character-string should be copied (“;” that follows “N0010”, for example).
- ⑥ Press the [*COPY] (f2) function soft-key, and the specified character-string is copied to the position indicated by the cursor.

- ⑦ While “*COPY” is displayed, the same character-string can be copied as many times as required by simply pressing the [*COPY] (f2) function soft-key.

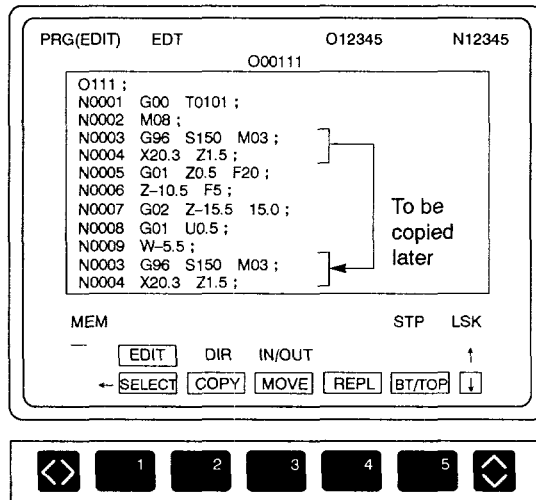
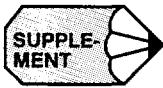

Fig. 4.15 Copy Screen



1. When the power is turned OFF, selection of the character-string is cancelled and the “*” symbol is cleared.
2. When executing program edit by displaying more than one program, it is possible to copy the same character-string if the edit objective program is changed.
3. If the move function is used after using the copy function, selection of the character-string for the copy function is cancelled.
4. If the number of characters in the selected character-string exceeds 1024 characters, the warning message “MEM AREA OVER !” is displayed.

(8) Move Function

By pressing the [MOVE] key, the registered character-string is moved to the specified position.

Limit of character-string length: 1024 characters

Follow the procedure indicated below to execute the move function.

- ① Specify the character-string to be moved in the same manner as with the copy function after pressing the [SELECT] (f1) function soft-key. The selected character-string is displayed in white characters.

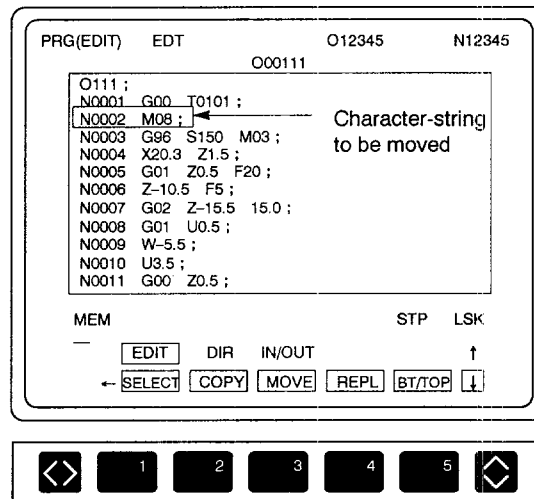

Fig. 4.16 Specifying the Character-string to be Moved

- ② When the selected character-string is saved by pressing the [MOVE] (f3) function soft-key, the "*" symbol appears at the beginning of the soft-key function name. The character-string, displayed in white characters, is deleted from the screen.
- ③ Move the cursor to the position where the selected character-string should be moved.
- ④ When the [MOVE] (f3) function soft-key is pressed, the specified character-string is moved to the position indicated by the cursor.

- ⑤ While “*MOVE” is displayed, the same character-string can be moved as many times as required by simply pressing the [*MOVE] (f2) function soft-key.

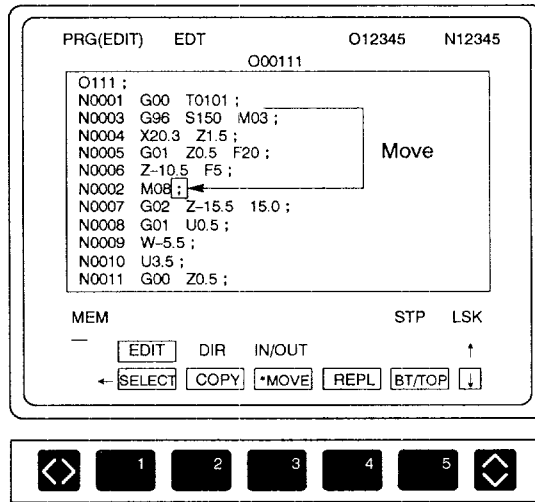
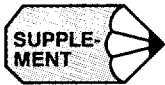

Fig. 4.17 Screen after Move



1. When the power is turned OFF, selection of the character-string is cancelled and the “*” symbol is cleared.
2. When executing program edit by displaying more than one program, it is possible to move the same character-string if the edit objective program is changed.
3. If the copy function is used after using the move function, selection of the character-string for the move function is cancelled.
4. If the number of characters in the selected character-string exceeds 1024 characters, the warning message “MEM AREA OVER !” is displayed.
5. It is not allowed to move the range including an O number given at the beginning of a program. If move operation is attempted after specifying the range which includes an O number, the warning message “MOVE MODE ERROR !” is displayed.

(9) Replace Function

By pressing the [REPL] key, this function searches the specified character-string and replaces it with the new character-string. Follow the procedure indicated below to execute the replace function.

- ① When the [REPL] (f4) function soft-key is pressed, the message “INPUT OLD STRING” is displayed.
- ② Key in the character-string to be replaced and press the [WR] key. The message “INPUT NEW STRING” is displayed. See the examples below.
 - To change “G00”, key in “G00” and press the [WR] key.
 - To change only address Y, key in “Y [SHIFT] [X]” and press the [WR] key.
 - To change only the data of “-160.0”, key in “[SHIFT] [X] -160.0” and press the [WR] key.

Note 1: The [SHIFT] and [X] keys can be pressed at the same time.

2: For the old character-string, only one word is allowed. If two or more words are specified, the warning message “INPUT ERROR !” is displayed.

3: It is allowed to use a wild card “*” when specifying an old character-string.

Use a wild card as a substitute for an unknown character in the address part or a numeral in the data part.

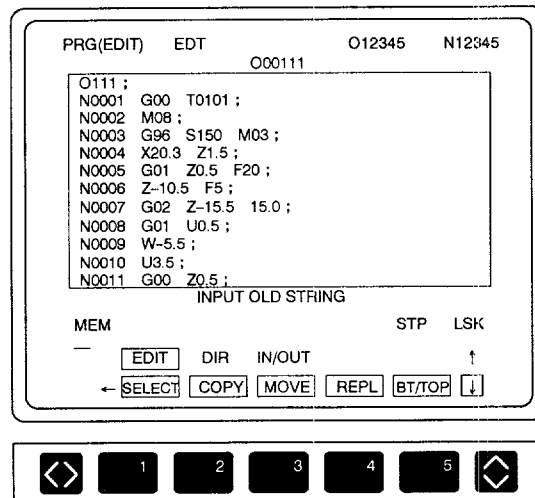

Fig. 4.18 Replace Screen



1. Only one wild card can be used. If two or more wild cards are used, the “INPUT ERROR !” warning message is displayed.
2. If a wild card is used, it is disregarded and search is executed with the rest of the character-string.
3. The replace function is valid for the character-string appearing after the cursor. If an attempt is made to replace the character-string before the cursor, the replace processing completes at the time the [WR] key is pressed.
4. If the character-string specified is not found, the “NOT FOUND !” warning message is displayed.

- ③ Key in the new character-string (for example, “G01”) and press the [WR] key.
 - To change the all of address of “Y*” to “Z”, key in “Z [SHIFT] X”.
 - To change the data part to “10.5”, key in “[SHIFT] X 10.5”.
 - For a new character-string, more than two words can be specified.
 - The new character-string must begin with an address. Otherwise the “INPUT ERROR !” warning message is displayed.
 - A wild card can be used in the new character-string only when a wild card is used in the old character-string.
 - The wild card must be used in the same part (address or numeral) as it is used in the old character-string.

Example

Old Character-string	New Character-string	Remark
*10.0	*-10.0	
Y*	Z*	
10.0	Z	“INPUT ERROR !” occurs.

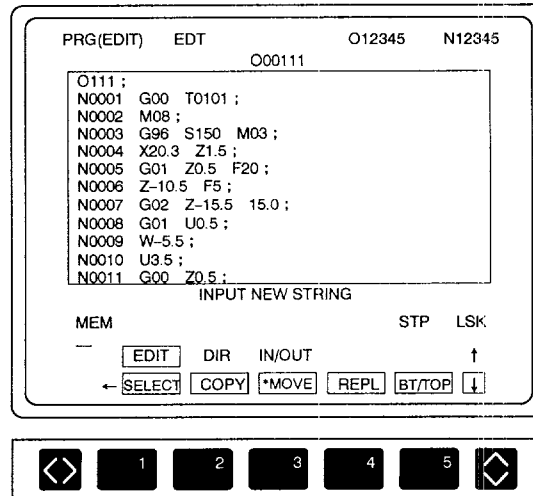
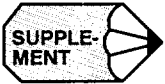
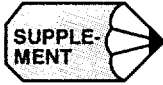

Fig. 4.19 Keying in New Character-string



If a wild card is used in the old character-string, only one word can be specified for the new character-string. If more than one word is specified in the new character-string, the warning message “INPUT ERROR !” is displayed.

- ④ The cursor moves to the character-string specified in step ②, and “(Yes/No/All)?” is displayed.
 - If “Y” is input, the character-string specified in step ② is replaced with the character-string specified in step ③. If there is another character-string that is the same as the one specified in step ②, the cursor moves to it. If the character-string specified in step ② is not found, the replace processing is completed.
 - If “N” is input, replace processing is not executed. If there is another character-string that is the same as the one specified in step ②, the cursor moves to it. If the character-string specified in step ② is not found, the replace processing is completed.
 - If “A” is input, all character-string specified in step ② are replaced with the character-string specified in step ③. During replace processing, “EXECUTING” message is displayed.
 - The replace function is cancelled by pressing the [RESET] key or [REPL] (f4) function soft-key once again.



While “(Yes/No/All)” is displayed on the screen, [SELECT], [COPY], [MOVE], and [BT/TOP], and other edit operations are not possible.

(10) Moving the Cursor to the Top or Bottom Line of the Program

When the [BT/TOP] function soft-key is pressed, the cursor moves to first address in the program displayed on the screen. Pressing the soft-key once again moves the cursor to the last address of the program displayed on the screen. Bottom line and top line are alternately selected each time the [BT/TOP] function soft-key is pressed.

4.1.3 Saving a Part Program after Editing

4

The called program must be saved after editing. The part program in the part program memory is updated only after the edited program is saved. After a part program is saved, another part program can be called.

Assume that the program numbers of the programs that have been called are displayed on the screen in the state as shown in Fig. 4.20. The following describes the procedure for saving the part programs under this state.

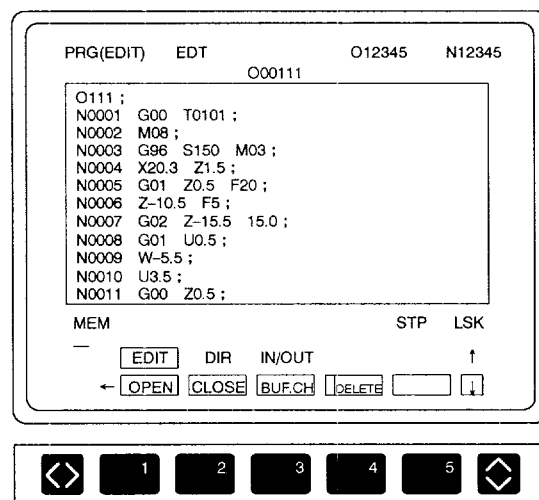

Fig. 4.20 Screen before Saving Part Program

- ① When the [BUF.CH] (f3) function soft-key is pressed, the cursor moves to the other program number. Select the program to be saved by using this function soft-key.

- ② Press the [CLOSE] (f2) function soft-key. The screen displays the contents of the program that has been selected to be saved.

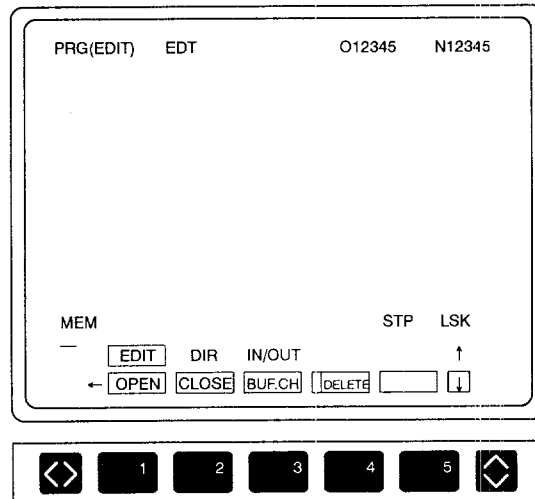

Fig. 4.21 Screen after Saving Part Program

4.1.4 Deleting a Part Program

For the deletion of a part program, the following two types of operation are provided.

[EACH] : Part programs are deleted one by one.

[ALL] : All part programs are deleted simultaneously.

In the edit lock status, part program deletion is not allowed. To delete a part program, cancel the edit lock status. During operation, the part program presently executed cannot be deleted. To delete the program being executed, delete it only after completing operation.

(1) Deleting a Part Program One by One

To delete a part program one by one, there are two methods: To use the [DELETE] (f4) function soft-key and to enter the program number.

(a) To use the [DELETE] (f4) function soft-key

Follow the procedure indicated below.

- ① When the [DELETE] (f4) function soft-key is pressed, the message “INPUT DEL O NO.” is displayed.

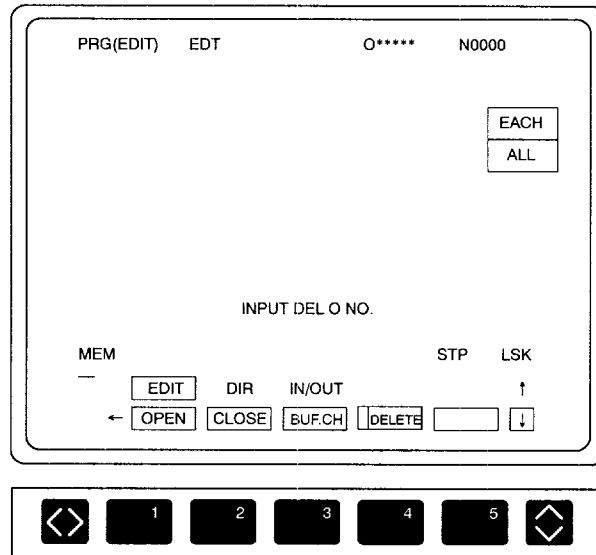

Fig. 4.22 Delete Menu Screen

- ② Key in the program number to be deleted (for example, “O123”) and press the [WR] key. The message “DELETE OK ? (Y/N)” is displayed.
 - Key in “Y” to delete the program. The designated program is deleted and the message “DELETE COMPLETE”. is displayed upon completion of program deletion.
 - Key in “N” when the program should not be deleted.

(b) To start with the entry of program number

Follow the procedure indicated below.

- ① Enter the program number of the program to be deleted.
- ② Press the [ERASE] key.
- ③ The message “DELETE OK? (Y/N)” is displayed.
 - Key in “Y” to delete the program. The “DELETE COMPLETE” message is displayed when the designated program is deleted.
 - Key in “N” when the program should not be deleted.

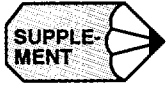

If the specified program number is not found, the “NOT FOUND O NO. !” message is displayed.

(2) Deleting All Part Programs

All part programs punched on a single tape can be deleted by selecting the [ALL] item in the pop-up menu.

Follow the procedure indicated below.

- ① Press the [DELETE] (f4) function soft-key.
- ② Press the [DELETE] (f4) function soft-key once again. The pop-up menu is displayed.
- ③ Press the cursor down key to select “ALL”.
- ④ Press the [WR] key. The pop-up menu for the delete menu selection is cleared. The message “DELETE ALL? (Y/N)” is displayed.
 - Key in “Y” to delete all part programs. The “DELETE COMPLETE” message is displayed when all programs are deleted.
 - Key in “N” if the part programs should not be deleted.

4



1. If the program specified to be deleted is called for editing, that program is automatically saved and deleted.
 2. If the program specified to be deleted has been called for operation, the program number for operation changes to “O*****” and the status before the selection of a program is recovered.
-

4.2 PART PROGRAM DIRECTORY JOB

Press the [DIR] (f2) job soft-key. In the directory job, the following functions are provided.

- Displaying the directory of part programs
- Calling part programs
- Deleting part programs
- Renaming part program
- Copying part programs

4.2.1 Display of the Directory of Part Programs

This function displays the directory of program numbers of the part programs stored in the NC memory. The display mode can be selected from the following three modes by pressing the [DSP.SL] (f5) function soft-key: with comment and date, with comment and the actually used number of characters, or program number only.

Display capacity of program numbers on one page is,

With comment : 10 program numbers

Without comment: 50 program numbers

- ① Press the [DIR] (f2) job soft-key. The directory of part program numbers is displayed.

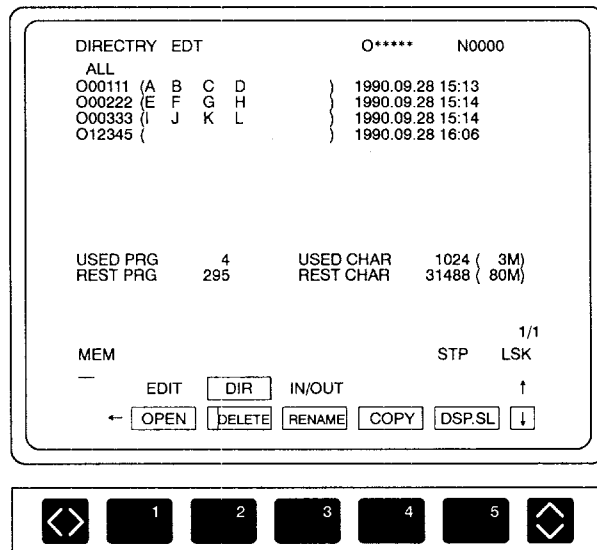
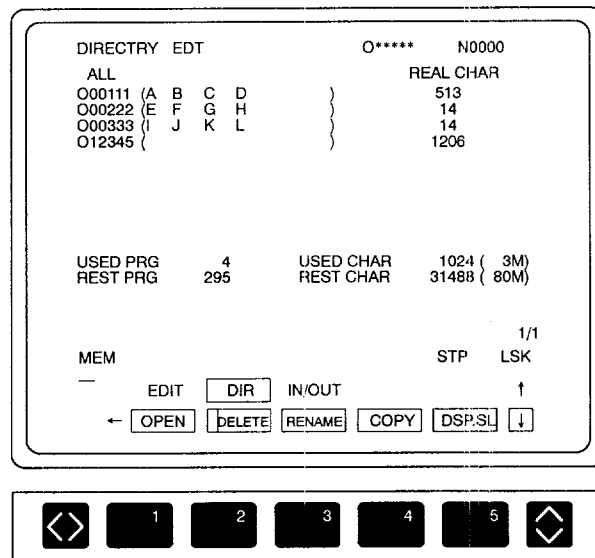

Fig. 4.23 Display of Part Program Directory with Comment and Date

- ② Press the [DSP.SL] (f5) function soft-key.

The display mode is changed cyclically in the order from “with comment and date” to “with comment and number of actually used characters”, then to “O-number only” as the [DSP.SL] function soft-key is pressed. From the “O-number only”, the display mode is changed back to “with comment and date”.

- An example of the display in “with comment and a number of actually used characters” mode is shown below.



4

Fig. 4.24 Part Program Directory Display with Comment and Number of Actually Used Characters



The number of actually used characters indicates the number of characters actually used in the individual programs. It is different from the number of used characters and the number of remaining characters. The number of used characters and the number of remaining characters indicate the number of characters occupying the memory area and they change in units of 256 or 1024, depending on the hardware specifications.

- An example of the display in “only O numbers” mode is shown below.

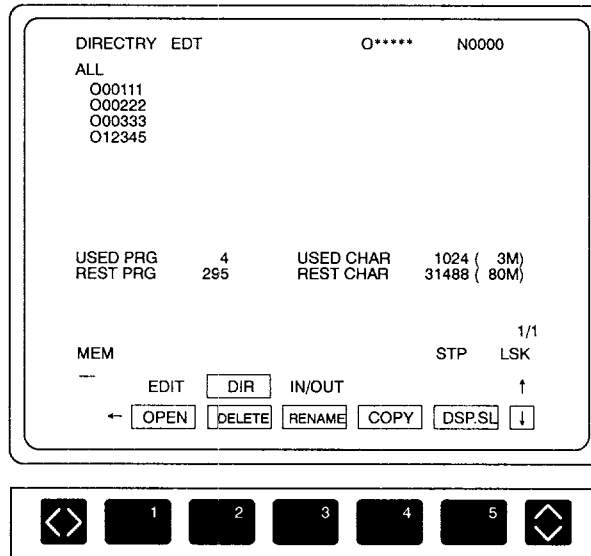

Fig. 4.25 Part Program Directory Display Screen without Comment and Date

For the display of the part program directory, the following four items can be selected from the menu; selection is made by pressing the [SELECT] (f1) function soft-key.

- ALL
- O NO. RANGE
- DATE RANGE
- COLLECT

For the display of related part programs (COLLECT), the [DSP.SL] function soft-key is invalid.

(1) Selection of All Programs

The directory of part program numbers of all stored part programs are displayed.

- ① Move the selection symbol to "ALL" by pressing the cursor up/down keys after pressing the [SELECT] (f1) function soft-key. In the initial state, "ALL" is selected.
- ② Press the [RETURN] (f5) function soft-key. The screen returns to the directory display screen and displays the directory of all program numbers.

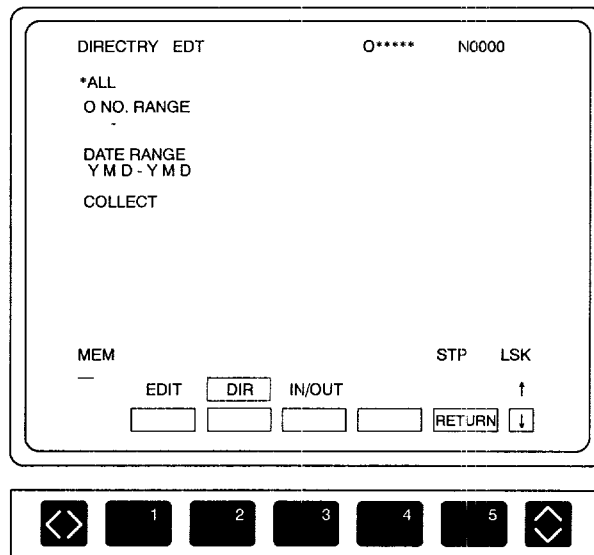

Fig. 4.26 Selection of "ALL"

(2) Selection of Program Number Range

The directory of program numbers of part programs in the specified range is displayed.

- ① Move the selection symbol to "O NO. RANGE" by pressing the cursor up/down keys after pressing the [SELECT] (f1) function soft-key. In the initial state, "ALL" is selected.
- ② Enter the first program number (for example, "O1000") and press the [WR] key.
- ③ Enter the last program number (for example, "O2000") and press the [WR] key.
- ④ Press the [RETURN] (f5) function soft-key. The screen returns to the directory screen and displays the directory of program numbers in the range from the first program number to the last program number.

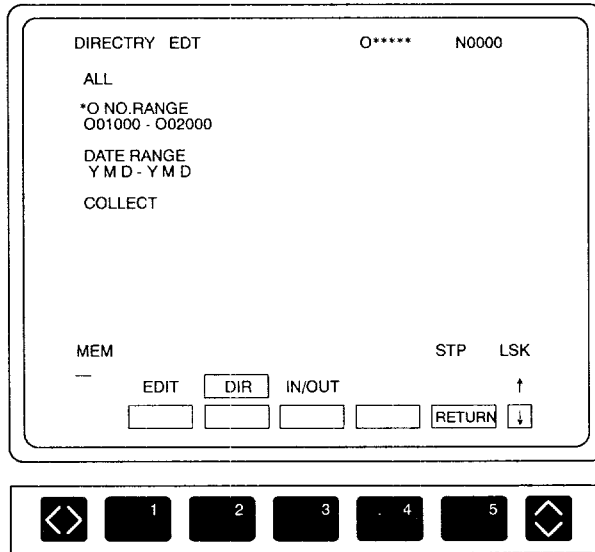
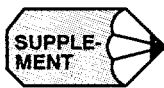

Fig. 4.27 Selection of "O NO. RANGE"



If there is an error in the input program numbers, the warning message "TOO LARGE AREA!" is displayed.

(3) Selection of Program Creation Date Range

The directory of program numbers in the specified range of program creation date is displayed.

- ① Move the selection symbol to “DATE RANGE” by pressing the cursor up/down keys after pressing the [SELECT] (f1) function soft-key. In the initial state, “ALL” is selected.
- ② Enter the first date of program creation (for example, “1991. 1. 1”) and press the [WR] key. If only the year is entered, the first day of the year is set. And if only the year and month are entered, the first day of that month of the year is set.
- ③ Enter the last date of program creation (for example, “1991.5.20”) and press the [WR] key. If only the year is entered, the last day of the year is set. And if only the year and month are entered, the last day of that month of the year is set.
- ④ Press the [RETURN] (f5) function soft-key. The screen returns to the directory display screen and displays the directory of program numbers in the range from the first program creation date to the last program creation date.

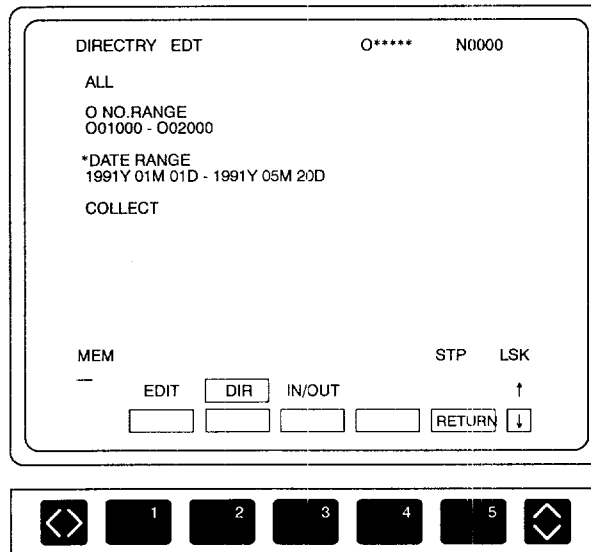

Fig. 4.28 Selection of “DATE RANGE”



If there is an error in the input program creation dates, the warning message “TOO LARGE AREA!” is displayed.

(4) Selection of Related Programs

By specifying the main program numbers, the directory of part programs that are called from the specified main program is displayed.

- ① Move the selection symbol to “COLLECT” by pressing the cursor up/down keys after pressing the [SELECT] (f1) function soft-key. In the initial state, “ALL” is selected.
- ② Enter the main program number (for example, “O12345”) and press the [WR] key.
- ③ Press the [RETURN] (f5) function soft-key. The screen returns to the directory display screen and displays the directory of program numbers of the programs called from the specified main program.

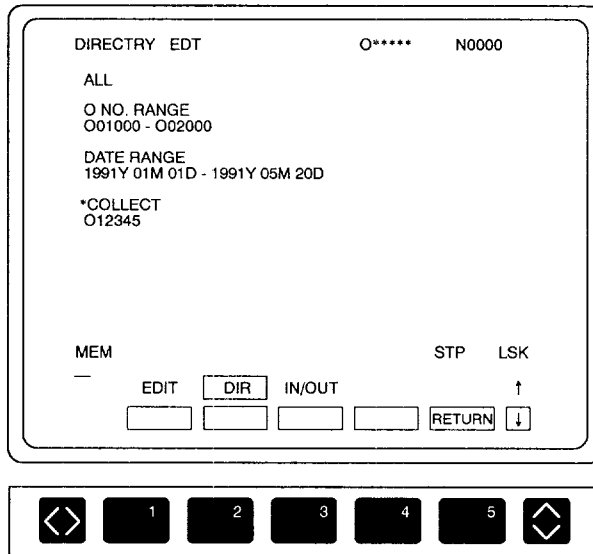
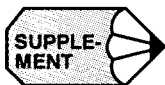

Fig. 4.29 Selection of “COLLECT”



1. For the display of the directory of related programs, only the display mode of “without comment and date” is selectable. The [DSP.SL] (f5) function soft-key is valid.
2. The programs which are called from the specified main program, but not stored in the part program memory, are displayed in blinking characters.

4.2.2 Calling a Part Program

In the directory of program numbers, part programs can be called to the program edit screen by a simple operation. When the program number of a stored program is entered, the screen changes to the program edit screen and the called program can be edited immediately. If a new program number is entered, comment must be entered to create a new part program and the screen changes to the program edit screen where the newly created program can be edited.

A part program can be called in the same manner as calling a part program in the edit job. On the program directory screen, a part program can be called by pressing function soft-keys or by entering a program and pressing the [WR] key. Follow the procedure indicated below.

- ① Press the [EDIT] (f1) job soft-key.
- ② Press the [OPEN] (f1) function soft-key. Note that this operation can be omitted.
- ③ Key in the program number of the program to be called and press the [WR] key.
- ④ Key in a comment and press the [WR] key.

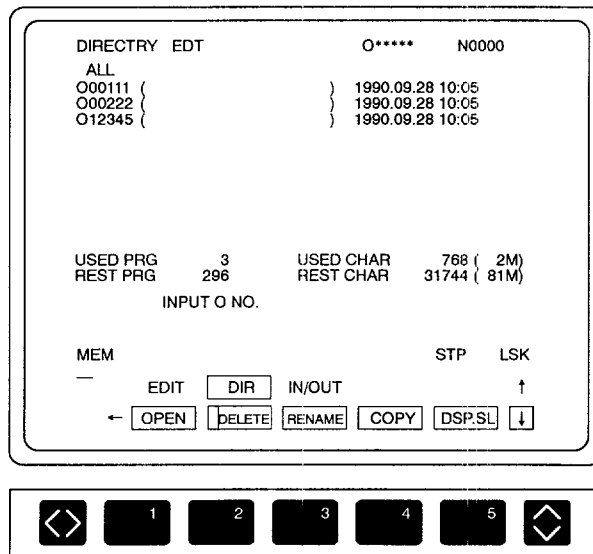
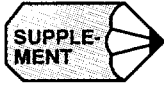

Fig. 4.30 Calling a Part Program



1. Optionally, it is possible to call a maximum of three programs at the same time by repeating steps ② to ④.
 2. In the edit lock state, it is not allowed to create a new program number. Reset the edit lock state before creating a new program number.
 3. The program presently executed can also be called. However, it is not allowed to edit such a program after calling it to the screen.
-

4.2.3 Deleting a Part Program

A part program can be deleted in a simple operation on the screen displaying the directory of part programs. The same operation as used for deleting a part program in the edit job can be used.

(1) Deleting a Part Program One by One

Part programs can be deleted one by one by selecting the [EACH] item in the pop-up menu. In the operation to delete part programs one by one, the following two methods are available: To use the [DELETE] (f2) function soft-key and to use the [ERASE] key after inputting a program number.

(a) To press the [DELETE] key

- ① Press the [DELETE] (f2) function soft-key. The message “INPUT DEL O NO.” is displayed.
- ② Enter the program number of the program to be deleted. The message “DELETE OK? (Y/N)” is displayed.
 - Enter “Y” to delete the specified program. After the completion of deletion, “DELETE COMPLETE” message is displayed.
 - Enter “N” when the program should not be deleted.

(b) To input a program number

- ① Enter the program number of the program to be deleted.
- ② Press the [ERASE] key.
- ③ The message “DELETE OK? (Y/N)” is displayed.
 - Enter “Y” to delete the specified program. After the completion of deletion, “DELETE COMPLETE” message is displayed.
 - Enter “N” when the program should not be deleted.



If the specified program number is not found, the “NOT FOUND O NO.!” message is displayed.

(2) Deleting All Part Programs

All part programs punched on a single tape can be deleted by selecting the [ALL] item in the pop-up menu.

Follow the procedure indicated below.

- ① Press the [DELETE] (f4) function soft-key.
- ② Press the [DELETE] (f4) function soft-key once again.
The pop-up menu is displayed.
- ③ Press the cursor down key to select "ALL".
- ④ Press the [WR] key. The pop-up menu for the delete menu selection is cleared.
The message "DELETE ALL? (Y/N)" is displayed.
 - Enter "Y" to delete all part programs. The "DELETE COMPLETE" message is displayed when all programs are deleted.
 - Enter "N" when the part programs should not be deleted.

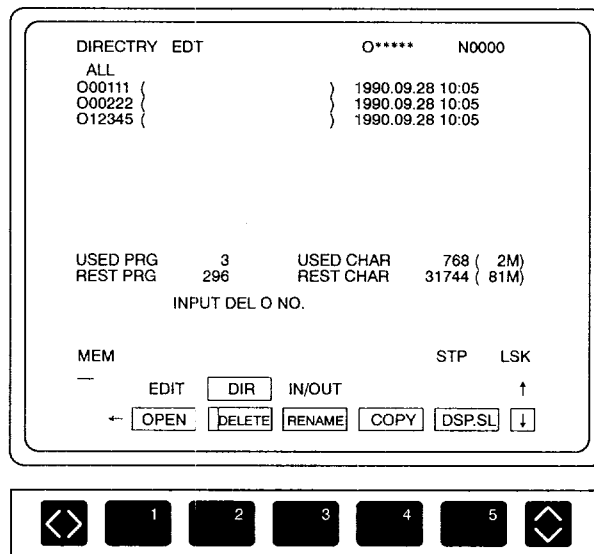
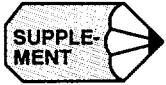

Fig. 4.31 Deleting Part Programs



1. In the edit lock state, part program deletion is not allowed. To delete a part program, cancel the edit lock state.
2. During operation, the part program presently executed cannot be deleted. To delete the program being executed, delete it only after completing operation.

4.2.4 Renaming a Part Program

The rename function changes the program number. Follow the procedure indicated below.

- ① Press the [RENAME] (f3) function soft-key. The message “INPUT OLD O NO.” is displayed.

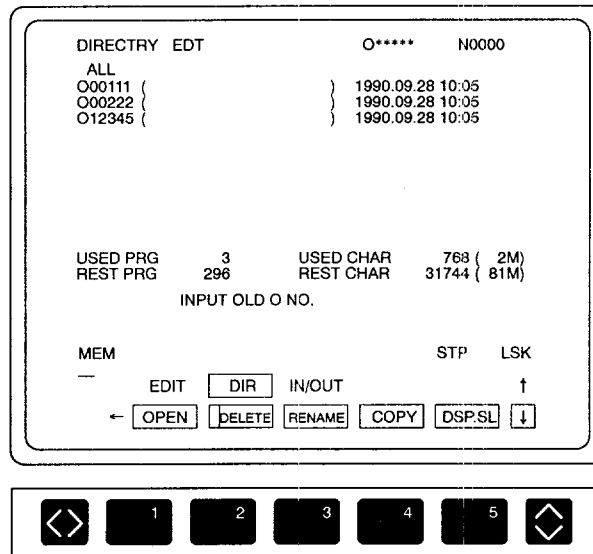

Fig. 4.32 Renaming a Part Program

- ② Enter the old program number (for example, “O100”) and press the [WR] key. The message “INPUT NEW O NO.” is displayed.
- ③ Enter a new program number (for example, “O200”) and press the [WR] key. The message “RENAME OK? (Y/N)” is displayed.
 - Enter “Y” to rename the program.
 - Enter “N” when the program should not be renamed.

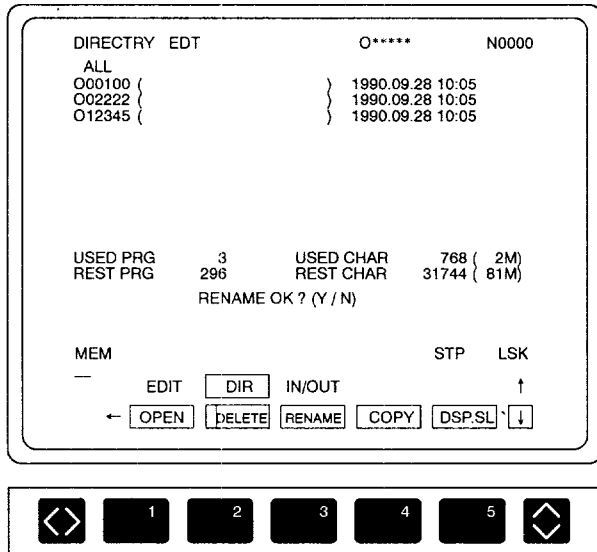

Fig. 4.33 Part Program Rename Screen

If a program number is entered at the beginning of the part program after renaming or copying (refer to 4.2.5.) a part program, whether or not this program number should also be changed automatically can be selected by the setting for the parameter.

Parameter	Selection of Processing	Remark
pm3005 D4 = 0	Do not edit the program number automatically in renaming, copying or storing.	The program creation date is not updated by program renaming operation.
pm3005 D4 = 1	Edit the program number automatically in renaming, copying or storing.	

4.2.5 Copying a Part Program

A part program is copied. The new program created by copying is assigned a new program creation date.

- ① Press the [COPY] (f4) function soft-key. The message “INPUT ORIGINAL O NO.” is displayed.
- ② Enter the original program number (for example, “O100”) and press the [WR] key. The message “INPUT O NO. (COPY)” is displayed.
- ③ Enter a new program number of the program to be created (for example, “O200”) and press the [WR] key. The message “COPY OK? (Y/N)” is displayed.
 - Enter “Y” to copy the part program.
 - Enter “N” when the part program should not be copied.

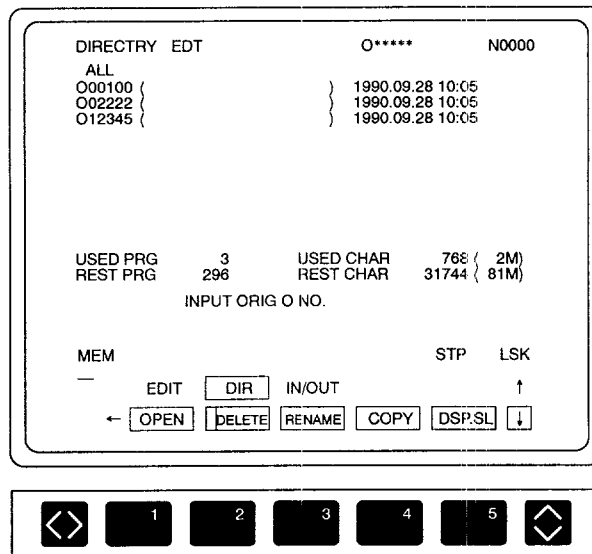

Fig. 4.34 Copying a Part Program

4.3 PART PROGRAM INPUT/OUTPUT AND VERIFY JOB

Press the [IN/OUT] (f3) job soft-key. This job provides the following functions.

- Inputting part programs
- Outputting part programs
- Verifying part programs
- Setting communication conditions
- Others

In the edit lock state, part program input, output, and verify functions cannot be executed. To execute these functions, cancel the edit lock.

4.3.1 Inputting a Part Program

Inputs a part program from an external device to the NC memory. For the input function, two menu items (EACH, ALL) are displayed in the pop-up menu. Check the communication parameters by pressing the [RS232C] (f3) function soft-key.

(1) Selection of EACH

Select “EACH” in the input pop-up menu and input part programs one by one. Follow the procedure indicated below.

- ① Enter the program number of the part program to be input (for example, “O111”) and press the [WR] key. Program input is started and the program input screen is displayed.
 - To stop the input of a program, press the [RESET] (f3) function soft-key or the [RESET] key.
 - If a program number is punched on the tape, it is not necessary to input a program number on the screen. In this case, simply press the [WR] key.
 - Even if a program number is punched on the tape, the program can be input with a new program number by entering a new program number. When a program is input to the NC memory with a new program number, whether the program number should also be changed or not can be selected by the setting for the parameter.

Parameter	Selection of Processing	Remark
pm3005 D4 = 0	Do not edit the program number automatically in renaming, copying or storing.	The program creation date is not updated by program renaming operation.
pm3005 D4 = 1	Edit the program number automatically in renaming, copying or storing.	

- If the input program number already exists, the processing to be executed can be determined by the setting for the parameter. Selection is possible from the generation of warning or the deletion of the existing program.

pm3005 D0 = 0	Warning message is displayed.
pm3005 D0 = 1	Program number is deleted.

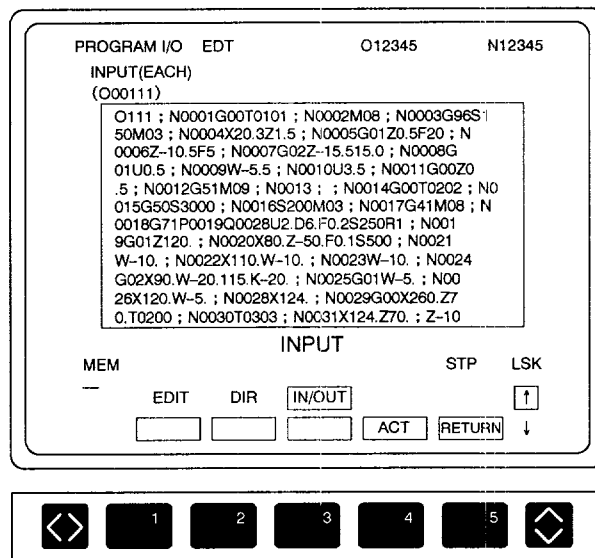

4

Fig. 4.35 Part Program Input Screen

- Whether or not the list of part programs being input is displayed on the screen can be selected by the setting for the parameter setting.

Parameter	Selection of Processing
pm0007 D5 = 0	List of programs is not displayed.
pm0007 D5 = 1	List of programs is displayed.

Table 4.1 Difference between the [RESET] (f3) Function Soft-key and the [RESET] Key

[RESET] (f3) key	Stops only tape input/output and verifies. Operation is not influenced.
[RESET] key	Resets all NC operations.

-
- ② When an end M code (M02, M30, M99) or the “%” code is read, program input is completed. Upon completion of program input, the message “INPUT COMPLETE” is displayed.
- The [RETURN] (f5) function soft-key is invalid until the program input is completed. However, the process keys are valid.
 - Whether or not the end M code is regarded as the end of a program can be selected by the parameter setting.

pm3005 D3 = 0	The end M code (M02, M30, M99) is not regarded as the end of a program.
pm3005 D3 = 1	The end M code (M02, M30, M99) is regarded as the end of a program.

- Whether or not spaces are deleted during program input and verified can be selected by the setting for the parameter.

pm0020 D0 = 0	Spaces are deleted.
pm0020 D0 = 1	Spaces are not deleted.

4

(2) Selection of "All"

Select "ALL" in the input pop-up menu and input all part programs punched on tape at a time. Follow the procedure indicated below.

- ① When "ALL" is selected, the message "ALL PROG. INPUT" is displayed and the message "INPUT OK ? (Y/N)" is displayed.
 - To input all programs, enter "Y". Program input starts and the screen changes. As shown in Fig. 4.35, the list of programs being input is displayed.
 - Enter "N" when part programs should not be input.
 - To stop the input of a program, press the [RESET] (f3) function soft-key or the [RESET] key.

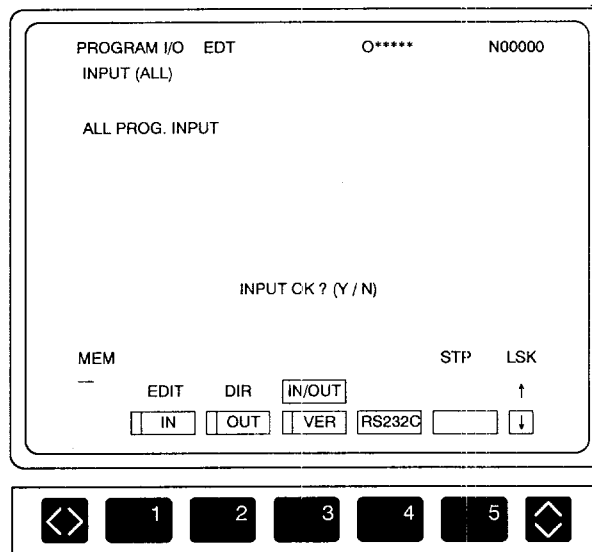

Fig. 4.36 All Program Input Screen

- ② The ALL input operation is completed when the % code is input. Upon completion of the input of the part programs, the message "INPUT COMPLETE" is displayed.

4.3.2 Outputting a Part Program

Outputs a part program from the NC memory to an external device.

The output function provides the following six menu items (EACH, PLR, RANG, ALL, COL, and DATE) by the pop-up menu. Check the communication parameters by pressing the [RS232C] (f3) function soft-key.

(1) Selection of EACH

Select “EACH” in the output pop-up menu and output part programs one by one. Follow the procedure indicated below.

- ① Enter the program number of the program to be output (for example, “O2111”) and press the [WR] key. Output of the specified program starts and the list of the program being output is displayed on the screen.
- To stop program output, press the [RESET] (f3) function soft-key or the [RESET] key.

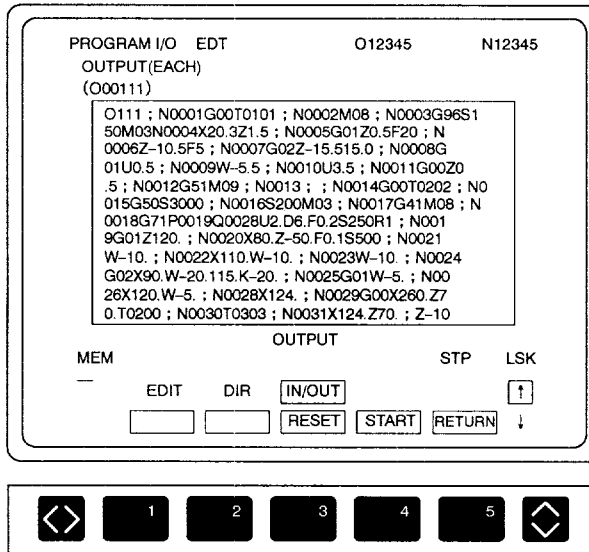

Fig. 4.37 Program Output Screen (EACH)

- Whether or not the list of part programs being output is displayed can be selected by the parameter setting.

pm0007 D5 = 0	Program list is not displayed.
pm0007 D5 = 1	Program list is displayed.

- To cancel the feed portion at the leader and trailer part, press the [CAN] key while feed holes are being output.
- ② Upon completion of the program output, the message “OUTPUT COMPLETE” is displayed. The [RETURN] (f5) function soft-key is not valid until output of a program is completed. Note that process keys are valid.

(2) Selection of PLR., RANG, ALL, COL and DATE

Select the required output function from the output pop-up menu. Follow the procedure indicated below.

- ① Press the [OUT] (f2) function soft-key. The “OUTPUT (EACH)” screen is displayed.
- ② Press the [OUT] (f2) function soft-key once again. The pop-up menu appears, displaying the selection items of EACH, PLR., RANG, ALL, COL, and DATE.

4

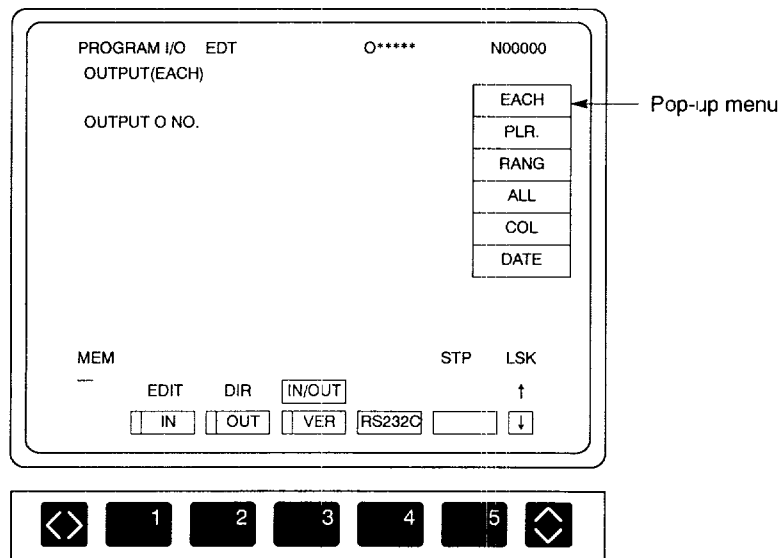

Fig. 4.38 Output Menu Selection Screen

- ③ Select the menu item by moving the cursor with the cursor up/down keys and press the [WR] key. The output pop-up menu is cleared and the specified screen is displayed.

(a) Selection of PLR.

Outputs the specified multiple part programs. Follow the procedure indicated below.

- ① Enter the program number of the part program to be output (for example, "O111") and press the [WR] key.
- ② Move the cursor to the next line and press the [WR] key. Up to 20 program numbers can be entered consecutively.

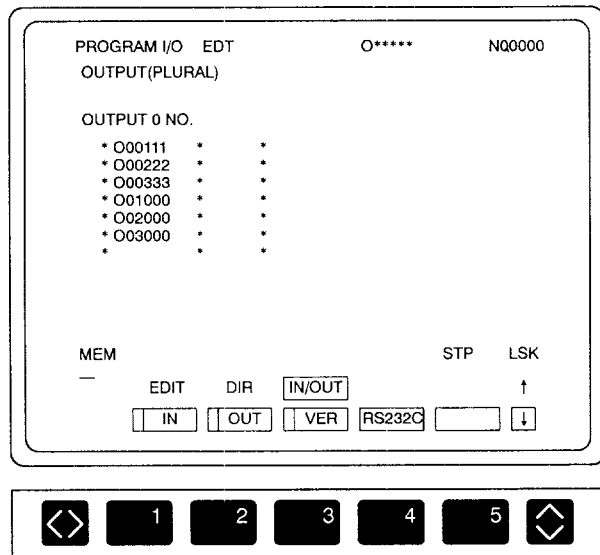

Fig. 4.39 Program Number Input Screen

- ③ Output of the specified program starts and the list of the program being output is displayed on the screen. The specified programs are output on a single NC tape.

(b) Selection of RANG

Outputs the part programs in the range specified by the program numbers. Follow the procedure indicated below.

- ① The message is displayed requesting the input of the start program number of the range. Key in the first program of the program output range (for example, "O111") and press the [WR] key.
- ② For the next message, input the end program number of the range (for example, "O222") and press the [WR] key.

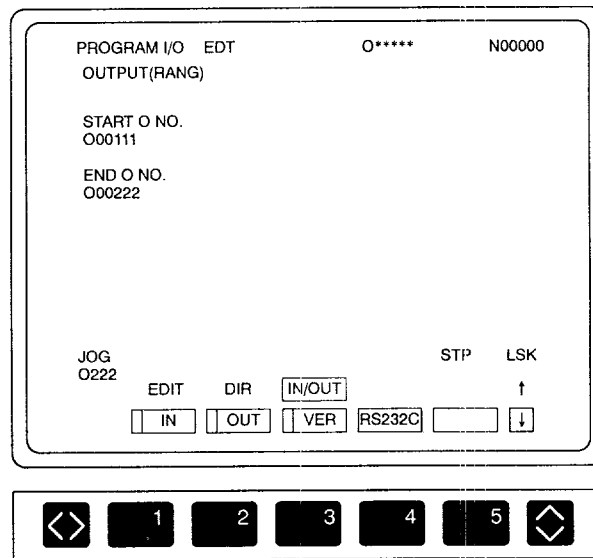

4

Fig. 4.40 Start and End Program Number Input Screen

- ③ Output of the specified program start and the list of the programs being output is displayed on the screen. The part programs in the specified range are output on a single NC tape. If no program number is found in the specified range, the warning message "O NO NOT FOUND!" is displayed.

(c) Selection of ALL

Outputs all part programs stored in the NC memory. Follow the procedure indicated below.

- ① The message “ALL PROG. OUTPUT” is displayed on the screen and the message “OUTPUT OK? (Y/N)” is displayed.
 - Enter “Y” to output all part programs.
 - Enter “N” when the part programs should not be output.

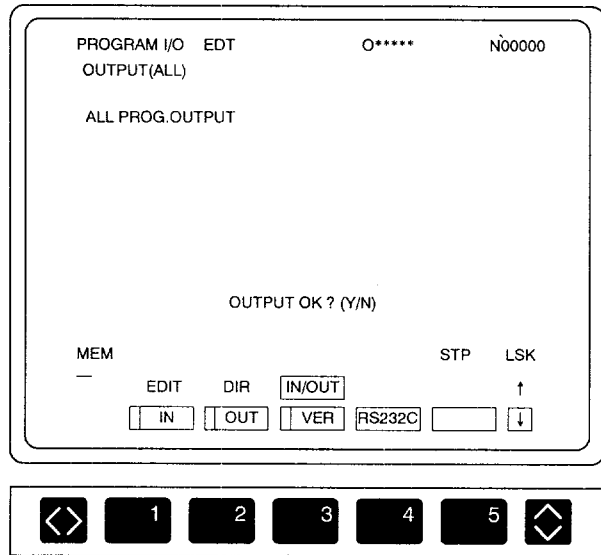

Fig. 4.41 All Part Program Output Screen

- ② Output of the part programs starts and the list of the program being output is displayed on the screen. All part programs are output on a single NC tape.

(d) Selection of COL.

By specifying the main program, the subprograms, program copies, and macroprograms called from the specified main program can be output up to 500 programs. Follow the procedure indicated below.

- ① When the "COL." item is selected, the "COLLECT O NO." message is displayed; enter the main program number (for example, "O12345") and press the [WR] key.

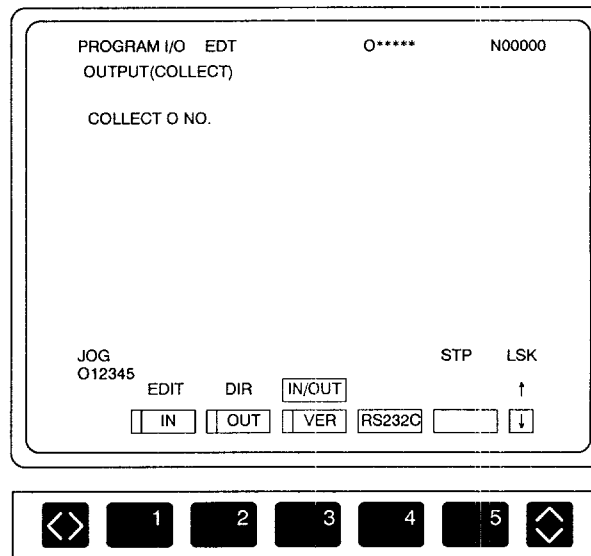

4

Fig. 4.42 Program Number Input Screen

- ② Output of the programs starts and the list of the programs being output is displayed on the screen. The main program and the programs that are called from the specified main program are output on a single NC tape.

(e) Selection of DATE

The date of part program creation and registration is stored in the NC memory. It is possible to output part programs by specifying the date. Follow the procedure indicated below.

- ① The message requesting the input of the date is displayed. Enter the date of program creation of the programs to be output (for example, “1991. 05. 20”) and press the [WR] key. If only the year is entered, all programs created in the specified year are output, and if only the year and the month are entered, all programs created in the specified month of the specified year are output.

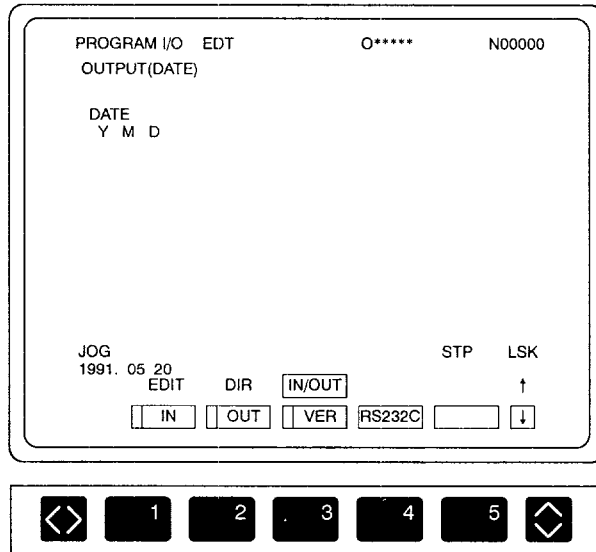

Fig. 4.43 Date Input Screen

- ② Output of the specified programs starts and the list of the programs being output is displayed on the screen. The part programs created in the specified date are output on a single NC tape.

4.3.3 Verifying the Part Programs

Compares the part program in an external device with the part program stored in the NC memory. For the execution of the verify function, selection is possible from each and all using the pop-up menu.

Check the setting for communication parameters by pressing the [RS232C] (f5) function soft-key.

(1) Selection of EACH

Verifies part program one by one, by selecting the [EACH] item in the pop-up menu. Follow the procedure indicated below.

- ① Press the [VER] (f3) function soft-key.
- ② Press the [VER] (f3) function soft-key once again. The pop-up menu is displayed to allow the selection between “EACH” and “ALL”.
- ③ Select “EACH” by moving the cursor with the cursor up/down keys.

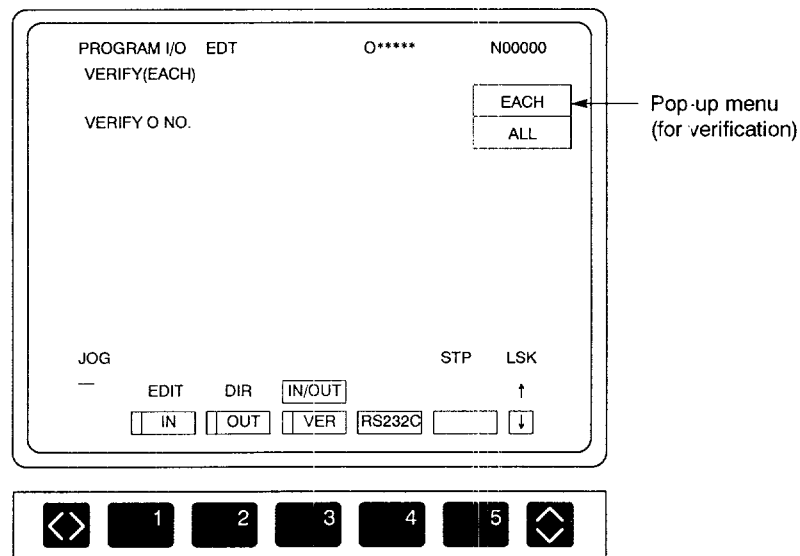

Fig. 4.44 Verification Menu Selection Screen

- ④ Enter the program number of the program to be verified (for example, “O111”) and press the [WR] key.

- ⑤ Verification is started and the list of the part programs (tape input side) to be compared with the part programs stored in the NC memory is displayed on the screen.



Fig. 4.45 Program Verify Screen

- It is possible to select whether or not the list of part programs should be displayed on the screen for execution part program verification.

pm0007 D5 = 0	List of part programs is not displayed.
pm0007 D5 = 1	List of part programs is displayed.

- If inconsistency between the contents of the part programs stored in the NC memory and the contents of the one input from an external device is found, the display area in the screen is divided into two parts. The upper half area displays the list of the part programs in the NC memory and the lower half area displays the list of the part programs input from the external device. Inconsistent parts are highlighted.

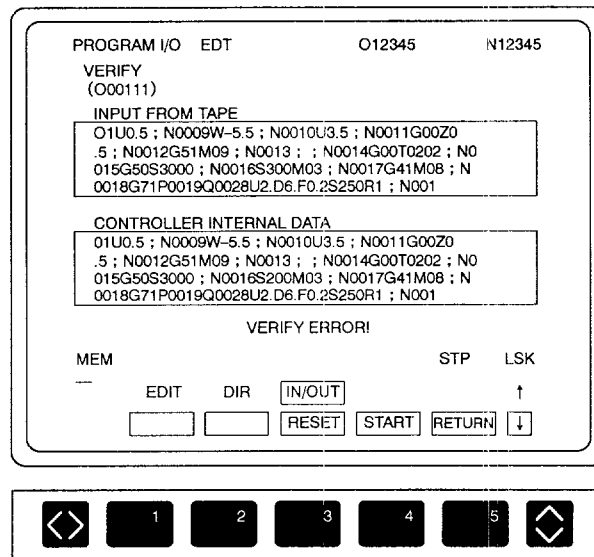

Fig. 4.46 Screen after Occurrence of Inconsistency

(2) Selection of ALL

Verifies all programs punched on tape, by selecting the [ALL] item in the pop-up menu. Follow the procedure indicated below.

- ① Press the [VER] (f3) function soft-key.
- ② Press the [VER] (f3) function soft-key once again. The pop-up menu is displayed to allow the selection between “EACH” and “ALL” (Fig. 4.46).
- ③ Select “ALL” by moving the cursor with the cursor up/down keys and press the [WR] key.
- ④ The pop-up menu is cleared and the VERIFY (ALL) screen is displayed.

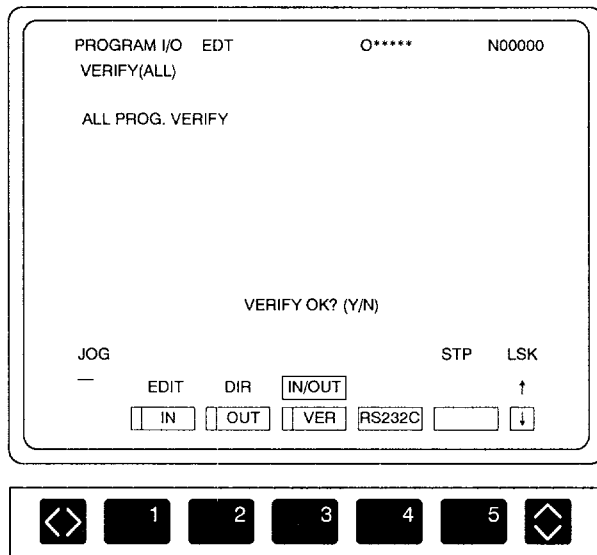

Fig. 4.47 All Program Verify Screen

- ⑤ The “ALL PROG. VERIFY” message is displayed, and the message “VERIFY OK? (Y/N)” is displayed.
 - Enter “Y” to execute all program verify operation.
 - Enter “N” when program verification should not be executed.
- ⑥ Verification is started and the list of the part programs (input from the tape) to be compared with the part programs stored in the NC memory is displayed on the screen.
 - If inconsistency is found between the contents of the part programs stored in the NC memory and the contents of the one input from an external device, the screen changes as shown in Fig. 4.47 and inconsistent parts are highlighted.

4.3.4 Setting the Communication Conditions

Sets the baud rate of the data I/O interface, stop bit length, the use of control codes, etc.

(1) Setting the RS-232C Communications Parameters

This screen is used to display and set the communication parameters used when an external device is connected by the RS-232C interface. For the connection of an external device, two ports are provided; one is used for input and the other for output. Follow the procedure indicated below.

- ① Press the [RS232C] (f4) function soft-key, and the screen as shown below is displayed.

PROGRAM I/O	EDT	O*****	N00000
I/O UNIT SET		IN	OUT
UNIT		RS232C	RS232C
PORT		NO.1	NO.2
BPS		4800	9600
STOP BIT		2BIT	1BIT
BITS		8BITS	7BITS
PARITY		OFF	EVEN
X ON/OFF		ON	OFF
RTS CONTROL		ON	OFF
DR CNTRL		ON	OFF
NC CNTRL		ON	OFF

MEM		STP	LSK
---	EDIT	DIR	IN/OUT
	1200	2400	4800
		9600	SELECT
			↑
			↓

◀	1	2	3	4	5	▶
---	---	---	---	---	---	---

4

Fig. 4.48 RS-232C Communication Parameters Setting

- ② Move the cursor to the parameter for which the data should be set by using the cursor up/down keys. When the cursor is moved to a certain parameter, the contents of the function soft-keys change meeting the selected parameter.
- ③ Press the soft-key corresponding to the required setting. The selected value is set for the cursor located parameter. For example, in the setting of BORS, if [9600] (f4) soft-key is pressed, "9600" is written.



For the parameters for which "*****" is displayed, setting is not permitted.

For the serial interface, setting is possible as indicated in Table 4.2.

Table 4.2 Serial Interface Setting

Menu Item	Input	Output
UNIT (device)	YE tape reader	
	General-purpose RS-232C	General-purpose RS-232C
PORT	NO. 1	NO. 1
	NO. 2	NO. 2
BORS (baud rate)	100 or 75	100 or 75
	110 or 150	110 or 150
	300	300
	600	600
	1200	1200
	2400	2400
	4800	4800
	9600	9600
STOP BIT	1 bit	1 bit
	2 bits	2 bits
BITS (bit length)	7 bits	7 bits
	8 bits	8 bits
PARITY (parity scheme)	Even parity	Even parity
	Odd parity	Odd parity
	None	None
X ON/OFF (control code)	Supported	Supported
	None	None
RTS CONTROL	Supported	Supported
	None	None
PARITY ISO	Supported	Supported
	None	None

Note 1: Although two RS-232C ports are provided, these two ports cannot be used at the same time. For these two ports, setting can be made independently from each other.

2: Recommended setting for the communication at 9600 bps is indicated below.

BORS	9600 bps	PARITY	EVEN/ODD/OFF
STOP BIT	2 BITS	NC DATA SPECIAL CONTROL	OFF
BIT LENGTH	8 BITS		

The menu items are explained below.

(a) UNIT (external device)

Select "YE tape reader" when the tape reader special for YASNAC is used. If "YE tape reader" is set, parameters are automatically set and "****" is displayed for other parameters.

BORS	4800 bps
STOP BIT	2 BITS
BIT LENGTH	8 BITS
PARITY	OFF
X ON/OFF	ON

By selecting "RS232C" (general-purpose RS-232C), connection is possible with a variety of RS-232C devices by setting appropriate communication parameters.

4

(b) PORT

Selection is possible between No. 1 port and No. 2 port.

(c) BORS

Communication speed can be set by this parameter. Whether 100 and 110 bps or 75 and 150 bps are selected for low speed is determined by the setting for the following parameters.

No. 1 port	Input	pm0011 D7 = 0	100 and 110 bps
		pm0011 D7 = 1	75 and 150 bps
	Output	pm0013 D7 = 0	100 and 110 bps
		pm0013 D7 = 1	75 and 150 bps
No. 2 port	Input	pm0016 D7 = 0	100 and 110 bps
		pm0016 D7 = 1	75 and 150 bps
	Output	pm0018 D7 = 0	100 and 110 bps
		pm0018 D7 = 1	75 and 150 bps

(d) STOP BIT

It is possible to set the bit length of the stop bit.

(e) BITS

It is possible to set the bit length of the data.

(f) PARITY

It is possible to specify the hardware dependent parity check status.

(g) X ON/OFF

It is possible to specify whether or not the control codes are used.

(h) RTS CONTROL

When the setting for this parameter is “ON”, communication between the YASNAC and the connected device is controlled using the RS and CS signals. To use the RTS control, the cross-cable as shown below must be used.

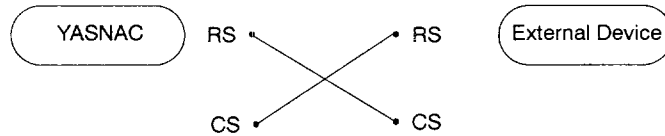

(i) PARITY ISO

When ISO code data is used, this parameter is used to set whether parity check is made with the higher data bits. For this parameter, setting is possible if “YE tape reader” is selected for UNIT.

(2) Other Communication Control Parameters

Set the communication parameters used for data communications with an external device.

(a) DR LINE CHECK

The DR line check executes the test at the NC side whether the DR line of the connected external device is ON (that is, whether the connected device is ready for communications). For this function, the following parameters are provided. To perform this test, use the cable that connects the DR line of the NC to the DR line of the connected device. The connected device must have the DR line control function.

No. 1 port	Input	pm0012 D2 = 1
	Output	pm0014 D2 = 1
No. 2 port	Input	pm0017 D2 = 1
	Output	pm0019 D2 = 1

4

(b) NC DATA SPECIAL CONTROL

This parameter is used to set whether or not the check specific to the NC is executed and also whether or not special character codes are used. How this control is used is indicated below.

Control ON for input	<p>The following are as set with parameters:</p> <ul style="list-style-type: none"> • pm0004: D1, D2, D3 • pm3005: D0, D2, D3, D4, and D5 <p>The following parameters are made valid:</p> <ul style="list-style-type: none"> • pm4100 - 4109 and pm4144 - 4146 <p>EIA/ISO automatic recognition is provided.</p>
Control OFF for input	<p>Several bits of the following parameters are fixed:</p> <ul style="list-style-type: none"> • pm0004: $\times \times \times \times 100 \times$ • pm3005: $\times \times 0000 \times 0$ <p>The following parameters are made invalid:</p> <ul style="list-style-type: none"> • pm4100 - 4109 and pm4144 - 4146 <p>Fixed to ISO code</p>
Control ON for output	<p>The following are as set with parameters:</p> <ul style="list-style-type: none"> • pm0004: Other than D3 • pm3005: D5 <p>The following parameters are made valid:</p> <ul style="list-style-type: none"> • pm4100 - 4109 and pm4144 - 4146
Control OFF for output	<p>Several bits of the following parameters are fixed:</p> <ul style="list-style-type: none"> • pm0004: $0110 \times \times \times 0$ • pm3005: $\times \times 0 \times \times \times \times \times$

4.3.5 Other Function

With the [RESET] (f3) function soft-key, resetting operation is possible. The processing which is reset by the reset operation can be executed again by pressing the [START] (f4) function soft-key.

(1) Reset

The [RESET] function soft-key provides the background reset function which is different from the function provided by the [RESET] key on the operation panel. The reset function executes the following processing.

- Interruption of input/output/verify operation
- Turning on the label skip function
- Resetting the background alarm (ALM 9000's)

Even if the [RESET] (f3) function soft-key is pressed, the "RST" status indicating message is not displayed.

(2) Execution

If the NC is reset during input, output, or verify processing, the reset processing can be executed again by pressing the [START] (f4) function soft-key.

5

SETUP PROCESS OPERATION

Chapter 5 describes the operation carried out by using the set process key. In the set process, setting up before starting machining is carried out by using the workpiece coordinate system job, tool data job, and tool life control job.

Job selection is possible by using either the job soft-keys or the [SET] process selection key.

The operation indicated above can be executed any time independent of the NC operation mode even while automatic operation is being executed.

5

5.1	SETUP JOB	5 - 2
5.1.1	Writing the Tool Offset Data	5 - 2
5.1.2	Clearing the Offset Data	5 - 4
5.2	WORKPIECE COORDINATE SYSTEM MANAGEMENT	5 - 5
5.2.1	Writing the Workpiece Coordinate System Shift Amount	5 - 5
5.2.2	Clearing the Workpiece Coordinate System Shift Amount	5 - 6
5.3	TOOL LIFE CONTROL JOB	5 - 7
5.3.1	Writing the Tool Life Control Data	5 - 7
5.3.2	Displaying the Tool Life Control Data	5 - 7
5.3.3	Setting the Tool Life Control Data	5 - 8
5.3.4	Erasing the Tool Life Control Data	5 - 10

5.1 SETUP JOB

When the [SET] job key is pressed, the [OFFSET] (f1) function soft-key is displayed. The offset function is used to write and clear the tool offset data.

5.1.1 Writing the Tool Offset Data

The offset data include the X-axis tool offset, Z-axis tool offset, nose R offset and control point. In the standard specification, 16 sets of tool offset data are provided. Optionally, the number of tool offset data sets can be expanded to 99 or 299. Follow the procedure indicated below to write the tool offset data.

- ① Move the cursor to the offset number for which the offset data should be set by using the cursor up/down keys. It is also possible to set the offset number by pressing the [WR] key after entering the required offset number (01, for example).

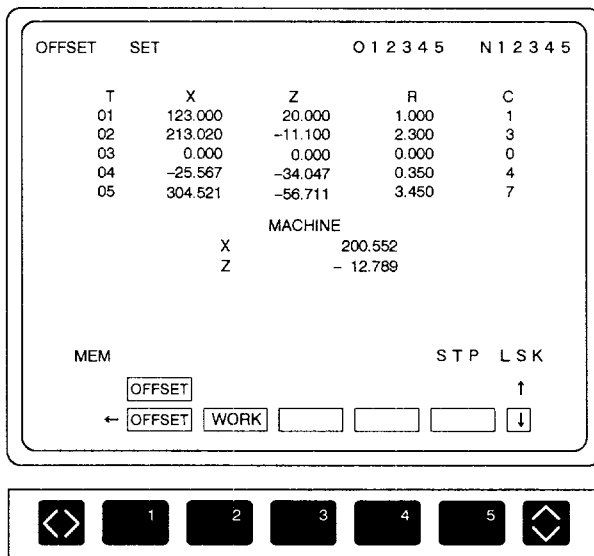

Fig. 5.1 Offset Screen (2-axis Specification)

- ② The cursor moves to the specified offset number and five sets of the tool offset data (tool offset data, nose R offset data, and control point) are displayed including the tool offset data of the specified offset number.
- ③ Enter the numerical value following the address of the data to be set.

Table 5.1

To set the X-axis offset data	<ul style="list-style-type: none">• In absolute value input, press [WR] after entering the value such as X123.000.• In incremental value input, press [WR] after entering the value such as U123.000.
To set the Z-axis offset data	<ul style="list-style-type: none">• In absolute value input, the address to be specified is "Z".• In incremental value input, the address to be specified is "W".
To set the nose R offset data	<ul style="list-style-type: none">• Press [WR] after entering "R0.5".
To set the control point	<ul style="list-style-type: none">• Press [WR] after entering "C3".



1. For the entry of nose R offset data (R) and control point (C), incremental input is not possible.
2. For the 3-axis specification, display of MACHINE POSITION is not provided.

5.1.2 Clearing the Offset Data

Follow the procedure indicated below to clear the offset data.

- ① After pressing the [OFFSET] (f1) function soft-key, move the cursor to the offset number of the offset data to be cleared.
- ② Press the [0 CLR] (f1) function soft-key to clear the offset data of the offset number on which the cursor is positioned to zero.
- ③ Press the [ALL CLR] (f2) function soft-key, and the message “CLEAR ALL OFFSET?” is displayed.

Press “Y” to clear the entire offset memory of the offset number.

The screenshot displays the Offset Screen with the following data:

OFFSET	SET	O	1	2	3	4	5	N	1	2	3	4	5
T	X	Z	R	C									
01	123.000	20.000	1.000	1									
02	213.020	-11.100	2.300	3									
03	0.000	0.000	0.000	0									
04	-25.567	-34.047	0.350	4									
05	304.521	-56.711	3.450	7									

MACHINE
X 200.552
Z - 12.788

CLEAR ALL OFFSET? (Y / N)

MEM S T P L S K
↑
← [0 CLR] [ALL CLR] [] [] [] [] ↓

Fig. 5.2 Offset Screen (when [ALL CLR] (f2) is pressed)

5.2 WORKPIECE COORDINATE SYSTEM SHIFT JOB

Workpiece coordinate system shift data can be set using the workpiece coordinate system shift job. The workpiece coordinate system shift data are stored to offset number T00 and the amount set here is valid for all cutting tools when a workpiece coordinate system is set.

5.2.1 Writing the Workpiece Coordinate System Shift Amount

Follow the procedure indicated below to write the workpiece coordinate system shift amount data.

- ① Press the [WORK] (f2) function soft-key.
- ② Enter a numerical value following an address. The address to be specified differs depending on which of the absolute or incremental inputs is used.

Table 5.2

To set the X-axis shift data	Absolute input	Press [WR] after entering the shift amount such as X12.345.
	Incremental input	Press [WR] after entering the shift amount such as U12.345.
To set the Z-axis shift data	Absolute input	The address to be specified is "Z".
	Incremental input	The address to be specified is "W".
To set the C-axis shift data	Absolute input	The address to be specified is "C".
	Incremental input	The address to be specified is "H".

5

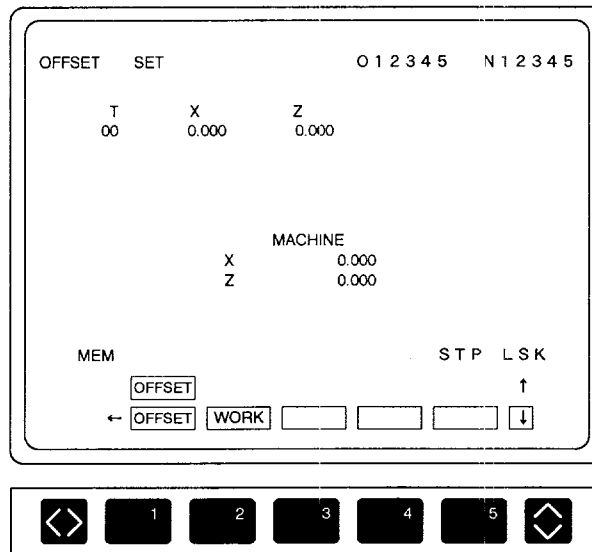

Fig. 5.3 Workpiece Shift Screen (2-axis Specification)

5.2.2 Clearing the Workpiece Coordinate System Shift Amount

Follow the procedure indicated below to clear the workpiece coordinate system shift data.

- ① Press the [WORK] (f2) function soft-key.
- ② Press the [0 CLR] (f1) function soft-key, and the workpiece coordinate system shift amount is cleared to zero.

5.3 TOOL LIFE CONTROL JOB

When the tool life control function is used, tools are controlled in the following manner.

In a program, the tools are specified by the tool group; when tool life has expired, the next tool in the same group is selected.

5.3.1 Writing the Tool Life Control Data

Classify tools into groups according to the type of tools and set the tool life for the individual groups.

5.3.2 Displaying the Tool Life Control Data

When the [TOOL] soft-key is pressed in the [SET] process, the screen as shown in Fig. 5.4 is displayed. The TOOL LIFE screen display first is the screen for group 00. The TOOL LIFE screen consists of multiple pages; one page for one tool group. One page displays the tool data (max. 10 tools) in one group. To display the TOOL LIFE screen of the desired tool group number, either press the page keys, or press the cursor up/down keys after entering the desired group number.

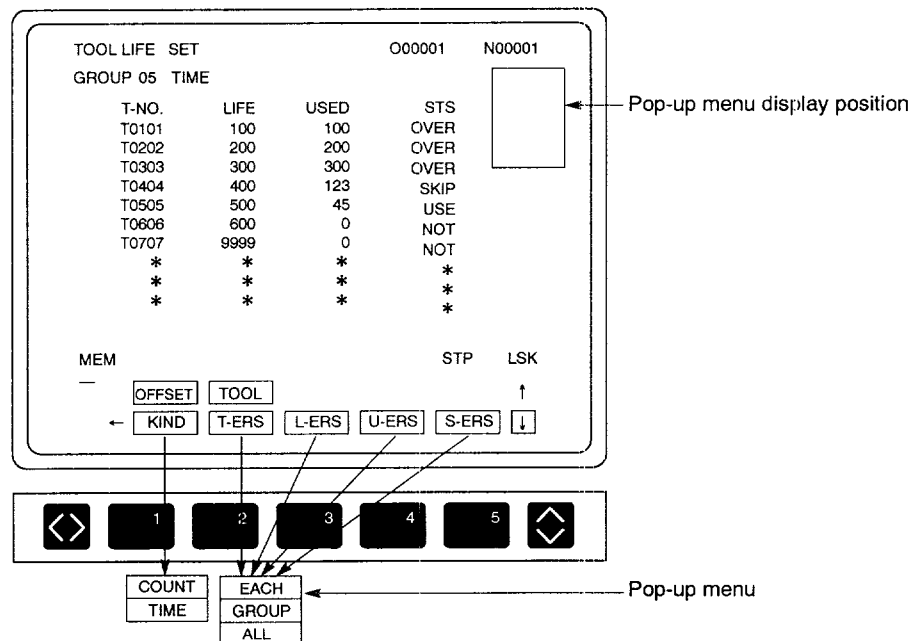

Fig. 5.4 Tool Life Control Data Display Screen

5.3.3 Setting the Tool Life Control Data

The tool life control data can be set in the following two methods: to set the data by directly keying them in using the NC operation panel keys and to set them by inputting them from tape. This sub section describes the procedure used for writing and correcting the tool life control data by using the keys on the NC operation panel. Setting of the tool life control data using tape is possible at the input screen of the IN/OUT job in the [MAINT] process. For details, refer to 8.3 “INPUT/OUTPUT AND VERIFY JOB”.

(1) Writing a Tool Number

Set the tool number for which the tool life control is executed.

Move the cursor to the T-NO. column and press the [WR] key after keying in a tool number (1 to 9998).

When a tool number is written to T-NO., the corresponding data are initialized: 9999 for LIFE, 0 for USE, and NOT for STS.

5



To register tools additionally, move the cursor to the tool number immediately before that of the tool to be added, then press the [INSRT] key after entering the tool number.



While the tool life control is executed, the tools are used in the order from the top. If an attempt is made to enter the tool number which is already entered, the warning message “REPETITION ERROR!” is displayed.

(2) Writing the Tool Life

Set the tool life.

Move the cursor to the LIFE column, key in the tool life (1 to 9999), and press the [WR] key.

- After the tool life is changed, the cursor moves to the USED column.

(3) Writing the Tool-use Data

Set the tool-use count data.

Move the cursor to the USED column, key in the use-count data (0 to 9999), and press the [WR] key.

- Enter “0” when a new tool is used. If the value in the USED column is greater than the LIFE value, the STS automatically changes to “OVER”.
- After the tool life is changed, the cursor moves to the next T_NO. column.

(4) Writing the Tool Life Control Type

- ① When the [KIND] (f1) function soft-key is pressed, the pop-up menu as indicated below is displayed and, at the same time, the message “SELECT BY CURSOR & WR” is displayed.
- ② To change the life control type, move the cursor to the required life control type by using the cursor up/down keys and press the [WR] key. When it is not necessary to change the presently selected life control type, press the [KIND] (f1) function soft-key again and the pop-up menu is cleared.

Table 5.3 Tool Life Control Type Menu

Menu	Contents
TIME	Tool life is controlled by the length of time the tool has been used.
COUNT	Tool life is controlled by the number of times the tool has been used.

- The selected tool life control type is valid only for the tool group for which it is written.

5.3.4 Erasing the Tool Life Control Data

(1) Erasing the Tool Number

- ① When the [T-ERS] (f2) function soft-key is pressed, the pop-up menu is displayed and, at the same time, the message “SELECT BY CURSOR & WR” is displayed.
- ② Select the required erase mode by moving the cursor to the required erase mode with the cursor up/down keys and press the [WR] key. When it is not necessary to change the presently selected erase mode, press the [T-ERS] (f2) function soft-key again and the pop-up menu is cleared.

Table 5.4 Tool Life Control Data Erase Menu

Menu	Contents
EACH	The data of the tool number indicated by the cursor are erased.
GROUP	The data of the tools in the displayed group are erased.
ALL	The data of all groups are erased.

- When tool data are erased for all groups or the selected group, the tool life control type of such groups is automatically set at “TIME”.
- After the execution of tool number erase operation, the data at the LIFE, USED, and STS columns are also erased and “*” is displayed.

(2) Erasing the Tool Life Set Data

- ① When the [L-ERS] (f3) function soft-key is pressed, the pop-up menu as indicated below is displayed and, at the same time, the message “SELECT BY CURSOR & WR” is displayed.
- ② Select the required erase mode by moving the cursor to the required erase mode with the cursor up/down keys and press the [WR] key. When it is not necessary to change the presently selected erase mode, press the [L-ERS] (f3) function soft-key again and the pop-up menu is cleared.

Table 5.5 Tool Use Count Data Erase Menu

Menu	Contents
EACH	The data of the tool number indicated by the cursor are erased.
GROUP	The data of the tools in the displayed group are erased.
ALL	The data of all groups are erased.

- After the execution of tool life set data erase operation, the data are cleared to zero.

(3) Erasing the Tool Used Data

- ① When the [U-ERS] (f4) function soft-key is pressed, the pop-up menu as indicated below is displayed and, at the same time, the message “SELECT BY CURSOR & WR” is displayed.
- ② Select the required erase mode by moving the cursor to the required erase mode with the cursor up/down keys and press the [WR] key. When it is not necessary to change the presently selected erase mode, press the [U-ERS] (f4) function soft-key again and the pop-up menu is cleared.

Table 5.6 Tool Use Count Data Erase Menu

Menu	Contents
EACH	The data of the tool number indicated by the cursor are erased.
GROUP	The data of the tools in the displayed group are erased.
ALL	The data of all groups are erased.

- After the execution of tool life used data erase operation, the data are cleared to zero.

(4) Erasing the Status Data

- ① When the [S-ERS] (f5) function soft-key is pressed, the pop-up menu as indicated below is displayed and, at the same time, the message “SELECT BY CURSOR & WR” is displayed.
- ② Select the required erase mode by moving the cursor to the required erase mode with the cursor up/down keys and press the [WR] key. When it is not necessary to change the presently selected erase mode, press the [R-ERS] (f4) function soft-key again and the pop-up menu is cleared.

Table 5.7 Status Data Erase Menu

Menu	Contents
EACH	The data of the tool number indicated by the cursor are erased.
GROUP	The data of the tools in the displayed group are erased.
ALL	The data of all groups are erased (blank).

- After the execution of the status data erase operation, the displayed data of the status is cleared.

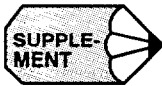

The LIFE, USE, and STS are closely related to each other.

- Generally, “OVER” is displayed if “LIFE < USE”.
- The data can be corrected when the edit lock is OFF and the NC is in the automatic operation suspended state (reset state). This also applies to the erase operation.
- For the change and erase of the LIFE, USE, and STS data, data change and erase operation are possible in the single-block stop state, with an exception of the tool data of the tool in the tool life control mode.
- When the setting of the number of groups and the number of tools (set for parameters pm0009 D6, D7) is changed, the display changes at the time the parameter is set valid (at the time the reset key is pressed.).

6

RUN PROCESS

Chapter 6 describes the operation carried out by using the run process key.

In the run process, the part program is actual executed by the program job (program run, MDI run), command value display job, setting job, and NC path drawing job.

During the execution of the part program it is possible to display the list of the program, command values of the program presently executed, and the necessary settings having been made to execute the program.

Job selection is possible by using either the job soft-keys or the [RUN] process selection key.

6

6.1	PROGRAM JOB	6 - 3
6.1.1	Program Information Displayed on Screen	6 - 3
6.1.2	Program Number Search	6 - 4
6.1.3	Address Search	6 - 6
6.1.4	Editing the Part Program Stored in Memory	6 - 7
6.1.5	Execution of a Part Program	6 - 9
6.1.6	Display of Subprogram Nesting Information	6 - 10

6.2	MDI OPERATION JOB	6 - 11
6.2.1	Entry of an MDI Program	6 - 11
6.2.2	Editing an MDI Program	6 - 11
6.2.3	Execution of an MDI Program	6 - 12
6.2.4	Deleting an MDI Program	6 - 13
6.2.5	Storing an MDI Program	6 - 13
6.3	COMMAND VALUE DISPLAY JOB	6 - 14
6.3.1	Collective Display of Command Values	6 - 14
6.4	SETTING JOB	6 - 15
6.4.1	Internal Switch Function *	6 - 15
6.4.2	Software Switch Function *	6 - 16
6.4.3	Macro Variable Function	6 - 17
6.4.4	Setting Function	6 - 19

6.1 PROGRAM JOB

The program job means the job in which the operation is executed using the created part program. This section describes how to execute the part program.

6.1.1 Program Information Displayed on Screen

To execute the part program, first call the RUNNING screen.

When the [PROG] (f1) job soft-key is pressed, the list of the programs presently executed and the execution information are displayed. The display screen is generally classified into four display blocks.

(1) Displaying and Editing the Execution Program

For the display of the program to be executed, the contents of the display differ depending on the selected automatic NC operation mode (memory, MDI, tape). In the manual mode, the contents of the searched part program are displayed.

In the memory mode, it is possible to edit the program displayed on the screen by pressing the [EDIT] (f5) function soft-key. When the NC is in the edit enabled state, the list of programs is displayed with a frame.

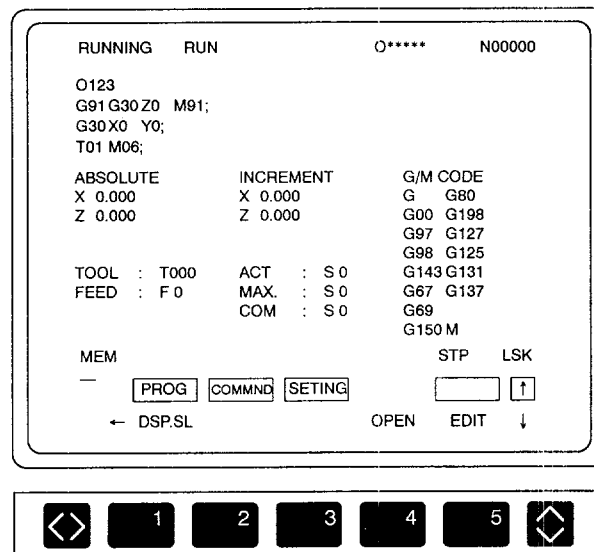

Fig. 6.1 Program Execution Display Screen

(2) Display of G Codes and M Codes

Modal G codes, non-modal G codes, and M codes that are being executed or those immediately before the execution in automatic mode operation (TAPE, MEM, or MDI) are displayed. Concerning the modal G codes, those in the most important 14 groups of 23 G code groups supported by the NC are displayed. With the non-modal G codes, if no non-modal G codes are specified, only character G is displayed. Concerning the M codes, the specified M code numbers are displayed as a 3-digit number.

(3) Display of Present Position Value and Remaining Distance

These display data facilitates checking of a program.

(4) Display of Tool Number, Feedrate, and Spindle Speeds

For TOOL, FEED, ACT, MAX., and COM, the values immediately before the execution or those being executed are displayed.

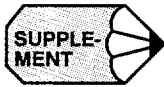

-
1. Note that the display of “ACT S” is optional.
 2. For the machine equipped with a rotary tool, the rotary tool speed is also displayed.
-

6.1.2 Program Number Search

It is possible to call the program by specifying its program number. The program can be called by the following two methods.

(1) Using the [OPEN] (f4) Function Soft-key

- ① Select the memory or tape mode with the MODE SELECT switch on the machine operation panel.
- ② Press the [OPEN] (f4) function soft-key. The message “SPECIFY PROGRAM NUMBER TO CALL” is displayed.
- ③ Key in the program number beginning with address “O”.
- ④ Press the [WR] key.

(2) Entering the Program Number

- ① Select the memory or tape mode with the MODE SELECT switch on the machine operation panel.
- ② Key in the program number.
- ③ Press the cursor up or down key.

(a) In the memory mode

Program number search is executed for the stored programs and the specified program is called. When the specified program is called, the execution program number displayed at the upper right area of the screen is changed to the called program number. If the specified program is not found, the warning message "O NO. NOT FOUND !" is displayed.

Whether the program previously called should be called or not when the power is turned ON can be selected by the setting for the parameter.

pm3005 D1 = 0	Program number is cleared when the power is turned ON.
pm3005 D1 = 1	Program number is not cleared when the power is turned ON.

(b) In the tape mode

Program number search is executed after reading the program data (tape) from the selected RS-232C input port (No. 1 port, No. 2 port). During program search, the "SEARCHING" message is displayed on the screen. Tape reading stops after the programs have been read. If the specified program number is not found in the program data having been read, the warning message "O NO. NOT FOUND !" is displayed.

After the completion of program number search, press the CYCLE START switch on the machine operation panel, and the reading of program data (tape) restarts and the program is executed. The list of the programs being executed is displayed on the screen.

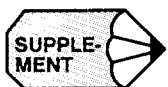

1. If an attempt is made to execute program number search in the manual mode, the message "MODE IS UNSUITABLE" is displayed.
2. When entering a program number, leading zeros can be omitted.

6.1.3 Address Search

The data (character-string) entered from the NC operation panel is compared to the data (tape) input from the RS-232C port or the data (character-string) in the memory, and the display stops when the data match. The object of search is the data (tape) input from the RS-232C port in the tape mode, part program in the memory mode, and the MDI program in the MDI mode.

(1) In the Memory Mode

Key in the word to be searched and press the cursor up or down key.

- When the cursor up key is pressed, search is executed from the present cursor position to the beginning of the data.
- When the cursor down key is pressed, search is executed from the present cursor position to the end of the data.

During address search, the “SEARCHING” message is displayed.

(2) In the Tape Mode

The program data (tape) is read from the RS-232C port and the specified character-string is searched for. During address search, the “SEARCHING” message is displayed, but data having been read are not displayed. Reading of the data stops when the specified character-string is read.

If the specified character-string is not found in the read data (tape), the warning message “NOT FOUND !” is displayed.

After the completion of address search, press the CYCLE START switch on the operation panel, and the reading of program data (tape) restarts and the program is executed. The list of the programs being executed is displayed on the screen.

(3) Status after the Completion of Search

Upon completion of the search, the message is cleared and the cursor is positioned on the searched word. If the word to be searched is not found, the corresponding warning message “NOT FOUND !” is displayed.

Using the cycle start operation after the completion of address search, the program is executed from the block where the cursor is positioned.



1. For the address search operation, leading zeros may be omitted in the data to be specified. Decimal point processing is also executed during search according to the input unit (mm or inches). Therefore, it is possible to execute search for the command having the same meaning (e.g. X1. = X1000). (Binary search function)
2. Address search is not possible in the alarm state.
3. The operation to search a sequence number which is specified by address N is called sequence number search.

6.1.4 Editing the Part Program Stored in Memory

Follow the procedure indicated below to edit a part program.

- ① Press the [EDIT] (f5) function soft-key while a part program is selected in the memory mode. The part program presently selected can be edited. When the edit function is called, a frame is displayed on the program display screen. In the edit function called in this job, expanded edit function can be used the same as with editing by the edit function called in the edit process. Four lines of a part program are displayed.
- ② If the [DSP.SL] (f1) function soft-key is pressed in this state, 13 lines of a part program are displayed.
- ③ After completing the editing, press the [EDIT] (f5) function soft-key once again. The part program is stored and the edit mode ends. While the part program is being stored, the message of "SAVING" is displayed.

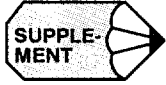

1. If the [EDIT] (f5) function soft-key is pressed while a program is being executed, it is not possible to edit the program. However, program editing is possible if the NC is in the single-block stop state.
 2. Cycle start is not possible while a program is being edited. To execute cycle start, complete program editing first. In this case, the program is restarted from the block on which the cursor is positioned after the editing. Therefore, pay attention to the cursor position when completing the editing.
 3. The [EDIT] (f5) function soft-key is not displayed in the MDI and tape mode.
 4. If the [RESET] key is pressed, the cursor moves to the beginning of the program even during editing.
 5. Even in the edit status, it is possible to call another program by following the operation explained in 6.1.2, "Program Number Search". However if the cursor up/down key is pressed after inputting address "O", character "O" is searched in the program being edited.
-

6.1.5 Execution of a Part Program

Follow the procedure indicated below to execute a part program.

- ① Select the memory mode by placing the MODE SELECT switch on the machine operation panel in the MEM position.
- ② Enter the program number from the NC operation panel and execute program search. The list of the part program is displayed on the screen and the cursor is displayed in a highlighted block.
- ③ Press the CYCLE START switch on the machine operation panel. Execution of the part program starts and the cursor is positioned at the beginning of the block presently executed.



If the CYCLE START switch is pressed while the cursor is positioned in the middle of a block, how that block is executed is determined according to the setting for the parameter.

pm4008 D3 = 0	The block is executed from the word on which the cursor is positioned.
pm4008 D3 = 1	The block is executed from the beginning.

6.1.6 Display of Subprogram Nesting Information

When the page key is pressed, the subprogram nesting information is displayed.

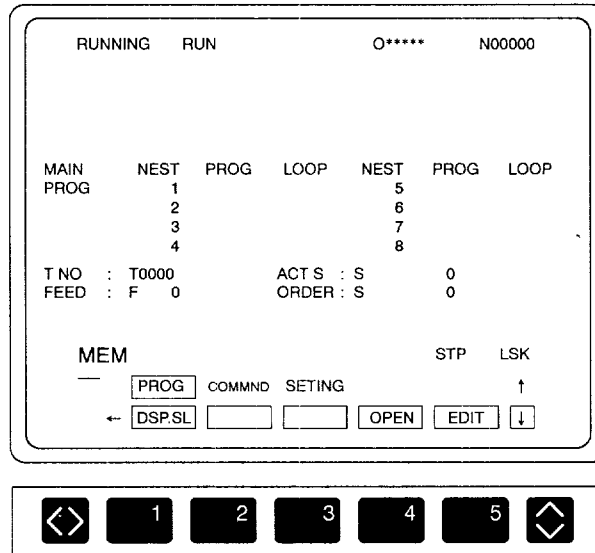

Fig. 6.2 Nesting Information Display Screen

6

On the subprogram nesting information display screen, the main program number and the subprogram numbers are displayed. For the subprograms, the number of loops is displayed for up to a nesting level of eight. The program presently executed is indicated by the symbol of “→”. Subprogram call is executed by M98.

Macroprogram call is also displayed on this screen. While a program is being executed in the memory mode, the subprogram nesting information is not displayed even if a page key is pressed. In this case, the display page of the program being edited is changed.

6.2 MDI OPERATION JOB

The job to execute an automatic operation by manually inputting a program is called the MDI operation job. This section describes the MDI operation procedure.

6.2.1 Entry of an MDI Program

An MDI program of a maximum of 1024 characters can be entered by the following operation. If a program exceeding 1024 characters is entered, the warning message “OVER MDI BUFFER !” is displayed.

- ① Select the MDI mode by placing the MODE SELECT switch on the machine operation panel in the MDI position. On the screen, “EOB” is displayed in the execution program display area. In this status, MDI program can be entered by using the address and data keys.
- ② Key in the required address and data, and press the [WR] key.

The entered data are stored to the MDI buffer.

6.2.2 Editing an MDI Program

The MDI program entered to the MDI buffer can be edited in the same manner as with the part program stored in the memory.

- When the cursor up/down key is pressed, the cursor moves forward or backward in units of blocks of MDI program.
- When the cursor right/left key is pressed, the cursor moves forward or backward in units of words.
- When the page key is pressed, the MDI program is moved forward or backward in units of pages.
- When the [INSRT] key is pressed, the entered data are inserted following the present cursor position.
- When the [ALTER] key is pressed, the word on which the cursor is positioned is replaced with the entered word.
- When the [ERASE] key is pressed, the word on which the cursor is positioned is erased.
- When [WR] key is pressed, the entered word is appended to the existing MDI program.
- Whether or not the MDI buffer should be cleared by pressing the [RESET] key can be selected by the setting for the parameter.

pm3002 D1 = 0	MDI buffer is cleared by the reset signal.
pm3002 D1 = 1	MDI buffer is not cleared by the reset signal.



1. The MDI program cannot be edited while it is executed. However, editing is possible in the single-block stop state.
2. After completing the MDI program editing, cycle start the edited program. In this case, pay attention to the cursor position since the program is restarted from the cursor position.
3. When the [BT/TOP] (f5) function soft-key is pressed, the cursor moves to the bottom line of the MDI program. When the [BT/TOP] (f5) function soft-key is pressed once again, the cursor moves to the top line of the MDI program.
4. When the setting is made so that the MDI buffer is not cleared by the reset signal, the cursor position is determined by the setting for the parameter.

pm4002 D1 = 0	The cursor is returned to the beginning of the program.
pm4002 D1 = 1	The cursor stays at the same position.

6.2.3 Execution of an MDI Program

With the MODESELECT switch on the machine operation panel placed in the MDI position, press the CYCLESTART switch, and the entered MDI program is executed. Execution starts from the block where the cursor is positioned.

- As the MDI program is executed, the cursor moves at the beginning of the block which is presently executed.
- For the execution of the MDI program, the [RUN] process is not necessarily selected. It is possible to execute the MDI program from any display screen as long as the MDI program has been entered.
- Whether or not the MDI program should be cleared upon completion of the execution of the MDI program can be selected by the setting for the parameter.

pm3002 D1 = 0	MDI buffer is cleared upon completion of MDI program execution.
pm3002 D1 = 1	Single-block mode and MDI buffer are not cleared upon completion of MDI program execution if an end M code (M02, M30) exists.

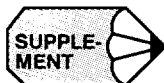

In the single-block stop state, editing an MDI program and the cursor movement by the cursor keys and the [BT/TOP] (f5) function soft-key are permitted.

6.2.4 Deleting an MDI Program

When the MODE SELECT switch on the machine operation panel is placed in the MDI position, delete function is displayed ([DELETE] (f2) function soft-key). When the [DELETE] (f2) function soft-key is pressed, the MDI program is deleted.

This key is conveniently used when parameter setting is made so that the MDI buffer is not cleared by the reset operation or when the [RESET] key cannot be pressed during MDI operation intervention.

6.2.5 Storing an MDI Program

To store the MDI program in the memory, follow the procedure indicated below.

- ① In the MDI mode, press the [SAVE] (f4) function soft-key. Note that the [SAVE] function menu item is displayed only in the MDI mode. The message "INPUT O NO." is displayed.
- ② Enter the program number for storing the MDI program. For example, key in "O20" and press the [WR] key. The message of "INPUT COMMENT" is displayed.
- ③ Enter the comment. For example, key in "DRILL" and press the [WR] key.

6.3 COMMAND VALUE DISPLAY JOB

The job to display the command values in the program presently executed is called the command value display job. This section describes the procedure used for displaying the command values.

6.3.1 Collective Display of Command Values

It is possible to display all command values of the program presently executed. When the [COMMND] (f2) job soft-key is pressed, the command value display screen is displayed as shown in Fig. 6.3. On this screen, the data of the block being executed in the automatic mode are displayed.

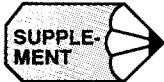

1. During automatic operation or in the feed hold state, the contents of the execution register are displayed.
2. In the block stop state, the contents in the buffer area are displayed. If the buffer area is <empty>, the contents of the block executed previously are displayed.

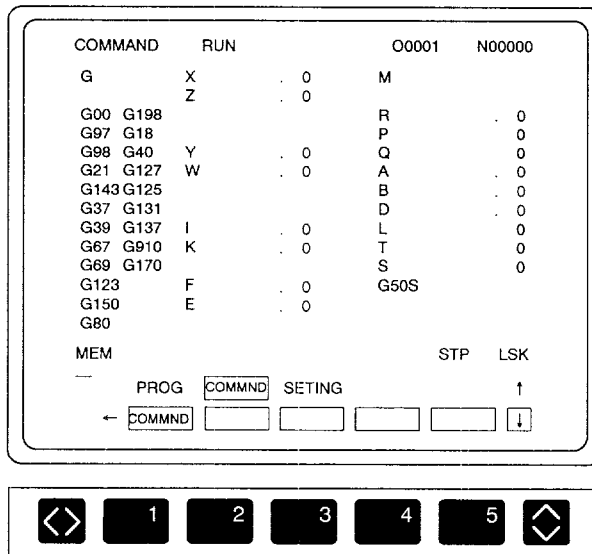

Fig. 6.3 Command Value Display Screen

6.4 SETTING JOB

Various data necessary for operating the NC can be set by the setting job. When the [SETTING] (f3) job soft-key is pressed, any of the following functions may be displayed.

- SWITCH (internal switch) function
- SOFTSW (software switch) function
- MACRO (macroprogram variable) function
- SETING (setting) function

6.4.1 Internal Switch Function *

By using the switches displayed on this screen, they can be turned ON or OFF without using the switches on the machine operation panel. Up to 15 switches are displayed on two pages. The number of switches displayed by this function varies depending on the selected options.

- ① When the [SWITCH] (f1) function soft-key is pressed, the internal switch screen (Fig. 6.4) is displayed.

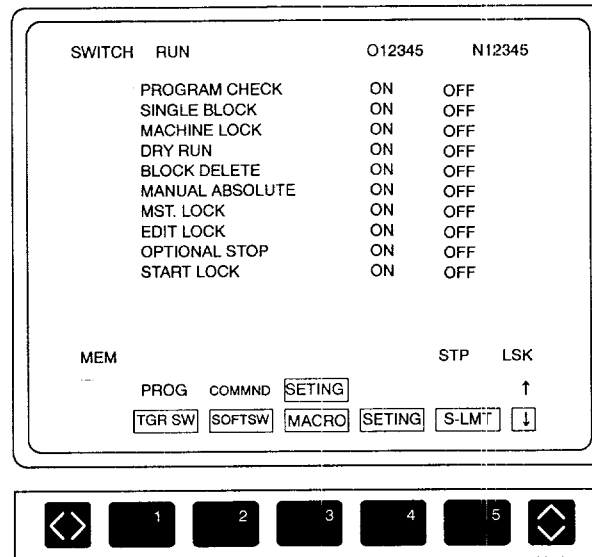

Fig. 6.4 Internal Switch Screen

- ② Move the cursor to the switch to be turned ON or OFF, then press the [WR] key. Each time the [WR] key is pressed, the switch status toggles between ON and OFF. The new setting of the switch becomes valid immediately.



When the PROGRAM CHECK switch is set ON, it is possible to set ON the MACHINE LOCK, DRY RUN, and MST. LOCK switches at a time. This function is convenient for checking a new program before using it for production. In this setting, if the PROGRAM CHECK switch is turned OFF, the three switches are turned OFF at a time.

6.4.2 Software Switch Function *

By selecting the optional software switch function, it is possible to substitute the switches on the operation panel with the switches provided on this screen. When the [SOFT SW] (f2) function soft-key is pressed, the software switch selection screen is displayed. A maximum of 64 points of software switches can be used; this uses a maximum of eight pages for display.

For details, refer to the manuals published by the machine tool builder.

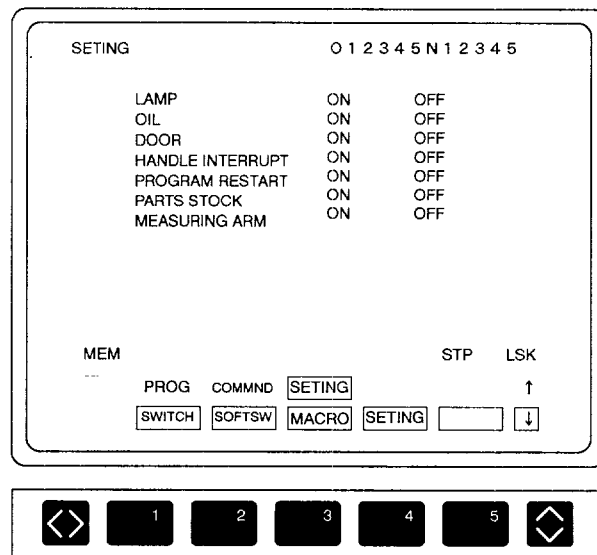

Fig. 6.5 Software Switch Screen

6

6.4.3 Macro Variable Function

When the optional macroprogram function is used, it is possible to display and write the local variables (#1 to #33) and common variables (#100 to #299, #500 to #999).

- ① When the [MACRO] (f3) function soft-key is pressed, the local variables and the nesting level are displayed.
 - Nesting level is indicated by the symbol in the range of LVL0 to LVL4. The nesting level of the macroprogram which is presently executed is indicated by the symbol and a numerical value.
 - The values of the local variables in the present level are displayed by a signed data string (integer: 8 digits, decimal fraction: 7 digits).
 - The values of the local variables used in a different level cannot be viewed on this screen.
 - If the data area is blank, it indicates the local variable is <empty>. After the execution of a macroprogram, local variable data are displayed in blank.
 - For common variables, nesting level is not displayed.

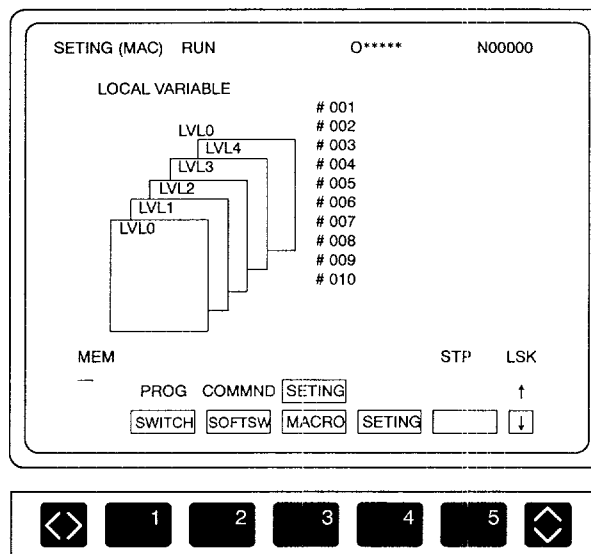
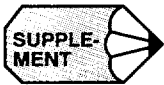

Fig. 6.6 Local Variable and Nesting Level Display Screen

-
- ② It is possible to search the variable by directly specifying the variable number. After entering the variable number, press the cursor up/down key, and the specified variable is displayed on the screen. The other method to search the variable uses the page keys and the cursor up/down keys. Display the screen that includes the required variable by pressing the page keys and move the cursor to the required variable by pressing the cursor up/down keys.
 - ③ After keying in the numerical value, press the [WR] key. The entered value is stored to the variable that is specified by the cursor.



-
1. Common variables can be written any time.
 2. Local variables can be written only while a macroprogram is executed. If an attempt is made to write, it will be invalid. However, since it is very risky to change the contents of local variables while a macroprogram is being executed, suspend the execution of the macroprogram once by single-block stop to change the contents. When changing the contents, make sure that changing the contents does not cause problems.
-

6.4.4 Setting Function

- ① When the [SETTING] (f4) function soft-key is pressed, the setting screen as shown in Fig. 6.7 is displayed.
- ② Either press the page keys or key in the page number. Display the page which includes the objective setting item by pressing the cursor up/down keys.
- ③ Move the cursor to the required setting item by using the cursor up/down key.
- ④ For the items for which setting should be made in other than numerical values, the contents of the setting changes each time the [WR] key is pressed. Selection is made from “ON and OFF”, “ISO and EIA”, “MM and INCH”, etc. For the items for which setting should be made in numerical values, press the [WR] key after keying in the required value.

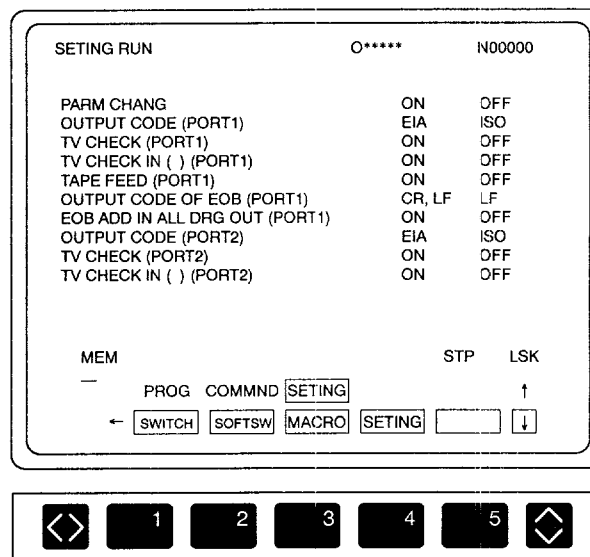

Fig. 6.7 Setting Screen



By using the PARM CHANG switch, it is possible to change the parameter data in the PARAM and SEQ PRM functions in the MAINT process. This switch is linked to setting parameter pm0109.

Switch ON	Parameter data can be changed.
Switch OFF	Parameter data cannot be changed.

- If the switch is set ON, cycle start is made invalid. Therefore, the switch must always be returned to OFF after changing the parameter data.
- When the SETING function is used, parameter data can always be changed disregarding of the parameter data change enabled/disabled status set by the switch.

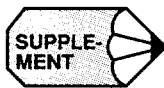

The items to be set on this screen correspond to the setting parameters that are displayed by the SETING function in the PARAM job of the MAINT process.

For the correspondence between the items displayed on the SETING screen and the setting parameter numbers, refer to Appendix 2 PARAMETER TABLE.

7

COMMON PROCESS OPERATION

Chapter 7 describes the operation carried out by using the common process key.

In the common process, present position data display, coordinate system setting, alarm display, calendar display, and operating time display are given by the present position data control job, alarm display job and time control job.

Job selection is possible by using either the job soft-keys or the [COMN] process selection key.

7.1 PRESENT POSITION DATA CONTROL

JOB 7 - 2

7.1.1 Collective Display of Present Position Data .. 7 - 2

7.1.2 Display of Present Position Data in the Workpiece Coordinate System 7 - 4

7.1.3 Display of Present Position Data in the External Coordinate Values 7 - 5

7.1.4 Display of Remaining Distance 7 - 6

7.1.5 Setting the Coordinate Systems 7 - 7

7.1.6 Error Pulse Display Function 7 - 9

7.2 ALARM DISPLAY JOB 7 - 10

7.2.1 Alarm Function 7 - 10

7.2.2 Servo Alarm Function 7 - 11

7.2.3 User's Message Function 7 - 12

7.3 TIME CONTROL JOB 7 - 13

7.3.1 Calendar Function 7 - 14

7.3.2 Operating Time Function 7 - 15

7.1 PRESENT POSITION DATA CONTROL JOB

The present position job displays the position data and also permits the setting of the position data.

When the [POSIT.] (f1) job soft-key is pressed, any of the following functions may be displayed.

- ALL (collective display) function
- ABS (absolute position) function
- EXTERN (external coordinate value) function
- INCR (remaining distance) function
- ERROR (error pulse) function

7.1.1 Collective Display of Present Position Data

When the [ALL] (f1) function soft-key is pressed, the present position data collective display screen is displayed.

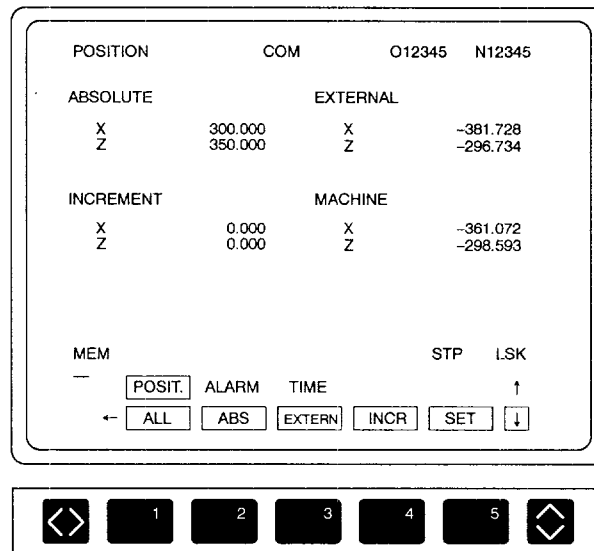

Fig. 7.1 Present Position Data Collective Display Screen

The following describes the individual functions.

(1) ABS (Workpiece Coordinate System)

The coordinate values of a cutting tool in the set workpiece coordinate system are displayed. Whether or not the tool offset data are included in the coordinate values to be displayed here can be selected by the setting for the parameter.

pm3000 D2 = 0	Tool offset data are included.
pm3000 D2 = 1	Tool offset data are not included.

The workpiece coordinate system can be preset by using [SET] of the [POSIT.] function (see 7.1.5, “Setting the Coordinate Systems”).

(2) EXTERNAL (External Coordinate Values)

Accumulated travel distance of a cutting tool is displayed in reference to the position preset by using the preset operation.

(3) INCREMENT (Remaining Distance)

The following values are displayed.

- In the automatic operation mode, the distance from the present position of the cutting tool to the end point of the block being executed is displayed.
- In the manual operation mode, the distance is measured from the present position of the cutting tool to the manual operation start point. This display is reset to “0” when the operation mode is returned to manual.

(4) MACHINE (Machine Coordinate System)

The present position of the cutting tool is displayed in the coordinate system that has its origin at the position where the axes are positioned by the reference point return operation.

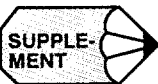

The axis names displayed on the screen are those set for parameter pm1100. If no axis name is set for this parameter, the default axis names are displayed.

7.1.2 Display of Present Position Data in the Workpiece Coordinate System

When the [ABS] (f2) function soft-key is pressed, the present position data in the workpiece coordinate system are displayed.

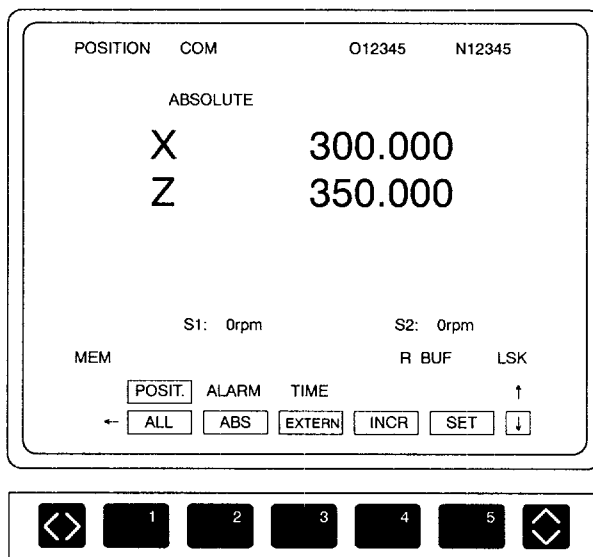

Fig. 7.2 Workpiece Coordinate System Display Screen

7.1.3 Display of Present Position Data in the External Coordinate Values

When the [EXTERN] (f3) function soft-key is pressed, the external coordinate values are displayed.

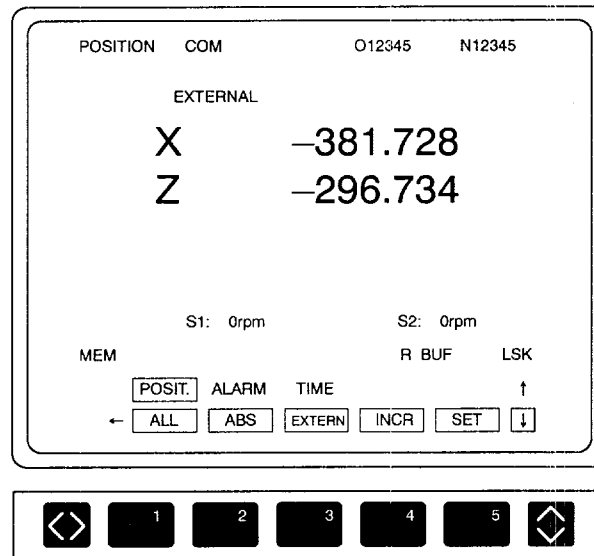

Fig. 7.3 External Coordinate System Display Screen

7.1.4 Display of Remaining Distance

When the [INCR] (f4) function soft-key is pressed, the remaining distance is displayed.

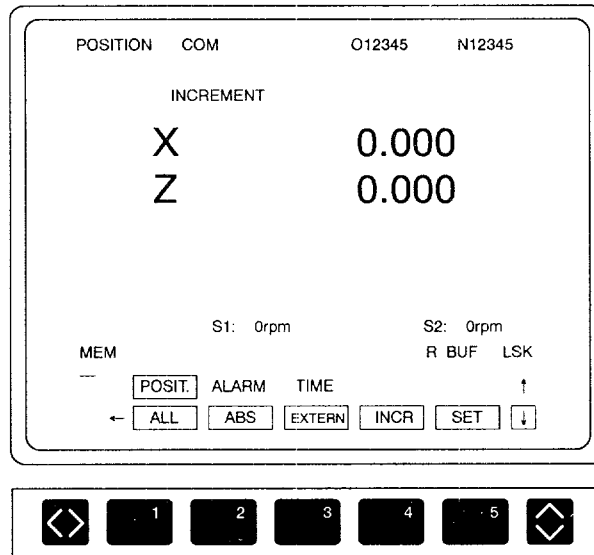

Fig. 7.4 Remaining Distance Display Screen

7.1.5 Setting the Coordinate Systems

By pressing the [ALL] (f1), [ABS] (f2), or [EXTERN] (f3) function soft-keys, the coordinate systems can be set.

(1) Outline of the Setting in Each Function

(a) All function

When the [ALL] (f1) function soft-key is pressed, the external coordinate system can be set. The external coordinate system can always be set, even while an axis is moving in automatic operation of a part program.

(b) Coordinate system function

When the [ABS] (f2) function soft-key is pressed, the workpiece coordinate system can be set. This function is valid in manual operation mode (rapid traverse, jog feed, step feed, handle feed). If an attempt is made to set a workpiece coordinate system in a mode other than manual mode, the warning message "CAN'T SET COORD!" is displayed.

(c) External coordinate system function

When the [EXTERN] (f3) function soft-key is pressed, the external coordinate system can be set. The external coordinate system can always be set, even while an axis is moving in automatic operation of a part program.

(2) Setting the Coordinate Systems

Follow the procedure indicated below to set a coordinate system.

- ① When the [SET] (f5) function soft-key is pressed, the key is highlighted and, at the same time, the name of the axis for which a coordinate value can be set is highlighted.

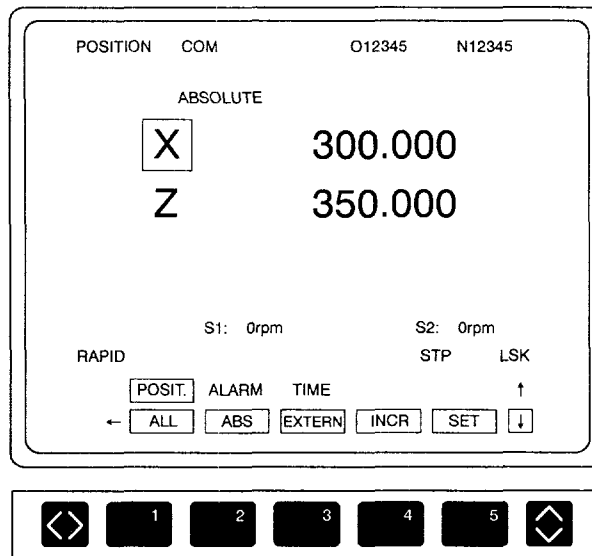
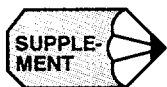

Fig. 7.5 Workpiece Coordinate System Setting Screen

- ② Move the cursor to the axis for which the coordinate value should be set by using the cursor up/down keys.
- ③ The coordinate system is set when a coordinate value is entered and the cursor moves to the next axis name. For example, key in "210.5" and press the [WR] key. The coordinate system is set based on the entered value.
 - If the [WR] key is pressed without keying in a coordinate value, the coordinate system is set assuming "0".
 - If the [WR] key is pressed after keying in the "/" code, one-half of the position data value is entered and the coordinate system is set accordingly.
- ④ When the [SET] (f5) function soft-key is pressed, the cursor on the axis name disappears.



1. If an attempt is made to set a coordinate system in the mode in which a coordinate system cannot be set, the warning message "CAN'T SET COORD." is displayed.
2. The operation to set the coordinate system in the present position data control job is called the numerical setting up.

7.1.6 Error Pulse Display Function

The error pulse screen is displayed when the [ERROR] (f1) function soft-key is pressed.

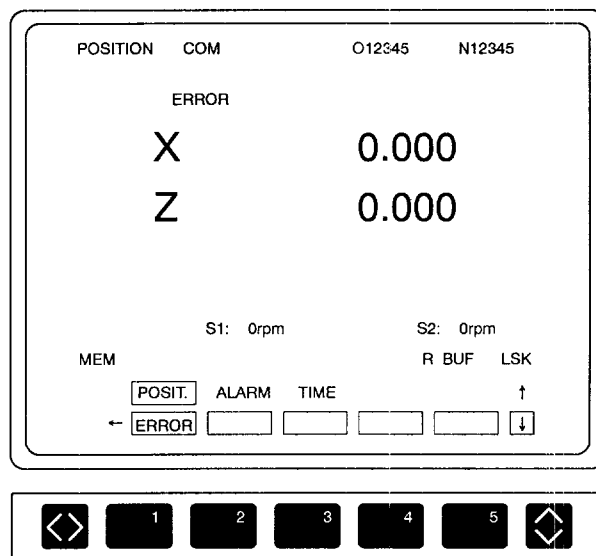

Fig. 7.6 Error Pulse Display Screen

On the error pulse display screen, the contents of the command pulse accumulation registers in the NC are displayed. The command pulse accumulation registers are reset to "0" when the power is turned ON, and command pulses are all accumulated in these registers after that.

7.2 ALARM DISPLAY JOB

The alarm display job displays the contents of the alarm if an alarm occurs with the NC unit.

When the [ALARM] (f2) job soft-key is pressed, any of the following functions may be displayed: alarm function, servo alarm function, and user's message function.

7.2.1 Alarm Function

If an alarm occurs with the NC unit, "ALM" or "BGA" (background alarm) message is displayed in the alarm status display area in the screen regardless of the mode or process. If battery alarm occurs at the same time, either "A/B" or "B/B" is displayed in blinking characters. At the same time, the alarm number of the alarm having the highest priority is displayed with the corresponding alarm message and alarm occurring program line in the alarm message display area.

When the [ALARM] (f1) function soft-key is pressed, the screen changes to the alarm display screen where alarm information of all alarms that have occurred is displayed. The alarm numbers and the alarm messages are displayed in the order of priority.

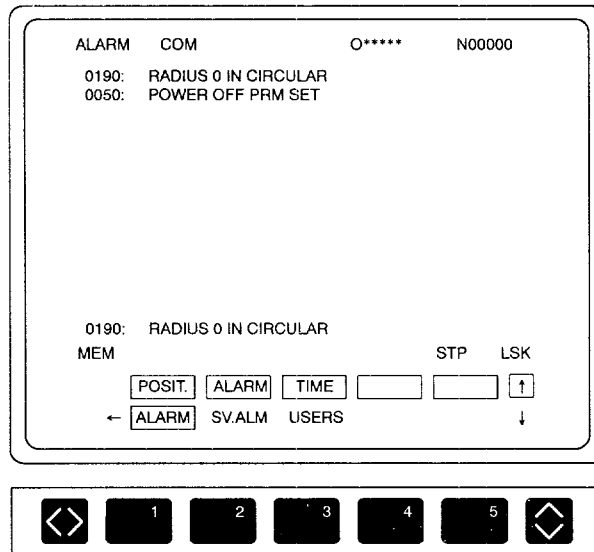

Fig. 7.7 Alarm Message Display Screen

7.2.2 Servo Alarm Function

When an alarm occurs with the servo controller (SERVOPACK), the alarm information is displayed on the screen. Follow the procedure indicated below.

- ① When the [SV.ALM] (f2) function soft-key is pressed, the servo alarm display screen is displayed as shown in Fig. 7.8. If an alarm related with the SERVOPACK is displayed on the alarm message display screen (Fig. 7.7), details of the SERVOPACK related alarm can be checked on this screen.

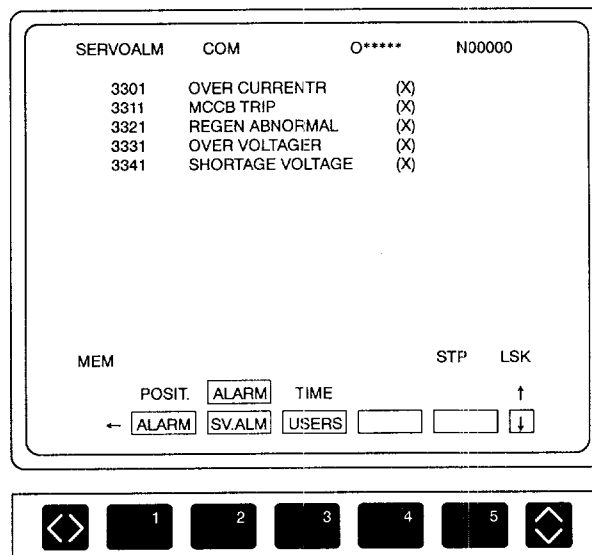

Fig. 7.8 Servo Alarm Display Screen

- ② If alarms cannot be displayed on one page of the display screen, they are displayed on more than one page. To change the display page, use the page keys. If alarm display is given on one page, the page keys are invalid.

7.2.3 User's Message Function

The function displays user's message on the screen by the PLC system (machine sequence controller) in the NC unit. Usually, this function is used to display the outline of the alarm detected by the PLC. However, this function is also used to simply display the message.

When the message display instruction (macro instruction) is executed in the PLC, either "ALM" or "A/B" blinks at the alarm status display area.

(1) When the [ALARM] (f1) Function Soft-key is Pressed

The following display is given.

- ALM 1080 SEQUENCE ERROR 0
- ALM 2180 SEQUENCE ERROR 1
- ALM 3240 SEQUENCE ERROR 2

(2) When the [USERS] (f3) Function Soft-key is Pressed

The user's message screen is displayed where detailed error codes output from the PLC are displayed. For details, refer to the manuals published by the machine tool builder.

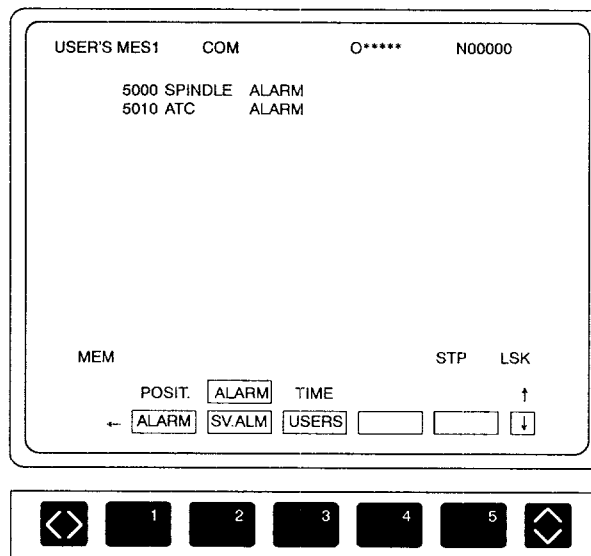

Fig. 7.9 User's Message Screen

7.3 TIME CONTROL JOB

The time control job allows the display and setting of the date and time using the calendar function. When the operating time data are selected, operating time data can be displayed and set.

When the [TIME] (f3) job soft-key is pressed, either the calendar screen or the operating time screen is displayed. The [CALEN] (f1) and [W.TIME] (f2) function soft-keys are used to change the display screen.

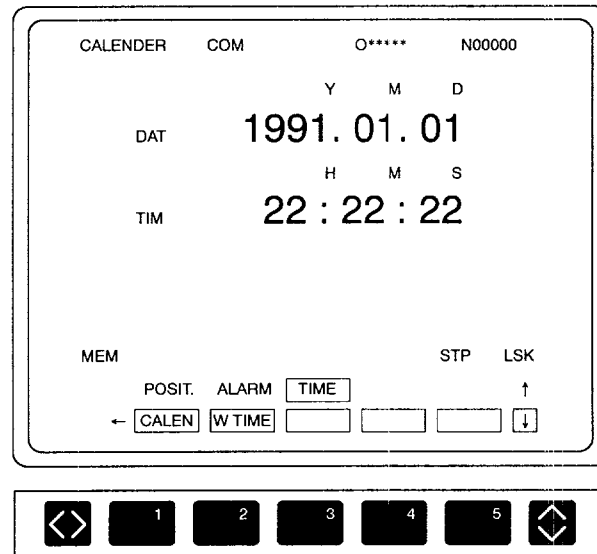

Fig. 7.10 Calendar Display Screen

7.3.1 Calendar Function

(1) Calendar Display

When the [CALEN] (f1) function soft-key is pressed, the calendar screen is displayed where the NC's calendar data (date and time) are displayed.

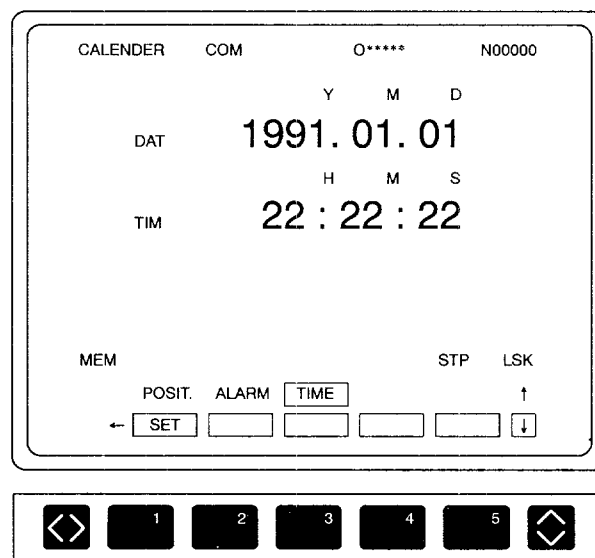

Fig. 7.11 Calendar Setting Screen

(2) Calendar Setting

- ① Press the FUNCTION SELECT key to display the [SET] (f1) function soft-key.
- ② When the [SET] (f1) function soft-key is pressed, the calendar setting mode is called and the [SET] (f1) function soft-key is highlighted. At the same time, the cursor is displayed on "DAT".
- ③ Selection of date and time is possible by moving the cursor. The cursor up/down keys are used to move the cursor.
- ④ Set the date. For example, key in "1991.01.01" and press the [WR] key.
- ⑤ Set the time. For example, key in "22.22.22" and press the [WR] key.
- ⑥ When the [SET] (f5) function soft-key is pressed, the cursor disappears and the newly entered date and time are displayed.

7.3.2 Operating Time Function

The NC accumulates operating time in the individual operation modes and the contents of the accumulated time data can be displayed on the screen. This function allows the analysis of cycle time used to finish one workpiece and also the checking of total NC unit running time. The operating time is displayed on the following four modes and time data are displayed in units of hours, minutes, and seconds.

POWER ON	Displays the total accumulated time after turning the power ON.
CYCLE ST	Displays the total accumulated time in which the NC has operated in the automatic mode.
CUTTING	Displays the total accumulated time in which the NC has operated in the cutting mode.
TIMER*	Displays the total accumulated time in which external input signals have been ON. (option)

- ① Press the [W TIME] (f2) function soft-key.
- ② To reset the displayed time data, display the [0 CLR] (f1) function soft-key first by pressing the FUNCTION SELECT key.
- ③ When the [0 CLR] (f1) function soft-key is pressed, the key is highlighted and, at the same time, the cursor is displayed on the POWER ON item, indicating that the zero clear mode has been set.

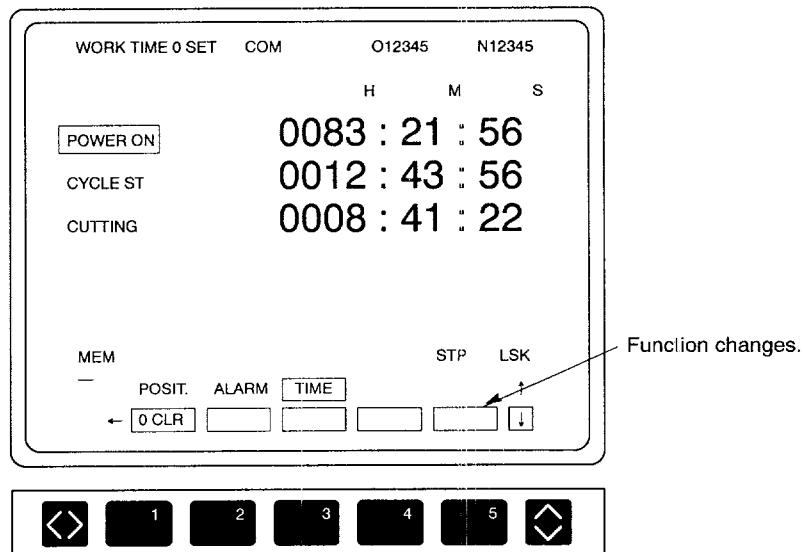

Fig. 7.12 Zero Clear Mode Screen

-
- ④ To clear the time data to “0”, move the cursor to the item to be cleared and press the [WR] key. The time data of the item on which the cursor is positioned are cleared to “0” and the cursor moves to the next item.
 - ⑤ When the [0 CLR] (f1) function soft-key is pressed, the cursor disappears and the zero clear mode is canceled.

8

MAINTENANCE PROCESS

Chapter 8 describes the operation carried out by using the maintenance process key.

In the maintenance process, display and setting of the data necessary to maintain the NC unit and input/output of the data using an external device are executed by the parameter job, I/O monitoring job, input/output and verify job, and internal information job.

Job selection is possible by using either the job soft-keys or the [MAINT] process selection key.

8.1	PARAMETER JOB	8 - 3
8.1.1	Parameter Function	8 - 3
8.1.2	Setting Function	8 - 6
8.1.3	Sequence Parameter Function	8 - 7
8.1.4	Pitch Error Function *	8 - 7
8.2	I/O MONITORING JOB	8 - 8
8.2.1	Displaying the ON/OFF Status of the I/O Signals	8 - 8
8.2.2	Displaying the ON/OFF Status of the Selected I/O Signals	8 - 9
8.2.3	Turning ON/OFF I/O Signals Forcibly	8 - 11

8.3	INPUT/OUTPUT AND VERIFY JOB	... 8 - 12
8.3.1	Input/output and Verify Function	8 - 12
8.3.2	Reset Function	8 - 14
8.3.3	I/O Device Setting Function	8 - 14
8.4	INTERNAL INFORMATION JOB 8 - 15
8.4.1	Version Number Function	8 - 15
8.4.2	Memory Dump Function	8 - 16
8.4.3	Key Memory Function	8 - 16

8.1 PARAMETER JOB

With the parameter job, the data stored in the internal memory (parameter data, setting data, battery back-up memory data, pitch error compensation data) can be displayed and set. According to the contents, specific functions are turned ON and OFF or the operation conditions of the functions are determined.

When the [PARAM] (f1) job soft-key is pressed, the following function soft-keys are displayed: [PARAM] (f1), [SETTING] (f2), [SEQPRM] (f3), and [P.ERR] (f4).

Before setting the parameters, set “ON” for “PARAMETER CHANG” parameter by using the [SETTING] job in the [RUN] process. With this setting, the data set for parameters, battery back-up memory, and pitch error can be changed. After the completion of changing, make sure to return the setting for “PARAMETER CHANG” to “OFF”.

CAUTION

- The end user must not change parameters relating to machine accuracy, travel axis control and spindle axis control.
The NC parameters are set to the optimum values for each machine, and changing them could therefore result in unexpected operation. This could cause tool damage due to interference, and resulting accidents involving injuries to personnel.
Reset the NC after any manual intervention.

8.1.1 Parameter Function

With the parameter function, display and setting of parameter data stored in the NC are possible. Usually, the parameter data are set by the machine tool builder and to change the setting for the parameters, make sure to consult the machine tool builder.

- ① Press the [PARAM] (f1) function soft-key.
- ② The parameters are largely classified into two types – bit type and byte/word/double-word type.

(1) Bit Type Parameters

Follow the procedure indicated below to write the bit type parameters.

- ① Move the cursor to the parameter for which the present setting should be changed. For this operation, use the page keys and the cursor up/down keys, or use the cursor up/down keys after keying in the parameter number.
- ② Press either the [INSRT] key or the cursor right key. In the case of [INSRT] key, the cursor moves to the decimal number display area and in the case of the cursor right key, the cursor moves to the bit data position.

- ③ Move the cursor to the bit position where the data should be changed and press the [WR] key. Each time the [WR] key is pressed, the bit status (ON/OFF) is changed alternately. Writing a numerical value is allowed only when the cursor is moved to the decimal number position at the right end column.

Table 8.1 Example) Writing a decimal number for bit data

Key Operation	Bit 76543210	Decimal Number
[0] [WR]	00000000	0
[8] [WR]	00001000	8
[2][5][5][WR]	11111111	255

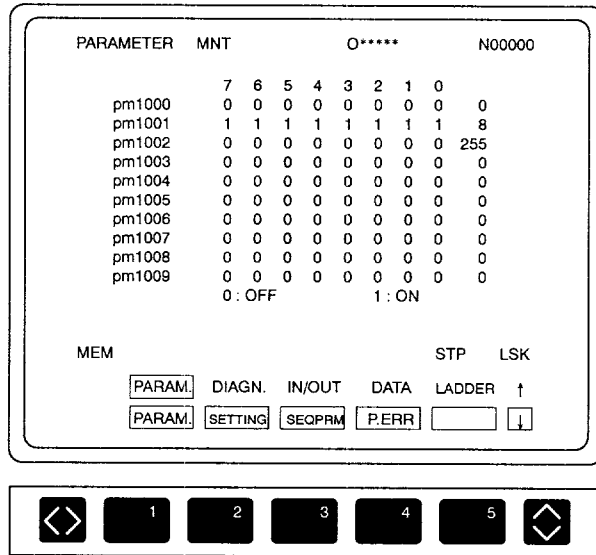

Fig. 8.1 Parameter Input Screen (Bit Type Parameters)

(2) Byte/Word/Double-word Type Parameters

Follow the procedure indicated below to write the byte/word/double-word type parameters.

- ① Move the cursor to the parameter for which the present setting should be changed. For this operation, use the page keys and the cursor up/down keys, or use the cursor up/down keys after keying in the parameter number. When parameter number search is executed, it is not necessary to enter "pm".
- ② Key in a required parameter value and press the [WR] key. The keyed in value is entered to the specified parameter.

PARAMETER	DIAGN	O*****	N00000
pm 8100		0	
pm 8101		0	
pm 8102		0	
pm 8103		0	
pm 8104		0	
pm 8105		0	
pm 8106		0	
pm 8107		0	
pm 8108		0	
pm 8109		0	

MEM			STP	LSK
[PARAM]	[DIAGN]	[IN/OUT]	[DATA]	[LADDER] ↑
[PARAM]	SETTING	SEQPRM	P.ERR	↓

◀	1	2	3	4	5	▶
---	---	---	---	---	---	---

Fig. 8.2 Parameter Input Screen
(Byte/Word/Double-word Type Parameters)

-
- ③ After changing the setting for the parameters, press the [RESET] key. The new settings become valid when the NC is reset.
- When the setting is made for the parameters that become valid after the power is turned OFF, the alarm “ALM 0050: POWER OFF PRM SET” occurs. If this alarm message is displayed, turn OFF the power once and then turn it back ON.
 - When the setting is made for the parameters that become valid when the part program is initialized, the alarm “ALM 0051: PROGRAM GENERATION PRM SET” occurs. If this alarm message is displayed, program clear is necessary.

Contact your Yaskawa representative. Even after the occurrence of this alarm, it is possible to run the NC without problems by turning OFF the power once and then turning it back ON again. In this case, the new setting is invalid.

8.1.2 Setting Function

It is possible to display the setting data stored in the NC and also to set the data. Follow the procedure indicated below.

- ① Press the [SETTING] (f2) function soft-key.
- ② Move the cursor to the setting number for which the present setting should be changed by pressing the page keys or cursor up/down keys. The cursor can also be moved to the desired setting number by pressing the cursor up/down keys after entering the parameter number.
- ③ Enter the required value.

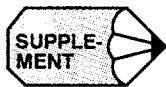

8

-
1. Operation is basically the same as with the parameter function. When changing the setting data, it is not necessary to set “ON” for the “PARAMETER CHANG” parameter.
 2. When the setting is changed for the setting data, the new data become valid immediately.
 3. A part of the setting data can be set on the setting function screen in the RUN process.
-

8.1.3 Sequence Parameter Function

With the sequence parameter function, display and setting are possible for the sequence parameters. Here, the sequence parameter refers to the data used by the PLC. Follow the procedure indicated below.

- ① Press the [SEQPRM] (f3) function soft-key.
- ② Move the cursor to the sequence parameter number for which the present setting should be changed by pressing the page keys or cursor up/down keys. The cursor can also be moved to the desired setting number by pressing the cursor up/down keys after entering the parameter number.
- ③ Enter the required parameter data. For the procedure for entering the parameter data, refer to 8.1.1, "Parameter Function".



On the bit type data display screen, the numerical values given at the right end of the column are hexadecimal numbers.

8.1.4 Pitch Error Function *

The pitch error function allows the display and setting of the pitch error compensation data stored in the NC.

- ① Press the [P.ERR] (f4) function soft-key.
- ② Move the cursor to the pitch error number for which the present setting should be changed by pressing the page keys or cursor up/down keys. The cursor can also be moved to the desired setting number by pressing the cursor up/down keys after entering the parameter number.
- ③ Enter the required pitch error compensation data. For the procedure for entering the data, refer to 8.1.1, "Parameter Function".

8.2 I/O MONITORING JOB

With the I/O monitor job, ON/OFF status of the I/O signals of the NC, PLC, and the machine can be monitored.

8.2.1 Displaying the ON/OFF Status of the I/O Signals

When the [DIAGN.] (f2) soft-key is pressed, the ON/OFF status of the I/O signals of the NC, PLC, and machine are displayed. This display can be displayed at any time.

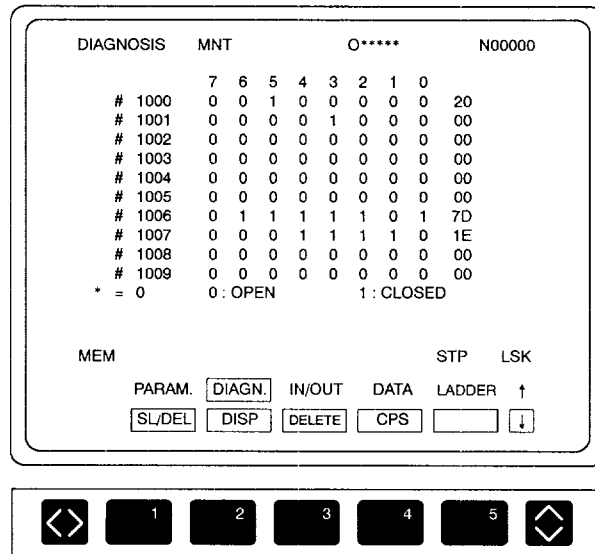

Fig. 8.3 I/O Signal Display Screen



On the I/O signal display screen, the numerical values given at the right end of the column are hexadecimal numbers.

8.2.2 Displaying the ON/OFF Status of the Selected I/O Signals

It is possible to display the ON/OFF status of the I/O signals by selecting the required ones.

- ① Move the cursor to the I/O signal number that should be selected.
For this operation, use the page keys and the cursor up/down keys, or use the cursor up/down keys after keying in the parameter number.
- ② Press the [SL/DEL] (f1) function soft-key and the selected I/O signal number is stored; the "*" symbol is displayed to the left of it. The entire number of the selected I/O signal number is displayed at the lower area of the screen (* = xx).
- ③ Repeat steps ① and ② above to select the I/O signal numbers. Selection is possible for up to ten signal numbers.

DIAGNOSIS	MNT	O*****	N00000
	7 6 5 4 3 2 1 0		
* # 1000	0 0 1 0 0 0 0 0	20	
# 1001	0 0 0 0 1 0 0 0	00	
# 1002	0 0 0 0 0 0 0 0	00	
* # 1003	0 0 0 0 0 0 0 0	00	
# 1004	0 0 0 0 0 0 0 0	00	
# 1005	0 0 0 0 0 0 0 0	00	
* # 1006	0 1 1 1 1 1 0 1	7D	
* # 1007	0 0 0 1 1 1 1 0	1E	
* # 1008	0 0 0 0 0 0 0 0	00	
# 1009	0 0 0 0 0 0 0 0	00	
* = 5	0: OPEN	1: CLOSED	

MEM		STP	LSK
—	PARAM. DIAGN. IN/OUT DATA LADDER ↑		
	SL/DEL DISP DELETE CPS [] ↓		

◀▶	1	2	3	4	5	◀▶
----	---	---	---	---	---	----

Fig. 8.4 Selected I/O Signal Screen

- ④ Press the [DISP] (f2) function soft-key. The selected I/O signal numbers are displayed.

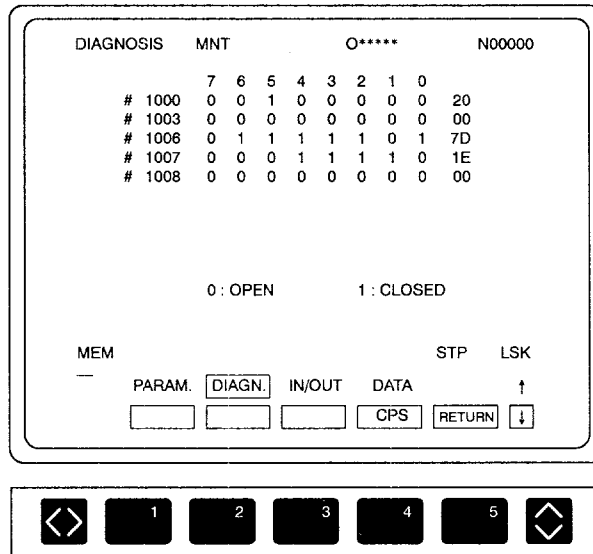

Fig. 8.5 Selected I/O Signal Display Screen

- ⑤ When the [RETURN] (f5) function soft-key is pressed, the screen returns to the I/O signal display screen which is displayed when the [DIAGN] (f2) job soft-key is pressed.
- ⑥ When the [DELETE] (f3) function soft-key is pressed, the selection of the I/O signal numbers is canceled.
- ⑦ When the [SL/DEL] (f2) function soft-key is pressed after moving the cursor to the I/O signal number that has been selected, the selection of that I/O signal number is canceled.

8.2.3 Turning ON/OFF I/O Signals Forcibly

The forced contact ON/OFF selection function is provided to check the machine sequence. This function allows the contact status to be changed forcibly without changing the machine sequence. To make this function valid, set "1" for parameter pm0109 in the [SETTING] function of [PRM] job in the [MAINT] process.

- ① Move the cursor to the I/O signal number that should be selected. For this operation, use the page keys and the cursor up/down keys, or use the cursor up/down keys after keying in the parameter number.
- ② Press the [INSRT] key. The cursor moves to the bit data area.
- ③ Move the cursor to the bit that should be selected for forced contact ON/OFF operation and press the [CPS] (f4) function soft-key. A box (□) appears at the selected bit. The box disappears when the [CPS] (f4) function soft-key is pressed again.
- ④ Press the [WR] key. Each time the [WR] key is pressed, the ON/OFF status of the selected bit is changed alternately.
- ⑤ After moving the cursor to the I/O signal number for which the "*" symbol is displayed to the left, press the [SL/DEL] (f1) function soft-key and the selection of forced contact ON/OFF operation is canceled.
- ⑥ When the [DELETE] (f3) function soft-key is pressed, selection of forced contact ON/OFF operation is canceled for all contacts.

8.3 INPUT/OUTPUT AND VERIFY JOB

The input/output and verify job allows the input and output of the NC data with an external device. It is possible to display the input/output data while the data are input from a tape reader or output to a tape punch by setting the appropriate value for the parameter.

pm0007 D5 = 0	Data are displayed on the screen during data input/output using tape.
pm0007 D5 = 1	Data are not displayed on the screen during data input/output using tape.

If data are displayed for input/output and verify operation, processing time will be extended.

8.3.1 Input/output and Verify Function

The input/output and verify function provides the following menu items.

- Input/output and verify of all parameters (setting, parameters, sequence parameters and battery back-up memory, pitch error, offset)
- Input/output and verify of setting data
- Input/output and verify of parameters (not possible for sequence parameters pm7000 to pm7099)
- Input/output and verify of sequence parameters and battery back-up memory

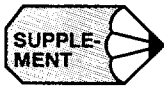

Although data are displayed in hexadecimal number for battery back-up memory, output is decimal value.

- Input/output and verify of pitch error compensation parameters (option)
- Input/output and verify of all offset data (tool offset and work coordinate system shift data)
- Input/output and verify of tool life control data (option)
- Input/output and verify of macro and common variables (option)

The input/output and verify of the data is possible disregarding of the NC operation mode. However, automatic operation is not possible during input/output and verify.

(1) Selection and Operation of the Function

- ① Press the appropriate function soft-key corresponding to the required operation. The screen is displayed corresponding to the pressed function soft-key. Fig. 8.6 shows the parameter input screen.
 - For input, press the [IN] (f1) function soft-key.
 - For output, press the [OUT] (f2) function soft-key.
 - For verify, press the [VER] (f3) function soft-key.
- ② Move the cursor to the parameter which should be input, output, or verified and press the [WR] key. The message "INPUT (OUTPUT/VERIFY) OK?" is displayed.

When the [Y] key is pressed, the selected function starts and the screen changes to the input/output/verify data display screen.

Whether or not the zero suppress function is used for these functions can be selected by the setting for the parameter.

pm0007 D6 = 0	"0" data are not output (zero suppress function)
pm0007 D6 = 1	"0" data are output.

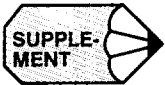

1. For the input, since only the data (other than "0") that have been output are written, "0" is not written,
2. For the verify, since only the data (other than "0") that have been output are verified, verify is not executed for the part which was "0" in output.

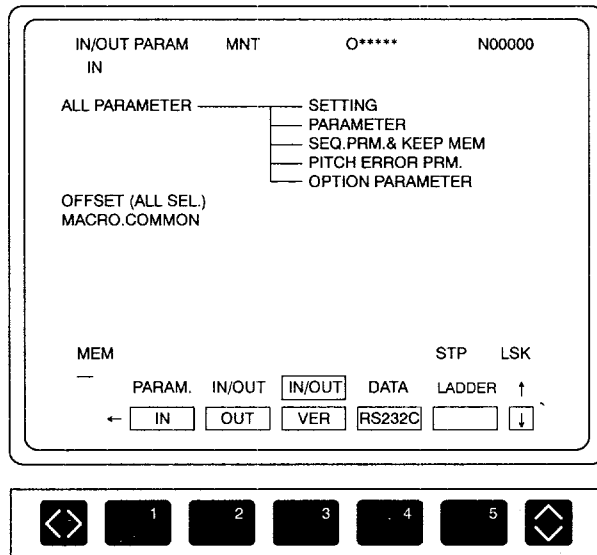

Fig. 8.6 Parameter Input Screen

8.3.2 Reset Function

The switch for background reset which provides the function different from the reset switch arranged on the NC operation panel is available. The reset function provides the following functions.

- Interruption of input/output/verify function
- Turning ON the label skip function
- Canceling the background alarm (ALM 9000)

The [RESET] (f3) function soft-key has no influence on the operation even if it is pressed during operation. If the [RESET] (f3) function soft-key is pressed, the “RST” status message is not displayed on the screen.

8.3.3 I/O Device Setting Function

It is possible to set the I/O device by pressing the [RS232C] (f4) function soft-key. For the operation procedure, refer to the [RS232C] function of the [IN/OUT] job in the [PROG] process.

8.4 INTERNAL INFORMATION JOB

Selection of each job is possible by pressing the corresponding job soft-keys ([PARAM] (f1), [DIAGN] (f2), [IN/OUT] (f3), and [DATA] (f4)), or by pressing the [MAINT] process key.

For control of the internal information, the following function soft-keys which are accessible by pressing the [DATA] job soft-key are provided: [VER NO] (f1), [DUMP] (f2), [KEY-MEM] (f3), and [SERVO] (f4).

8.4.1 Version Number Function

The version number function is provided for the purpose of maintenance and it is not used for daily operation. When the [VER NO] (f1) function soft-key is pressed, the version number list screen is displayed. On this screen, the following information is displayed.

(1) SYSTEM NO

Two system numbers (NC and PC ladder) are displayed.

(2) OPTION VERSION NO

When the option boards are installed, the software version of these option boards is displayed.

(3) BASIC VERSION NO

The software version of the basic boards is displayed.

The screenshot shows a terminal-style display with the following content:

```

VERSION NO  MNT          O*****  N00000

SYSTEM NO
NC MAIN : 08330-13
LANG : 08332-05
BOOT   : 08356-00
COM    : 08348-03
DRAW   : 08339-01
C-PACK : 08337-04
ACGC   : 08360-06

ACGC COMBINATION
A-PACK : 08361-02
NC MAIN : 08330-13
LANG : 08332-05

NC COMBINATION
COM    : 08348-00
DRAW   : 08339-00
C-PACK : 08337-04
ACGC   : 08360-06

USER
LADDER : *****
C-APL  : *****

EDIT                                STP  LSK
-                                     ↑
PARAM.  [DIAGN]  [IN/OUT]  [DATA]
[VER NO] [DUMP]  [KEY MEM] [SERVO] [ ] [ ]
  
```

Below the main display area is a row of five physical buttons labeled 1 through 5, with left and right arrow keys on the far left and right.

Fig. 8.7 Version Number Display Screen

8.4.2 Memory Dump Function

The memory dump function is provided for the purpose of maintenance and it is not used for daily operation. When the [DUMP] (f2) function soft-key is depressed, the memory dump screen is displayed. This screen is provided for the service technician of YASNAC NC.

8.4.3 Key Memory Function

When the [KEYMEM] (f3) function soft-key is pressed, the key memory screen is displayed. On the key memory screen, the history of key entry from the NC operation panel is displayed. The correspondence between the keys used and the key codes is indicated below.

List of key codes:

Alphabet, numerals, [SHIFT] + A – Z

The characters of the pressed keys are displayed. [SP] is displayed only for space bar.

Special keys:

Soft-keys

< > key	MN-L
^ key	MN-R
v		
1 key	F ₁
2 key	F ₂
3 key	F ₃
4 key	F ₄
5 key	F ₅

Cursor keys

▶ key	CU-R
▲ key	CU-U
◀ key	CU-L
▼ key	CU-D

Page keys

△ key	PG-U
▽ key	PG-D

Process keys and other keys

PROG key	PRG
SET key	SET
RUN key	RUN
MAINT key	MNT
COMN key	CMN
AUX1 key	AUX1
AUX2 key	AUX2
[RESET] key	RES
CAN key	CAN
EOB key	EOB
INSRT key	INS
ALTER key	ALT
ERASE key	ERS
WR key	WR

9

MAINTENANCE

Chapter 9 describes the maintenance data that can be accessed by the users.

9.1	MAINTENANCE DATA	9 - 2
9.1.1	Checking the Status of Troubles	9 - 2
9.1.2	Checking the NC Information	9 - 3
9.1.3	Display of Alarm Information	9 - 5
9.1.4	Cause of Alarm and Corrective Action	9 - 6
9.1.5	Troubleshooting (1)	9 - 7
9.1.6	Troubleshooting (2)	9 - 17
9.1.7	Alarms Not Indicated by Alarm Numbers	9 - 23

9.1 MAINTENANCE DATA

To locate the cause of problems or when contacting your Yaskawa representative for advice, it is very important that users precisely understand the actual situation. To minimize the downtime, check the following points precisely.



CAUTION

- When an alarm occurs, eliminate its cause and confirm safety before resetting it. Failure to observe this caution could result in malfunction.
- For details on trouble relating to the machine-related sequence, refer to the manual issued by the machine tool builder.

9.1.1 Checking the Status of Troubles

(1) Understanding the Situation

To make clear the status of troubles, check the following items first.

- Type of operation that causes a trouble.
Do other types of operation not cause troubles?
- Details of troubles.
How, frequency (always or sometimes), and when.
- Unusual situation when the trouble occurred.
Was there an unusual external occurrence such as power failure or lightning when the trouble occurred?
- Timing of trouble occurrence.
Had the trouble occurred during or after the operation of the keys or in a specific operation mode?

(2) Check Items

(a) Troubles related with axis feed and spindle drive

Check the following items.

- Indication of the LEDs on the drive unit
- Fuses and breakers
- Timing of trouble occurrence – when the power is turned ON, during acceleration, during deceleration, or during fixed speed spindle rotation, etc.?

(b) Troubles related with part program

Record the program block data, offset data, workpiece coordinate system offset data, coordinate system setting data, etc.

9.1.2 Checking the NC Information

Independent of the contents of the troubles, the following information must be checked.

(1) Hardware Environment

- Machine tool builder's name
- Delivery date of machine tool
- Type and model name of the machine tool
- Type and model name of the NC and units

(Example)

NC unit	YASNAC J300L
Servo drive	CACR-IR05SE
Servo motor	USAGED-05A
Spindle drive	VS-626 M5
Spindle motor	UAASKA-08CA3

(2) NC System Software

YASNAC J300s software is managed by the system numbers.

(a) System number (NC: □□□□□-□□)

The system number refers to the system software number which consists of five integer digits and a two-digit revision number. The system number of the basic software of the NC is displayed at the start-up screen which is displayed when the power is turned ON.

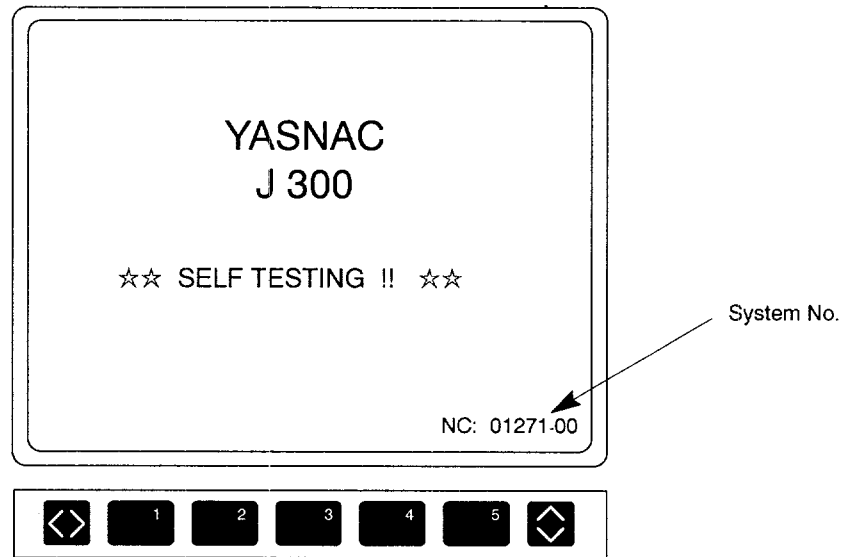

Fig. 9.1 Start-up Screen

Note that optional software also has individual system numbers - communication module, PLC ladder, ACGC applications, etc.

(b) Calling the system number display screen

Follow the procedure indicated below to call the system number display screen.

- ① Press the [MAINT] process key on the NC operation panel.
- ② Press the FUNCTION SELECT key in the function selection mode, and the function soft-key as shown in Fig. 9.2 is displayed.

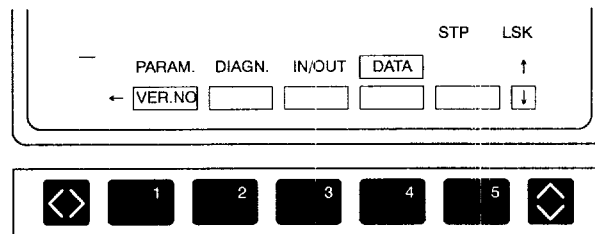

Fig. 9.2

- ③ Press the [VER.NO] (f1) function soft-key and the system number display screen is displayed.

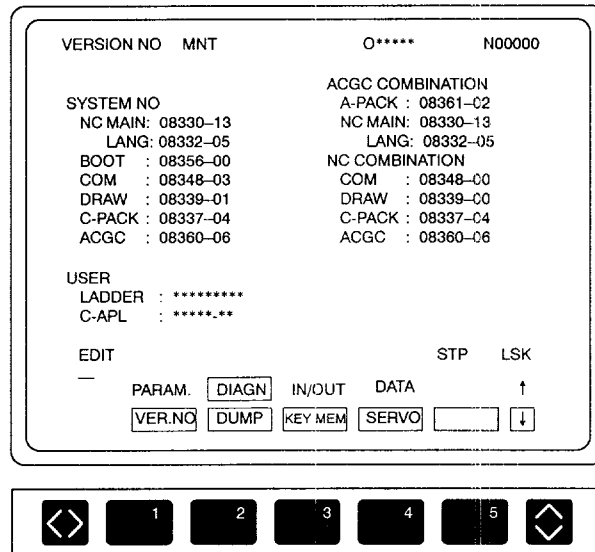

Fig. 9.3 System Number Display Screen

9.1.3 Display of Alarm Information

If an alarm occurs, the alarm number and comment of the alarm of the top priority is displayed in the normal display area disregarding the selected mode and the screen. For the procedure to follow to display the alarm information, refer to 7.2, "ALARM DISPLAY JOB".

9.1.4 Cause of Alarm and Corrective Action

The following shows the classification of YASNAC J300 alarms.

Table 9.1 Alarm Numbers and Classification

No.	Contents	Stop Mode	Output	How to Reset
0000 to 0049	Errors related to edit and operation Occurring in the background mode also.	Block stop	Input error alarm	Reset
0050 to 0099	Errors related to edit and operation Not occurring in the background mode.	Block stop	Input error alarm	Reset Power OFF for #0050 and #0051
0100 to 0499	Program error	Block stop	Input error alarm	Reset
1000 to 1099	Program error DNC, COMS total, etc.	Block stop	Input error alarm	Reset
2000 to 2199	Machine related error OT, reference point return, machine ready, in-position, etc.	Stop after deceleration, or immediate stop	Alarm	Reset operation after removing the cause. With the alarm caused by the machine ready signal, if it occurs in the first pow- er ON operation, it is automatically reset.
3000 to 3299	Servo and spindle related alarm ESP, CPU mutual monitoring	Immediate stop, or servo OFF	Alarm	Reset after removing the cause. With the SVOFF alarm, it is automatical- ly reset by the SVON.
8000 to 8049	Memory check error Watchdog timer error Offline error	Immediate stop, or servo OFF	Alarm	For maintenance CPU halt Switching to the special maintenance screen
9000 to 9049	Error occurring in background edit- ing (basically the same as with 0000 to 0049)	Not stopped	Background error output	Reset or with reset soft-key
No number indication BAT indication BAT. AXIS	Battery error Encoder alarm	Not stopped	No output	Changing the battery
No number indication Warning message	Key operation error, edit operation error (not serious operation error)	Not stopped	Warning	Next key operation

9.1.5 Troubleshooting (1)

(1) Alarm Nos.: 0010 and 0011 (Parity Error)

Table 9.2 Troubleshooting – Alarm Nos.: 0010 and 0011 (Parity Error)

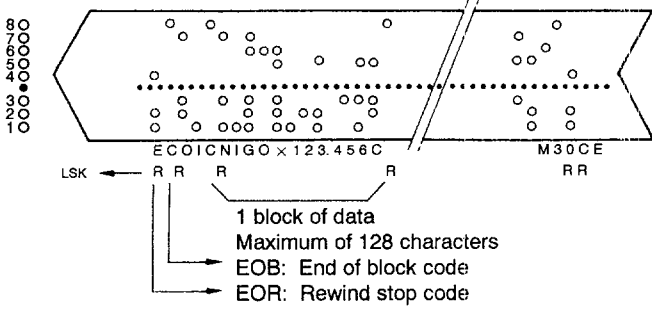
Alarm No.	Cause	Check Item	Countermeasures
0010	TH error	<ul style="list-style-type: none"> In the tape mode operation. Check the number of punched holes for each character. An alarm occurs in the following cases: EIA code: An even number of holes ISO code: An odd number of holes <The following explanation is given assuming the EIA code.> 	<ul style="list-style-type: none"> Clean the tape reader. Check the tape for problems. If the punched hole is faulty or fluffy, change the tape. If the tape reader is faulty, change the tape reader.
0011	TV error	<ul style="list-style-type: none"> In the memory or edit mode operation Check the machining program storage area. 	<p>If the JANCD-JP01 board or an expansion board (JANCD-JMM01) is faulty, change the faulty board.</p>
0011	TV error	<ul style="list-style-type: none"> In the tape mode operation Check the tape if TV check is allowed. (The number of characters in a block must be even, including the EOB code.) 	<p>If the tape for which TV check is not allowed is used, change the setting for the parameters to turn OFF the TV check function. pm0004 D1 = 0 pm0006 D1 = 0 Or correct the tape so that the TV check is allowed.</p>

(2) Alarm Nos.: 0016, 0017, 0018, 9016, 9017, 9018 (RS-232C Error)

Table 9.3 Countermeasures – Alarm Nos.: 0016, 0017, 0018, 9016, 9017, 9018 (RS-232C Error)

Alarm No.	Cause	Check Item	Countermeasures
0016 9016	Transmission error	Check if the RS-232C transmission error (high noise level) occurs.	Check the grounding of cables.
0017 9017	Overrun	Check if more than 10 characters have been read after the output of the RS-232C interface stop code.	
0018 9018	Line selection	Check the RS-232C interface line selection for error.	<ul style="list-style-type: none"> • Check the RS-232C device specifications. • Check the setting for parameters.

Note: Nos. 0016, 0017, and 0018 are for online and Nos. 9016, 9017, and 9018 are for offline.

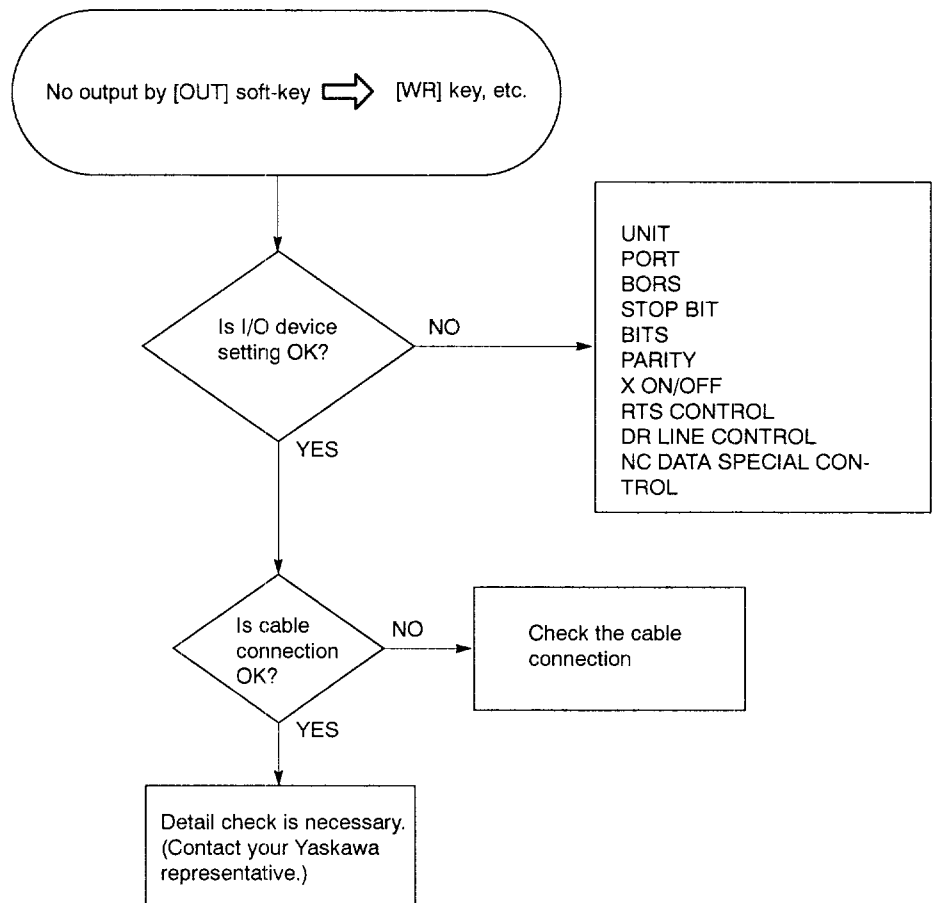

Fig. 9.4 RS-232C Interface Troubleshooting Flowchart

(a) Setting the interface

When the RS-232C interface is used, baud rate, stop bit length, and use of control code must be set in the following procedure.

- ① Press the [MAINT] process key on the NC operation panel.
- ② Press the [IN/OUT] (f3) job soft-key.
- ③ Press the [RS232C] (f5) function soft-key to select the I/O device setting function.
- ④ Set the necessary RS-232C communication parameters.

PROGRAM I/O	MNT	O12345	N12345
I/O UNIT SET		IN	OUT
UNIT		RS232C	RS232C
PORT		NO.1	NO.2
BPS		4800	9600
STOP BIT		2BIT	1BIT
BITS		8BITS	7BITS
PARITY		OFF	EVEN
X ON/OFF		ON	OFF
RTS CONTROL		ON	OFF
DR CNTRL		ON	OFF
NC CNTRL		ON	OFF
MEM			STP LSK
—	EDIT	DIR	IN/OUT
	1200	2400	4800
			9600
			SELECT
			↑
			↓

◀	1	2	3	4	5	▶
---	---	---	---	---	---	---

Fig. 9.5 Setting for the Serial Interface

(b) Setting for the serial interface

For the serial interface, setting is possible for the following parameters.

Table 9.4 Serial Interface Setting

Menu Item	Input	Output
UNIT (device)	YE tape reader	YE tape puncher
	General-purpose RS-232C	General-purpose RS-232C
PORT	NO. 1	NO. 2
	NO. 1	NO. 2
BORS (baud rate)	75	75
	150	150
	300	300
	600	600
	1200	1200
	2400	2400
	4800	4800
	9600	9600
STOP BIT	1 bit	1 bit
	2 bits	2 bits
BITS (bit length)	7 bits	7 bits
	8 bits	8 bits
PARITY (parity scheme)	Even parity	Even parity
	Odd parity	Odd parity
	None	None
X ON/OFF (control code)	Supported	Supported
	None	None
RTS CONTROL	Supported	Supported
	None	None
PARITY ISO	Supported	Supported
	None	None

Note: Although two RS-232C ports are provided, these two ports cannot be used at the same time. For these two ports, setting can be made independently from each other.

(c) Selecting the input/output port

When changing the port to be used, follow the procedure indicated below.

- ① Move the cursor to the required port number.
- ② Press the FUNCTION SELECT key.
- ③ Press the soft-key corresponding to the item to be set, and the data are written to the cursor position.

Tables 9.5 and 9.6 show the RS-232C voltage level and the interface connection cable, respectively.

Table 9.5 RS-232C Voltage Level

	V0 < -3V	V0 < +3V
Function	OFF	ON
Signal Status	Mark	Space
Logic	1	0

Table 9.6 RS-232C Interface Connection Cable (A)

NC Side (DB-9P)			Connection	Device Side
Symbol	Signal Name	Pin No.		Symbol
FG	Frame grounding	1		FG
SD	Send data	2		SD
RD	Receive data	3		RD
RS	Request to send	4		RS
CS	Clear to send	5		CS
DR	Data set ready	6		DR
SG	Signal grounding	7		SG
ER	Data terminal ready	9		IO BUSY
				ER

(d) Example of port connection

An example of connection at RS-232C port is indicated below. Fig. 9.6 shows the connection of standard RS-232C tape reader.

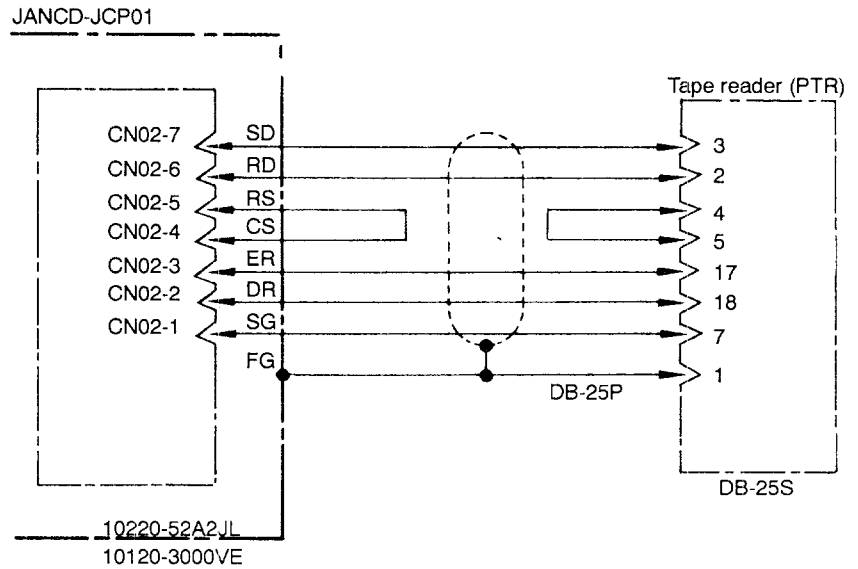

Note: Cable length between the tape reader and the main board (JANCD-JCP01) must be within 3 m.
If a cable longer than 3 m must be used, contact your Yaskawa representative.

Fig. 9.6 Connection of No. 1 RS-232C Port

(3) Alarm No.: 1099 (High Temperature)

Table 9.7 Countermeasures – Alarm No.: 1099 (High Temperature)

Cause	Check Item	Countermeasures
Ambient temperature of the NC rack exceeded the specified value* due to the failure of cooling fan. *: 70°C ± 3°C when measured above CPS-18.	<ul style="list-style-type: none"> • Open the NC unit door to check if the cooling fan is operating correctly. • Make sure that air is blowing out through the ventilation port of the cooling duct. • Make sure that the ventilation port of the cooling duct is not blocked. 	<ul style="list-style-type: none"> • If the fan is faulty, it is necessary to change it. Contact your Yaskawa representative. • If the cooling duct is blocked, remove interfering object and start the cooling fan.
Internal temperature of the power supply unit is high.	Allow the power supply unit to cool by turning OFF the power with the NC unit door opened. If the alarm occurs even after the power supply unit has been cooled for 30 minutes, the power supply unit will be faulty.	It is necessary to change the power supply unit. Contact your Yaskawa representative.
Ambient temperature of the NC unit is high*. *: Allowable temperature range for operation is 0 to 40°C.	<ul style="list-style-type: none"> • Measure ambient temperature. • If the NC unit is subject to direct sunlight, the NC unit temperature will exceed the allowable limit. 	This is not the failure of the NC unit. Remove the cause.

(4) Alarm Nos.: 2061 to 2068 (Reference Point Return Area Error)

Table 9.8 Troubleshooting – Alarm Nos.: 2061 to 2068
(Reference Point Return Area Error)

Cause	Check Item	Countermeasures
The reference point return start point is at the zero point side of the deceleration limit switch.	<p>Deceleration limit switch (DECLS) #3073 D0 (1st axis) #3073 D1 (2nd axis) #3073 D2 (3rd axis) #3073 D3 (4th axis) #3073 D4 (5th axis)</p> <p>Execute reference point return again while observing the I/O signal monitor screen.</p> <p>If reference point return is started from a point located at the reference point side of DECLS (point C) as shown below, an alarm occurs. Note: This error check is not made before the execution of manual reference point return after the power is turned ON.</p>	Return the axis to a position on the deceleration LS or away from it and, then, execute reference point return once again.
Approach feedrate is too fast.	Compare the setting for the approach feedrate parameter with the parameter list.	Change the setting for parameters pm2521 to pm2525 to an appropriate value.

(5) Alarm Nos.: 2071 to 2078, 2081 to 2088
(Reference Point Return Position Error)

Table 9.9 Troubleshooting – Alarm Nos.: 2071 to 2078, 2081 to 2088
(Reference Point Return Position Error)

Cause	Check Item	Countermeasures
Alarm in manual reference point return operation	Check if the error occurs every time.	Contact machine tool builder or your Yaskawa representative.
Alarm in automatic reference point return operation	G28: Check if the alarm occurs every time.	Contact machine tool builder or your Yaskawa representative.
	G27: Check the point specified in the program if it agrees with the zero point.	Review the program.

(6) Alarm Nos.: 2101 to 2108 (P-SET Error)

The P-SET alarm occurs if the error between the position specified in the program and the actual machine position is larger than the value set for parameters pm1321 (1st axis) to pm1325 (5th axis) in the following modes of operation.

At the completion of positioning in G00, G27, G28, G29, G30, etc., error detect ON (I/O monitor parameter #3004 D4 = 1), and G04 (dwell).

If error pulses have been accumulated, check the number of accumulated pulses on the error pulse display screen before contacting your Yaskawa representative.

(7) Alarm No.: 3000 (Servo Power Not Ready)

Table 9.10 Troubleshooting – Alarm No.: 3000 (Servo Power Not Ready)

Cause	Check Item	Countermeasures
Secondary power supply is not applied.	If the NC RESET switch, etc. is depressed after depressing the POWER ON button once, or after clearing the emergency stop or alarm state, the alarm message is displayed. This does not indicate the occurrence of alarm.	Press the POWER ON button again.
With the secondary power ON I/O input specification, the input is not turned ON. (For the automatic servo power ON)	Check the following on the I/O monitor screen: #3005 D0 = 1 (SVON) #3503 D0 = 1 (SVONS)	Contact your Yaskawa representative.
Emergency stop signal stays ON.	Check if alarm No. 3002 is displayed (#3503 D4 = 1) on the screen.	Reset the emergency stop input signal.
The secondary power ON signal is turned OFF due to some other alarm.	Check the alarm indication for other alarms.	Take appropriate measures by referring to the alarm code.

(8) Alarm No.: 3001 (Control Not Ready)

The NC executes self-diagnose after power ON. If positioning error checked during this self-diagnosis exceeds the values set for parameters pm1321 (1st axis) to pm1325 (5th axis), this alarm occurs.

Table 9.11 Troubleshooting – Alarm No.: 3001 (Control Not Ready)

Cause	Check Item	Countermeasures
Machine (axes) have moved.	Select the error pulse display screen from the present position display screen in the common process and check the error pulse value.	The machine tool has a problem. Contact the machine tool builder.
PG signal remains output.		PG or AC servo must be changed. Contact your Yaskawa representative.

9.1.6 Troubleshooting (2)

For the system equipped with the drive unit compatible with YENET1200, check is made by both the drive unit itself and the NC unit. If a fault is detected, the drive unit notifies the NC unit the alarm information in two systems.

The drive unit first gives the NC unit the information on the occurrence of an alarm (alarm No. 3101 to No. 3105 and No. 3201) and then the content of the alarm. The NC unit displays alarm No. 3100 when it receives the alarm information from drive units.

Therefore, three alarms usually occur if an error is detected with the drive unit. If fuse blown occurs with the X-axis servo unit, alarm No. 3100, No. 3101, and No. 3021 occur.

(1) Alarm Nos.: 3021 to 3025 (Fuse Blown)

The main circuit of the servo unit will be faulty.

The servo unit detects the error.

Contact your Yaskawa representative.

(2) Alarm Nos.: 3041 to 3045, and 3051 (Excessive Follow-up Error)

This alarm occurs if the follow-up error exceeds 120% of the error in rapid traverse (100%) operation.

The servo unit detects the alarm.

Improper gain adjustment is one of the reasons.

Contact your Yaskawa representative.

(3) Alarm Nos.: 3061 to 3065 (Overload)

This alarm occurs if the load exceeds the rated torque considerably.

The servo unit detects the error.

Review the cutting conditions. Contact your Yaskawa representative after checking whether the alarm occurs simply after turning the control power ON.

(4) Alarm Nos.: 3081 to 3085 and 3091 (Broken PG Cable)

The encoder signal cable or the encoder itself will be faulty.

The servo unit or the inverter detects the error.

Contact your Yaskawa representative.

(5) Alarm Nos.: 3101 to 3105 (Servo Alarm)

This alarm occurs when the NC unit detects the alarm signal output from the servo unit.

Check the contents of the alarm by displaying the servo alarm display screen (press [f2] of the alarm job in the common process.).

(6) Alarm Nos.: 3111 to 3115 (Servo Communication Alarm)

Probable causes of this alarm are broken YENET1200 communication cable, loose cable connection, and communication processing error.

The servo unit detects the alarm.

Contact your Yaskawa representative after making sure that the cable is securely connected.

(7) Alarm Nos.: 3121 to 3125 (Excessive Speed)

This alarm occurs if the motor speed exceeds 4950 r/min or the value set for the parameter.

The servo unit detects the alarm.

It is necessary to check whether the connection to the encoder is correct.

Contact your Yaskawa representative.

(8) Alarm Nos.: 3141 to 3145 (Overrun Prevention)

The encoder will be faulty.

The servo unit detects the alarm.

Contact your Yaskawa representative.

(9) Alarm Nos.: 3151 to 3155 (Phase Detection Error)

The encoder signal cable or the encoder itself will be faulty.

The servo unit detects the error.

Contact your Yaskawa representative.

(10) Alarm Nos.: 3161 to 3165 (Absolute Error)

This alarm occurs if the absolute value data cannot be received correctly in one to two seconds after turning ON the power to the encoder.

The servo unit detects the error.

The encoder or the servo unit will be faulty.

Contact your Yaskawa representative.

(11) Alarm Nos.: 3181 to 3185 (Absolute Position Error)

The number of feedback pulses is checked every turn of the encoder and this alarm occurs if there is an error in the counted number of pulses.

The servo unit detects the alarm.

The encoder or the servo unit will be faulty, or malfunction could have occurred due to noises.

Contact your Yaskawa representative.

(12) Alarm No.: 3201 (Inverter Alarm)

This alarm occurs when the NC unit detects the alarm signal output from the inverter.

Check the contents of the alarm by displaying the servo alarm display screen (press [f2] of the alarm job in the common process.).

(13) Alarm Nos.: 3281 to 3285, 3291 (YENET1200 command time-out)

This alarm occurs when the YENET1200 communication lines fail to get ready.

The NC units detects the alarm.

The servo unit or the inverter unit will be faulty.

Contact your Yaskawa representative.

(14) Alarm Nos.: 3301 to 3305 (Over Current)

The servo unit detects the alarm.

The servo unit will be faulty if the alarm occurs before the operation is started after turning the power ON.

If the alarm occurs during operation, ground fault of the motor will be the cause.

Contact your Yaskawa representative.

(15) Alarm Nos.: 3331 to 3335 (Over Voltage)

The servo unit detects the alarm.

If the alarm occurs when the power is turned ON to the spindle, the input voltage will be too high.

If the alarm occurs during motor operation, it is necessary to review the operation conditions; lower motor speed, for example.

If the alarm occurs when the servo control power is turned ON, the servo unit will be faulty.

Contact your Yaskawa representative.

(16) Alarm Nos.: 3351 to 3355 (Heat Sink Overheat)

This alarm occurs when the heat sink temperature is abnormally high.

The servo unit detects the alarm.

If this alarm occurs, turn OFF the power and allow the heat sink to cool. After that turn the power ON again.

If the alarm occurs immediately after turning the power ON, the servo unit will be faulty.

Contact your Yaskawa representative.

(17) Alarm Nos.: 3381 to 3385, 3391 (YENET1200 Communication Error)

This is a communication error between the NC unit and the servo unit or between the NC unit and the inverter unit; the NC unit detects the alarm when no answer is returned for the command output by the NC unit.

The servo unit or the inverter unit will be faulty, or the cable will not be connected securely.

Contact your Yaskawa representative.

(18) Alarm Nos.: 3401 to 3405 (Converter Alarm)

This alarm occurs due to the following reasons: blown fuse, regeneration alarm, open phase, or faulty board.

The servo unit detects the alarm.

Contact your Yaskawa representative.

(19) Alarm Nos.: 3411 to 3415 (Servo Unit Alarm)

This alarm occurs due to the following reasons: destroyed parameter setting, faulty current detector, encoder's battery alarm, memory error, or sensor error.

The servo unit detects the alarm.

The servo unit or the motor will be faulty.

Contact your Yaskawa representative.

(20) Alarm No.: 3421, 3422 (Inverter Unit Alarm)

This alarm occurs when the inverter detects an alarm other than converter alarm, broken PG cable, excessive follow-up error, and communication error.

Contact your Yaskawa representative.

(21) Alarm Nos.: 3425, 3426, 3431 to 3435 (YENET1200 Watchdog Error)

This alarm occurs when the NC unit detects the watchdog error with the inverter unit or the servo unit.

The inverter unit or the servo unit will be faulty.

Contact your Yaskawa representative.

(22) Alarm Nos.: 3441 to 3445 (Ground Fault)

This alarm occurs when the servo unit detects the alarm when the power is turned ON.

Motor insulation is faulty.

Contact your Yaskawa representative.

(23) Alarm No.: 3451 and 3452 (Follow-up Error)

This alarm occurs when the follow-up error exceeds the value set for the servo unit parameter.

The servo unit detects the alarm.

If this alarm occurs during axis feed over a long distance, it is necessary to either lower the command speed or increase the gain.

If the motor does not rotate, the servo unit will be faulty.

Contact your Yaskawa representative.

9.1.7 Alarms Not Indicated by Alarm Numbers

Troubles caused by abnormal functioning of the NC, but not indicated by an alarm number, and required countermeasures are indicated below. If the troubles cannot be cleared by following the procedure indicated below, contact the machine tool builder or your Yaskawa representative.

(1) Power Cannot be Turned ON

(a) Power is not supplied to the NC

- Check the SOURCE LED (green) of the DC power supply (CPS-18FB) in the CPU module if it is lit.
- Check the input AC power across CN03-1 and CN03-5 terminals of the DC power supply (CPS-18FB).

Specification: 200/220/230 VAC -15 to +10%, 50/60 Hz ± 2 Hz

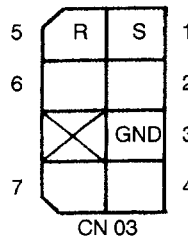

(b) Alarm LED on the DC power supply (CPS-18FB) is lit

Table 9.12 Alarm LEDs on DC power supply (CPS-18FB)

	Signal Name	Display	LED Color	Function and Cause
Normal	Power supply conditions	SOURCE	Green	Lit: Power is input. Not lit: Power is not input.
	Power ON status	POWER ON	Green	Lit: DC power is output.
Error indication	± 5 V error	± 5 V	Red	Lit: +5 V overvoltage or overcurrent
	+24 V error	+24 V	Red	Lit: +24 V overvoltage or overcurrent
	Overheat	OHT	Red	Lit: Overheat of components in the NC unit

Check the DC output voltage at CN01 terminals of the DC power supply (CPS-18FB).

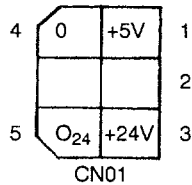

+5 V: Across CN01-1 and CN01-4
 +24 V: Across CN01-3 and CN01-5

(2) No Display is Given on the CRT

If nothing is displayed on the CRT, the CRT itself might be faulty, or the display circuit or connection cables might be faulty. When nothing is displayed even if the power can be turned ON to the NC, check the cable connection to the operation panel and also the connectors.

(3) Handle Mode Operation is Impossible

(a) Handle mode signal is not input

- Check the bit status of I/O monitor #3000.
 - D₂ = 1
 - Other bits (D₀, D₁, D₃ to D₇) = 0
- Check the mode display given in the normal display area on the screen.

(b) Axis selection signal is not input

- I/O monitor
 Check whether one of the following bits is ON.

#3070	
D ₀ = 1	1st axis
D ₁ = 1	2nd axis
D ₂ = 1	3rd axis
D ₃ = 1	4th axis
D ₄ = 1	5th axis

- No. 2 handle

Check whether one of the following bits is ON.

#3080	
D ₀ = 1	1st axis
D ₁ = 1	2nd axis
D ₂ = 1	3rd axis
D ₃ = 1	4th axis
D ₄ = 1	5th axis

- No. 3 handle

Check whether one of the following bits is ON.

#3081	
D ₀ = 1	1st axis
D ₁ = 1	2nd axis
D ₂ = 1	3rd axis
D ₃ = 1	4th axis
D ₄ = 1	5th axis

(c) There is no input to handle PG

- Check the input voltage (5 V) at the handle PG terminal.
- Check the handle PG signal cable connector if it is securely plugged in.

(d) Handle PG is faulty

Check the following (counter monitor) on the I/O screen if the values change according to the operation of the pulse handle.

#3037 (No. 1 handle)

#3038 (No. 2 handle)

#3039 (No. 3 handle)

(e) Other related parameters

Check the setting for the following parameters.

Maximum feedrate for handle operation	Parameter pm2860 (linear axis) Parameter pm2861 (rotary axis)
Acceleration/deceleration time constant for handle operation	Parameters pm2561 to pm2565
Pulse multiplication ratio of “× 100” is set (pm2003 D7 = 1)	Parameter pm2549

(4) Jog Operation is Impossible

(a) Jog mode signal is not input

Check the bit status of I/O monitor #3000.

D1 = 1

Other bits (D0, D2 to D7) = 0

(b) Axis move direction signal is not input.

Check the bit status of I/O monitor #3071 and #3072.

#3071		#3072	
D0	+1st axis	D0	-1st axis
D1	+2nd axis	D1	-2nd axis
D2	+3rd axis	D2	-3rd axis
D3	+4th axis	D3	-4th axis
D4	+5th axis	D4	-5th axis

- (c) Jog feedrate signal is not input, or job feedrate setting parameter is incorrect

Check the bit status on the I/O monitor screen whether it changes according to the operation of the JOG FEEDRATE switch, and also check if the setting for the parameters is correct.

Table 9.13 Jog Feedrate

Step	I/O Monitor #3002					Jog Feedrate
	D4	D3	D2	D1	D0	
	JV16	JV8	JV4	JV2	JV1	
1	0	0	0	0	0	Set for parameter pm2400
2	0	0	0	0	1	Set for parameter pm2401
3	0	0	0	1	0	Set for parameter pm2402
4	0	0	0	1	1	Set for parameter pm2403
5	0	0	1	0	0	Set for parameter pm2404
6	0	0	1	0	1	Set for parameter pm2405
7	0	0	1	1	0	Set for parameter pm2406
8	0	0	1	1	1	Set for parameter pm2407
9	0	1	0	0	0	Set for parameter pm2408
10	0	1	0	0	1	Set for parameter pm2409
11	0	1	0	1	0	Set for parameter pm2410
12	0	1	0	1	1	Set for parameter pm2411
13	0	1	1	0	0	Set for parameter pm2412
14	0	1	1	0	1	Set for parameter pm2413
15	0	1	1	1	0	Set for parameter pm2414
16	0	1	1	1	1	Set for parameter pm2415
17	1	0	0	0	0	Set for parameter pm2416
18	1	0	0	0	1	Set for parameter pm2417
19	1	0	0	1	0	Set for parameter pm2418
20	1	0	0	1	1	Set for parameter pm2419
21	1	0	1	0	0	Set for parameter pm2420
22	1	0	1	0	1	Set for parameter pm2421
23	1	0	1	1	0	Set for parameter pm2422
24	1	0	1	1	1	Set for parameter pm2423
25	1	1	0	0	0	Set for parameter pm2424
26	1	1	0	0	1	Set for parameter pm2425
27	1	1	0	1	0	Set for parameter pm2426
28	1	1	0	1	1	Set for parameter pm2427
29	1	1	1	0	0	Set for parameter pm2428
30	1	1	1	0	1	Set for parameter pm2429
31	1	1	1	1	0	Set for parameter pm2430
32	1	1	1	1	1	Set for parameter pm2431

(d) Axis interlock is input

Check the bit status on the I/O monitor screen. If “0”, the corresponding axis cannot move.

#3078	
D ₀ = 1	1st axis
D ₁ = 1	2nd axis
D ₂ = 1	3rd axis
D ₃ = 1	4th axis
D ₄ = 1	5th axis

(e) Machine lock is ON

- ① Even when the machine lock function is ON, position display changes. Check the input of the machine lock switch (I/O monitor, #3006 D5 = 0). If “1”, the axes do not move.
- ② Check the internal toggle switch (parameter pm0000 D1 = 0). If “1”, the axes do not move.

(5) Manual Rapid Traverse is Impossible

(a) The rapid mode is not selected

Check the bit status of I/O monitor #3000.

D₀ = 1

Other bits (D₁ to D₇) = 0

(b) Axis move direction signal is not input.

Check the bit status of I/O monitor #3071 and #3072.

#3071		#3072	
D ₀	+1st axis	D ₀	-1st axis
D ₁	+2nd axis	D ₁	-2nd axis
D ₂	+3rd axis	D ₂	-3rd axis
D ₃	+4th axis	D ₃	-4th axis
D ₄	+5th axis	D ₄	-5th axis

(c) Rapid traverse override is not input

- Check the bit status on the I/O monitor screen whether it changes according to the operation of the RAPID TRAVERSE RATE OVERRIDE switch, and also check if the setting for the parameters is correct.

Table 9.14 Input Status and Rapid Traverse Rate

Input Status of #3003		Rapid Traverse Rate				
ROV2	ROV1	1st Axis	2nd Axis	3rd axis	4th axis	5th axis
1	1	Set for pm2801	Set for pm2802	Set for pm2803	Set for pm2804	Set for pm2805
1	0	[Setting for pm2801] × 1/2	[Setting for pm2802] × 1/2	[Setting for pm2803] × 1/2	[Setting for pm2804] × 1/2	[Setting for pm2805] × 1/2
0	1	[Setting for pm2801] × 1/4	[Setting for pm2802] × 1/4	[Setting for pm2803] × 1/4	[Setting for pm2804] × 1/4	[Setting for pm2805] × 1/4
0	0	F ₀ (set for pm2447)				

- For the 6-step specification (pm2000 D3 = 1), refer to Table 9.19.

Table 9.15

Input Status			Rapid Traverse Rate
ROV4	ROV2	ROV1	1st to 5th Axis
1	0	1	F ₂ (set for pm2449)
1	0	0	F ₁ (set for pm2448)
0	1	1	100%
0	1	0	50%
0	0	1	25%
0	0	0	F ₀ (set for pm2447)

(d) Parameter setting is incorrect

Refer to Tables 9.14 and 9.15.

(e) Axis interlock is input

Check the bit status on the I/O monitor screen. If “0”, the corresponding axis cannot move.

#3078	
D ₀ = 1	1st axis
D ₁ = 1	2nd axis
D ₂ = 1	3rd axis
D ₃ = 1	4th axis
D ₄ = 1	5th axis

(f) Machine lock is ON

- Even when the machine lock function is ON, position display changes. Check the input of the machine lock switch (I/O monitor, 3006 D5 = 0). If “1”, the axes do not move.
- Check the internal toggle switch (parameter pm0000 D1 = 0). If “1”, the axes do not move.

(6) Manual Reference Point Return is Incorrect

The following explanation is given assuming that jog and rapid traverse are executed correctly.

(a) Manual reference point return signal is not input

Check the I/O monitor #3007 D0. The status must be “1”.

Otherwise, the axis continues moving to OT at the same feedrate even if it reaches point A. See Fig. 9.7.

(b) Jog or rapid traverse mode is not selected

I/O monitor #3000 D0 or D1 must be “1”.

- (c) Deceleration limit switch signal is not input.

Check I/O monitor #3073 D0 to D4 while moving an axis at a slow feedrate such as in jog operation. Make sure feedrate changes as shown in Fig. 9.7.

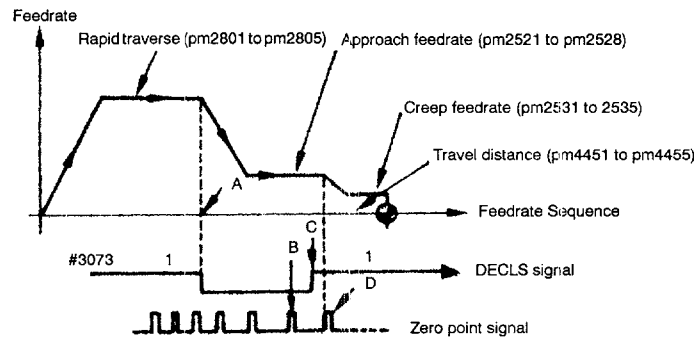

Fig. 9.7 Reference Point Return Control I/O Signals

- (d) Parameter setting is incorrect.

Check the setting for the related parameters against the parameter sheet by referring to Fig. 9.7.

- (e) Position of the dog for the deceleration limit switch is incorrect.

If the dog position is incorrect, the zero point could be shifted by one turn of the motor.

- (f) Others (loose coupling or dog)

If another adjustment is incorrect, zero point could be shifted at random.

(7) Cycle Start is Impossible

- (a) Cycle start signal is not input, or feed hold signal is open.

Check the I/O monitor #3003 D0 whether it goes “1” when the cycle start switch is pressed. In this case, the feed hold signal must be open; this can be confirmed by I/O monitor #3003 D1 = 1.

- (b) Start interlock signal is input.

If I/O monitor #3004 D2 = 1, cycle start is impossible.

- (c) The NC is in the reset status.

Normal status: I/O monitor #3500 D1 = 0

Also check the external reset signal status.

Normal status: I/O monitor #3004 D1 = 0

(8) G01, G02, or G03 Mode Operation is Impossible

- (a) The spindle is in the speed agreed status.

Check whether parameter pm1000 D7 = 1.

If it is “1”, check whether the spindle is in the speed agreed status by I/O monitor #3111.

- (b) FEEDRATE OVERRIDE switch setting is 0%.

Check the setting for I/O monitor #3111 D0 to D4 whether the setting is correct.

(c) In the dry run mode, setting for jog feedrate is incorrect.

Table 9.16

I/O Monitor #3040					Feedrate Override (Automatic Operation)
D4	D3	D2	D1	D0	
OV16	OV8	OV4	OV2	OV1	
0	0	0	0	0	0%
0	0	0	0	1	10%
0	0	0	1	0	20%
0	0	0	1	1	30%
0	0	1	0	0	40%
0	0	1	0	1	50%
0	0	1	1	0	60%
0	0	1	1	1	70%
0	1	0	0	0	80%
0	1	0	0	1	90%
0	1	0	1	0	100%
0	1	0	1	1	110%
0	1	1	0	0	120%
0	1	1	0	1	130%
0	1	1	1	0	140%
0	1	1	1	1	150%
1	0	0	0	0	160%
1	0	0	0	1	170%
1	0	0	1	0	180%
1	0	0	1	1	190%
1	0	1	0	0	200%
1	0	1	0	1	220%
1	0	1	1	0	240%
1	0	1	1	1	260%
1	1	0	0	0	280%
1	1	0	0	1	300%
1	1	0	1	0	340%
1	1	0	1	1	380%
1	1	1	0	0	420%
1	1	1	0	1	460%
1	1	1	1	0	500%
1	1	1	1	1	540%

(d) Start interlock signal is input.

If I/O monitor #3004 D2 = 1, start interlock is ON.

Normal: #3004 D2 = 0

(e) Axis interlock is input.

Check I/O monitor #3087 D0 to D4.

Normal: #3078 D0 to D4 = 1

(f) Setting of the servo system is incorrect.

Check whether the axes can be moved manually.

(9) Spindle Rotation is Impossible

(a) Error in a program (no S command, or no spindle start M code)

Check the contents of the program on the [RUN] screen.

(b) Start signal has not been input.

Check the output signals (#1100s) on the I/O monitor screen.

(c) Spindle rotation command has not been output.

Check #3654 to #3656 on the I/O monitor screen.

(d) The spindle drive is in the alarm status.

Check the alarm indication of the spindle drive.

(e) Combination of GRS and GSC is incorrect, or "0" is input for parameter pm1412 or pm1413.

Check I/O monitor #3110 by referring to Table 9.21.

Table 9.17 Input of GRS and GSC and S4-digit Command Analog Voltage

I/O Monitor #3110		S4-digit Command Analog Voltage
D7	D6	
GRS Input	GSC Input	
0	0	Voltage corresponding to the spindle speed specified in the NC program.
0	1	Voltage corresponding to parameter pm1412
1	0	Voltage corresponding to parameter pm1413
1	1	0 V

Note: If "1" is set for parameter pm1000 D5, SSTP input is reversed.

- (f) Setting for the parameters related to spindle operation is incorrect.

Check the setting for the related parameters.

#3110 D0	GR1
#3110 D1	GR2
#3110 D2	GR3
#3110 D3	GR4

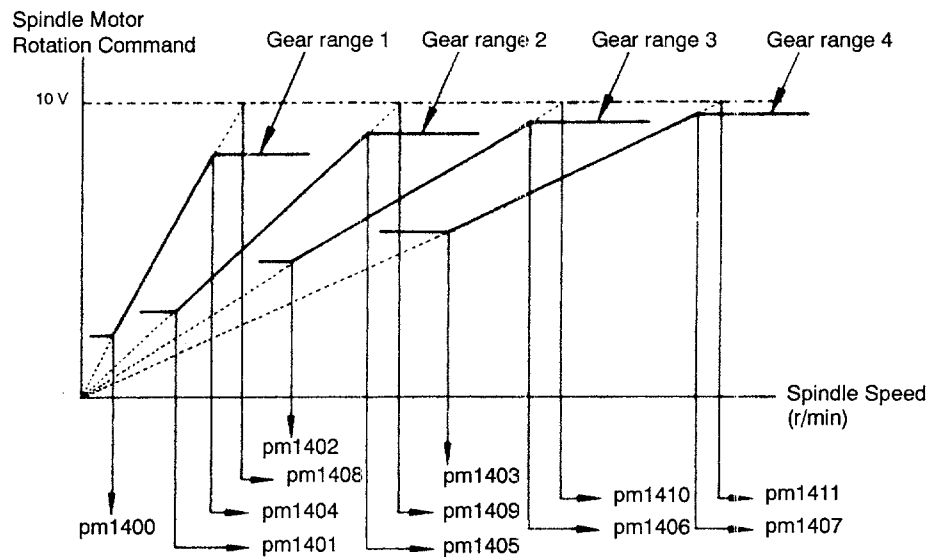

Fig. 9.8

(10) FIN Wait Status after Execution of Spindle Related Commands

If sequence processing is interrupted waiting for a signal, the NC enters the FIN wait status.

- (a) Spindle speed agree signal is not input.

If the NC enters this status after the execution of such as “M03 S100” commands, check whether #3111 D6 = 1 (waiting for FIN).

Check the I/O signals of #1000s at the I/O section by referring to the ladder chart supplied by the machine tool builder.

(b) Spindle zero speed signal is not input.

If the NC enters this status after the execution of “M05” command, check the I/O signals of #1000s at the I/O section by referring to the ladder chart supplied by the machine tool builder.

(c) Others

If the NC enters this status after the execution of “M19” or “M20” (spindle orientation command), check the I/O signals related with spindle orientation by referring to the ladder chart supplied by the machine tool builder.

(11) Edit Operation is Impossible

(a) The edit lock signal is input.

Check I/O monitor #3007 D2.

Normal: #3007 D2 = 0

If “#3007 D2 = 1”, program edit is impossible.

(b) Edit lock is set by the parameter (pm0000 D7).

Set “pm0000 D7 = 0” to cancel the edit lock setting.

(c) Others

- The corresponding alarm message is displayed.

OVER MEM CAP !
TOO MANY PROGS !
ALREADY IN !

- Delete unnecessary programs and edit the program again.

(12) Skip Function (G31) Failure

(a) The skip signal has not been input.

① Check ON/OFF status of the skip signals by checking the I/O monitor #3514 D0 to D2.

② Check the operation of proximity switches, etc.

(b) Parameter setting is incorrect.

- Check the setting for parameter pm2001 D0. If the setting for pm2440 is “0” while “pm2001 D0 = 1”, an axis does not move.

pm2001 D0 = 1	Feedrate in the skip feed mode (G31) is the feedrate set for parameter pm2440.
pm2001 D0 = 0	Feedrate in the skip feed mode (G31) is the feedrate specified with an F code.

- Check the setting for parameters pm5011 D0 to D2.

Set the signal status at the start of the processing when the SKIP signal is input.

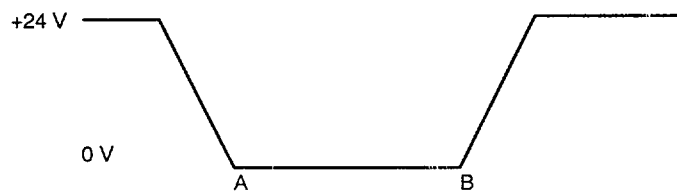

Fig. 9.9

- If “0”, processing starts at the point where 24 V falls to 0 V.
- After changing the setting, be sure to turn OFF the power once and turn it ON again.
- Check the setting for parameters pm5010 D0 to D2
The setting for this parameter determines ENABLE/DISABLE of the control circuit for the “SKIP” input.
 - Set “1” to use the skip function.
 - After changing the setting for this parameter always turn OFF the power once and then turn it ON again.

(13) Tape Mode Operation is Impossible

(a) Mode selection signal is incorrect.

Check the bit status of I/O monitor #3000.

D4 = 1

Other bits (D0 to D3, D5 to D7) = 0

(b) Setting at the tape reader is incorrect.

Check the setting made at taper reader model 2801 B-2. Refer to the table indicated below.

DIP Switch (DS)						Reading Speed	Transmission Speed (bps)	Auto/Self-check	Input Control
PTR Reading Speed		Transmission Speed		Input Control Selection	Self-check				
S1	S2	B1	B2	C/L	STS	char/s			
ON*	OFF	OFF	ON	ON	OFF	270	4800	AUTO	
ON	ON				OFF	300		AUTO	
OFF	OFF				OFF	200		AUTO	
		ON	ON		OFF		9600	AUTO	
		ON	OFF		OFF		2400	AUTO	
		OFF	OFF		OFF		1200	AUTO	
					ON			Self-check	
				ON					Code control
				OFF					Line control

Note: * Standard setting

Arrangement of DIP switches (standard setting)

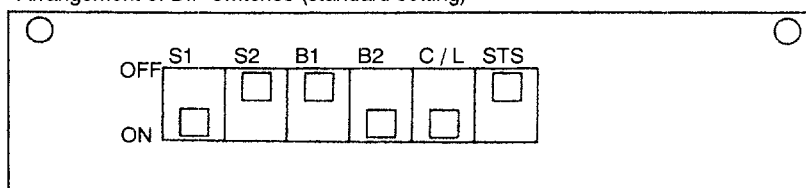

Fig. 9.10 Setting for Tape Reader

(c) Loose contact

Make sure that the cable connectors are securely connected.

(d) Faulty tape reader

- If the tape does not move even when the FEED switch is pressed, change the tape reader.
- If the red LED in the tape reader is not lit (power is not supplied to the taper reader, or tape reader is faulty.), change the tape reader.
- Check the tape holder.

(e) Power supply (EYG30/55GTL) for tape reader is faulty.

- Check if 200 V is input to the power supply.
- Check if 5 V and 24 V are correctly output.

APPENDIX 1

A1

LIST OF NC INPUT/OUTPUT SIGNALS

Appendix 1 describes the diagnosis numbers of the input/output signals between the NC and the PLC.

1.1	INPUT SIGNALS (PLC → NC)	A1 - 2
1.1.1	Operation Mode Control	A1 - 2
1.1.2	CNC Part Program Execution Control	A1 - 4
1.1.3	Servo Axis Control	A1 - 5
1.1.4	No. 1 Spindle Control	A1 - 7
1.1.5	No. 2 Spindle Control	A1 - 8
1.1.6	YENET1200 Compatible Inverter Control	A1 - 9
1.2	OUTPUT SIGNALS (NC → PLC)	A1 - 10
1.2.1	Operation Mode Control	A1 - 10
1.2.2	NC Part Program Execution Control	A1 - 12
1.2.3	Servo Axis Control	A1 - 14
1.2.4	No. 1 Spindle Control	A1 - 17
1.2.5	No. 2 Spindle Control	A1 - 18
1.2.6	YENET1200 Compatible Inverter Control	A1 - 19
1.2.7	Axis Variable Data	A1 - 20

APPENDIX 1.1 INPUT SIGNALS (PLC → NC)

1.1.1 Operation Mode Control

A1

Appendix Table 1.1 Operation Mode Control Signals

	7	6	5	4	3	2	1	0
#3000	EDT	MEM	MDI	TP	STP	H	JOG	RT
	Operation Mode							
#3002	MP4	MP2	MP1	JV16	JV8	JV4	JV2	JV1
	Manual Pulse Multiply			Jog Feedrate				
#3003		ROV4	ROV2	ROV1			* SP	ST
	Rapid Traverse Override						Stop	Cycle Start
#3004			CDZ	SMZ		STLK	ERS	MRD
			Thread Chamfering	Error Detect ON		Start Interlock	External Reset	Machine Ready
#3005	ERR2	ERR1	ERR0			CJNT	EXTC	SVON
	Servo OFF	Decel. and Stop	Block Stop			C-axis Joint	Time Count	External Servo ON
	External Error Detection							
#3006	AFL	MLK		DRN	PRST		ABS	SBK
	MST Function Lock	Machine Lock		Dry Run	Program Restart		Manual Absolute	Single-Block
#3007	SRN				EXT CLR	EDT LK	ZRN2	ZRN
	Setup Point Return				Ext. Position Data Clear	Edit Lock	Second Reference Point Return	Reference Point Return
#3008					PST	CPRN	HOFS	
					Present Position Data Save	Interruption Point Return	Auto Mode Handle Offset	
#3009								
#3011	FSED CLR	FSED CH	FSED MEM	FSED M	ECLM	EOUT	EVER	EIN
	FS Automatic Edit				External I/O Verify			
#3012							WOM	WOP
							Tool Wear Offset	
#3017	DSPP3	DSPP2	DSPP1	DSPP0	DSPJ3	DSPJ2	DSPJ1	DSPJ0
	Ext. Screen Change (Process Designation)				Ext. Screen Change (Job Designation)			

Appendix Table 1.1 Operation Mode Control (cont'd)

	7	6	5	4	3	2	1	0
#3018				DSPCHG	DSPF3	DSPF2	DSPF1	DSPF0
				Ext. Screen Change Strobe Signal	Ext. Screen Change (Function Designation)			
#3020						IS1		
						Setup Request		
#3023	TNO7	TNO6	TNO5	TNO4	TNO3	TNO2	TNO1	TNO0
	Tool No.							
#3024							TNO9	TNO8
							Tool No.	
#3025	TGN7	TGN6	TGN5	TGN4	TGN3	TGN2	TGN1	TGN0
	Tool Group No. (Tool Life Control)							
#3028					TLCNT		TLSKP	TLRST
					Tool Life Control Count Ignore		Tool Life Management Control	
#3030	ED7	ED6	ED5	ED4	ED3	ED2	ED1	ED0
	Ext. Data Input							
#3031	ED15	ED14	ED13	ED12	ED11	ED10	ED9	ED8
	Ext. Data Input							
#3032	ED23	ED22	ED21	ED20	ED19	ED18	ED17	ED16
	Ext. Data Input							
#3033	ED31	ED30	ED29	ED28	ED27	ED26	ED25	ED24
	Ext. Data Input							
#3034	EDCL	EDAS2	EDAS1	EDAS0	EDSD	EDSC	EDSB	EDSA
	Ext. Data Input							
#3037	1HP7	1HP6	1HP5	1HP4	1HP3	1HP2	1HP1	1HP0
	PG Pulse Input Monitor							

A1

A1

Appendix Table 1:1 Operation Mode Control (cont'd)

	7	6	5	4	3	2	1	0
#3038	2HP7	2HP6	2HP5	2HP4	2HP3	2HP2	2HP1	2HP0
PG Pulse Input Monitor								
#3039	3HP7	3HP6	3HP5	3HP4	3HP3	3HP2	3HP1	3HP0
PG Pulse Input Monitor								

1.1.2 CNC Part Program Execution Control

Table 1.2 CNC Part Program Execution Control

	7	6	5	4	3	2	1	0	
#3040	OVC	OPT	BDT	OV16	OV8	OV4	OV2	OV1	
Override Cancel	Optional Stop	Block Delete	Feedrate Override						
#3041					FIN	RWDH	RWD	EOP	
					MT Function Fin.	High-speed Rewind	Rewind	End of Program	
#3042	BDT9	BDT8	BDT7	BDT6	BDT5	BDT4	BDT3	BDT2	
Block Delete									
#3045	SSEL1								
Rotary Tool Selection Input									
#3046	UI7	UI6	UI5	UI4	UI3	UI2	UI1	UI0	
Macroprogram Input									
#3047	UI15	UI14	UI13	UI12	UI11	UI10	UI9	UI8	
Macroprogram Input									
#3048	UI23	UI22	UI21	UI20	UI19	UI18	UI17	UI16	
Macroprogram Input									
#3049	UI31	UI30	UI29	UI28	UI27	UI26	UI25	UI24	
Macroprogram Input									

1.1.3 Servo Axis Control

Appendix Table 1.3 Servo Axis Control

	7	6	5	4	3	2	1	0
#3070				H5	H4	H3	H2	H1
				Pulse Handle Axis Selection				
#3071				+5	+4	+3	+2	+1
				Manual Feed Axis/Direction Selection				
#3072				-5	-4	-3	-2	-1
				Manual Feed Axis/Direction Selection				
#3073				* DC5	* DC4	* DC3	* DC2	* DC1
				Reference Point Return Decel. LS				
#3074				* +OT5	* +OT4	* +OT3	* +OT2	* +OT1
				Overtravel LS				
#3075				* -OT5	* -OT4	* -OT3	* -OT2	* -OT1
				Overtravel LS				
#3076				MLK5	MLK4	MLK3	MLK2	MLK1
				Machine Lock Axis				
#3078				* IT5	* IT4	* IT3	* IT2	* IT1
				Axis Interlock				
#3079		* CISVOF		* SVOF5	* SVOF4	* SVOF3	* SVOF2	* SVOF1
		C-axis Servo OFF		Axis Servo OFF				
#3080				2H5	2H4	2H3	2H2	2H1
				No. 2 Pulse Handle Axis Selection				
#3081				3H5	3H4	3H3	3H2	3H1
				No. 3 Pulse Handle Axis Selection				

A1

Appendix Table 1.3 Servo Axis Control (cont'd)

	7	6	5	4	3	2	1	0
#3083				DTCH5	DTCH4	DTCH3	DTCH2	DTCH1
				Axis Disconnection Designation				
#3084				TRQ1-5	TRQ1-4	TRQ1-3	TRQ1-2	TRQ1-1
				Designation of Servo Axis Torque Limit Input (1st Stage) Axis				
#3085				TRQ2-5	TRQ2-4	TRQ2-3	TRQ2-2	TRQ2-1
				Designation of Servo Axis Torque Limit Input (2nd Stage) Axis				

1.1.4 No. 1 Spindle Control

Appendix Table 1.4 No. 1 Spindle Control

	7	6	5	4	3	2	1
#3110	GRS Gear Shift	GSC Fixed Speed	SSTP S Command Output Stop	SINV S Analog Output Reverse	GR4	GR3	GR2 GR1
					Spindle Gear Range		
#3111	SFIN S Function Fin.	SAGR Spindle Speed Agreed		SPE	SPD	SPC	SPB SPA
				Spindle Speed Override			
#3112	SDI7	SDI6	SDI5	SDI4	SDI3	SDI2	SDI1 SDI0
S Command Binary							
#3113	SDI15	SDI14	SDI13	SDI12	SDI11	SDI10	SDI9 SDI8
S Command Binary							
#3114	SDI23	SDI22	SDI21	SDI20	SDI19	SDI18	SDI17 SDI16
S Command Binary							
#3115							S2COP S1COP
						Spindle Linkage Input	
#3116						CSVONS Spindle Servo ON Copy	SPMODES Spindle Control Mode Copy
							CAXREQ C-axis Switching Request
#3117				SLPC Spindle Position Loop Mode	SIDX CUT	SIDXI	SIDX INC SIDX
				Spindle Index			
#3118	SID7	SID6	SID5	SID4	SID3	SID2	SID1 SID0
Spindle Index							
#3119					SID11	SID10	SID9 SID8
					Spindle Index		

1.1.5 No. 2 Spindle Control

Table 1.5 No. 2 Spindle Control

	7	6	5	4	3	2	1	0
#3120	GRS-2 Gear Shift	GSC-2 Fixed Speed	SSTP-2 S Command Output Stop	SINV-2 S Analog Output Reverse	GR4-2	GR3-2	GR2-2	GR1-2
					Spindle Gear Range			
#3121	S Function Fin.	SAGR-2 Spindle Speed Agreed		SPE-2	SPD-2	SPC-2	SPB-2	SPA-2
					Spindle Speed Override			
#3122	SDI7-2	SDI6-2	SDI5-2	SDI4-2	SDI3-2	SDI2-2	SDI1-2	SDI0-2
	S Command Binary							
#3123	SDI15-2	SDI14-2	SDI13-2	SDI12-2	SDI11-2	SDI10-2	SDI9-2	SDI8-2
	S Command Binary							
#3124	SDI23-2	SDI22-2	SDI21-2	SDI20-2	SDI19-2	SDI18-2	SDI17-2	SDI16-2
	S Command Binary							
#3125							S2COP-2	S1COP-2
							Spindle Linkage Input	
#3126						CSVONS-2 Spindle Servo ON Copy	SPMODES-2 Spindle Control Mode Copy	CAXREQ-2 C-axis Switching Request
#3127				SLPC-2 Spindle Position Loop Mode	SIDXCUT-2	SIDXI-2	SIDXINC-2	SIDX-2
					Spindle Index			
#3128	SID7-2	SID6-2	SID5-2	SID4-2	SID3-2	SID2-2	SID1-2	SID0-2
					Spindle Index			
#3129					SID11-2	SID10-2	SID9-2	SID8-2
					Spindle Index			

1.1.6 YENET1200 Compatible Inverter Control

Table 1.6 YENET1200 Compatible Inverter Control

	7	6	5	4	3	2	1	
#3200	SPRST-1	SPSSC-1	SPTLL-1	SPTLH-1	SPREV-1	SPFWD-1	SPEMG-1	SPRDY-1
	Alarm Reset	Soft-start Cancel	Torque Limit L	Torque Limit H	Reverse Rotation	Forward Rotation	Emergency Stop	Operation Ready
Signals for YENET1200 Compatible Inverter (No. 1 Spindle)								
#3201			SPDAS-1	SPMGR-1	SPLGR-1	SPORT-1	SPPPI-1	SPCHW-1
			Speed Command Selection	M Gear Selection	L Gear Selection	Orientation	Speed Controller P-PI Switchover	Winding Switchover
Signals for YENET1200 Compatible Inverter (No. 1 Spindle)								
#3202	SPRST-2	SPSSC-2	SPTLL-2	SPTLH-2	SPREV-2	SPFWD-2	SPEMG-2	SPRDY-2
Signals for YENET1200 Compatible Inverter (No. 2 Spindle)								
#3203			SPDAS-2	SPMGR-2	SPLGR-2	SPORT-2	SPPPI-2	SPCHW-2
Signals for YENET1200 Compatible Inverter (No. 2 Spindle)								

APPENDIX 1.2 OUTPUT SIGNALS (NC → PLC)

1.2.1 Operation Mode Control

A1

Appendix Table 1.7 Operation Mode Control

	7	6	5	4	3	2	1	0
#3500			BGEDES	WARN S	IERS	* ESP S	RSTS	ALMS
			Output – BG Edit Error State	Output – Warning State	Output – Input Error State	Output – EMG. Stop State	Output – Reset State	Output – Alarm/Error State
#3501						EDTS	AUTO	MAN
						Output – Editing	Output – Auto Mode Selected	Output – Manual Mode Selected
#3502	ONPB	OHT	TO	BALM	SSW3	SSW2	SSW1	SSW0
	Output – NC Control Monitor				Output – System No. Switch Monitor			
#3503		SVMXRST	PWLOST	ESP	SVALM		* BK	SVON S
		SVMX Reset Output	Power Lost	Emergency Stop Output	Servo/Spindle Unit Alarm Output		Output – Brake ON Monitor	Output – Servo ON Monitor
#3504		ES END	ER END		SMZS	FSED MC	FSED CE	FSED S
	External Data Input Function Fin. Output				Error Detect ON Output	Output – FS Auto Edit Monitor		
#3505			TLSKPF	TLRSTF	TLCHB	TLCH	CPRNS	
			Tool Skip Finish	Tool Reset Finish	New Tool Selection	Output – Life Control Tool Change	Output – Operation Interrupted Point Return Finish	
#3506					SSWS3	SSWS2	SSWS1	SSWS0
	Output – System No. Setting Monitor							
#3507		EXCLFN	G31IS					
		External Position Data Clear Finish	Deviation Skip Executing Output					
#3508	TLGR7	TLGR6	TLGR5	TLGR4	TLGR3	TLGR2	TLGR1	TLGR0
	Tool Life Control Group No. Output							
#3510								ISIA
	Setup Finish							
#3514		HOUT3	HOUT2	HOUT1		HIN3	HIN2	HIN1
	Output – M.M Direct Processing Signal Monitor							

Appendix Table 1.7 Operation Mode Control (cont'd)

	7	6	5	4	3	2	1	0
#3515	SETS AFL	SETS MLK		SETS DRN			SETS AES	SETS SBK
	Output – Internal Toggle Switch Monitor							
#3516						SETS EDLK		
	Output – Internal Toggle Switch Monitor							
#3517					CALEN4	CALEN3	CALEN2	CALEN1
					Calendar Output			

A1

1.2.2 NC Part Program Execution Control

Table 1.8 NC Part Program Execution Control

	7	6	5	4	3	2	1	0
#3520	MA7	MA6	MA5	MA4	MA3	MA2	MA1	MA0
	1st M Code Output							
#3521	M30 R	M02 R	M01 R	M00 R			MA9	MA8
	M Decode Output				1st M Code Output			
#3522	MB7	MB6	MB5	MB4	MB3	MB2	MB1	MB0
	2nd M Code Output							
#3523							MB9	MB8
	2nd M Code Output							
#3524	MC7	MC6	MC5	MC4	MC3	MC2	MC1	MC0
	3rd M Code Output							
#3525							MC9	MCB8
	3rd M Code Output							
#3526	MD7	MD6	MD5	MD4	MD3	MD2	MD1	MD0
	4th M Code Output							
#3527							MD9	MD8
	4th M Code Output							
#3528	ME7	ME6	ME5	ME4	ME3	ME2	ME1	ME0
	5th M Code Output							
#3529							ME9	ME8
	5th M Code Output							
#3530	T7	T6	T5	T4	T3	T2	T1	T0
	T Code Output							

Appendix Table 1.8 NC Part Program Execution Control (cont'd)

	7	6	5	4	3	2	1	0	
#3531							T9	T8	
								T Code Output	
#3535	TF			MFE	MFD	MFC	MFB	MFA	
	Output – Read M, B, T Code								
#3537	THC	RWDS	OP	DEN	RPD S	FEED S	SPL	STL	
	During Thread Cutting	During Rewinding	During Operation	Feed Completed	R State	F State	Stopped	During Operation	
	Output – Series Operation Status Monitor								
#3538					SETS OPT	SETS BDT	G93M	M04S	
					Output – Internal Toggle Switch Monitor		In Solid Tap Mode	M04 Status in Canned Cycle	
#3539					THCYS	TAP	G84S	G80S	
					During Thread Cutting Canned Cycle	Output – Canned Cycle Operation Status Monitor			
#3540	U07	U06	U05	U04	U03	U02	U01	U00	
	Macro Program Output Signal								
#3541	U015	U014	U013	U012	U011	U010	U09	U08	
	Macro Program Output Signal								
#3542	U023	U022	U021	U020	U019	U018	U017	U016	
	Macro Program Output Signal								
#3543	U031	U030	U029	U028	U027	U026	U025	U024	
	Macro Program Output Signal								

A1

1.2.3 Servo Axis Control

Appendix Table 1.9 Servo Axis Control

	7	6	5	4	3	2	1	0
#3615				FUP5	FUP4	FUPZ	FUPY	FUPX
Output – Follow-up Monitor								
#3616				PSET5	PSET4	PSETZ	PSETY	PSETX
Output – PSET Status Monitor								
#3617				DTCH 5S	DTCH 4S	DTCH 3S	DTCH 2S	DTCH 1S
Output – Axis Disconnected Status								
#3620	SRD1	* BB1		ACCO1	PSET1			
	Servo Ready	Base Block		Accel./Decel. Lag Pulse 0	Position Set			
Output – No. 1 Axis Servo Unit Monitor								
#3621	SRD2	* BB2		ACCO2	PSET2			
	Servo Ready	Base Block		Accel./Decel. Lag Pulse 0	Position Set			
Output – No. 2 Axis Servo Unit Monitor								
#3622	SRD3	* BB3		ACCO3	PSET3			
	Servo Ready	Base Block		Accel./Decel. Lag Pulse 0	Position Set			
Output – No. 3 Axis Servo Unit Monitor								
#3623	SRD4	* BB4		ACCO4	PSET4			
	Servo Ready	Base Block		Accel./Decel. Lag Pulse 0	Position Set			
Output – No. 4 Axis Servo Unit Monitor								
#3624	SRD5	* BB5		ACCO5	PSET5			
	Servo Ready	Base Block		Accel./Decel. Lag Pulse 0	Position Set			
Output – No. 5 Axis Servo Unit Monitor								

Appendix Table 1.9 Servo Axis Control (cont'd)

	7	6	5	4	3	2	1	0
#3629				ABSERR5	ABSERR4	ABSERR3	ABSERR2	ABSERR1
	Absolute Position Detection Position Error							
#3630				ZP5	ZP4	ZPZ	ZPY	ZPX
	Output - Reference Point Position Monitor							
#3631				2ZP5	2ZP4	2ZPZ	2ZPY	2ZPX
	Output - Reference Point Position Monitor							
#3632				3ZP5	3ZP4	3ZPZ	3ZPY	3ZPX
	Output - Reference Point Position Monitor							
#3633				4ZP5	4ZP4	4ZPZ	4ZPY	4ZPX
	Output - Reference Point Position Monitor							
#3640				+SOT5	+SOT4	+SOT3	+SOT2	+SOT1
	Output - Stroke Check Monitor							
#3641				-SOT5	-SOT4	-SOT3	-SOT2	-SOT1
	Output - Stroke Check Monitor							
#3642	SOT2I					SOT23	SOT22	SOT21
	Entry Prohibited Area - Inside					Check Axis 3	Check Axis 2	Check Axis 1
	Output - Stroke Check Monitor for No. 2 Entry Prohibited Area							
#3643	SOT3I					SOT33	SOT32	SOT31
	Entry Prohibited Area - Inside					Check Axis 3	Check Axis 2	Check Axis 1
	Output - Stroke Check Monitor for No. 3 Entry Prohibited Area							

A1

A1

Appendix Table 1.9 Servo Axis Control (cont'd)

	7	6	5	4	3	2	1	0
#3644	SOT4I					SOT43	SOT42	SOT41
	Entry Prohibited Area – Inside					Check Axis 3	Check Axis 2	Check Axis 1
Output – Stroke Check Monitor for No. 4 Entry Prohibited Area								
#3645	SOT5I					SOT53	SOT52	SOT51
	Entry Prohibited Area – Inside					Check Axis 3	Check Axis 2	Check Axis 1
Output – Stroke Check Monitor for No. 5 Entry Prohibited Area								
#3648				TRQLIM5	TRQLIM4	TRQLIM3	TRQLIM2	TRQLIM1
Output – Servo Axis Torque Limit Monitor								

1.2.4 No. 1 Spindle Control

Appendix Table 1.10 No. 1 Spindle Control

	7	6	5	4	3	2	1	0
#3650	GR 4S	GR 3S	GR 2S	GR 1S	GRS S	GSC S	G96 S	SINV A
	Output – Gear Range Status				Output – GRS Control Status	Output – GSC Control Status	Output – G96 Control Status	Output – S Binary Reversed Status
#3651	SF		S2COPE	S1COPE	SF	SLPS	SIDXO	SIDXA
		Output durnig Spindle Linkage		Output – S Command Sampling	Output – Spindle Position Loop Monitor	Output – Spindle Index Monitor		
#3652						SLRQ	AXMODES	CAXS
						Spindle Position Loop Request Output	NC Side Spindle Control Mode	NC Side Spindle Mode Switching
#3653						PCS	PBS	PAS
						Output – Monitor of PG Signal, etc.		
#3654	SDO7	SDO6	SDO5	SDO4	SDO3	SDO2	SDO1	SDO0
	Output – S Command Binary							
#3655	SDO15	SDO14	SDO13	SDO12	SDO11	SDO10	SDO9	SDO8
	Output – S Command Binary							
#3656	SDO23	SDO22	SDO21	SDO20	SDO19	SDO18	SDO17	SDO16
	Output – S Command Binary							

A1

1.2.5 No. 2 Spindle Control

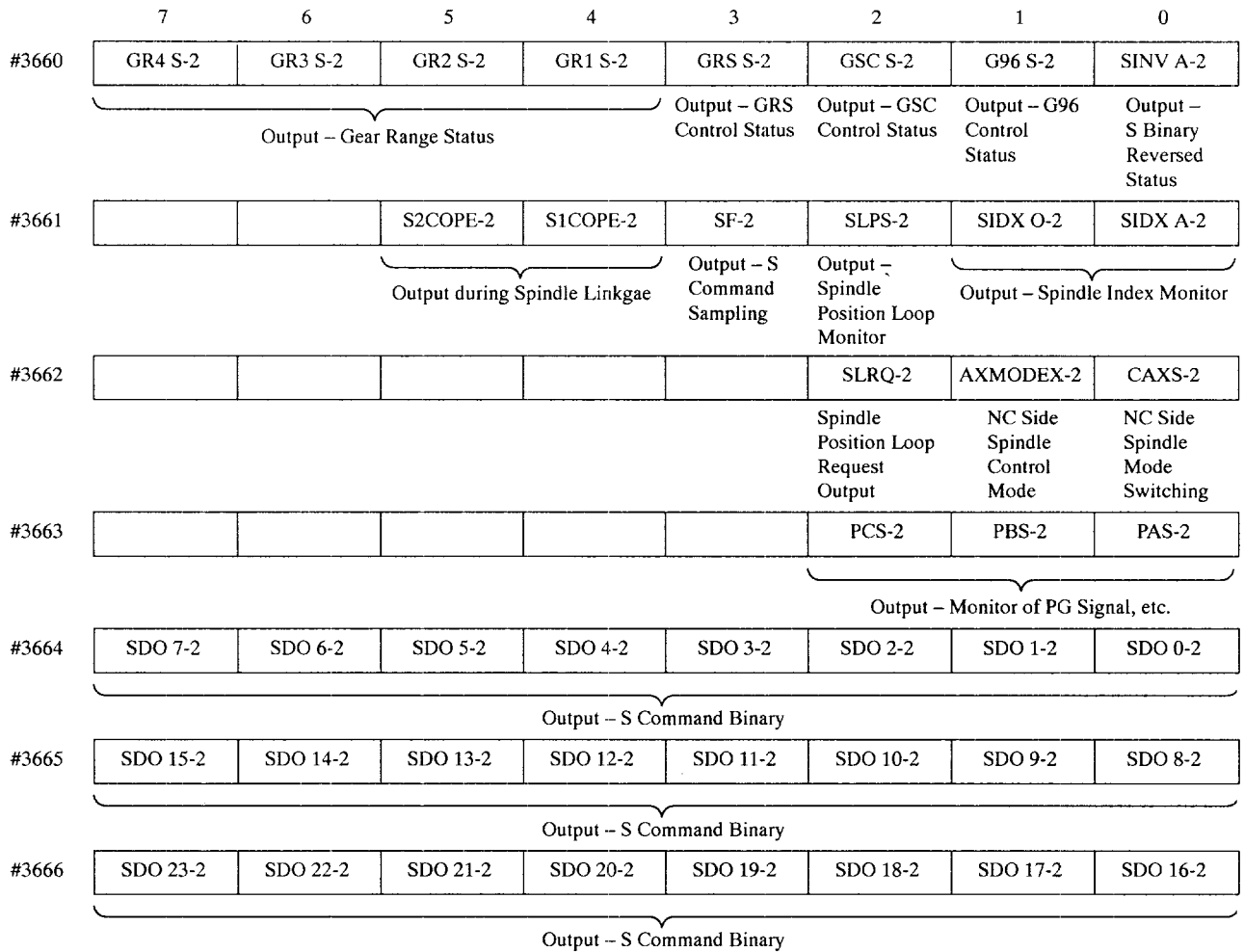

1.2.6 YENET1200 Compatible Inverter Control

Appendix Table 1.11 YENET1200 Compatible Inverter Control

	7	6	5	4	3	2	1	
#3720	SPCHWE-1	SPORE-1	SPORG-1	SPTLE-1	SPTDET-1	SPSDET-1	SPAGR-1	SPZSPD-1
	Winding Switching-Over Finish	Orientation Finish	Load Axis Zero Point	Torque Limit	Torque Detection	Speed Detection	Speed Agreed	Zero Speed
Signals for YENET1200 Compatible Inverter (No. 1 Spindle)								
#3721							SPTALM-1	SPFLT-1
							Alarm	Fault
Signals for YENET1200 Compatible Inverter (No. 1 Spindle)								
#3722	SPCHWE-2	SPORE-2	SPORG-2	SPTLE-2	SPTDET-2	SPSDET-2	SPAGR-2	SPZSPD-2
Signals for YENET1200 Compatible Inverter (No. 2 Spindle)								
#3723							SPTALM-2	SPFLT-2
Signals for YENET1200 Compatible Inverter (No. 2 Spindle)								

1.2.7 Axis Variable Data

Appendix Table 1.12 Axis Variable Data

	7	6	5	4	3	2	1	0
#3740	LD1-7	LD1-6	LD1-5	LD1-4	LD1-3	LD1-2	LD1-1	LD1-0
1st Axis Load Data (L)								
#3741	LD1-15	LD1-14	LD1-13	LD1-12	LD1-11	LD1-10	LD1-9	LD1-8
1st Axis Load Data (H)								
#3742	LD2-7	LD2-6	LD2-5	LD2-4	LD2-3	LD2-2	LD2-1	LD2-0
2nd Axis Load Data (L)								
#3743	LD2-15	LD2-14	LD2-13	LD2-12	LD2-11	LD2-10	LD2-9	LD2-8
2nd Axis Load Data (H)								
#3744	LD3-7	LD3-6	LD3-5	LD3-4	LD3-3	LD3-2	LD3-1	LD3-0
3rd Axis Load Data (L)								
#3745	LD3-15	LD3-14	LD3-13	LD3-12	LD3-11	LD3-10	LD3-9	LD3-8
3rd Axis Load Data (H)								
#3746	LD4-7	LD4-6	LD4-5	LD4-4	LD4-3	LD4-3	LD4-1	LD4-0
4th Axis Load Data (L)								
#3747	LD4-15	LD4-14	LD4-13	LD4-12	LD4-11	LD4-10	LD4-9	LD4-8
4th Axis Load Data (H)								
#3748	LD5-7	LD5-6	LD5-5	LD5-4	LD5-3	LD5-2	LD5-1	LD5-0
5th Axis Load Data (L)								
#3749	LD5-15	LD5-14	LD5-13	LD5-12	LD5-11	LD5-10	LD5-9	LD5-8
5th Axis Load Data (H)								
#3756	LDS1-7	LDS1-6	LDS1-5	LDS1-4	LDS1-3	LDS1-2	LDS1-1	LDS1-0
No. 1 Spindle Load Data (L)								
#3757	LDS1-15	LDS1-14	LDS1-13	LDS1-12	LDS1-11	LDS1-10	LDS1-9	LDS1-8
No. 1 Spindle Load Data (H)								

Appendix Table 1.12 Servo Axis Control (cont'd)

	7	6	5	4	3	2	1	0
#3758	LDS2-7	LDS2-6	LDS2-5	LDS2-4	LDS2-3	LDS2-2	LDS2-1	LDS2-0
No. 2 Spindle Load Data (L)								
#3759	LDS2-15	LDS2-14	LDS2-13	LDS2-12	LDS2-11	LDS2-10	LDS2-9	LDS2-8
No. 2 Spindle Load Data (H)								
#3764	S1RC7	S1RC6	S1RC5	S1RC4	S1RC3	S1RC2	S1RC1	S1RC0
No. 1 Spindle S RPM Command (L)								
#3765	S1RC15	S1RC14	S1RC13	S1RC12	S1RC11	S1RC10	S1RC9	S1RC8
No. 1 Spindle S RPM Command (H)								
#3764	S2RC7	S2RC6	S2RC5	S2RC4	S2RC3	S2RC2	S2RC1	S2RC0
No. 2 Spindle S RPM Command (L)								
#3765	S2RC15	S2RC14	S2RC13	S2RC12	S2RC11	S2RC10	S2RC9	S2RC8
No. 2 Spindle S RPM Command (H)								
#3772	S1RS7	S1RS6	S1RS5	S1RS4	S1RS3	S1RS2	S1RS1	S1RS0
No. 1 Spindle Actual Spindle Speed (L)								
#3773	S1RS15	S1RS14	S1RS13	S1RS12	S1RS11	S1RS10	S1RS9	S1RS8
No. 1 Spindle Actual Spindle Speed (H)								
#3774	S2RS7	S2RS6	S2RS5	S2RS4	S2RS3	S2RS2	S2RS1	S2RS0
No. 2 Spindle Actual Spindle Speed (L)								
#3775	S2RS15	S2RS14	S2RS13	S2RS12	S2RS11	S2RS10	S2RS9	S2RS8
No. 2 Spindle Actual Spindle Speed (H)								
#3780	POS1-7	POS1-6	POS1-5	POS1-4	POS1-3	POS1-2	POS1-1	POS1-0
1st Axis Position Data (L)								
#3781	POS1-15	POS1-14	POS1-13	POS1-12	POS1-11	POS1-10	POS1-9	POS1-8
1st Axis Position Data (H)								

A1

A1

Appendix Table 1.12 Servo Axis Control (cont'd)

	7	6	5	4	3	2	1	0
#3782	POS2-7	POS2-6	POS2-5	POS2-4	POS2-3	POS2-2	POS2-1	POS2-0
2nd Axis Position Data (L)								
#3783	POS2-15	POS2-14	POS2-13	POS2-12	POS2-11	POS2-10	POS2-9	POS2-8
2nd Axis Position Data (H)								
#3784	POS3-7	POS3-6	POS3-5	POS3-4	POS3-3	POS3-2	POS3-1	POS3-0
3rd Axis Position Data (L)								
#3785	POS3-15	POS3-14	POS3-13	POS3-12	POS3-11	POS3-10	POS3-9	POS3-8
3rd Axis Position Data (H)								
#3786	POS4-7	POS4-6	POS4-5	POS4-4	POS4-3	POS4-2	POS4-1	POS4-0
4th Axis Position Data (L)								
#3787	POS4-15	POS4-14	POS4-13	POS4-12	POS4-11	POS4-10	POS4-9	POS4-8
4th Axis Position Data (H)								
#3788	POS5-7	POS5-6	POS5-5	POS5-4	POS5-3	POS5-2	POS5-1	POS5-0
5th Axis Position Data (L)								
#3789	POS5-15	POS5-14	POS5-13	POS5-12	POS5-11	POS5-10	POS5-9	POS5-8
5th Axis Position Data (H)								
#3796	S1OR-7	S1OR-6	S1OR-5	S1OR-4	S1OR-3	S1OR-2	S1OR-1	S1OR-0
No. 1 Spindle Orientation Angle Data (L)								
#3797					S1OR-11	S1OR-10	S1OR-9	S1OR-8
No. 1 Spindle Orientation Angle Data (H)								
#3798	S2OR-7	S2OR-6	S2OR-5	S2OR-4	S2OR-3	S2OR-2	S2OR-1	S2OR-0
No. 2 Spindle Orientation Angle Data (L)								
#3799					S2OR-11	S2OR-10	S2OR-9	S2OR-8
No. 2 Spindle Orientation Angle Data (H)								

APPENDIX 2

PARAMETER TABLE

A2

Appendix 2 describes the classification and function of the parameters used for YASNAC J300.

2.1 CLASSIFICATION OF THE PARAMETERS	A2 - 2
2.2 PARAMETER TABLE	A2 - 3

APPENDIX 2.1 CLASSIFICATION OF THE PARAMETERS

Appendix Table 2.1 Classifications of the Parameters

No.	Classification	Data Type	Parameter No.	Sign	Power OFF/ON*	Remarks
1	Related to setting	Bit	pm0000 - pm0099			
		Byte	pm0100 - pm0109			
		Word	pm0400 - pm0429	Used		
		D-word	pm0800 - pm0939	Used		
2	Related to axis and spindle control Axis control Servo Spindle	Bit	pm1000 - pm1099		pm1020 - pm1099	
		Byte	pm1100 - pm1393		pm1300 - pm1399	
		Word	pm1400 - pm1799	Used	pm1600 - pm1799	
		D-word	pm1800 - pm1859	Used	pm1820 - pm1859	
3	Related to feed Feedrate and acceleration Thread/tap Pulse handle	Bit	pm2000 - pm2019			
		Byte	pm2100 - pm2139			
		Word	pm2400 - pm2649	Used	pm2600 - pm2649	
		D-word	pm2800 - pm2899	Used	pm2870 - pm2899	
4	Related to interface and communications Edit, tape input, display, communications, DNC	Bit	pm3000 - pm3009		pm3009	Parameters pm3008, pm3009, and pm3830 to pm3859 are validated by generation.
		Byte	pm3100 - pm3109		pm3100 - pm3109	
		Word	pm3400 - pm3459	Used	pm3400 - pm3429	
		D-word	pm3800 - pm3859	Used		
5	Related to program and automatic operation Program/automatic operation, canned cycle, offset, coordinate system, zero return, macro	Bit	pm4000 - pm4039			
		Byte	pm4100 - pm4199			
		Word	pm4400 - pm4599	Used		
		D-word	pm4800 - pm4899	Used		
6	Related to I/O and automation assisting I/O, PLC, skip, TLM	Bit	pm5000 - pm5019		pm5010 - pm5019	
		Byte	pm5100 - pm5109			
		Word	pm5400 - pm5449	Used		
		D-word	pm5800 - pm5809	Used		
7	Related to safety and maintenance (machine) Stroke check, pitch error	Bit	pm6000 - pm6009			
		Byte	pm6100 - pm6149			
		Word	pm6400 - pm6479	Used	pm6450 - pm6479	
		D-word	pm6800 - pm6949	Used		
8	PLC ladder Related to battery back-up memory	Bit	pm7000 - pm7099			Byte and word
		Byte	pm7100 - pm7999			
9	Others	Bit	pm8000 - pm8099			
		Byte	pm8100 - pm8119			
		Word	pm8400 - pm8429	Used		
		D-word	pm8800 - pm8829	Used		
10	Software switch character designation	Word	pm9000 - pm9551			

APPENDIX 2.2 PARAMETER TABLE

Appendix Table 2.2 Parameter Table

Parameter No.	Bit	Description
pm0000	0	Single-block switch 0: OFF 1: ON
	1	Machine lock switch 0: OFF 1: ON
	2	Dry run switch 0: OFF 1: ON
	3	Block delete switch 0: OFF 1: ON
	4	Manual absolute switch 0: OFF 1: ON
	5	Auxiliary function lock switch 0: OFF 1: ON
	6	Display lock switch 0: OFF 1: ON
pm0001	2	Edit lock switch 0: OFF 1: ON
	0	Optional stop switch 0: OFF 1: ON
	1	Start lock switch 0: OFF 1: ON
pm0002	7	0: In the aux. function lock state, all specified M codes are invalid. 1: In the aux. function lock state, all specified M codes are valid.
	0 - 7	Mirror image 1 to 8 0: OFF 1: ON
pm0004 Data setting for No. 1 port	0	ISO/EIA code selection for output tape code 0: ISO code 1: EIA code
	1	Execution of TV check 0: Not executed 1: Executed
	2	Counting the number of characters in () for TV check 0: Not counted 1: Counted
	3	TH check for ISO code input 0: Executed 1: Not executed
	4	Feed holes in output to tape 0: Not punched 1: Punched
	5	TH check for ISO code output 0: Executed 1: Not executed
	6	EOB codes in ISO code output 0: CR and LF 1: LF
pm0005	0	Manual zero return switch 0: OFF 1: ON
	1	No. 2 manual zero return switch 0: OFF 1: ON
	2	Interruption point return switch 0: OFF 1: ON
	3	Automatic mode handle offset switch 0: OFF 1: ON
	7	Program restart switch 0: OFF 1: ON

A2

Appendix Table 2.2 Parameter Table (cont'd)

Parameter No.	Bit	Description
pm0006 Data setting for No. 2 port	0	ISO/EIA code selection for output tape code 0: ISO code 1: EIA code
	1	Execution of TV check 0: Not executed 1: Executed
	2	Counting the number of characters in () for TV check 0: Not counted 1: Counted
	3	TH check for ISO code input 0: Executed 1: Not executed
	4	Feed holes in output to tape 0: Not punched 1: Punched
	5	TH check for ISO code output 0: Executed 1: Not executed
	6	EOB codes in ISO code output 0: CR and LF 1: LF
pm0007	0	Selection of input unit 0: mm 1: inches
	1	Operation instructions and control instructions in user macro 0: Not interrupted by single-block stop. 1: Interrupted by single-block stop.
	2	Occurrence of an alarm if skip signal is not turned ON until the completion of axis move specified in the skip function block 0: An alarm occurs. 1: An alarm does not occur.
	4	Tool life control tool search and life count 0: Executed 1: Not executed
	5	Display of program list during input/output/verify of a program 0: Program list is displayed. 1: Program list not displayed.
	6	"0" data in parameter output 0: "0" data are output. 1: "0" data are not output.
	7	Buzzer sound for the operation of keys in the keyboard 0: No buzzer sound 1: Buzzer sound

Appendix Table 2.2 Parameter Table (cont'd)

Parameter No.	Bit	Description																														
pm0008	0 - 3	No. 2 to 5 stored stroke limit 0: Invalid 1: Valid																														
	4 - 7	No. 2 to 5 entry prohibited area 0: Inside the boundary 1: Outside the boundary																														
pm0009	0	Selection of input port 0: No. 1 port 1: No. 2 port																														
	1	Tool life count (use count) is made by 0: M code specified for pm4531 1: T9999																														
	4	Selection of output port 0: No. 1 port 1: No. 2 port																														
	5	Alarm occurrence if the condition is not satisfied until the completion of axis movement in the block of deviation skip function 0: Alarm occurs. 1: Alarm does not occur.																														
	6.7	Number of tool life control groups and tools (pm0009) <table border="1"> <thead> <tr> <th>Groups</th> <th>Tools</th> <th>D7</th> <th>D6</th> </tr> </thead> <tbody> <tr> <td>① 64</td> <td>4</td> <td>0</td> <td>0</td> </tr> <tr> <td>② 32</td> <td>8</td> <td>0</td> <td>1</td> </tr> <tr> <td>③ 16</td> <td>16</td> <td>1</td> <td>0</td> </tr> <tr> <td>④ 8</td> <td>32</td> <td>1</td> <td>1</td> </tr> </tbody> </table>	Groups	Tools	D7	D6	① 64	4	0	0	② 32	8	0	1	③ 16	16	1	0	④ 8	32	1	1										
Groups	Tools	D7	D6																													
① 64	4	0	0																													
② 32	8	0	1																													
③ 16	16	1	0																													
④ 8	32	1	1																													
pm0010 No. 1 port device designation	0 - 3	Input device setting <table border="1"> <thead> <tr> <th>D3</th> <th>D2</th> <th>D1</th> <th>D0</th> <th></th> </tr> </thead> <tbody> <tr> <td>0</td> <td>0</td> <td>0</td> <td>0</td> <td>Reserved</td> </tr> <tr> <td>0</td> <td>0</td> <td>0</td> <td>1</td> <td>YE tape reader</td> </tr> <tr> <td>0</td> <td>0</td> <td>1</td> <td>0</td> <td>General-purpose RS-232C device</td> </tr> <tr> <td>0</td> <td>0</td> <td>1</td> <td>1</td> <td>Not used</td> </tr> <tr> <td>1</td> <td>1</td> <td>1</td> <td>1</td> <td></td> </tr> </tbody> </table>	D3	D2	D1	D0		0	0	0	0	Reserved	0	0	0	1	YE tape reader	0	0	1	0	General-purpose RS-232C device	0	0	1	1	Not used	1	1	1	1	
	D3	D2	D1	D0																												
0	0	0	0	Reserved																												
0	0	0	1	YE tape reader																												
0	0	1	0	General-purpose RS-232C device																												
0	0	1	1	Not used																												
1	1	1	1																													
4 - 7	Output device setting <table border="1"> <thead> <tr> <th>D7</th> <th>D6</th> <th>D5</th> <th>D4</th> <th></th> </tr> </thead> <tbody> <tr> <td>0</td> <td>0</td> <td>0</td> <td>0</td> <td>Reserved 1</td> </tr> <tr> <td>0</td> <td>0</td> <td>0</td> <td>1</td> <td>Reserved 2</td> </tr> <tr> <td>0</td> <td>0</td> <td>1</td> <td>0</td> <td>General-purpose RS-232C device</td> </tr> <tr> <td>0</td> <td>0</td> <td>1</td> <td>1</td> <td>Not used</td> </tr> <tr> <td>1</td> <td>1</td> <td>1</td> <td>1</td> <td></td> </tr> </tbody> </table>	D7	D6	D5	D4		0	0	0	0	Reserved 1	0	0	0	1	Reserved 2	0	0	1	0	General-purpose RS-232C device	0	0	1	1	Not used	1	1	1	1		
D7	D6	D5	D4																													
0	0	0	0	Reserved 1																												
0	0	0	1	Reserved 2																												
0	0	1	0	General-purpose RS-232C device																												
0	0	1	1	Not used																												
1	1	1	1																													

A2

A2

Appendix Table 2.2 Parameter Table (cont'd)

Parameter No.	Bit	Description
pm0011 Communication parameter setting No. 1 port (input) for general-purpose RS-232C device (format)	0 - 2	BPS setting
		D2 D1 D0
		0 0 0 100 or 75
		0 0 1 110 or 150
		0 1 0 300
		0 1 1 600
1 0 0 1200		
1 0 1 2400		
1 1 0 4800		
1 1 1 9600		
pm0012 Communication parameter setting No. 1 port (input) for general-purpose RS-232C device (control)	3	Stop bit length 0: 1 bit 1: 2 bits
	4	Data length 0: 7 bits 1: 8 bits
	5.6	Parity bit D6 D5 0 0 No parity 0 1 Even parity 1 0 Odd parity
	7	Setting of low baud rate selection 0: 100 and 110 bps 1: 75 and 150 bps
	0	Control by control code 0: Not executed 1: Executed
1	RTS control 0: Not executed 1: Executed	
2	DR line check 0: Not executed 1: Executed	
7	NC data special control 0: Not executed 1: Executed	

Appendix Table 2.2 Parameter Table (cont'd)

Parameter No.	Bit	Description
pm0013	0 - 2	BPS setting
		D2 D1 D0
		0 0 0 100 or 75
		0 0 1 110 or 150
		0 1 0 300
0 1 1 600		
1 0 0 1200		
1 0 1 2400		
1 1 0 4800		
1 1 1 9600		
Communication parameter setting No. 1 port (output) for general-purpose RS-232C device (format)	3	Stop bit length 0: 1 bit 1: 2 bits
	4	Data length 0: 7 bits 1: 8 bits
	5,6	Parity bit D6 D5 0 0 No parity 0 1 Even parity 1 0 Odd parity
	7	Setting of low baud rate selection 0: 100 and 110 bps 1: 75 and 150 bps
	pm0014	0
1		RTS control 0: Not executed 1: Executed
2		DR line check 0: Not executed 1: Executed
7		NC data special control 0: Not executed 1: Executed

A2

A2

Appendix Table 2.2 Parameter Table (cont'd)

Parameter No.	Bit	Description
pm0015 No. 2 port device designation	0 - 3	Input device setting
		D3 D2 D1 D0
0 0 0 0 Reserved		
0 0 0 1 YE tape reader		
0 0 1 0 General-purpose RS-232C device		
0 0 1 1 Not used		
4 - 7	Output device setting	
	D7 D6 D5 D4	
	0 0 0 0 Reserved 1	
	0 0 0 1 Reserved 2	
	0 0 1 0 General-purpose RS-232C device	
0 0 1 1 Not used		
pm0016 Communication parameter setting No. 2 port (output) for general-purpose RS-232C device (format)	0 - 2	BPS setting
		D2 D1 D0
		0 0 0 100 or 75
		0 0 1 110 or 150
		0 1 0 300
0 1 1 600		
1 0 0 1200		
1 0 1 2400		
1 1 0 4800		
1 1 1 9600		
3	Stop bit length 0: 1 bit 1: 2 bits	
4	Data length 0: 7 bits 1: 8 bits	
5.6	Parity bit	
	D6 D5	
	0 0 No parity	
0 1 Even parity		
1 0 Odd parity		
7	Setting of low baud rate selection 0: 100 and 110 bps 1: 75 and 150 bps	

Appendix Table 2.2 Parameter Table (cont'd)

Parameter No.	Bit	Description																																				
pm0017 Communication parameter setting No. 2 port (output) for general-purpose RS-232C device (control)	0	Control by control code 0: Not executed 1: Executed																																				
	1	RTS control 0: Not executed 1: Executed																																				
	2	DR line check 0: Not executed 1: Executed																																				
	7	NC data special control 0: Not executed 1: Executed																																				
pm0018 Communication parameter setting No. 2 port (output) for general-purpose RS-232C device (format)	0 - 2	BPS setting <table border="1"> <thead> <tr> <th>D2</th> <th>D1</th> <th>D0</th> <th></th> </tr> </thead> <tbody> <tr> <td>0</td> <td>0</td> <td>0</td> <td>100 or 75</td> </tr> <tr> <td>0</td> <td>0</td> <td>1</td> <td>110 or 150</td> </tr> <tr> <td>0</td> <td>1</td> <td>0</td> <td>300</td> </tr> <tr> <td>0</td> <td>1</td> <td>1</td> <td>600</td> </tr> <tr> <td>1</td> <td>0</td> <td>0</td> <td>1200</td> </tr> <tr> <td>1</td> <td>0</td> <td>1</td> <td>2400</td> </tr> <tr> <td>1</td> <td>1</td> <td>0</td> <td>4800</td> </tr> <tr> <td>1</td> <td>1</td> <td>1</td> <td>9600</td> </tr> </tbody> </table>	D2	D1	D0		0	0	0	100 or 75	0	0	1	110 or 150	0	1	0	300	0	1	1	600	1	0	0	1200	1	0	1	2400	1	1	0	4800	1	1	1	9600
	D2	D1	D0																																			
	0	0	0	100 or 75																																		
	0	0	1	110 or 150																																		
	0	1	0	300																																		
0	1	1	600																																			
1	0	0	1200																																			
1	0	1	2400																																			
1	1	0	4800																																			
1	1	1	9600																																			
3	Stop bit length 0: 1 bit 1: 2 bits																																					
4	Data length 0: 7 bits 1: 8 bits																																					
5.6	Parity bit <table border="1"> <thead> <tr> <th>D6</th> <th>D5</th> <th></th> </tr> </thead> <tbody> <tr> <td>0</td> <td>0</td> <td>No parity</td> </tr> <tr> <td>0</td> <td>1</td> <td>Even parity</td> </tr> <tr> <td>1</td> <td>0</td> <td>Odd parity</td> </tr> </tbody> </table>	D6	D5		0	0	No parity	0	1	Even parity	1	0	Odd parity																									
D6	D5																																					
0	0	No parity																																				
0	1	Even parity																																				
1	0	Odd parity																																				
7	Setting of low baud rate selection 0: 100 and 110 bps 1: 75 and 150 bps																																					

A2

Appendix Table 2.2 Parameter Table (cont'd)

Parameter No.	Bit	Description																																																
pm0019 Communication parameter setting No. 2 port (output) for general-purpose RS-232C device (control)	0	Control by control code 0: Not executed 1: Executed																																																
	1	RTS control 0: Not executed 1: Executed																																																
	2	DR line check 0: Not executed 1: Executed																																																
	7	NC data special control 0: Not executed 1: Executed																																																
pm0020	0	Edit, display, and input/output operation of part programs O8000 to O8999 0: Permitted 1: Prohibited																																																
pm0021	0	Edit and I/O operation of O8000 to O8999 0: Permitted 1: Prohibited																																																
pm0022	0	Edit and I/O operation of O9000 to O9999 0: Permitted 1: Prohibited																																																
pm0023	0 - 4	Override of G71, G72 in-feed (1 = 10%) <table border="1" style="margin-left: 20px;"> <thead> <tr> <th>D4</th> <th>D3</th> <th>D2</th> <th>D1</th> <th>D0</th> <th>%</th> </tr> </thead> <tbody> <tr> <td>0</td> <td>0</td> <td>0</td> <td>0</td> <td>0</td> <td>100</td> </tr> <tr> <td>0</td> <td>0</td> <td>0</td> <td>0</td> <td>1</td> <td>10</td> </tr> <tr> <td>0</td> <td>0</td> <td>0</td> <td>1</td> <td>0</td> <td>20</td> </tr> <tr> <td>0</td> <td>0</td> <td>0</td> <td>1</td> <td>1</td> <td>30</td> </tr> <tr> <td>0</td> <td>1</td> <td>0</td> <td>1</td> <td>0</td> <td>100</td> </tr> <tr> <td>1</td> <td>0</td> <td>1</td> <td>0</td> <td>0</td> <td>200</td> </tr> <tr> <td>1</td> <td>0</td> <td>1</td> <td>0</td> <td>1</td> <td>200</td> </tr> </tbody> </table>	D4	D3	D2	D1	D0	%	0	0	0	0	0	100	0	0	0	0	1	10	0	0	0	1	0	20	0	0	0	1	1	30	0	1	0	1	0	100	1	0	1	0	0	200	1	0	1	0	1	200
		D4	D3	D2	D1	D0	%																																											
0	0	0	0	0	100																																													
0	0	0	0	1	10																																													
0	0	0	1	0	20																																													
0	0	0	1	1	30																																													
0	1	0	1	0	100																																													
1	0	1	0	0	200																																													
1	0	1	0	1	200																																													
6	Writing the data on the cutting monitor data list screen 0: Possible 1: Impossible																																																	
pm0030	0	Communication module device designation 0: RS-232C 1: RS-422																																																
	1	NC unit tape mode operation device designation 0: PTR 1: Communication module																																																

Appendix Table 2.2 Parameter Table (cont'd)

Parameter No.	Bit	Description
pm0031 Communication parameter setting RS-232C	0 - 2	BPS setting
		D2 D1 D0
		0 0 0 1200
		0 0 1 2400
0 1 0 4800		
0 1 1 9600		
1 0 0 19200		
3	Stop bit length 0: 1 bit 1: 2 bits	
4	Data length 0: 7 bits 1: 8 bits	
5.6	Parity bit	
	D6 D5	
	0 0 No parity	
	0 1 Even parity	
	1 0 Odd parity	
pm0032 Communication parameter setting RS-422	0 - 2	BPS setting
		D2 D1 D0
		0 0 0 1200
		0 0 1 2400
0 1 0 4800		
0 1 1 9600		
1 0 0 19200		
3	Stop bit length 0: 1 bit 1: 2 bits	
4	Data length 0: 7 bits 1: 8 bits	
5.6	Parity bit	
	D6 D5	
	0 0 No parity	
	0 1 Even parity	
	1 0 Odd parity	

A2

A2

Appendix Table 2.2 Parameter Table (cont'd)

Parameter No.	Bit	Description																																				
pm1000	0	Designation of inputs 0: Least input unit 1: 10 times the least input unit																																				
	1	X-axis value designation 0: Diameter 1: Radius																																				
	5	SSTP setting for "0" output in response to "0" S command 0: SSTP "0" 1: SSTP "1"																																				
	6	C-axis related servo alarm while C-axis is disconnected 0: Alarm 1: Disregarded																																				
	7	Checking of SAGR when feedrate is changed from rapid traverse to cutting feedrate. 0: Not checked 1: Checked																																				
pm1001	1	Y-axis value designation 0: Diameter 1: Radius																																				
pm1002	0 - 3	Magnification ratio of 1st to 4th axis speed parameter 0: $\times 1$ 1: $\times 10$																																				
pm1003	0	Monitoring of spindle PG in back-machining spindle synchronization control (1) 0: Not executed 1: Executed																																				
	1	Monitoring of spindle PG in back-machining spindle synchronization control (2) 0: Not executed 1: Executed																																				
	2 - 5	Loop back of D/A sequence of No. 1 to No. 4 spindles 0: Provided 1: Not provided																																				
pm1004 - pm1008	2 - 4	1st - 5th axis logical axis No. <table style="margin-left: 20px;"> <thead> <tr> <th>D4</th> <th>D3</th> <th>D2</th> <th></th> </tr> </thead> <tbody> <tr> <td>0</td> <td>0</td> <td>0</td> <td>1st logical axis</td> </tr> <tr> <td>0</td> <td>0</td> <td>1</td> <td>1st logical axis</td> </tr> <tr> <td>0</td> <td>1</td> <td>0</td> <td>2nd logical axis</td> </tr> <tr> <td>0</td> <td>1</td> <td>1</td> <td>3rd logical axis</td> </tr> <tr> <td>1</td> <td>0</td> <td>0</td> <td>4th logical axis</td> </tr> <tr> <td>1</td> <td>0</td> <td>1</td> <td>5th logical axis</td> </tr> <tr> <td>1</td> <td>1</td> <td>0</td> <td>6th logical axis</td> </tr> <tr> <td>1</td> <td>1</td> <td>1</td> <td>1st logical axis</td> </tr> </tbody> </table>	D4	D3	D2		0	0	0	1st logical axis	0	0	1	1st logical axis	0	1	0	2nd logical axis	0	1	1	3rd logical axis	1	0	0	4th logical axis	1	0	1	5th logical axis	1	1	0	6th logical axis	1	1	1	1st logical axis
D4	D3	D2																																				
0	0	0	1st logical axis																																			
0	0	1	1st logical axis																																			
0	1	0	2nd logical axis																																			
0	1	1	3rd logical axis																																			
1	0	0	4th logical axis																																			
1	0	1	5th logical axis																																			
1	1	0	6th logical axis																																			
1	1	1	1st logical axis																																			

Appendix Table 2.2 Parameter Table (cont'd)

Parameter No.	Bit	Description
pm1014 - pm1017	2 - 4	No. 1 - No. 5 spindle logical axis No. D4 D3 D2
		0 0 0 No. 1 logical spindle
		0 0 1 No. 1 logical spindle
		0 1 0 No. 2 logical spindle
		0 1 1 No. 3 logical spindle
		1 0 0 No. 4 logical spindle
		1 0 1 No. 1 logical spindle
		1 1 0 No. 1 logical spindle
pm1018 - pm1022	2 - 4	1st - 5th physical servo axis YENET1200 station No. setting (No. 2 - No. 15 stations)
		D3 D2 D1 D0 Alarm D3 D2 D1 D0
		0 0 0 0 Alarm 0 0 0 1 No. 8 station
		1 0 0 0 Alarm 1 0 0 1 No. 9 station
		0 1 0 0 No. 2 station 0 1 0 1 No. 10 station
		1 1 0 0 No. 3 station 1 1 0 1 No. 11 station
		0 0 1 0 No. 4 station 0 0 1 1 No. 12 station
		1 0 1 0 No. 5 station 1 0 1 1 No. 13 station
	0 1 1 0 No. 6 station 0 1 1 1 No. 14 station	
	1 1 1 0 No. 7 station 1 1 1 1 No. 15 station	
6	1st - 5th physical servo axis specification 0: Servo axis 1: C-axis integral with spindle	
	7	1st - 5th physical servo axis 0: Invalid 1: Valid
pm1026 - pm1029	0 - 3	1st - 4th physical spindle YENET1200 station No. setting (No. 2 - No. 15 stations)
		D3 D2 D1 D0 Alarm D3 D2 D1 D0
		0 0 0 0 Alarm 0 0 0 1 No. 8 station
		1 0 0 0 Alarm 1 0 0 1 No. 9 station
		0 1 0 0 No. 2 station 0 1 0 1 No. 10 station
		1 1 0 0 No. 3 station 1 1 0 1 No. 11 station
		0 0 1 0 No. 4 station 0 0 1 1 No. 12 station
		1 0 1 0 No. 5 station 1 0 1 1 No. 13 station
	0 1 1 0 No. 6 station 0 1 1 1 No. 14 station	
	1 1 1 0 No. 7 station 1 1 1 1 No. 15 station	
6	No. 1 - No. 4 physical spindle 0: Normal spindle 1: C-axis integral with spindle	
	7	No. 1 - No. 4 physical spindle 0: Invalid 1: Valid

A2

A2

Appendix Table 2.2 Parameter Table (cont'd)

Parameter No.	Bit	Description												
pm1030 - pm1034 1st - 5th axis servo control type	0	Velocity loop control method 0: PI 1: IP												
	1	Velocity loop control automatic setting 0: Invalid 1: Valid												
	2	Full-closed control method 0: Invalid 1: Valid												
	3	Axis designation 0: Normal axis designation (1 = 1 μm) 1: Linear axis designation (1 = 0.5 μm)												
	4	Reverse connection of separately installed PG 0: Invalid 1: Valid												
	5	0: Servo axis 1: C-axis integral with spindle												
	6	Axis type 0: Linear axis 1: Rotary axis												
	7	Motor rotation direction 0: Forward rotation 1: Reverse rotation												
pm1039 - pm1042 No. 1 - No. 4 spindle servo control type	1.2	<table border="0"> <tr> <td>D2</td> <td>D1</td> <td>Use of PG</td> </tr> <tr> <td>0</td> <td>0</td> <td>No PG for spindle</td> </tr> <tr> <td>0</td> <td>1</td> <td>PG used at the spindle</td> </tr> <tr> <td>1</td> <td>0</td> <td>PG used at the motor</td> </tr> </table>	D2	D1	Use of PG	0	0	No PG for spindle	0	1	PG used at the spindle	1	0	PG used at the motor
	D2	D1	Use of PG											
	0	0	No PG for spindle											
0	1	PG used at the spindle												
1	0	PG used at the motor												
5	No. 1 spindle servo control 0: Executed 1: Not executed													
7	No. 1 spindle configuration 0: Normal spindle 1: C-axis integral with spindle													

Appendix Table 2.2 Parameter Table (cont'd)

Parameter No.	Bit	Description
pm1044 - pm1048 1st-axis - 5th-axis	0	Servo feed amount change 0: Not executed 1: Executed
	1	Absolute encoder 0: Motor PG 1: Separately installed PG
	2	Disregarding error pulses at the input of emergency stop 0: Not disregarded 1: Disregarded
	3	Execution of follow-up processing for the input of servo OFF 0: Not executed 1: Executed
	4	Use of absolute encoder 0: Not used 1: Used
	5	Parameter for setting virtual C-phase interval in zero return 0: 1 turn of motor (pm1821) 1: 1 turn of motor (pm1851)
pm1053 - pm1056 No. 1 - No. 4 spindle	2	Execution of spindle indexing in loop control 0: Not executed 1: Executed
	3	Execution of C-axis indexing when switching to C-axis 0: Not executed 1: Executed
	4	Special spindle indexing 0: Invalid 1: Valid
pm1058	0 - 3	Speed agreement signal of No. 1 to No. 4 spindle 0: Not checked 1: Checked

A2

A2

Appendix Table 2.2 Parameter Table (cont'd)

Parameter No.	Bit	Description
pm1061 - pm1065	0 - 7	Setting of motor selection code for “n”th-axis
		Setting Motor Type Setting Motor Type
		51 USAGED-03A/C 91 USAGED-03B/D
		52 -05A/C 92 -05B/D
		53 -09A/C 93 -09B/D
		54 -13A/C 94 -13B/D
		55 -20A/C 95 -20B/D
		56 -30A/C 96 -30B/D
		57 -44A/C 97 -44B/D
		Setting Motor Type Setting Motor Type
		142 SGMG-05A□A 171 SGMG-03A□B
		143 -09A□A 172 -06A□B
		144 -13A□A 173 -09A□B
		145 -20A□A 174 -12A□B
146 -30A□A 175 -20A□B		
147 -44A□A 176 -30A□B		
175 -44A□B		
pm1070	0 - 4	Availability of disturbance observer function for 1st - 5th axis 0: Not available 1: Available
pm1071 - pm1075		Setting of servo axis encoder type for 1st - 5th axis
		Type Setting
		Linear scale 0
		15-bit ABS 1
		15-bit ABS (rotary axis) 2
		17-bit ABS 3
		8192-pulse new INC 11
		25000-pulse new INC 18
30000-pulse new INC 19		
360000-pulse new INC 23		
1024-pulse spindle INC 21		
pm1081 - pm1085		Setting of separately installed servo encoder type for 1st - 5th axis
		Type Setting
		Linear scale 0
		15-bit ABS 1
		15-bit ABS (rotary axis) 2
		17-bit ABS 3
		8192-pulse new INC 11
		25000-pulse new INC 18
30000-pulse new INC 19		
360000-pulse C-axis INC 23		

Appendix Table 2.2 Parameter Table (cont'd)

Parameter No.	Bit	Description																
pm1091 - pm1094		Setting of encoder type for No. 1 - No. 4 spindle <table style="width: 100%; border: none;"> <tr> <td style="width: 50%;">Type</td> <td style="width: 50%;">Setting</td> </tr> <tr> <td>Linear scale</td> <td>0</td> </tr> <tr> <td>15-bit ABS</td> <td>1</td> </tr> <tr> <td>15-bit ABS (rotary axis)</td> <td>2</td> </tr> <tr> <td>17-bit ABS</td> <td>3</td> </tr> <tr> <td>8192-pulse new INC</td> <td>11</td> </tr> <tr> <td>360000-pulse C-axis INC</td> <td>23</td> </tr> <tr> <td>1024-pulse spindle INC</td> <td>21</td> </tr> </table>	Type	Setting	Linear scale	0	15-bit ABS	1	15-bit ABS (rotary axis)	2	17-bit ABS	3	8192-pulse new INC	11	360000-pulse C-axis INC	23	1024-pulse spindle INC	21
	Type	Setting																
	Linear scale	0																
	15-bit ABS	1																
	15-bit ABS (rotary axis)	2																
	17-bit ABS	3																
	8192-pulse new INC	11																
360000-pulse C-axis INC	23																	
1024-pulse spindle INC	21																	
pm1096	0	Command unit designation 0: Microns 1: Sub-microns																
pm1098	0 - 4	Torque limiter function for 1st - 5th axis 0: Invalid 1: Valid																
pm2000	0	Dry run during rapid traverse 0: Invalid 1: Valid																
	1	Dry run during thread cutting 0: Valid 1: Invalid																
	2	Spindle override during tapping 0: Not clamped at 100% 1: Clamped at 100% (only for lathe)																
	3	Setting of input unit for pm2447 (F ₀ feedrate) 0: mm/min 1: %																
	4	Validity of feedrate override signal 0: Valid when "1" (NO contact) 1: Valid when "0" (NC contact)																
	6	Replacing rapid traverse with jog until the completion of reference point return after turning ON the power 0: Rapid traverse is not replaced with jog. 1: Rapid traverse is replaced with jog.																
	7	Setting jog feedrate of rotary axis at 1/10 of that of linear axis 0: Not set at 1/10 1: Set at 1/10																
pm2001	0	Feedrate for skip function 0: As specified by F code 1: As set by parameter																
	3	Feedrate applied for the execution of deviation skip function 0: F code 1: Parameter setting																

A2

Appendix Table 2.2 Parameter Table (cont'd)

Parameter No.	Bit	Description
pm2002	0 - 4	Validity of automatic mode handle offset (1st - 5th axis) 0: Invalid 1: Valid
pm2003	1	Valid operation of automatic mode handle offset 0: Other than rapid traverse 1: Only in the interpolation mode
pm2004	0	Feedrate at the detection unit of 0.001 mm or 0.0001 inch 0: F6.0 mm/min or F5.2 inch/min 1: F6.3 mm/min or F5.4 inch/min
	1	Feedrate at the detection unit of 0.001 mm or 0.0001 inch 0: F33 mm/rev or F24 inch/rev 1: F42 mm/rev or F24 inch/rev
pm3000	0	Presetting of the external position data display at the setting of a coordinate system 0: Not preset 1: Preset
	1	Resetting of the external position data display to "0" at the completion of low-speed manual reference point return 0: Not cleared to "0" 1: Cleared to "0"
	2	Addition of tool position offset amount in Z-axis position data for display 0: Added 1: Not added
	3	Position data display change (workpiece shift coordinate system screen, correction amount screen) 0: Machine coordinate system 1: Workpiece coordinate system
	6	Offset data by X, Y, and Z 0: Possible 1: Impossible
pm3001	0	External timer display 0: Invalid 1: Valid

Appendix Table 2.2 Parameter Table (cont'd)

Parameter No.	Bit	Description
pm3002	0	Clear of MDI buffer if EOP is ON with program reset (M30/M02) specified. 0: Cleared 1: Not cleared
	1	Clear of MDI buffer by panel reset or external reset 0: Cleared 1: Not cleared
	2	Start position of MDI program 0: Present cursor position 1: Beginning of the MDI program
	6	EDIT process address search 0: Character search 1: Binary search
	7	RUN process address search 0: Binary search 1: Character search
pm3003	0.1	Initial screen at power ON D1 D0 0 0 4POS 0 1 Program check screen 1 0 Edit screen 1 1 4POS
	4	Clearing of the program that requires the check for alarm 0: Cleared by reset operation 1: Cleared by reset operation after the check for the alarm
pm3004	0	Edit/display/output of part programs of O9000 to O9999 0: Permitted 1: Prohibited

A2

A2

Appendix Table 2.2 Parameter Table (cont'd)

Parameter No.	Bit	Description																			
pm3005	0	Processing if the same O number already exists in loading a program from tape 0: Warning 1: Existing program is overwritten by new program																			
	1	Clearing of the program numbers at power ON 0: Cleared 1: Not cleared																			
	2	Definition of program number 0: Numerical value specified following O 1: Numerical value specified following O or N																			
	3	Interpretation of M code (M02, M30, M*99 [*: 0 - 3]) read at the end of program loading from tape 0: Regarded as program end 1: Not regarded as program end																			
	4	Automatic editing of a program number in program rename/copy/storing operation 0: Edited automatically 1: Not edited																			
	5	Conversion of “:” code (ISO) at input and output 0: Not converted 1: Converted																			
	6	Conversion of “:” code (ISO) at input and output (valid if pm3005 D5 = 1) 0: Not converted 1: Converted																			
pm3006	0	Identification of tape operation device 0: I/O input specification 1: Setting specification																			
	1	Designation of processing at the occurrence of communication module error 0: NC placed in the alarm state 1: NC not placed in the alarm state																			
	2.3	Buffer area data storing amount at the start of DNC operation <table border="1" style="margin-left: 20px;"> <thead> <tr> <th>D3</th> <th>D2</th> <th>Bytes</th> </tr> </thead> <tbody> <tr> <td>0</td> <td>0</td> <td>2048</td> </tr> <tr> <td>0</td> <td>1</td> <td>128</td> </tr> <tr> <td>1</td> <td>0</td> <td>256</td> </tr> <tr> <td>1</td> <td>1</td> <td>512</td> </tr> </tbody> </table>	D3	D2	Bytes	0	0	2048	0	1	128	1	0	256	1	1	512				
	D3	D2	Bytes																		
	0	0	2048																		
0	1	128																			
1	0	256																			
1	1	512																			
4	Designation of the transmission of the control character 0: Not transmitted 1: Transmitted																				
5 - 7	Communication module protocol <table border="1" style="margin-left: 20px;"> <thead> <tr> <th>D7</th> <th>D6</th> <th>D5</th> <th></th> </tr> </thead> <tbody> <tr> <td>0</td> <td>0</td> <td>0</td> <td>Protocol 1</td> </tr> <tr> <td>0</td> <td>0</td> <td>1</td> <td>Protocol 2</td> </tr> <tr> <td>0</td> <td>1</td> <td>0</td> <td>Protocol 3</td> </tr> <tr> <td>0</td> <td>1</td> <td>1</td> <td>Protocol 4</td> </tr> </tbody> </table>	D7	D6	D5		0	0	0	Protocol 1	0	0	1	Protocol 2	0	1	0	Protocol 3	0	1	1	Protocol 4
D7	D6	D5																			
0	0	0	Protocol 1																		
0	0	1	Protocol 2																		
0	1	0	Protocol 3																		
0	1	1	Protocol 4																		

Appendix Table 2.2 Parameter Table (cont'd)

Parameter No.	Bit	Description												
pm3007	0	“0” setting of external position data display at the completion of manual reference point return 0: Only in low-speed type manual reference point return 1: Both for low-speed and high-speed manual reference point return (Valid when pm3000 D1 = 1)												
	2	Program input in the edit lock status 0: Impossible 1: Possible												
	3	Program output and verify in the edit lock status 0: Impossible 1: Possible												
	7	Buffering of 150-byte DAT binary data after the reception of the WAT command by the communication module. 0: Buffered 1: Not buffered												
pm4000	0	Selection of G code in 01-group when the power is turned ON or the NC is reset 0: G00 1: G01												
	1	Selection of G code in 03-group when the power is turned ON 0: G90 1: G91												
	2	Selection of G code in 04-group when the power is turned ON 0: G98 1: G99												
	3.4	Selection of G code in 08-group when the power is turned ON <table border="1" style="display: inline-table; vertical-align: middle;"> <tr> <td>D4</td> <td>D3</td> <td></td> </tr> <tr> <td>0</td> <td>0</td> <td>G49</td> </tr> <tr> <td>0</td> <td>1</td> <td>G43</td> </tr> <tr> <td>1</td> <td>0</td> <td>G44</td> </tr> </table>	D4	D3		0	0	G49	0	1	G43	1	0	G44
	D4	D3												
0	0	G49												
0	1	G43												
1	0	G44												
7	G codes to be used 0: Standard G codes 1: Special G codes													
pm4001	1	Initial M code mode when the power is turned ON or the NC is reset 0: M96 (arc) 1: M97 (linear)												
	5	G code in 12 group to be set at power ON or reset 0: G52 1: G53												
	7	Cycle interlock at system No. switch “1” or pm0109 D0 = 1 0: Not available 1: Available												

A2

Appendix Table 2.2 Parameter Table (cont'd)

Parameter No.	Bit	Description
pm4002	0 - 4	Reference point return direction (1st - 5th axis) 0: Positive direction 1: Negative direction
pm4003	4	Automatic coordinate system setting at the completion of manual zero return 0: All axes 1: Only rotary axis
	5	Automatic setting of tool coordinate memory No. by external input 0: Not executed 1: Executed
	6	Manual reference point return type in the second and later operation after power ON 0: High-speed type 1: Low-speed type
	7	Automatic reference point return type in the second and later operation after power ON 0: High-speed type 1: Low-speed type
pm4004	0 - 4	Occurrence of alarm if movement command other than G28 is executed without carrying out manual or automatic reference point return after power ON (1st - 5th axis) 0: Alarm does not occur. 1: Alarm occurs.
pm4006	0 - 4	Automatic coordinate system setting (1st - 5th axis) 0: Invalid 1: Valid
pm4008	0	Returning of the execution pointer to the start of the program when the NC is reset by the external key operation 0: Returned 1: Not returned
	1	Rewinding of tape by M30 when YASNAC standard tape reader is connected to the No. 1 RS-232C port 0: Not rewind 1: Rewound
	2	Rewinding of tape by M30 when YASNAC standard tape reader is connected to the No. 2 RS-232C port 0: Not rewind 1: Rewound
	3	Possibility of starting of memory operation from a mid point of a block 0: Possible 1: Not possible; always started from the beginning of a block
	7	High-speed automatic start for high-speed rewind operation 0: Does not start at high-speed 1: Start at high-speed

Appendix Table 2.2 Parameter Table (cont'd)

Parameter No.	Bit	Description
pm4009	0	Present value is input to system variables #5001 and on at the execution of G31 skip. 0: Present value 1: Command value
	1	Macroprogram common variables #100 - #299 become <empty> by the reset operation. 0: Emptied 1: Not emptied
	2	Output of leading zeros if the upper digit value of a variable is "0" at the execution of DPRINT function 0: Space are output. 1: Nothing is output.
	5	Automatic setting of tool coordinate memory No. by external input 0: Not executed 1: Executed
	6	Automatic clear of tool wear offset data by external input 0: Not executed 1: Executed
	7	MST status when operation mode is changed from automatic to manual 0: M, S, and T are forcibly finished without SPL indicating lamp lit. 1: M, S, and T are saved with SPL indicating lamp lit.
pm4010	0	Processing after the change of offset amount 0: New offset amount becomes valid from the block to be buffered next. 1: New offset amount becomes valid from the T code to be buffered next.
	2	Operation expression for the direct input of measured workpiece value 0: Present value saved temporarily – Keyed-in value 1: Keyed-in value – Present value saved temporarily
	3	Offset data input value check 0: Not executed 1: Executed (alarm if input value is greater than parameter set value)
	5	Offset movements 0: Executed in the block in which the offset command is designated 1: Executed in the block in which axis movement command is designated
	6	Processing of a "T0" command when the setting is "no T code output for T0" (pm5012 D6 = 1) 0: Only offset movements are executed. 1: An alarm occurs.
	7	Processing of T code after reset, coordinate system setting, or reference point return 0: Lower two (three) digits: 00 1: Lower two (three) digits: Saved

A2

A2

Appendix Table 2.2 Parameter Table (cont'd)

Parameter No.	Bit	Description
pm4011	0	Thread cutting in single block mode 0: Stops after the completion of thread cutting block; feed hold is disregarded. 1: Stops after the completion of the block next to the thread cutting block; the same processing for feed hold.
	1	Setting of stop position for feed hold during thread cutting 0: After chamfering, the tool returns to and stops at the start point. 1: The tool stops at the position where chamfering is completed.
	2	Validity of manual absolute function if there is no axis move command in the block where incremental amount is generated 0: Manual absolute function is valid. 1: Manual absolute function is not valid.
	3	Validity of manual absolute function if there is no axis move command in the block where incremental amount is not generated 0: Manual absolute function is valid. 1: Manual absolute function is not valid.
	4	Constant surface speed control for rapid traverse commands 0: Only in the block immediately before the cutting feed block 1: All blocks containing rapid traverse commands
	5	Coordinate values used for the calculation in the constant surface speed control mode 0: Coordinate values specified in a program 1: Coordinate values including tool position offset data
	6	Canceling the manually moved distance after reset, reference point return, execution of G50, and key setting up 0: Canceled 1: Not canceled
	7	Ignoring of the manual absolute function for the incremental commands. 0: Manual absolute function is not ignored. 1: Manual absolute function is ignored.

Appendix Table 2.2 Parameter Table (cont'd)

Parameter No.	Bit	Description
pm4012	0	Addition of workpiece shift distance at the setting of coordinate system by G50 or setting up by the [ORG] key. 0: Workpiece shift distance is added. 1: Workpiece shift distance is not added.
	1	Reversing of the input incremental value of the workpiece coordinate system shift distance 0: Not reversed 1: Reversed
	2	G50 coordinate system setting command specified in the G53 mode 0: Causes an alarm. 1: Executed
	3	Movement direction of the coordinate system origin when a positive workpiece shift distance is added 0: In the negative direction 1: In the positive direction
	4	Addition of workpiece coordinate system shift distance in automatic coordinate system setting 0: Added 1: Not added
	5	Canceling the G50 coordinate system by G52, G53, or T command in the G53 mode 0: Canceled 1: Not canceled
pm4013 Nose R offset	0	Start-up and cancel motion 0: Type B compensation method 1: Type A compensation method
	1	Switching point of offset direction (G41/G42) 0: Point of intersection 1: At the start and end points
	2	Processing after the offset amount is changed 0: New offset amount becomes valid from the end point. 1: New offset amount becomes valid from the start point.
	3	Availability of interference check function 0: Not provided 1: Provided
	4	Processing after the detection of interference 0: Automatic correction 1: Alarm
	5	Corner blocks 0: Not divided 1: Divided
	6	Execution of tool radius offset when control point is "0" 0: Not executed 1: Executed

A2

A2

Appendix Table 2.2 Parameter Table (cont'd)

Parameter No.	Bit	Description
pm4015	1	Allowable error range check for circular arc command 0: Not executed 1: Executed
	3	Error detection at the completion dwell 0: Error detection is OFF. 1: Error detection is ON.
	4	In-position check when the G code mode is changed to G00 (G00, G01 → G00) 0: In-position check is not executed. 1: In-position check is executed.
	5	G00 error detection during solid tap 0: G00 error detection is ON. 1: G00 error detection is OFF.
	6	Display of the peak value of synchronization error between the spindle and the hole machining axis during solid tap. 0: Not displayed 1: Displayed
	7	Approach speed for program restart 0: Jog feedrate 1: Rapid traverse
pm4016	3	Output of M05 for changing the spindle rotation direction (forward/reverse) at the hole bottom in the G74, G84 canned cycle 0: M05 is not output. 1: M05 is output.
pm4017	2	Spindle override during the execution of thread cutting or tapping cycle 0: Fixed at 100% 1: Fixed at the value read at the start of cycle
	4	C-axis clamp/unclamp processing in a hole-machining canned cycle 0: Not executed 1: Executed
	6	If the hole bottom level command cannot be designated in a hole-machining canned cycle 0: Does not cause an alarm. 1: Causes an alarm.
pm4019	1	Direction of X-coordinate axis in the polar coordinate system 0: Forward rotation direction 1: Reverse rotation direction
	2	C-axis command input 0: The same as the X-axis command input 1: Fixed to radius

Appendix Table 2.2 Parameter Table (cont'd)

Parameter No.	Bit	Description
pm4020	2	Backing up of the macro variable data during normal operation 0: Macro variable data is backed up. 1: Macro variable data is not backed up.
	4	Validity of tool selection macro execution on single block switch 0: Valid 1: Invalid
pm4021	2	Coordinate memory No. for the setting of a new tool coordinate system 0: Upper two digits 1: Lower two digits
	5	Zero return function of the external position data display when the new tool coordinate system setting function is valid 0: The zero return function is invalid. 1: The zero return function is valid.
	6	Check of the nose R wear offset data input value 0: Not checked 1: Checked and an alarm occurs if it is greater than the value set for pm4389
pm4022	0 - 4	Validity of reference point return (1st - 5th axis) 0: Invalid 1: Valid
pm4023	0	Designation of "G50 S" in the G97 mode 0: Invalid 1: Valid
pm4026	0	Execution of rough turning process for G71/G72 if no I and K commands are designated 0: Not executed 1: Executed assuming I = U and K = W, if I = K = 0
	1	In G71/G72 operation, if X and Z coordinate values differ between the start and end points 0: Causes alarm. 1: Imaginary point is calculated.
pm4027	1	Address "\$" in a program 0: Illegal character 1: The \$ word (address \$ and following numerical value) is skipped.

A2

A2

Appendix Table 2.2 Parameter Table (cont'd)

Parameter No.	Bit	Description
pm4028	0.1	Shift direction in the G17 plane in a hole-machining canned cycle (G861/G87)
		D1 D0
		0 0 +X
0 1 -X		
2.3	1 0 +Y	
	1 1 -Y	
	Shift direction in the G18 plane in a hole-machining canned cycle (G861/G87)	
	D1 D0	
4.5	0 0 +Z	
	0 1 -Z	
	1 0 +X	
	1 1 -X	
pm4029	1	Shift direction in the G19 plane in a hole-machining canned cycle (G861/G87)
		D1 D0
		0 0 +Y
		0 1 -Y
1	1 0 +Z	
	1 1 -Z	
	Setting of the tool group in the skip status	
	0: Presently selected tool group	
2	1: Tools in the specified tool group	
	Designation of the tool group to be reset	
	0: The tool group presently executed	
	1: Tools in the specified group	
3	In the use count designation, counting is executed	
	0: Only for the specified groups	
	1: For all use count designation groups	
	4	Clearing of tool kinds at the execution of tool file all clear processing
0: Cleared		
1: Not cleared		
pm4039		0
	0: New tool coordinate system	
		1: Workpiece coordinate system

Appendix Table 2.2 Parameter Table (cont'd)

Parameter No.	Bit	Description
pm5000	0	Valid timing of cycle start signal 0: Valid at "0" → "1" 1: Valid at "1" → "0"
	1	Output of rewind signal when rewinding NC program by the reset and rewind signal 0: Output 1: Not output
	2	Turning ON of RST output signal when ESP input signal is ON 0: Not turned ON 1: Turned ON
	3	Control of M00/M01 0: By ladder 1: By NC
	6	Occurrence of SOT 0: Causes alarm 1: Does not cause alarm
	7	Occurrence of overtravel 0: Causes alarm 1: Does not cause alarm
pm5013	0.1	Gear selection for H range D1 D0 0 0 Gear A 0 1 Gear A 1 0 Gear B
	2.3	Gear selection for M range D1 D0 0 0 Gear A 0 1 Gear A 1 0 Gear B
	4.5	Gear selection for L range D1 D0 0 0 Gear A 0 1 Gear A 1 0 Gear B

A2

A2

Appendix Table 2.2 Parameter Table (cont'd)

No.	Description	Setting Range	Unit
pm0100	Thread chamfering width	1 - 255	1 = 0.1 lead
pm0101	Thread chamfering angle	1 - 2	1 = 45°, 2 = 60°
pm0104	Time until the occurrence of ALM9022 (APL4 error) 0 : 489 ms 1 - 254 : 1 - 254 ms 255 : Waiting infinitely	0 - 255	
pm0109	Internal system number switch setting "0", "1"	0 - 255	
pm0400	Dwell period after C-axis unclamp in a hole-machining canned cycle	0 - 32767	1 = 1 ms
pm0402	Dwell period at the completion of in-feed in multiple repetitive cycle G74/G75	0 - 32767	1 = 1 ms
pm0405 - pm0408	Spindle phase shift amount in spindle phase synchronization, No. 1 - No. 4 spindles	-3600 - 3600	1 = 0.1 deg
pm0801	Break point sequence number setting (1)	1 - 99999	
pm0802	Break point sequence number setting (2)	1 - 99999	
pm0811 - pm0815	Coordinate values at skip signal input (1st - 5th axis)	0 - ± 999999999	1 = Minimum input unit
pm0831 - pm0833	No. 2 stored stroke limit, 1st - 3rd axis (+)	0 - ± 999999999	1 = Minimum detection unit
pm0834 - pm0836	No. 2 stored stroke limit, 1st - 3rd axis (-)	0 - ± 999999999	1 = Minimum detection unit
pm0837 - pm0839	No. 3 stored stroke limit, 1st - 3rd axis (+)	0 - ± 999999999	1 = Minimum detection unit
pm0840 - pm0842	No. 3 stored stroke limit, 1st - 3rd axis (-)	0 - ± 999999999	1 = Minimum detection unit
pm0843 - pm0845	No. 4 stored stroke limit, 1st - 3rd axis (+)	0 - ± 999999999	1 = Minimum detection unit
pm0846 - pm0848	No. 4 stored stroke limit, 1st - 3rd axis (-)	0 - ± 999999999	1 = Minimum detection unit
pm0849 - pm0851	No. 5 stored stroke limit, 1st - 3rd axis (+)	0 - ± 999999999	1 = Minimum detection unit
pm0852 - pm0854	No. 5 stored stroke limit, 1st - 3rd axis (-)	0 - ± 999999999	1 = Minimum detection unit
pm0860	Retraction amount (X-axis) after the in-feed in OD stock removal cycle (G71)	0 - 999999999	1 = 0.001 mm, 0.0001 inch
pm0861	Retraction amount (Z-axis) after the in-feed in OD stock removal cycle (G71)	0 - 999999999	1 = 0.001 mm, 0.0001 inch

Appendix Table 2.2 Parameter Table (cont'd)

No.	Description	Setting Range	Unit
pm0862	Retraction amount (X-axis) after the in-feed in face rough cutting cycle (G72)	0 - 999999999	1 = 0.001 mm, 0.0001 inch
pm0863	Retraction amount (Z-axis) after the in-feed in face rough cutting cycle (G72)	0 - 999999999	1 = 0.001 mm, 0.0001 inch
pm0864	Return amount in face cut-off cycle (G74)	0 - 999999999	1 = 0.001 mm, 0.0001 inch
pm0865	Return amount in OD cut-off cycle (G75)	0 - 999999999	1 = 0.001 mm, 0.0001 inch
pm0866	Depth of cut (X-axis) in the last cycle in automatic thread cutting cycle (G76)	0 - 999999999	1 = 0.001 mm, 0.0001 inch
pm0867	Return amount in grooving canned cycle (G74) (A ≠ 0)	0 - 999999999	1 = 0.001 mm, 0.0001 inch
pm0868	Return amount in grooving canned cycle (G75) (A ≠ 0)	0 - 999999999	1 = 0.001 mm, 0.0001 inch
pm1100 - pm1102	Servo axis display name (1st-axis)		Set by converting ASCII code into decimal
pm1103 - pm1105	Servo axis display name (2nd-axis)		Set by converting ASCII code into decimal
pm1106 - pm1108	Servo axis display name (3rd-axis)		Set by converting ASCII code into decimal
pm1109 - pm1111	Servo axis display name (4th-axis)		Set by converting ASCII code into decimal
pm1112 - pm1114	Servo axis display name (5th-axis)		Set by converting ASCII code into decimal
pm1127 - pm1129	Spindle display name (No. 1 spindle)		Set by converting ASCII code into decimal
pm1130 - pm1132	Spindle display name (No. 2 spindle)		Set by converting ASCII code into decimal
pm1133 - pm1135	Spindle display name (No. 3 spindle)		Set by converting ASCII code into decimal
pm1136 - pm1138	Spindle display name (No. 4 spindle)		Set by converting ASCII code into decimal
pm1142 - pm1144	Automatic system axis display name (1st-axis)		Set by converting ASCII code into decimal
pm1145 - pm1147	Automatic system axis display name (2nd-axis)		Set by converting ASCII code into decimal
pm1148 - pm1150	Automatic system axis display name (3rd-axis)		Set by converting ASCII code into decimal
pm1151 - pm1153	Automatic system axis display name (4th-axis)		Set by converting ASCII code into decimal
pm1154 - pm1156	Automatic system axis display name (5th-axis)		Set by converting ASCII code into decimal



Appendix Table 2.2 Parameter Table (cont'd)

No.	Description	Setting Range	Unit
pm1169 - pm1171	Spindle automatic system axis display name (No. 1 spindle)		Set by converting ASCII code into decimal
pm1172 - pm1174	Spindle automatic system axis display name (No. 2 spindle)		Set by converting ASCII code into decimal
pm1175 - pm1177	Spindle automatic system axis display name (No. 3 spindle)		Set by converting ASCII code into decimal
pm1178 - pm1180	Spindle automatic system axis display name (No. 4 spindle)		Set by converting ASCII code into decimal
pm1200	High-speed mode operation, number of controlled axes	3 - 5	3: 3 axes, 4: 4 axes, 5: 5 axes
pm1220 - pm1223	Spindle index confirmation timer (No. 1 - No. 4 spindle)	1 - 255	1 = 4 ms
pm1225 - pm1228	Spindle index stopped confirmation speed (No. 1 - No. 4 spindle)	1 - 255	1 = 1 r/min
pm1240	Axis number to execute solid tap (1)	1 - 4	
pm1241	Servo axis number to execute solid tap (1)	1 - 8	
pm1242	Axis number to execute solid tap (2)	1 - 4	
pm1243	Servo axis number to execute solid tap (2)	1 - 8	
pm1244	Spindle No. A to execute rotary tool spindle synchronization (1)	1 - 4	
pm1245	Spindle No. B to execute rotary tool spindle synchronization (1)	1 - 4	
pm1246	Spindle No. A to execute rotary tool spindle synchronization (2)	1 - 4	
pm1247	Spindle No. B to execute rotary tool spindle synchronization (2)	1 - 4	
pm1248	Spindle No. A to execute back-turning spindle synchronization (1)	1 - 4	
pm1249	Spindle No. B to execute back-turning spindle synchronization (1)	1 - 4	
pm1250	Spindle No. A to execute back-turning spindle synchronization (2)	1 - 4	
pm1251	Spindle No. B to execute back-turning spindle synchronization (2)	1 - 4	
pm1252	Solid tap (1) return feedrate multiplication ratio	1 - 255	1 = 0.1 times
pm1253	Solid tap (2) return feedrate multiplication ratio	1 - 255	1 = 0.1 times
pm1254	Error range of back-turning spindle synchronization (1)	0 - 255	1 = 1 Minimum detection unit

Appendix Table 2.2 Parameter Table (cont'd)

No.	Description	Setting Range	Unit
pm1255	Offset parameter of back-turning spindle synchronization (1)	0 - 255	1 = 0.1
pm1256	Error range of back-turning spindle synchronization (2)	0 - 255	1 = 1 Minimum detection unit
pm1257	Offset parameter of back-turning spindle synchronization (2)	0 - 255	1 = 0.1
pm1260	No. 1 spindle, loop control gear number (A)	0 - 4	
pm1261	No. 1 spindle, loop control gear number (B)	0 - 4	
pm1262	No. 2 spindle, loop control gear number (A)	0 - 4	
pm1263	No. 2 spindle, loop control gear number (B)	0 - 4	
pm1321 - pm1325	1st - 5th axis, error detect on area	0 - 255	1 = Minimum input unit
pm1331 - pm1334	No. 1 - No. 4 spindle, error detection on area in loop control	0 - 255	1 = Minimum input unit
pm1347	Multiplication ratio to rapid traverse rate in C1 (No. 1 C-axis) servo error area	0 - 200	1 = 1%
pm1348	Multiplication ratio to rapid traverse rate in C2 (No. 2 C-axis) servo error area	0 - 200	1 = 1%
pm1351 - pm1354	In No. 1 - No. 4 spindle loop control, spindle speed multiplication ratio in solid tapping in servo error area	0 - 200	1 = 1%
pm1361 - pm1364	No. 1 - No. 4 torque meter display upper limit value	0 - 200	1 = 1% (10% unit??)
pm1400 - pm1403	No. 1 spindle, spindle speed clamp (minimum) for gear 1 - gear 4	0 - 30000	1 = 1 r/min, 10 r/min
pm1404 - pm1407	No. 1 spindle, spindle speed clamp (maximum) for gear 1 - gear 4	0 - 30000	1 = 1 r/min, 10 r/min
pm1408 - pm1411	No. 1 spindle, maximum motor speed for gear 1 - gear 4	0 - 30000	1 = 1 r/min, 10 r/min
pm1412	No. 1 spindle, spindle speed in response to the input of spindle fixed speed (GSC) signal	0 - 32767	1 = 1 r/min
pm1413	No. 1 spindle, output voltage in response to the spindle gear shift (GSC) signal	0 - 32767	1 = 10/32767 V
pm1414	No. 1 spindle, origin for indexing	0 - 4095	1 = 360/4096 deg
pm1415	No. 1 spindle, spindle speed corresponding to 10 V command in the gear range used for solid tap	0 - 32767	1 = 1 r/min, 10 r/min
pm1416	No. 1 spindle, maximum spindle speed during solid tap	0 - 32767	1 = 1 r/min, 10 r/min
pm1417	No. 1 spindle, position loop gain in spindle indexing for solid tap 1	0 - 32767	1 = 0.01 [S ⁻¹]
pm1418	No. 1 spindle, maximum spindle speed corresponding to 10 V command (C-axis is used)	0 - 32767	1 = 1 r/min
pm1420 - pm1422	No. 2 spindle, spindle speed clamp (minimum) for gear 1 - gear 4	0 - 30000	1 = 1 r/min, 10 r/min

A2

A2

Appendix Table 2.2 Parameter Table (cont'd)

No.	Description	Setting Range	Unit
pm1424 - pm1426	No. 2 spindle, spindle speed clamp (maximum) for gear 1 - gear 4	0 - 30000	1 = 1 r/min, 10 r/min
pm1428 - pm1431	No. 2 spindle, maximum motor speed for gear 1 - gear 4	0 - 30000	1 = 1 r/min, 10 r/min
pm1432	No. 2 spindle, spindle speed in response to the input of spindle fixed speed (GSC) signal	0 - 32767	1 = 1 r/min
pm1433	No. 2 spindle, output voltage in response to the spindle gear shift (GSC) signal	0 - 32767	1 = 10/32767 V
pm1434	No. 2 spindle, origin for indexing	0 - 4095	1 = 360/4096 deg
pm1435	No. 2 spindle, spindle speed corresponding to 10 V command in the gear range used for solid tap	0 - 32767	1 = 1 r/min, 10 r/min
pm1436	No. 2 spindle, maximum spindle speed during solid tap	0 - 32767	1 = 1 r/min, 10 r/min
pm1437	No. 2 spindle, position loop gain in spindle indexing for solid tap 1	0 - 32767	1 = 0.01 [S ⁻¹]
pm1438	No. 2 spindle, maximum spindle speed corresponding to 10 V command (C-axis is used)	0 - 32767	1 = 1 r/min
pm1440 - pm1443	No. 3 spindle, spindle speed clamp (minimum) for gear 1 - gear 4	0 - 30000	1 = 1 r/min, 10 r/min
pm1444 - pm1447	No. 3 spindle, spindle speed clamp (maximum) for gear 1 - gear 4	0 - 30000	1 = 1 r/min, 10 r/min
pm1448 - pm1451	No. 3 spindle, maximum motor speed for gear 1 - gear 4	0 - 30000	1 = 1 r/min, 10 r/min
pm1452	No. 3 spindle, spindle speed in response to the input of spindle orientation (SOR) signal	0 - 32767	1 = 1 r/min
pm1453	No. 3 spindle, motor speed in response to the spindle gear shift (SRO) signal	0 - 32767	1 = 10/32767 V
pm1454	No. 3 spindle, origin for indexing	0 - 4095	1 = 360/4096 deg
pm1460 - pm1463	No. 4 spindle, spindle speed clamp (minimum) for gear 1 - gear 4	0 - 30000	1 = 1 r/min, 10 r/min
pm1464 - pm1467	No. 4 spindle, spindle speed clamp (maximum) for gear 1 - gear 4	0 - 30000	1 = 1 r/min, 10 r/min
pm1468 - pm1471	No. 4 spindle, maximum motor speed for gear 1 - gear 4	0 - 30000	1 = 1 r/min, 10 r/min
pm1472	No. 4 spindle, spindle speed in response to the input of spindle orientation (SOR) signal	0 - 32767	1 = 1 r/min
pm1473	No. 4 spindle, motor speed in response to the spindle gear shift (SRO) signal	0 - 32767	1 = 10/32767 V

Appendix Table 2.2 Parameter Table (cont'd)

No.	Description	Setting Range	Unit
pm1474	No. 4 spindle, origin for indexing	0 - 4095	1 = 360/4096 deg
pm1480 - pm1483	No. 1 spindle, spindle speed clamp (minimum) for gear 5 - gear 8	0 - 30000	1 = 1 r/min, 10 r/min Note: According to the setting for pm1002 D0
pm1484 - pm1487	No. 1 spindle, spindle speed clamp (maximum) for gear 5 - gear 8	0 - 30000	1 = 1 r/min, 10 r/min Note: According to the setting for pm1002 D0
pm1488 - pm1491	No. 1 spindle, maximum motor speed for gear 5 - gear 8	0 - 30000	1 = 1 r/min, 10 r/min Note: According to the setting for pm1002 D0
pm1492 - pm1495	Spindle position loop gain in spindle synchronization control (No. 1 - No. 4 spindle)	0 - 32767	1 = 0.01 [S ⁻¹]
pm1496	Error range in rotary tool spindle synchronization control (1)	0 - 32767	1 = 1 pulse
pm1497	Error range in rotary tool spindle synchronization control (2)	0 - 32767	1 = 1 pulse
pm1500	Solid tap (1), servo axis drawing-in in-position width	0 - 32767	1 = Minimum input unit
pm1501	Solid tap (2), servo axis drawing-in in-position width	0 - 32767	1 = Minimum input unit
pm1502	Solid tap (1), synchronization offset parameter K1	-32767 - 32767	
pm1503	Solid tap (1), synchronization offset parameter K2	-32767 - 32767	
pm1504	Solid tap (2), synchronization offset parameter K1	-32767 - 32767	
pm1505	Solid tap (2), synchronization offset parameter K2	-32767 - 32767	
pm1506	Rotary tool spindle (1), synchronization offset parameter K1'	-32767 - 32767	
pm1507	Rotary tool spindle (1), synchronization offset parameter K2'	-32767 - 32767	
pm1508	Rotary tool spindle (2), synchronization offset parameter K1'	-32767 - 32767	
pm1509	Rotary tool spindle (2), synchronization offset parameter K2'	-32767 - 32767	
pm1510	No. 1 spindle, the number of teeth of gear A at the spindle side used in loop control	0 - 32767	1 = 1 tooth Note: "9" if intermediate gear is not used.
pm1511	No. 1 spindle, the number of teeth of gear A of spindle intermediate gear in loop control Note: The number of teeth on the motor side if intermediate gear is not used.	0 - 32767	
pm1512	No. 1 spindle, the number of teeth of gear A of intermediate gear in loop control Note: "0" if intermediate gear is not used.	0 - 32767	

A2

A2

Appendix Table 2.2 Parameter Table (cont'd)

No.	Description	Setting Range	Unit
pm1513	No. 1 spindle, the number of teeth of gear A at the motor side used in loop control Note: "0" if intermediate gear is not used.	0 - 32767	
pm1514	No. 1 spindle, the number of teeth of gear B at the spindle side used in loop control Note: "0" if intermediate gear is not used.	0 - 32767	
pm1515	No. 1 spindle, the number of teeth of gear B of spindle intermediate gear in loop control Note: "0" if intermediate gear is not used.	0 - 32767	
pm1516	No. 1 spindle, the number of teeth of gear B of intermediate gear in loop control Note: "0" if intermediate gear is not used.	0 - 32767	
pm1517	No. 1 spindle, the number of teeth of gear B at the motor side used in loop control Note: "0" if intermediate gear is not used.	0 - 32767	
pm1518	No. 2 spindle, the number of teeth of gear A at the spindle side used in loop control	0 - 32767	1 = 1 tooth Note: "9" if intermediate gear is not used.
pm1519	No. 2 spindle, the number of teeth of gear A of spindle intermediate gear in loop control Note: The number of teeth on the motor side if intermediate gear is not used.	0 - 32767	
pm1520	No. 2 spindle, the number of teeth of gear A of intermediate gear in loop control	0 - 32767	
pm1521	No. 2 spindle, the number of teeth of gear A at the motor side used in loop control	0 - 32767	
pm1522	No. 2 spindle, the number of teeth of gear B at the spindle side used in loop control	0 - 32767	
pm1523	No. 2 spindle, the number of teeth of gear B of spindle intermediate gear in loop control	0 - 32767	
pm1524	No. 2 spindle, the number of teeth of gear B of intermediate gear in loop control	0 - 32767	
pm1525	No. 2 spindle, the number of teeth of gear B at the motor side used in loop control	0 - 32767	
pm1539	Output error range in spindle synchronization control	0 - 32767	
pm1540 - pm1543	No. 1 - No. 4 spindle, delay time to check the spindle speed arrived signal (SAGR)	0 - 32767	1 = 1 ms
pm1544	Spindle phase synchronization offset clamp value	0 - 32767	1 = Minimum detection unit
pm1551 - pm1555	1st - 5th axis, backlash compensation amount	0 - 32767	1 = 1 μ M
pm1580	1st axis, position loop gain Kp	500 - 20000	1 = 0.01 [1/s]

Appendix Table 2.2 Parameter Table (cont'd)

No.	Description	Setting Range	Unit
pm1581	1st axis, velocity loop gain Kv	350 - 32767	1 = 0.1 [1/s]
pm1582	1st axis, velocity loop integration time constant Ti	1 - 32767	1 = 0.01 [ms]
pm1584	1st axis, velocity feed forward gain Kvfff	0 - 100	1 = 0.01 [%] 1 = 1%
pm1586	1st axis, axis torsion filter time constant (for the 1st step) Tn	1 - 32767	1 = 0.01 [ms]
pm1587	1st axis, axis torsion filter time constant (for the 2nd step) Tn	1 - 32767	1 = 0.01 [ms]
pm1588	1st axis, axis torsion filter time constant (for the 3rd step) Tn	1 - 32767	1 = 0.01 [ms]
pm1589	1st axis, monitor board signal selection, multiplication ratio	1 - 32767	
pm1590	2nd axis, position loop gain Kp	500 - 20000	1 = 0.01 [1/s]
pm1591	2nd axis, velocity loop gain Kv	350 - 32767	1 = 0.1 [1/s]
pm1592	2nd axis, velocity loop integration time constant Ti	1 - 32767	1 = 0.01 [ms]
pm1594	2nd axis, velocity feed forward gain Kvfff	0 - 100	1 = 0.01 [%] 1 = 1%
pm1596	2nd axis, axis torsion filter time constant (for the 1st step) Tn	1 - 32767	1 = 0.01 [ms]
pm1597	2nd axis, axis torsion filter time constant (for the 2nd step) Tn	1 - 32767	1 = 0.01 [ms]
pm1598	2nd axis, axis torsion filter time constant (for the 3rd step) Tn	1 - 32767	1 = 0.01 [ms]
pm1599	2nd axis, monitor board signal selection, multiplication ratio	1 - 32767	
pm1600	3rd axis, position loop gain Kp	500 - 20000	1 = 0.01 [1/s]
pm1601	3rd axis, velocity loop gain Kv	350 - 32767	1 = 0.1 [1/s]
pm1602	3rd axis, velocity loop integration time constant Ti	1 - 32767	1 = 0.01 [ms]
pm1604	3rd axis, velocity feed forward gain Kvfff	0 - 100	1 = 0.01 [%] 1 = 1%
pm1606	3rd axis, axis torsion filter time constant Tn	1 - 32767	1 = 0.01 [ms]
pm1606	3rd axis, axis torsion filter time constant (for the 1st step) Tn	1 - 32767	1 = 0.01 [ms]
pm1607	3rd axis, axis torsion filter time constant (for the 2nd step) Tn	1 - 32767	1 = 0.01 [ms]
pm1608	3rd axis, axis torsion filter time constant (for the 3rd step) Tn	1 - 32767	1 = 0.01 [ms]
pm1610	4th axis, position loop gain Kp	500 - 20000	1 = 0.01 [1/s]
pm1611	4th axis, velocity loop gain Kv	350 - 32767	1 = 0.1 [1/s]
pm1612	4th axis, velocity loop integration time constant Ti	1 - 32767	1 = 0.01 [ms]
pm1614	4th axis, velocity feed forward gain Kvfff	0 - 100	1 = 0.01 [%] 1 = 1%
pm1616	4th axis, axis torsion filter time constant (for the 1st step) Tn	1 - 32767	1 = 0.01 [ms]
pm1617	4th axis, axis torsion filter time constant (for the 2nd step) Tn	1 - 32767	1 = 0.01 [ms]
pm1618	4th axis, axis torsion filter time constant (for the 3rd step) Tn	1 - 32767	1 = 0.01 [ms]

A2

Appendix Table 2.2 Parameter Table (cont'd)

No.	Description	Setting Range	Unit
pm1619	4th axis, monitor board signal selection, multiplication ratio	1 - 32767	
pm1620	5th axis, position loop gain Kp	500 - 20000	1 = 0.01 [1/s]
pm1621	5th axis, velocity loop gain Kv	350 - 32767	1 = 0.1 [1/s]
pm1622	5th axis, velocity loop integration time constant Ti	1 - 32767	1 = 0.01 [ms]
pm1624	5th axis, velocity feed forward gain Kvfff	0 - 100	1 = 0.01 [%] 1 = 1%
pm1626	5th axis, axis torsion filter time constant (for the 1st step) Tn	1 - 32767	1 = 0.01 [ms]
pm1627	5th axis, axis torsion filter time constant (for the 2nd step) Tn	1 - 32767	1 = 0.01 [ms]
pm1628	5th axis, axis torsion filter time constant (for the 3rd step) Tn	1 - 32767	1 = 0.01 [ms]
pm1629	5th axis, monitor board signal selection, multiplication ratio	1 - 32767	
pm1671 - pm1675	1st - 5th axis, torque limit (+)	1 - 32767	1 = 1 [%]
pm1711 - pm1715	1st - 5th axis, backlash time constant	1 - 32767	1 = 0.01 [ms]
pm1720	Torque limit arrived signal output timer		
pm1721 - pm1725	1st - 5th axis, torque limit value 1	1 - 32767	1 = 1 [%]
pm1731 - pm1735	1st - 5th axis, torque limit value 2	1 - 32767	1 = 1 [%]
pm1761 - pm1765	1st - 5th axis, disturbance limiter value for rapid traverse	1 - 32767	1 = 1 %
pm1771 - pm1775	1st - 5th axis, disturbance limiter value for forced input	1 - 32767	1 = 1 %
pm1811 - pm1814	No. 1 - No. 4 spindle, spindle offset amount in spindle phase synchronization control	0 - 360000	1 = Minimum input unit
pm1821 - pm1825	1st - 5th axis, axis move distance per 1 turn of motor	0 - 99999999	1 = 0.001 mm or 0.001 deg
pm1831 - pm1835	1st - 5th axis, ratio of inertia of load to motor inertia	0 - 32767	1 = 1 [%]
pm1841 - pm1845	1st - 5th axis, number of pulses per 1 turn of motor	0 - 99999999	1 = 1 pulse
pm1849	Travel distance for indexing between 1st C-axis and C-axis (C-axis integral with the spindle)	0 - 99999999	Detection unit
pm1850	Travel distance for indexing between 2nd C-axis and C-axis (C-axis integral with the spindle)	0 - 99999999	Detection unit
pm1851 - pm1855	C-phase pulse interval of 1st - 5th virtual C-phase (valid when pm1044 - pm1048 D5 = 1)	0 - 99999999	
pm2400 - pm2431	Feedrate corresponding to the JOG FEEDRATE setting position, 0 - 31	0 - 32767	1 = 1 mm/min, 0.1 inch/min, 1 deg/min
pm2432	Multiplication of jog feedrate parameter value by 10 or 100	1, 10, 100	1 = ×1
pm2433	Designation of the addition start switch position if pm2432 ≠ 0	1 - 31	

Appendix Table 2.2 Parameter Table (cont'd)

No.	Description	Setting Range	Unit
pm2434	Designation of position where the jog feedrate parameter value is multiplied by 1/10	1 - 31	
pm2440 - pm2442	Feedrate for the execution of skip (1) - (3)	0 - 32767	1 = 1 mm/min, 0.1 inch/min, 1 deg/min
pm2443	Feedrate in the execution of deviation skip	0 - 32767	1 = 1 mm/min, 0.1 inch/min, 1 deg/min
pm2447	Feedrate for rapid traverse override F ₀	0 - 32767	1 = 1 mm/min, 0.1 inch/min, 1 deg/min (prn2000 D3 = 0) 1 = 1% (prn2000 D3 = 1)
pm2448	Feedrate for rapid traverse override F ₁	0 - 100	1 = 1 %
pm2449	Feedrate for rapid traverse override F ₂	0 - 100	1 = 1 %
pm2459	Multiplication value for ×100 position of manual pulse multiply switch	0 - 32767	1 = ×1
pm2461 - pm2465	1st - 5th axis, rapid traverse acceleration/deceleration time constant (1st step)	0 - 32767	1 = 1 ms
pm2471 - pm2474	No. 1 - No. 4 spindle, linear acceleration/deceleration time constant	4 - 32767	1 = 1 ms
pm2476 - pm2479	No. 1 - No. 4 spindle, exponential acceleration/deceleration time constant	4 - 32767	1 = 1 ms
pm2501 - pm2505	1st - 5th axis, exponential acceleration/deceleration time constant in normal cutting	0 - 32767	1 = 1 ms
pm2511 - pm2515	1st - 5th axis, exponential acceleration/deceleration time constant in thread cutting	0 - 32767	1 = 1 ms
pm2521 - pm2525	1st - 5th axis, reference point return approach speed	0 - 32767	1 = 1 mm/min, 0.1 inch/min, 1 deg/min
pm2531 - pm2535	1st - 5th axis, reference point return creep speed	15 - 32767	1 = 1 mm/min, 0.1 inch/min, 1 deg/min
pm2541 - pm2544	No. 1 - No. 4 spindle, index start speed	1 - 32767	1 = 1 r/min
pm2546 - pm2549	No. 1 - No. 4 spindle, index creep speed	1 - 32767	1 = 1 r/min
pm2561 - pm2565	1st - 5th axis, acceleration/deceleration time constant in handle feed	0 - 32767	1 = 1 ms
pm2584	Spindle feedback pulse sampling delay offset coefficient	0 - 10	

A2

Appendix Table 2.2 Parameter Table (cont'd)

No.	Description	Setting Range	Unit
pm2591 - pm2595	1st - 5th axis, S-curve factor in rapid traverse acceleration/deceleration	0 - 6	
pm2800	Maximum cutting feedrate (linear axis)	0 - 240000	1 = 1 mm/min, 0.1 inch/min
pm2801 - pm2805	1st - 5th axis, rapid traverse rate	0 - 240000	1 = 1 mm/min, 0.1 inch/min,
pm2821 - pm2825	1st - 5th axis, bias in normal acceleration/deceleration	0 - 240000	1 = 1 mm/min, 0.1 inch/min, 1 deg/min
pm2831 - pm2835	1st - 5th axis, bias in thread cutting acceleration/deceleration	0 - 240000	1 = 1 mm/min, 0.1 inch/min, 1 deg/min
pm2860	Maximum feedrate in handle feed (linear axis)	0 - 240000	1 = 1mm/min, 0.1 inch/min
pm2861	Maximum feedrate in handle feed (rotary axis)	0 - 240000	1 = 1deg/min
pm2863	Number of servo lag pulses for feed clamp in handle feed operation	0 - 240000	1 = 1 pulse
pm2864	Shift feedrate in G861/G87 hole-machining canned cycle	0 - 240000	1 = 1 mm/min, 0.1 inch/min
pm3108 - pm3108?	Designation of DNC high-speed cutting data start character	Example: G → 47H	Hexadecimal ASCII code
pm3400 - pm3409	Title display at power on, 1st line, 1 - 10 columns		Set by converting ASCII code into decimal
pm3410 - pm3419	Title display at power on, 2nd line, 1 - 10 columns		Set by converting ASCII code into decimal
pm3420	Title display, magnification ratio	1st digit: Magnification for the 1st line (1 - 3) 2nd digit: Magnification for the 2nd line (1 - 3)	2-digit value is assumed to be a hexadecimal number; convert it into decimal for setting.
pm3421	Title display, display start position	1st and 2nd digits: 1st line start position (1 - 39) 3rd and 4th digits: 2nd line start position (1 - 39)	2-digit value is assumed to be a hexadecimal number; convert it into decimal for setting.
pm3440	“RDI” command PLC battery backed-up memory number designation	7000 - 7999	
pm3441	“SOD” command PLC battery backed-up memory number designation	7000 - 7999	

Appendix Table 2.2 Parameter Table (cont'd)

No.	Description	Setting Range	Unit
pm4100	Punched hole pattern, in EIA code, of special characters used in user macro, #	0 - 255	Hole pattern is regarded as a binary number; convert it into decimal for setting.
pm4101	Punched hole pattern, in EIA code, of special characters used in user macro, [0 - 255	Hole pattern is regarded as a binary number; convert it into decimal for setting.
pm4102	Punched hole pattern, in EIA code, of special characters used in user macro,]	0 - 255	Hole pattern is regarded as a binary number; convert it into decimal for setting.
pm4103	Punched hole pattern, in EIA code, of special characters used in user macro, *	0 - 255	Hole pattern is regarded as a binary number; convert it into decimal for setting.
pm4104	Punched hole pattern, in EIA code, of special characters used in user macro, =	0 - 255	Hole pattern is regarded as a binary number; convert it into decimal for setting.
pm4105	Punched hole pattern, in EIA code, of special characters used in user macro, (0 - 255	Hole pattern is regarded as a binary number; convert it into decimal for setting.
pm4106	Punched hole pattern, in EIA code, of special characters used in user macro,)	0 - 255	Hole pattern is regarded as a binary number; convert it into decimal for setting.
pm4107	Punched hole pattern, in EIA code, of special characters used in user macro, .	0 - 255	Hole pattern is regarded as a binary number; convert it into decimal for setting.
pm4108	Punched hole pattern, in EIA code, of special characters used in user macro, ,	0 - 255	Hole pattern is regarded as a binary number; convert it into decimal for setting.
pm4109	Punched hole pattern, in EIA code, of special characters used in user macro, " "	0 - 255	Hole pattern is regarded as a binary number; convert it into decimal for setting.
pm4110	Tool life control group command T code offset	Tool life control group (0 - 9) =T command - pm4110 × 1000	
pm4144	Punched hole pattern, in EIA code, of special characters used in user macro, <	0 - 255	Hole pattern is regarded as a binary number; convert it into decimal for setting.
pm4145	Punched hole pattern, in EIA code, of special characters used in user macro, >	0 - 255	Hole pattern is regarded as a binary number; convert it into decimal for setting.
pm4146	Punched hole pattern, in EIA code, of special characters used in user macro, ;	0 - 255	Hole pattern is regarded as a binary number; convert it into decimal for setting.

A2

A2

Appendix Table 2.2 Parameter Table (cont'd)

No.	Description	Setting Range	Unit
pm4400 - pm4409	Buffering stop M code (1) - (10)	0 - 9999	
pm4430 - pm4432	Spindle forward rotation M code used for hole-machining canned cycle	0 - 9999	
pm4439	C-axis clamp M code used for hole-machining canned cycle	0 - 9999	
pm4440 - pm4445	C-axis unclamp M code used for hole-machining canned cycle	0 - 9999	
pm4450	Small arc skip value in nose R and tool radius offset mode	0 - 32767	1 = Minimum input unit
pm4451 - pm4455	1st - 5th axis, reference point return distance	0 - 32767	1 = 0.001 mm, 0.0001 inch, 0.001 deg
pm4471 - pm4475	1st - 5th axis, external workpiece coordinate system shift offset amount	0 - 32767	1 = 0.001 mm, 0.0001 inch, 0.001 deg
pm4480 - pm4503	G code macro (1 - 24) call G code	1 - 999	
pm4504 - pm4527	M code macro (1 - 24) call M code	1 - 9999	
pm4532 - pm4537	M codes valid in the auxiliary function lock mode (according to the setting for setting parameter pm0001 D7)	0 - 999	
pm4551 - pm4555	Virtual C-phase shift distance, 1st - 5th axis	-32767 - 32767	1 = 0.001 mm, 0.0001 inch, 0.001 deg
pm4801 - pm4805	1st - 5th axis, automatic coordinate system in "mm" input	0 - ±999999999	1 = Minimum input unit in "mm" system
pm4811 - pm4815	1st - 5th axis, automatic coordinate system in "inch" input	0 - ±999999999	1 = Minimum input unit in "inch" system
pm4820	Allowable error range in circular arc interpolation by R command	0 - 999999999	1 = Minimum input unit
pm4821 - pm4825	1st - 5th axis, maximum value for inputting incremental offset amount	0 - ±999999999	1 = Minimum input unit
pm4839	Maximum input value of tool nose R wear amount (absolute value)	0 - ±999999999	1 = Minimum input unit
pm4840 - pm4863	G code macro (1 - 24) call program number	1 - 99999	
pm4864 - pm4887	M code macro (1 - 24) call program number	1 - 99999	
pm4889	T code macro call designation	"0" or call program number	
pm5400	Duration of time from resetting of signal for turning servo power off to brake release at servo power ON	0 - 32767	1 = 1 ms
pm5401 - pm5405	1st - 5th axis, duration of time from ESP signal (normally closed) rising edge to base block ON	0 - 32767	1 = 1 ms

Appendix Table 2.2 Parameter Table (cont'd)

No.	Description	Setting Range	Unit
pm5410	Duration of time from sending M, T code to sending of MF, TF	0 - 32767	1 = 1 ms
pm5411	Skip monitor timer	1 - 255	1 = 1 ms
pm5412	Start number of battery backed-up memory used for I/O link data	7000 - 7999	
pm5420	Software switch, input battery backed-up memory start number	7000 - 7999	
pm5421	Software switch, output battery backed-up memory start number	7000 - 7999	
pm6101 - pm6105	1st - 5th axis, pitch error compensation magnification ratio	0 - 3	
pm6111 - pm6113	No. 2 stored stroke limit check axis designation, 1 - 3	0 - 3	1 = X-axis, 2 = Y-axis, 3 = Z-axis
pm6114 - pm6116	No. 3 stored stroke limit check axis designation, 1 - 3	0 - 3	
pm6117 - pm6119	No. 4 stored stroke limit check axis designation, 1 - 3	0 - 3	
pm6120 - pm6122	No. 5 stored stroke limit check axis designation, 1 - 3	0 - 3	
pm6401 - pm6405	1st - 5th axis, pitch error compensation data storing memory start number		
pm6411 - pm6415	1st - 5th axis, pitch error compensation data storing memory end number		
pm6421 - pm6425	1st - 5th axis, memory number storing the reference point for pitch error compensation		
pm6801 - pm6805	1st - 5th axis, pitch error compensation intervals	0 - 999999999	1 = 0.001 mm, 0.0001 inch, 0.001 deg
pm6811 - pm6815	1st - 5th axis, second reference point position	0 - ±999999999	1 = 0.001 mm, 0.0001 inch, 0.001 deg
pm6821 - pm6825	1st - 5th axis, third reference point position	0 - ±999999999	1 = 0.001 mm, 0.0001 inch, 0.001 deg
pm6831 - pm6835	1st - 5th axis, fourth reference point position	0 - ±999999999	1 = 0.001 mm, 0.0001 inch, 0.001 deg
pm6901 - pm6905	1st - 5th axis, stored stroke limit (+)	0 - ±999999999	1 = 0.001 mm, 0.0001 inch, 0.001 deg
pm6911 - pm6915	1st - 5th axis, stored stroke limit (-)	0 - ±999999999	1 = 0.001 mm, 0.0001 inch, 0.001 deg

A2

A2

Appendix Table 2.2 Parameter Table (cont'd)

No.	Description	Setting Range	Unit
pm6920	X-axis workpiece shift offset amount	-999999999 - 999999999	1 = 0.001 mm
pm6921	Offset amount of workpiece shift amount measuring tool	-999999999 - 999999999	1 = 0.001 mm
pm6922 - pm6925	Parameters (1) - (4) for direct input of workpiece measurement value Distance from the reference tool nose position to the X1 - X4 contact surface	-999999999 - 999999999	1 = 0.001 mm
pm6926	X-axis barrier area setting value (in diameter)	-999999999 - 999999999	1 = 0.001 mm
pm6927	Z-axis barrier area setting value (in diameter)	-999999999 - 999999999	1 = 0.001 mm
pm6928	Amount to be added for Z-axis workpiece coordinate system shift amount automatic determination	-999999999 - 999999999	1 = 0.001 mm
pm8401 - pm8405	1st - 5th axis, reference point fine adjustment amount used for absolute position detection function	-32768 - 32767	1 = 0.001 mm, 0.001 deg
pm8411 - pm8415	1st - 5th axis, positional deviation limit value at power ON for absolute position detection function	0 - 32767	1 = 0.001 mm, 0.001 deg
pm8431 - pm8435	1st - 5th axis, current loop cut-off frequency offset	-00 - +500	1 = 1 Hz
pm8441 - pm8445	1st - 5th axis, U-phase current offset value	-00 - +500	
pm8451 - pm8455	1st - 5th axis, V-phase current offset value	-00 - +500	
pm8461 - pm8465	1st - 5th axis, servo pack type parameter Note: Must be "0" when analog amplifier is used.	0 - 7	
pm8471 - pm8475	1st - 5th axis, disturbance observer time constant	1 - 32768	
pm8481 - pm8485	1st - 5th axis, inertia fine adjustment amount for disturbance observer	-32768 - 32767	1 = 0.01 kg-m ²
pm8491 - pm8495	1st - 5th axis, presumed disturbance filter time constant	1 - 32768	
pm8501 - pm8505	1st - 5th axis, disturbance limiter value applied to other than rapid traverse	1 - 32767	1 = 1%
pm8511 - pm8515	1st - 5th axis, axis draw-back torque	1 - 32767	1 = 1%
pm8521 - pm8525	1st - 5th axis, gravity compensation torque	-32768 - 32767	1 = 0.01 (%)
pm8801 - pm8805	1st - 5th axis, machine position at power OFF	0 - ± 999999999	1 = 0.001 mm, 0.001 deg
pm8811 - pm8815	1st - 5th axis, offset amount when setting the origin of absolute position detection function	0 - ± 999999999	1 = 1 pulse
pm8821 - pm8825	1st - 5th axis, shift amount of absolute position detection function reference point	0 - ± 999999999	1 = 0.001 mm, 0.001 deg

APPENDIX 3

ALARM TABLE

Appendix 3 describes the classification and contents of alarms.

A3

3.1 CLASSIFICATION OF ALARMS	A3 - 2
3.2 ALARM TABLE	A3 - 3

APPENDIX 3.1 CLASSIFICATION OF ALARMS

Appendix Table 3.1 Classification of Alarms

No.	Contents	Stop Mode	Output	How to Reset
0000 - 0049	Errors related with edit and operation Occurring in the background mode also.	Block stop	Input error alarm	Reset
0050 - 0099	Errors related with edit and operation Not occurring in the background mode.	Block stop	Input error alarm	Reset Power OFF for #0050 and #0051
0100 - 0499	Program error (occurring in a series)	Block stop	Input error alarm	Reset
1000 - 1099	Program error (occurring over multiple series) DNC, COMS total, etc.	Block stop	Input error alarm	Reset
2000 - 2199	Machine related error OT, reference point return, machine ready, in-position, etc.	Stop after deceleration, or immediate stop	Alarm	Reset operation after removing the cause. With the alarm caused by the machine ready signal, if it occurs in the first power ON operation, it is automatically reset.
3000 - 3299	Servo and spindle related alarm ESP, CPU mutual monitoring in NC	Immediate stop, or servo off	Alarm	Reset after removing the cause. With the SVOFF alarm, it is automatically reset by the SVON.
8000 - 8049	Memory check error (ROM, RAM) Watchdog timer error Offline error	Immediate stop, or servo off	Alarm	For maintenance CPU halt Switching to the special maintenance screen
9000 - 9049	Error occurring in background editing (basically the same as with 0000 - 0049)	Not stopped	Background error output	Reset or with reset soft-key
BAT indication BAT. AXIS	Battery error Encoder alarm	Not stopped	No output	Changing the battery
Warning message	Key operation error, edit operation error (not serious operation error)	Not stopped	Warning	Next key operation

A3

APPENDIX 3.2 ALARM TABLE

Appendix Table 3.2 Alarm Table

Alarm No.	Description
0010	In tape mode operation, TH parity error has occurred.
0011	In tape mode operation, TV parity error has occurred.
0012	In tape mode operation, an illegal character (not conforming to EIA or ISO) is detected.
0013	In tape mode operation, one block capacity (128 characters) has been exceeded.
0014	In tape mode operation, there is no response of data set ready signal.
0015	In tape mode operation, overflow has occurred with the input numerical value (more than 9 characters).
0016	RS-232C interface transfer error has occurred.
0017	RS-232C interface overrun has occurred. (protocol setting error or transfer error)
0018	There is an error in the RS-232C interface line.
0019	Framing error has occurred (stop bit setting error or transmission error).
0020	The designated line has already been opened.
0021	The designated line has not been opened.
0022	Double-call or combination is incorrect.
0023	Data has not been sent within the specified length of time.
0024	Send or receive start processing has not been executed.
0025	There is an error in the setting of parameters.
0050	The parameter which is made valid after power off/on operation has been set.
0051	The parameter which is made valid only when the program area is cleared has been set.
0060	There is an error in the designation of category data in external data input.
0061	There is an error in the designation of data in external data input.
0062	The program designated by the external data number search is not found.
0065	The setting for external tool offset multiplication ratio is "11" or greater.
0066	The error input has been turned ON in external tool offset.
0100	Overflow has occurred with one-block buffer (128 characters).
0101	There is no data specified following an address, or the data is specified without address.
0102	"-" or "." is not used correctly.
0103	Illegal character is specified in the significant information area.
0104	Overflow has occurred with the input numerical value (more than 9 characters).
0105	An axis not defined as an axis is designated.
0106	The same address is designated more than one time in one block.

A3

Appendix Table 3.2 Alarm Table (cont'd)

Alarm No.	Description
0107	Nesting of “(” ; “)” is used without “(” ; “(” and “)” are not used in pairs.
0108	Addresses having the same function are designated more than one time in one block.
0110	More than one M code is designated in one block although multiple M code option is not selected.
0111	The number of digits in the specified M code is larger than the allowable limit.
0113	There is an error in the designation of an internal M code.
0116	M93 is designated although designation is not allowed.
0125	M or T is designated although designation of M or T is not allowed.
0126	There is no M02/M30 command in memory mode or tape mode operation.
0127	<ul style="list-style-type: none"> • In the mirror image mode, an illegal G is designated. • Mirror image is turned ON in the mirror image prohibited mode.
0130	More than one S code is designated in one block although multiple S control option is not selected.
0131	The number of digits in the specified S code is larger than the allowable limit.
0132	An S code is specified independently.
0140	The number of digits in the specified T code is larger than the allowable limit.
0141	In the tool selection command, tool number is “0”.
0143	The ATC command is not designated independently, or there is an error in the ATC command format.
0147	A tool number other than the designated number is designated.
0150	Tool position offset number is too large.
0153	The G code of 01 group designated in the offset command block is other than G00/G01.
0154	Designation of address in offset designation is incorrect.
0158	There is an error in the designation of an offset number. (offset other than the selected system, designation in synchronized feed control, etc.)
0160	An illegal G code is designated. Or a G code for which the corresponding option is not selected is designated.
0161	G codes which cannot be used in combination in one block are designated.
0162	An address which is mandatory is not specified.
0163	Designation of address in notch signal designation is incorrect.
0170	An illegal G code is designated in a canned cycle.
0172	R-point level return is designated in G77 (back boring) canned cycle.
0173	The G of 01 group valid immediately before the entry to a hole-machining canned cycle is other than G01.
0174	In G73/G83, Q and I are not designated. G73/G83 is designated with Q = I = 0.

A3

Appendix Table 3.2 Alarm Table (cont'd)

Alarm No.	Description
0175	In G70 - G72, designation of address is incorrect.
0176	There is no hole-bottom command in the designation of a hole-machining canned cycle.
0180	At the start-up of tool radius offset or nose R offset mode, <ul style="list-style-type: none"> • There are no axis move commands within 3 blocks. • M00, M01, M02, or M30 is designated. • Circular interpolation mode is designated.
0181	The tool radius offset or nose R offset mode ends in the circular interpolation mode.
0182	An illegal G code is designated in the tool radius offset or nose R offset mode.
0183	In the tool radius offset or nose R offset mode, offset plane has been changed. Circular arc is designated outside the offset plane.
0184	In the tool radius offset or nose R offset mode, point of intersection cannot be obtained.
0185	In the tool radius offset or nose R offset mode, the shape causing reversed tool movement is designated.
0186	In the tool radius offset or nose R offset mode, a system variable for which buffering is not allowed is designated.
0187	In the tool radius offset or nose R offset mode, interference is detected.
0188	In the tool radius offset or nose R offset mode, automatic interference correction is not possible.
0189	Offset mode error (work area has been destroyed, or no output data in data output operation)
0190	In circular interpolation commands, a circle of "0" radius has been specified.
0191	In circular interpolation, commands including three axes are designated. In helical interpolation, axes exceeding the number of controllable axes are designated.
0192	The plane cannot be defined from the given circular interpolation commands. In circular interpolation, commands of four or more axes are designated.
0193	The center cannot be obtained from the designated R.
0199	In the nose R or tool radius offset mode, axis movement commands to cancel the offset mode such as a canned cycle command while the mode is temporarily canceled by M00 or other command.
0200	In inputting an offset amount by using a program, a number designated with P is larger than the allowable limit.
0201	In inputting an offset amount by using a program, offset amount is too large. There is an error in the format.
0202	In "G10 Q2" (inputting workpiece coordinate system shift amount by program), a number designated with P is larger than the allowable limit.
0203	When changing the cutting monitoring level, all of necessary addresses are not designated or a value outside the allowable range is designated.
0204	An attempt was made to write a command using G10 although writing is not permitted.
0209	There is an error in the G301 command format.
0210	In user macro, the value of constant is outside the allowable range.

A3

Appendix Table 3.2 Alarm Table (cont'd)

Alarm No.	Description
0211	The number of cancel codes for G67 is too many.
0212	There is an error in the format.
0213	A value not defined as a variable number is used.
0214	A variable used in replace statement is the variable which cannot be used for this operation.
0215	The nesting level of “[]” exceeds the allowable limit.
0216	The nesting level of macroprogram call exceeds the allowable limit.
0217	DO - END is not used in pairs.
0218	The numbers of brackets “[” and “]” do not agree with each other.
0219	In “DO M”, $1 \leq m \leq 3$ is not satisfied.
0220	In “GOTO n”, “n” is outside the allowable range or “n” is not found.
0221	In a macroprogram, division by “0” is executed.
0222	Square root of a negative value
0223	Floating point data exceeds the allowable range.
0224	In modal call (G66), axis command is specified with M99 return designation.
0225	Overflow has occurred with operation stack.
0226	Execution of the following functions was impossible: ASIN, ACOS, LN, SQRT
0227	Overflow has occurred during conversion into integer.
0228	Overflow has occurred with the input data for the BCD function.
0229	There is an error in the format of the BIN function.
0230	Overflow has occurred as the result of execution of the EXP function.
0240	Reference point return has not been completed with the axis for which G29, G30 is designated.
0241	Reference point return is invalid for the axis for which G28 is designated.
0242	The G28 automatic coordinate system setting is invalid for a linear axis.
0250	An illegal code has been designated in a solid tap program.
0255	A C command is designated for the spindle in the spindle control mode.
0256	An S command is designated for the spindle in the C-axis control mode.
0260	<ul style="list-style-type: none"> • There is no P or Q command in the M98 block. • There is no P command in the G65/G66 block.
0261	Nesting level of M98 subprogram call exceeds the allowable limit.

Appendix Table 3.2 Alarm Table (cont'd)

Alarm No.	Description
0262	In a program that calls a macroprogram by G, M, or T code (M98, M99, G65, G66), the designated program number or sequence number is not found.
0263	An attempt was made to start a program by executing address search after buffering subprogram or macro call.
0281	There is an error in address word designation format in the G111 command block.
0282	Angle designation made by A and B in the G111 block is outside the allowable range of $-350^\circ \leq A, B \leq 360^\circ$
0283	The first chamfering area is <ul style="list-style-type: none"> • Outside the rectangle defined by the start and end points. • Outside the range between the 45° line from the start point toward the end point and the line from the end point toward the start point.
0284	The shape defined by the G111 block is erroneous.
0285	M, S, and/or T is designated in the G111/G112 block.
0286	There is an error in address word designation format in the G112 command block.
0287	The shape defined by the G112 block is erroneous.
0290	A sequence number is not found at the restart of the program.
0291	The operation that changes the coordinate system is executed at the restart of the program. (G50/G92, tool setting up, or ORG operation has been executed in the MDI mode.)
0292	At the restart of the program, an axis was moved by MDI intervention.
0300	In tool registration using G112 macro, T9999 is registered.
0301	There are no tools registered in the designated tool group.
0302	All tools in the designated tool group are in the skipped status.
0305	The tool life control data is not stored in the tool file.
0315	The coordinate system setting command is designated in the tool setup mode.
0370	There is no F/E command in a cutting program.
0371	An E command is designated in the mm/min mode.
0372	An F/E command value is too large.
0380	An axis command is designated in the G04, G40, G21 block.
0381	An axis command is designated in the G10, G22, G23 block.
0382	More than one area has been selected from No. 3 - No. 5 prohibited areas.
0390	An execution program does not exist.
0391	An execution program is being input.
0392	An execution program is being edited.

A3

Appendix Table 3.2 Alarm Table (cont'd)

Alarm No.	Description
0393	A sequence number that does not exist is designated in M98 Q G25 commands.
0395	Cycle start is executed after changing the mode from tape to memory, or from memory to tape.
0397	During tape/direct operation, operation interruption that does not allow the re-execution has been carried out.
0400	An O number of six or more digits is designated.
0401	An N number of six or more digits is designated.
0402	A P number of six or more digits is designated.
0406	Before the axis move, the axis is in the stored stroke limit No. 2 area.
0407	Before the axis move, the axis is in the stored stroke limit No. 3 area.
0408	Before the axis move, the axis is in the stored stroke limit No. 4 area.
0409	Before the axis move, the axis is in the stored stroke limit No. 5 area.
0411	Reference point return has not been completed (1st-axis).
0412	Reference point return has not been completed (2nd-axis).
0413	Reference point return has not been completed (3rd-axis).
0414	Reference point return has not been completed (4th-axis).
0415	Reference point return has not been completed (5th-axis).
0421	After the execution of G27, the axis has not returned to the reference point (1st-axis).
0422	After the execution of G27, the axis has not returned to the reference point (2nd-axis).
0423	After the execution of G27, the axis has not returned to the reference point (3rd-axis).
0424	After the execution of G27, the axis has not returned to the reference point (4th-axis).
0425	After the execution of G27, the axis has not returned to the reference point (5th-axis).
0431	Before the axis move, the axis has reached the entry prohibited area (outside) of stored stroke limit (1st-axis)
0432	Before the axis move, the axis has reached the entry prohibited area (outside) of stored stroke limit (2nd-axis)
0433	Before the axis move, the axis has reached the entry prohibited area (outside) of stored stroke limit (3rd-axis)
0434	Before the axis move, the axis has reached the entry prohibited area (outside) of stored stroke limit (4th-axis)
0435	Before the axis move, the axis has reached the entry prohibited area (outside) of stored stroke limit (5th-axis)
0440	There is a discrepancy in angle designation in the G01 linear interpolation operation (angle designation).
0445	There is an error in I, K, and R designation in chamfering or rounding, or the value set for I, K, and R is too large.
0446	In chamfering or rounding, the commands in the designated block constitute a taper.

Appendix Table 3.2 Alarm Table (cont'd)

Alarm No.	Description
0450	The lead variation amount in the G34 thread cutting operation is greater than the allowable maximum value, or a value that causes the lead to have a negative value is designated.
0451	Chamfering or rounding is designated in a thread cutting block.
0452	Thread cutting block is designated in the mm/min mode.
0453	The value set for B in multiple-thread cutting commands is outside the allowable range.
0454	In thread cutting with thread chamfering, the chamfering amount in the direction of the chamfering axis is smaller than the value set for a parameter, or chamfering amount is "0" in the G92 mode operation.
0455	Cutting time used for executing commands in one block is too short in continuous thread cutting operation.
0460	In the G90, G92, and G94 blocks, an address that must not be designated is designated.
0461	There is no P or Q command in the G70 - G73 blocks.
0462	The sequence number designated by P or Q command in the G70 - G73 blocks cannot be found.
0463	The number of blocks defining the finishing shape which are designated by P or Q command in the G70 - G73 blocks is too many.
0464	The finishing shape commands for the G70 - G73 cycles include G and/or M codes that must not be designated.
0465	The mode of last movement designated in the definition of finishing shape for G70 - G73 cycle is chamfering or rounding.
0466	There is an error in the finish shape for G70/G71 cycle.
0467	The value set for D in the G73 block is "0", or "128" or greater. Or both I and K in the G73 block are "0".
0468	The value set for D and K in the G76 block is outside the allowable range.
0469	In rough turning cycle of G71, G72 R1 command, four or more operation interrupted points are included in the finishing shape program.
0470	In the tape mode operation, the information of the block designated by P or Q in the G70 block is not stored in the internal memory.
0471	In the G70 - G76 block, an address that must not be designated is used or all necessary addresses are not designated.
0472	There is an error in the shape for G70/G71 cycle.
0480	There is an error in the cylindrical interpolation commands.
0481	In the cylindrical interpolation mode, a command that cannot be executed is designated.
0482	There is an error in the polar coordinate interpolation commands.
0483	In the polar coordinate interpolation, a command that cannot be executed is designated.
0491	In the G31 block, skip signal (1) has not been input.
0494	When G31 is executed, the skip signal (1) is not ready.

A3

A3

Appendix Table 3.2 Alarm Table (cont'd)

Alarm No.	Description
0497	Conditions for executing skip have not been satisfied until the completion of the G311 block.
1000	DNC time-out error has occurred.
1001	DNC DR line error has occurred.
1002	DNC packet length error has occurred.
1003	DNC 8251 error has occurred.
1004	DNC check sum error has occurred.
1005	DNC command error has occurred.
1006	DNC high-speed cutting mode error has occurred.
1009	An attempt was made to execute DNC operation although the corresponding option is not available.
1011	The dimension unit system (mm, inch) has been changed. Turn OFF the power once.
1080	Execution of a program block has been stopped with the ERR 0 signal ON.
1090	Setting area total check error has occurred.
1091	Parameter area total check error has occurred.
1092	Battery backed-up memory area total check error has occurred.
1093	Offset and work coordinate system shift amount area total check error has occurred.
1094	Macro variable area total check error has occurred.
1095	Machining program area total check error has occurred.
1096	Tool life control data area total check error has occurred.
1098	The fan is faulty.
1099	High temperature in the NC unit.
2001	Overtravel has occurred (1st-axis).
2002	Overtravel has occurred (2nd-axis).
2003	Overtravel has occurred (3rd-axis).
2004	Overtravel has occurred (4th-axis).
2005	Overtravel has occurred (5th-axis).
2011	Axis has reached the stored stroke limit No. 1 area (1st-axis).
2012	Axis has reached the stored stroke limit No. 1 area (2nd-axis).
2013	Axis has reached the stored stroke limit No. 1 area (3rd-axis).
2014	Axis has reached the stored stroke limit No. 1 area (4th-axis).

Appendix Table 3.2 Alarm Table (cont'd)

Alarm No.	Description
2015	Axis has reached the stored stroke limit No. 1 area (5th-axis).
2021	Axis has reached the outside of the stored stroke limit No. 2 area (1st-axis).
2022	Axis has reached the outside of the stored stroke limit No. 2 area (2nd-axis).
2023	Axis has reached the outside of the stored stroke limit No. 2 area (3rd-axis).
2024	Axis has reached the outside of the stored stroke limit No. 3 area (1st-axis).
2025	Axis has reached the outside of the stored stroke limit No. 3 area (2nd-axis).
2026	Axis has reached the outside of the stored stroke limit No. 3 area (3rd-axis).
2027	Axis has reached the outside of the stored stroke limit No. 4 area (1st-axis).
2028	Axis has reached the outside of the stored stroke limit No. 4 area (2nd-axis).
2029	Axis has reached the outside of the stored stroke limit No. 4 area (3rd-axis).
2031	Axis has reached the outside of the stored stroke limit No. 5 area (1st-axis).
2032	Axis has reached the outside of the stored stroke limit No. 5 area (2nd-axis).
2033	Axis has reached the outside of the stored stroke limit No. 5 area (3rd-axis).
2040	Axis has reached the inside of the stored stroke limit No. 2 area.
2041	Axis has reached the inside of the stored stroke limit No. 3 area.
2042	Axis has reached the inside of the stored stroke limit No. 4 area.
2043	Axis has reached the inside of the stored stroke limit No. 5 area.
2061	Reference point return area error has occurred (1st-axis).
2062	Reference point return area error has occurred (2nd-axis).
2063	Reference point return area error has occurred (3rd-axis).
2064	Reference point return area error has occurred (4th-axis).
2065	Reference point return area error has occurred (5th-axis).
2071	Reference point return position error has occurred (1st-axis).
2072	Reference point return position error has occurred (2nd-axis).
2073	Reference point return position error has occurred (3rd-axis).
2074	Reference point return position error has occurred (4th-axis).
2075	Reference point return position error has occurred (5th-axis).
2081	In reference point return, the deceleration LS is turned OFF after it has been turned ON once and then turned ON again (1st-axis).

A3

A3

Appendix Table 3.2 Alarm Table (cont'd)

Alarm No.	Description
2082	In reference point return, the deceleration LS is turned OFF after it has been turned ON once and then turned ON again (2nd-axis).
2083	In reference point return, the deceleration LS is turned OFF after it has been turned ON once and then turned ON again (3rd-axis).
2084	In reference point return, the deceleration LS is turned OFF after it has been turned ON once and then turned ON again (4th-axis).
2085	In reference point return, the deceleration LS is turned OFF after it has been turned ON once and then turned ON again (5th-axis).
2091	According to the parameter setting, retraction operation must be made in reference point return operation (1st-axis).
2092	According to the parameter setting, retraction operation must be made in reference point return operation (2nd-axis).
2093	According to the parameter setting, retraction operation must be made in reference point return operation (3rd-axis).
2094	According to the parameter setting, retraction operation must be made in reference point return operation (4th-axis).
2095	According to the parameter setting, retraction operation must be made in reference point return operation (5th-axis).
2101	P-SET error has occurred (1st-axis).
2102	P-SET error has occurred (2nd-axis).
2103	P-SET error has occurred (3rd-axis).
2104	P-SET error has occurred (4th-axis).
2105	P-SET error has occurred (5th-axis).
2111	Absolute position overflow has occurred with the absolute position detection function (1st-axis).
2112	Absolute position overflow has occurred with the absolute position detection function (2nd-axis).
2113	Absolute position overflow has occurred with the absolute position detection function (3rd-axis).
2114	Absolute position overflow has occurred with the absolute position detection function (4th-axis).
2115	Absolute position overflow has occurred with the absolute position detection function (5th-axis).
2121	There is no battery mounted on the AXIS board (1st-axis).
2122	There is no battery mounted on the AXIS board (2nd-axis).
2123	There is no battery mounted on the AXIS board (3rd-axis).

Appendix Table 3.2 Alarm Table (cont'd)

Alarm No.	Description
2124	There is no battery mounted on the AXIS board (4th-axis).
2125	There is no battery mounted on the AXIS board (5th-axis).
2131	Difference in axis positions between the position at the previous power off and the position at the start-up of the absolute position detection function is excessively large (1st-axis).
2132	Difference in axis positions between the position at the previous power off and the position at the start-up of the absolute position detection function is excessively large (2nd-axis).
2133	<i>Difference in axis positions between the position at the previous power off and the position at the start-up of the absolute position detection function is excessively large (3rd-axis).</i>
2134	<i>Difference in axis positions between the position at the previous power off and the position at the start-up of the absolute position detection function is excessively large (4th-axis).</i>
3000	Servo power is not turned on.
3001	The control is not ready.
3002	NC has entered the emergency stop state.
3010	The memory used to store machining programs has not been initialized.
3011	In initialization processing, expansion memory for storing machining programs and the memory after power on do not match.
3012	Axis configuration setting parameters do not agree with the physical axis configuration, or the specified option is not available.
3013	YENET station number parameter setting error has occurred.
3021	Fuse is blown (1st-axis).
3022	Fuse is blown (2nd-axis).
3023	Fuse is blown (3rd-axis).
3024	Fuse is blown (4th-axis).
3025	Fuse is blown (5th-axis).
3041	Excessively large deviation error (1st-axis)
3042	Excessively large deviation error (2nd-axis)
3043	Excessively large deviation error (3rd-axis)
3044	Excessively large deviation error (4th-axis)
3045	Excessively large deviation error (5th-axis)
3051	Excessively large deviation error (No. 1 spindle)
3052	Excessively large deviation error (No. 2 spindle)
3060	Overload (other than servo axis)

A3

A3

Appendix Table 3.2 Alarm Table (cont'd)

Alarm No.	Description
3061	Overload (1st-axis)
3062	Overload (2nd-axis)
3063	Overload (3rd-axis)
3064	Overload (4th-axis)
3065	Overload (5th-axis)
3071	Collision of the axis has been detected (1st-axis).
3072	Collision of the axis has been detected (2nd-axis).
3073	Collision of the axis has been detected (3rd-axis).
3074	Collision of the axis has been detected (4th-axis).
3075	Collision of the axis has been detected (5th-axis).
3081	Disconnection in PG wiring (1st-axis)
3082	Disconnection in PG wiring (2nd-axis)
3083	Disconnection in PG wiring (3rd-axis)
3084	Disconnection in PG wiring (4th-axis)
3085	Disconnection in PG wiring (5th-axis)
3091	Disconnection in PG wiring (No. 1 spindle)
3092	Disconnection in PG wiring (No. 2 spindle)
3100	YENET1200 drive error has occurred.
3101	Servopack error has occurred (1st-axis).
3102	Servopack error has occurred (2nd-axis).
3103	Servopack error has occurred (3rd-axis).
3104	Servopack error has occurred (4th-axis).
3105	Servopack error has occurred (5th-axis).
3111	Servopack communication error has occurred (1st-axis).
3112	Servopack communication error has occurred (2nd-axis).
3113	Servopack communication error has occurred (3rd-axis).
3114	Servopack communication error has occurred (4th-axis).
3115	Servopack communication error has occurred (5th-axis).
3121	Over-speed has been detected (1st-axis).

Appendix Table 3.2 Alarm Table (cont'd)

Alarm No.	Description
3122	Over-speed has been detected (2nd-axis).
3123	Over-speed has been detected (3rd-axis).
3124	Over-speed has been detected (4th-axis).
3125	Over-speed has been detected (5th-axis).
3131	Serial communication error has occurred in the communication with the inverter (No. 1 spindle).
3132	Serial communication error has occurred in the communication with the inverter (No. 2 spindle).
3141	Overrun is detected with the servo controlled axis (1st-axis).
3142	Overrun is detected with the servo controlled axis (2nd-axis).
3143	Overrun is detected with the servo controlled axis (3rd-axis).
3144	Overrun is detected with the servo controlled axis (4th-axis).
3145	Overrun is detected with the servo controlled axis (5th-axis).
3151	Phase detection error has occurred (1st-axis)
3152	Phase detection error has occurred (2nd-axis)
3153	Phase detection error has occurred (3rd-axis)
3154	Phase detection error has occurred (4th-axis)
3155	Phase detection error has occurred (5th-axis)
3161	Malfunctioning is detected with the absolute encoder (1st-axis).
3162	Malfunctioning is detected with the absolute encoder (2nd-axis).
3163	Malfunctioning is detected with the absolute encoder (3rd-axis).
3164	Malfunctioning is detected with the absolute encoder (4th-axis).
3165	Malfunctioning is detected with the absolute encoder (5th-axis).
3181	Malfunctioning is detected with the PG counter of the absolute encoder (1st-axis).
3182	Malfunctioning is detected with the PG counter of the absolute encoder (2nd-axis).
3183	Malfunctioning is detected with the PG counter of the absolute encoder (3rd-axis).
3184	Malfunctioning is detected with the PG counter of the absolute encoder (4th-axis).
3185	Malfunctioning is detected with the PG counter of the absolute encoder (5th-axis).
3191	An error has occurred in the reduction of fraction processing for gear ratio (1st-axis).
3192	An error has occurred in the reduction of fraction processing for gear ratio (2nd-axis).
3193	An error has occurred in the reduction of fraction processing for gear ratio (3rd-axis).

A3

A3

Appendix Table 3.2 Alarm Table (cont'd)

Alarm No.	Description
3194	An error has occurred in the reduction of fraction processing for gear ratio (4th-axis).
3195	An error has occurred in the reduction of fraction processing for gear ratio (5th-axis).
3221	Disconnection in wiring to the separately installed PG (1st-axis)
3222	Disconnection in wiring to the separately installed PG (2nd-axis)
3223	Disconnection in wiring to the separately installed PG (3rd-axis)
3224	Disconnection in wiring to the separately installed PG (4th-axis)
3225	Disconnection in wiring to the separately installed PG (5th-axis)
3240	Servo has been turned off due to turning ON of the ERR 2 signal.
3241	Absolute error (separately installed PG) has occurred (1st-axis).
3242	Absolute error (separately installed PG) has occurred (2nd-axis).
3243	Absolute error (separately installed PG) has occurred (3rd-axis).
3244	Absolute error (separately installed PG) has occurred (4th-axis).
3245	Absolute error (separately installed PG) has occurred (5th-axis).
3250	NMI interruption has occurred when turning the power OFF.
3251	NMI interruption has occurred due to loss of power.
3252	NMI interruption has occurred due to the occurrence of bus gate error.
3253	NMI interruption has occurred due to the occurrence of watchdog time-out.
3260	SH-INTEX synchronization error has occurred.
3261	SH-MOTION synchronization error has occurred.
3262	INTEX-MOTION synchronization error has occurred.
3263	MOTION-PLC synchronization error has occurred.
3264	MOTION-AXIS synchronization error has occurred.
3265	ACGC synchronization error has occurred.
3266	DNC synchronization error has occurred.
3270	Data error has occurred when turning the power OFF (battery backed-up memory).
3271	Data error has occurred when turning the power OFF (tool life control).
3272	Data error has occurred when turning the power OFF (macro).
3273	Data error has occurred when turning the power OFF (internal memory).
3274	Program has been destroyed due to turning the power off during editing (program).

Appendix Table 3.2 Alarm Table (cont'd)

Alarm No.	Description
3275	Data error has occurred when turning the power OFF during editing (custom variables).
3276	The power has been turned OFF during editing. This requires the program to be checked after turning the power ON.
3281	Time-out of the YENET1200 command (1st-axis)
3282	Time-out of the YENET1200 command (2nd-axis)
3283	Time-out of the YENET1200 command (3rd-axis)
3284	Time-out of the YENET1200 command (4th-axis)
3285	Time-out of the YENET1200 command (5th-axis)
3291	Time-out of the YENET1200 command (No. 1 spindle)
3292	Time-out of the YENET1200 command (No. 2 spindle)
3299	Communication error has occurred in YENET1200 (I/O).
3301	Excessively large current is supplied to the Servopack main circuit (1st-axis).
3302	Excessively large current is supplied to the Servopack main circuit (2nd-axis).
3303	Excessively large current is supplied to the Servopack main circuit (3rd-axis).
3304	Excessively large current is supplied to the Servopack main circuit (4th-axis).
3305	Excessively large current is supplied to the Servopack main circuit (5th-axis).
3331	DC voltage in the Servopack main circuit is abnormally high (1st-axis).
3332	DC voltage in the Servopack main circuit is abnormally high (2nd-axis).
3333	DC voltage in the Servopack main circuit is abnormally high (3rd-axis).
3334	DC voltage in the Servopack main circuit is abnormally high (4th-axis).
3335	DC voltage in the Servopack main circuit is abnormally high (5th-axis).
3351	Heat sink in the Servopack has been overheated (1st-axis).
3352	Heat sink in the Servopack has been overheated (2nd-axis).
3353	Heat sink in the Servopack has been overheated (3rd-axis).
3354	Heat sink in the Servopack has been overheated (4th-axis).
3355	Heat sink in the Servopack has been overheated (5th-axis).
3381	YENET1200 communication error (1st-axis)
3382	YENET1200 communication error (2nd-axis)
3383	YENET1200 communication error (3rd-axis)
3384	YENET1200 communication error (4th-axis)

A3

A3

Appendix Table 3.2 Alarm Table (cont'd)

Alarm No.	Description
3385	YENET1200 communication error (5th-axis)
3391	YENET1200 communication error (No. 1 spindle)
3392	YENET1200 communication error (No. 2 spindle)
3395	Converter error
3401	Converter error (1st-axis)
3402	Converter error (2nd-axis)
3403	Converter error (3rd-axis)
3404	Converter error (4th-axis)
3405	Converter error (5th-axis)
3411	Servo unit error (1st-axis)
3412	Servo unit error (2nd-axis)
3413	Servo unit error (3rd-axis)
3414	Servo unit error (4th-axis)
3415	Servo unit error (5th-axis)
3421	Inverter unit error
3425	YENET 1200 watchdog error (No. 1 spindle)
3426	YENET 1200 watchdog error (No. 2 spindle)
3431	YENET 1200 watchdog error (1st-axis)
3432	YENET 1200 watchdog error (2nd-axis)
3433	YENET 1200 watchdog error (3rd-axis)
3434	YENET 1200 watchdog error (4th-axis)
3435	YENET 1200 watchdog error (5th-axis)
3441	Grounding fault (1st-axis)
3442	Grounding fault (2nd-axis)
3443	Grounding fault (3rd-axis)
3444	Grounding fault (4th-axis)
3445	Grounding fault (5th-axis)
3451	Follow-up error (1st-axis)
3452	Follow-up error (2nd-axis)

Appendix Table 3.2 Alarm Table (cont'd)

Alarm No.	Description
3453	Follow-up error (3rd-axis)
3454	Follow-up error (4th-axis)
3455	Follow-up error (5th-axis)
3461	There is an error in motor code setting (1st-axis)
3462	There is an error in motor code setting (2nd-axis)
3463	There is an error in motor code setting (3rd-axis)
3464	There is an error in motor code setting (4th-axis)
3465	There is an error in motor code setting (5th-axis)
8001	RAM check error has occurred.
9010	TH parity has occurred.
9011	TV parity has occurred.
9012	In RS-232C communications, an illegal character (not conforming to EIA or ISO) is detected.
9013	In RS-232C communications, one block capacity (128 characters) has been exceeded.
9014	In RS-232C communications, there is no response of data set ready signal.
9015	Overflow has occurred with the input numerical value (more than 9 characters).
9016	In RS-232C communications, interface parity error has occurred.
9017	In RS-232C communications, interface overrun has occurred.(protocol setting error or transmission error)
9018	There is an error in RS-232C interface line selection.
9019	Framing error has occurred (stop bit setting error or transmission error).
9020	The designated line has already been opened.
9021	The designated line has not been opened.
9022	Double-call or combination is incorrect.
9023	Data has not been sent within the specified length of time.
9024	Send or receive processing is not executed.
9025	There is an error in the designated parameter.

A3

APPENDIX 4

INDEX

In Appendix 4, technical terms specific to NC and J300L are arranged in alphabetical order.

Please use this index when looking for descriptions using the technical term as the key code.

A4

A

- Absolute Error 9 - 19
- Absolute Position Error 9 - 19
- Action Keys 3 - 13
- Address Keys 3 - 12
- Address Search 6 - 6
- ALARM DISPLAY JOB 7 - 10
- Alarm Function 7 - 10
- Alarm Table A3 - 3
- Alarms Not Indicated by Alarm Numbers 9 - 23
- Arrangement of Battery and Indicator Lamp (LED) 2 - 13
- Automatic Handle Mode Offset 2 - 37
- AUTOMATIC OPERATION 2 - 24, 2 - 31
- AUTOMATIC OPERATIONS 2 - 40
- AUX Key 3 - 14
- Auxiliary Function Lock 2 - 33
- Axis Variable Data A1 - 20

B

- Background Reset Function 8 - 14
- BG Reset 4 - 60
- Broken PG Cable 9 - 18
- Buzzer Function 3 - 22

C

- Calendar Function 7 - 14
- Calling a Part Program 4 - 4, 4 - 33
- Cause of Alarm and Corrective Action 9 - 6
- Checking the Motors for Abnormalities 2 - 10
- Checking the NC Information 9 - 3
- Checking the Status of Troubles 9 - 2
- CLASSIFICATION OF ALARMS A3 - 2
- CLASSIFICATION OF THE PARAMETERS A2 - 2
- Clearing the Offset Data 5 - 4
- Clearing the Workpiece Coordinate System Shift Amount 5 - 6
- CNC Part Program Execution Control A1 - 4
- Collective Display of Command Values 6 - 14
- Collective Display of Present Position Data 7 - 2
- COMMAND VALUE DISPLAY JOB 6 - 14
- Control Not-Ready 9 - 16
- Converter Alarm 9 - 21
- coordinate system for machining 2 - 24
- Copying a Part Program 4 - 39
- CRT 3 - 9
- Cursor Keys 3 - 13

D

- Data Keys 3 - 12
- Deleting a Part Program 4 - 23, 4 - 35
- Deleting an MDI Program 6 - 13
- Display of Alarm Information 9 - 5

- Display of Present Position Data in the
External Coordinate Values 7 - 5
- Display of Present Position Data in the
Workpiece Coordinate System 7 - 4
- Display of Remaining Distance 7 - 6
- Display of Subprogram Nesting Information 6 - 10
- Display of the Directory of Part Programs 4 - 26
- Displaying the ON/OFF Status of the I/O Signals 8 - 8
- Displaying the ON/OFF Status of the Selected I/O Signals 8 - 9
- Displaying the Tool Life Control Data 5 - 7
- Dry Run 2 - 32

E

- Editing a Part Program 4 - 7
- Editing an MDI Program 6 - 11
- Editing the Part Program Stored in Memory 6 - 7
- 8-inch Take-up Reel 2 - 7
- Entry of an MDI Program 6 - 11
- Erasing the Tool Life Control Data 5 - 10
- Error Pulse Display Function 7 - 9
- Excessive Follow-up Error 9 - 17
- Excessive Speed 9 - 18
- Execution of a Part Program 6 - 9
- Execution of an MDI Program 6 - 12

F

- Feed Hold 2 - 28
- Feed Hold in Thread Cutting 2 - 34
- Feedrate Override 2 - 29, 9 - 33
- Follow-up Error 9 - 22
- Function Structure 3 - 4
- Functions 3 - 3
- Fuse Blown 9 - 17

G

- GENERAL FLOW OF OPERATION 2 - 3
- Ground Fault 9 - 21

H

- Handle Feed 2 - 17
- Heat Sink Overheat 9 - 20
- High Temperature 9 - 13
- high-speed reference point return 2 - 18, 2 - 21

I

- I/O Device Setting Function 8 - 14
- I/O MONITORING JOB 8 - 8
- INPUT SIGNALS (PLC → NC) A1 - 2
- Input/output and Verify Function 8 - 12
- INPUT/OUTPUT AND VERIFY JOB 8 - 12

Inputting a Part Program	4 - 40
Inspection of the Battery	2 - 12
Inspection of the NC Unit	2 - 6
Inspection of the Tape Reader	2 - 7
INTERNAL INFORMATION JOB	8 - 15
Internal Switch Function	6 - 15
Inverter Alarm	9 - 19
Inverter Unit Alarm	9 - 21

J

Jobs	3 - 3
Jog Feed	2 - 16
Jog Feedrate	9 - 27

K

Key Memory Function	8 - 16
---------------------------	--------

M

Machine Lock	2 - 33
Macro Variable Function	6 - 17
MAINTENANCE DATA	9 - 2
Manual Absolute	2 - 38
MANUAL OPERATION	2 - 15, 2 - 18
Manual Operation Intervention during Automatic Operation	2 - 35
Manual Rapid Traverse	2 - 15
Manual Reference Point Return	2 - 19
Manual Reference Point Return to the Second Reference Point	2 - 22
MDI Operation	2 - 27
MDI Operation Intervention during Automatic Operation	2 - 36
MDI OPERATION JOB	6 - 11
Memory Dump Function	8 - 16
Memory Operation	2 - 26

N

NC OPERATION PANEL	3 - 8
NC Part Program Execution Control	A1 - 12
NC System Software	9 - 4
9-inch Graphic Display	3 - 9
No. 2 Spindle Control	A1 - 8, A1 - 18
Normal Display on CRT Screen	3 - 15
number of actually used characters	4 - 27
numerical setting up	7 - 9

O

1-line MDI	2 - 23
Operating Time Function	7 - 15
OPERATION INTERVENTION DURING AUTOMATIC OPERATION	2 - 35
Operation Mode Control Signals	A1 - 2, A1 - 10
OPERATION STEPS	3 - 2
Optional Block Skip	2 - 31

optional block skip B function	2 - 32
Optional Stop	2 - 31
OUTPUT SIGNALS (NC PLC)	A1 - 10
Outputting a Part Program	4 - 44
Over Current	9 - 20
Over Voltage	9 - 20
Overload	9 - 17
Override	2 - 29
Overrun Prevention	9 - 18

P

P-SET Error	9 - 15
Page Keys	3 - 12
Parameter Function	8 - 3
PARAMETER JOB	8 - 3
Parameter Table	A2 - 3
Parity Error	9 - 7
PART PROGRAM DIRECTORY JOB	4 - 26
PART PROGRAM EDIT JOB	4 - 3
PART PROGRAM INPUT/OUTPUT AND VERIFY JOB	4 - 40
Phase Detection Error	9 - 19
Pitch Error Function	8 - 7
Pop-up Menu	3 - 20
POWER ON/OFF Buttons	3 - 8
Preparation before Turning the Power ON	2 - 8
Preparation of Automatic Operation	2 - 24
PRESENT POSITION DATA CONTROL JOB	7 - 2
Procedure for Turning the Power OFF	2 - 11
Procedure for Turning the Power ON	2 - 9
Process Keys	3 - 10
Process Screens	3 - 3
Program Information Displayed on Screen	6 - 3
PROGRAM JOB	6 - 3
Program Number Search	6 - 4
Program Restart	2 - 43

R

RAPID	2 - 15
Rapid Traverse Override	2 - 30
Reference Point	2 - 19
Reference Point Return Area Error	9 - 14
Reference Point Return Position Error	9 - 14
Renaming a Part Program	4 - 37
RESET Key	3 - 14
Return to the Operation Interrupted Point	2 - 40
Return to the Setup Point	2 - 40
RS-232C Communications Parameters	4 - 55
RS-232C Error	9 - 8
RS-232C Interface Troubleshooting Flowchart	9 - 8

S

Saving a Part Program after Editing	4 - 22
Saving the Present Position Data	2 - 42

A4

sequence number search	6 - 7
Sequence Parameter Function	8 - 7
Serial Interface Setting	4 - 56, 9 - 10
Servo Alarm	9 - 18
Servo Alarm Function	7 - 11
Servo Axis Control	A1 - 5, A1 - 14
Servo Axis Control Signals	A1 - 5
Servo Communication Alarm	9 - 18
Servo Power Not Ready	9 - 15
Servo Unit Alarm	9 - 21
Setting Function	6 - 19, 8 - 6
SETTING JOB	6 - 15
Setting the Communication Conditions	4 - 55
Setting the Coordinate Systems	7 - 7
Setting the Tool Life Control Data	5 - 8
SETUP JOB	5 - 2
Soft-keys	3 - 11
Software Switch Function	6 - 16
Spindle Control	A1 - 7, A1 - 17
Step Feed	2 - 16
Storing an MDI Program	6 - 13

A4

T

Tape Reader	9 - 38
TIME CONTROL JOB	7 - 13
TOOL LIFE CONTROL JOB	5 - 7
Troubleshooting	9 - 7, 9 - 17
Turning ON/OFF I/O Signals Forcibly	8 - 11

U

User's Message Function	7 - 12
-------------------------------	--------

V

Verifying the Part Programs	4 - 51
Version Number Function	8 - 15

W

WORKPIECE COORDINATE SYSTEM SHIFT JOB	5 - 5
Writing the Tool Life Control Data	5 - 7
Writing the Tool Offset Data	5 - 2
Writing the Workpiece Coordinate System Shift Amount	5 - 5

Y

YENET1200	9 - 17
YENET1200 command time-out	9 - 19
YENET1200 Communication Error	9 - 20
YENET1200 Compatible Inverter Control	A1 - 9, A1 - 19
YENET1200 Watchdog Error	9 - 21

YASNAC J300L

OPERATING MANUAL

TOKYO OFFICE New Pier Takesiba South Tower, 1-16-1, Kaigan, Minatoku, Tokyo 105 Japan

Phone 81-3-5402-4511 Fax 81-3-5402-4580

YASKAWA ELECTRIC AMERICA, INC.

Chicago-Corporate Headquarters 2942 MacArthur Blvd. Northbrook, IL 60062-2028, U.S.A.

Phone 1-847-291-2340 Fax 1-847-498-2430

Chicago-Technical Center 3160 MacArthur Blvd. Northbrook, IL 60062-1917, U.S.A.

Phone 1-847-291-0411 Fax 1-847-291-1018

MOTOMAN INC.

805 Liberty Lane West Carrollton, OH 45449, U.S.A.

Phone 1-513-847-6200 Fax 1-513-847-6277

YASKAWA ELÉTRICO DO BRASIL COMÉRCIO LTDA.

Avenida Brigadeiro Faria Lima 1664-5-CJ 504/511, São Paulo, Brazil

Phone 55-11-815-7723 Fax 55-11-870-3849

YASKAWA ELECTRIC EUROPE GmbH

Am Kronberger Hang 2, 65824 Schwalbach, Germany

Phone 49-6196-569-300 Fax 49-6196-888-301

Motoman Robotics AB

Box 504 S38525 Torsås, Sweden

Phone 46-486-10575 Fax 46-486-41410

Motoman Robotec GmbH

Kammerfeldstraße 1, 85391 Allershausen, Germany

Phone 49-8166-900 Fax 49-8166-9039

YASKAWA ELECTRIC UK LTD.

3 Drum Mains Park Orchardton Woods Cumbernauld, Scotland, G68 9LD U.K.

Phone 44-1236-735000 Fax 44-1236-458182

YASKAWA ELECTRIC KOREA CORPORATION

Paik Nam Bldg. 901 188-3, 1-Ga Euljiro, Joong-Gu Seoul, Korea

Phone 82-2-776-7844 Fax 82-2-753-2639

YASKAWA ELECTRIC (SINGAPORE) PTE. LTD.

151 Lorong Chuan, #04-01, New Tech Park Singapore 556741, Singapore

Phone 65-282-3003 Fax 65-289-3003

YATEC ENGINEERING CORPORATION

Shen Hsiang Tang Sung Chiang Building 10F 146 Sung Chiang Road, Taipei, Taiwan

Phone 886-2-563-0010 Fax 886-2-567-4677

BEIJING OFFICE Room No. 301 Office Building of Beijing International Club, 21 Jianguomenwa. Avenue, Beijing 100020, China

Phone 86-10-532-1850 Fax 86-10-532-1851

SHANGHAI OFFICE Room No. 8B Wan Zhong Building 1303 Yan An Road (West), Shanghai 200050, China

Phone 86-21-6212-1015 Fax 86-21-6212-1326

YASKAWA JASON (HK) COMPANY LIMITED

Rm.2916, Hong Kong Plaza, 186-191 Connaught Road West, Hong Kong

Phone 852-2858-3220 Fax 852-2547-5773

TAIPEI OFFICE Shen Hsiang Tang Sung Chiang Building 10F 146 Sung Chiang Road, Taipei, Taiwan

Phone 886-2-563-0010 Fax 886-2-567-4677



YASKAWA ELECTRIC CORPORATION

MANUAL NO. TOE-C843-13.20

© Printed in Japan January 1997 97-1 0.3